



## SPECIFICATIONS – ACCESSORIES: OPM Overheat Protection Manager

The Waterous Overheat Protection Manager (OPM) acts as a safety device by releasing hot water from the discharge area of the pump to the ground. The OPM consists of a valve that opens when the water in the pump reaches 140°F (60°C) and a warning light that is triggered by a thermal switch when the water in the pump reaches 180°F (82°C). An optional audible alarm along with the warning light act as an additional protection devices if the temperature inside the pump keeps rising although the valve is open. The OPM valve and switch are both mounted on two 1/2" tapped holes located near the center discharge area of the pump on CM and CS pump models and nearest to the main pump discharge on other Waterous pump models.



### OPM Mounted on CM/CS Pump:

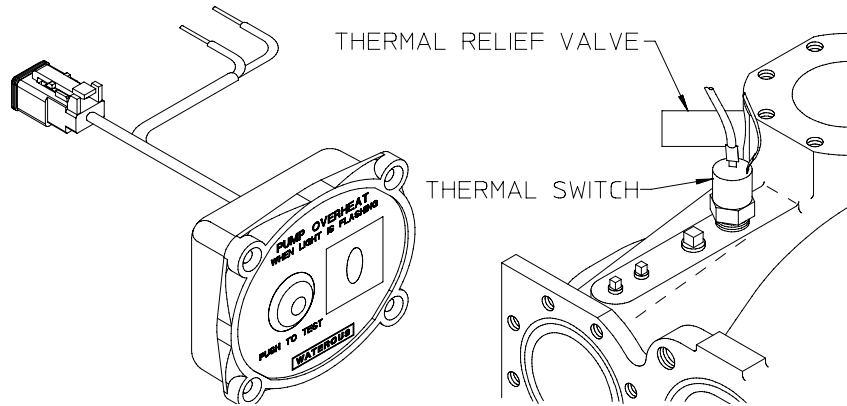

### OPM Retrofit Kit

The Waterous Overheat Protection Manager (OPM) retrofit kit (K 972-2) is available for all CM & CS series pumps built prior to 1/17/00. It acts as a safety device by releasing hot water from the discharge area of the pump to the ground or back to a water tank.

The OPM consists of a valve that opens when the water in the pump reaches 120°F (49°C) and a warning light that is triggered by a thermal switch when the water in the pump reaches 180°F (82°C).

The warning light acts as an additional protection device if the temperature inside the pump keeps rising although the valve is open. The OPM valve and switch are both mounted on a blind flange that can be installed on a vacant 2.5" pad on the discharge fitting of the pump.

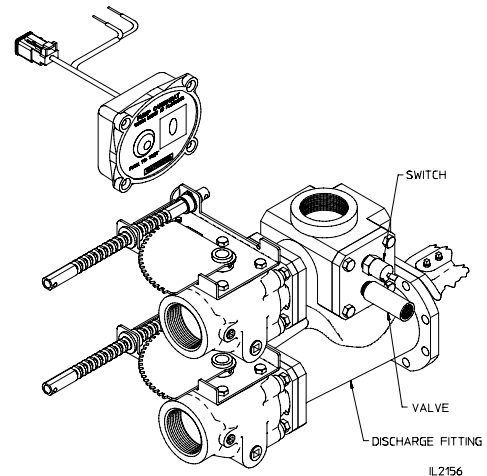

### Industry-Leading Sales and Support

When you purchase Waterous equipment, not only do you get quality products, you get quality service. Our expert service technicians are the best in the business and they are always happy to answer any service questions you might have.

**Sales/Applications Assistance**  
Phone: 651-450-5234 (Press 3)  
pumpsales@waterousco.com

**Service Assistance**  
Phone: 651-450-5200  
Fax: 800-488-1228  
service@waterousco.com

## SPECIFICATIONS – ACCESSORIES: OPM

### OPM Options: Audible Alarm

An optional audible alarm is available on the OPM which will sound when the water in the pump continues to rise.

