



SPECIFICATIONS - PTO DRIVEN: MODEL CL

Single-Stage Simplicity

The Waterous CL delivers flexible pump power with single stage simplicity at NFPA rated capacity of 500 GPM (1900 L/min) and pressure to 350 PSI (24 bar). The CL pump is compact and lightweight, with a one-piece design that makes it easy to service and maintain. The pump's intake and discharge arrangements are available in a wide variety of options to meet your specific firefighting requirements. The CL also comes with an industry exclusive five-year warranty.



Design Features:

Waterous CL pump construction features: mechanical self-adjusting seal, replaceable wear rings, a mechanically and hydraulically-balanced impeller for smooth operation and oil-lubricated, anti-friction ball bearings throughout.

Two pump transmission options are available, which provide a variety of mounting choices. The pump may be used as a power take-off driven or direct (bellhousing mounted), engine driven. Each transmission can provide for pump-and-roll performance. Intake and discharge arrangements are available

in a wide variety of types and sizes to meet your specific firefighting requirements.

Waterous pumps are built to fit individual requirements. A qualified fire apparatus application engineer can assist you in determining which combination of pump, transmission, truck chassis and engine will produce maximum performance to suit your needs.

Every pump is tested under full power before shipment to assure it meets established performance criteria.

Pump Specifications:

Pump Casing: One-piece, high-tensile ductile iron (bronze optional on CLV only).

Intake Connections: Available with 4 inch threaded (CLR) or Victaulic® (CLV).

Discharge Connections: Blank (no fitting furnished) is standard. Available with optional head with two 2-1/2 inch discharge outlets and one 2 inch NPT outlet or 3 inch NPT tapped flange.

Impellers: Bronze, fully-enclosed, double-hubbed to balance hydraulic thrust, mechanically-balanced to eliminate vibration.

Wear Rings: Replaceable wear rings to increase pump life and keep maintenance costs to a minimum.

Impeller Shaft: Stainless steel, heat treated, ground to precise size, and polished under shaft seal. Fully supported by anti-friction bearings.

Shaft Seal: Mechanical seal is standard.

Bearings: All bearings are oil or grease lubricated, anti-friction (ball-type), and located outside the pump casing to accurately align and support the impeller shaft assembly. Ball bearings are deep-groove type designed to carry both radial and axial thrust.

Intake Fittings – Choice of the Following:

Type	Model	Sizes
Threaded End Intake	CLR	4 inch NH or BSP
Victaulic® Intake	CLV	4 inch

Industry-Leading Sales and Support

When you purchase Waterous equipment, not only do you get quality products, you get quality service. Our expert service technicians are the best in the business and they are always happy to answer any service questions you might have.

Sales/Applications Assistance
 Phone: 651-450-5234 (Press 3)
 pumps@waterousco.com

Service Assistance
 Phone: 651-450-5200
 Fax: 800-488-1228
 service@waterousco.com

SPECIFICATIONS - PTO DRIVEN: MODEL CL

Pump Transmissions

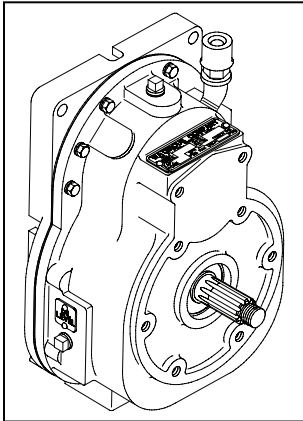

K Series

The K Series Transmission is normally used when a truck transmission mounted power take-off is selected as the pump drive.

Housings: Close-grained, gray iron

Drive Ratios: 1.62, 1.97, 2.14, 2.55, 2.79, 3.40, 4.00, 4.79

Gears: Helical, precision cut, crown shaved for proper load distribution and quiet operation.

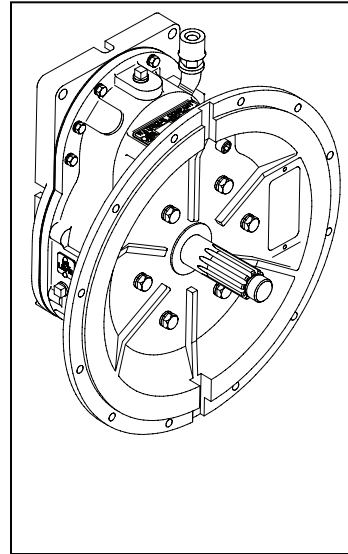

T Series

The T Series Transmission is supplied when the pump is to be mounted directly to the engine bell housing. This provides a clean, compact arrangement and allows for complete pump and roll capability.

T Transmissions are available in SAE 2, 3, 4, or 5 bell housing adapters.

Housings: Close-grained, gray iron

Drive Ratios: 1.62, 1.97, 2.14, 2.55, 2.79, 3.40, 4.00, 4.79

Gears: Helical, precision cut, crown shaved for proper load distribution and quiet operation.

Accessories & Optional Equipment

The accessories below are available for Waterous CL pumps. For detailed information about these accessories, request each specification sheet by number.

Primer

Select an electric rotary vane primer for fast, reliable priming. F-2418

Pressure Control Systems

Discharge Relief Valve

Simple ON-OFF control permits placing the system in or out of operation in seconds. See Relief Valve, F-897.

Intake Relief Valves

The Waterous intake relief valve is designed to dump excess pressure from the inlet side of the pump. See Intake Relief Valves, F-2192.

Corrosion Protection

Waterous offers replaceable zinc intake screens and anodes to provide corrosion protection. These items are designed to sacrifice the zinc element to galvanic corrosion. Without this protection, galvanic corrosion may damage the iron pump body and fittings.

Overheat Protection Manager

The OPM consists of an illuminated warning light on the operator's panel whenever the pump approaches an overheat condition. F-2422

Drain Valves

Drains all points of the pump simultaneously with the operation of a single control. F-1158

Discharge Valves

The following Waterous ball-type discharge valves are available: 2-1/2 inch, 3-1/2 inch, rack and sector push-pull, worm gear and electric. Chrome-plated brass ball and hydraulically-balanced seal assembly standard. See Discharge Valves, F-1161.

Tachometer

Tachometer drive available; operates at 1/2 input shaft speed.

Approximate Dimensions and Weights

(Width & Height dimensions refer to picture shown on front page - less fittings and valves)

Pump/Transmission Model	Intake	Length in/cm	Width in/cm	Height in/cm
CLRK	4 in. NH	18-1/8 (46.0)	15-1/8 (38.4)	21-1/4 (54.0)
	4 in. BSP	18-3/4 (47.6)	15-1/8 (38.4)	21-1/4 (54.0)
CLRT	4 in. NH	18-1/4 (46.4)	17-3/4 (45.1)	24-3/8 (61.9)
	4 in. BSP	18-7/8 (47.9)	17-3/4 (45.1)	24-3/8 (61.9)
CLVK	4 in. Victaulic®	18-3/4 (47.6)	15-1/8 (38.4)	21-1/4 (54.0)
CLVT	4 in. Victaulic®	18-7/8 (47.9)	17-3/4 (45.1)	24-3/8 (61.9)