



SPECIFICATIONS - PTO DRIVEN: MODEL CP-2 Pumping On The Go

Adaptable to pump-and-roll operation, the CP-2 will supply two or more lines with adequate pressure for use with either straight stream or fog nozzles. The CP-2 can also be used in relay with portable pumps to boost pressure to effective levels when pumping from otherwise inaccessible water sources or to pump de-icing solution used at airports across the world. The CP-2 is normally driven by a transmission side-mounted PTO or, as an option, can be bell-house mounted. The CP-2 also comes with an industry exclusive five-year warranty.



Design Features:

The CP-2 is normally driven by a transmission side mounted power take-off or other suitable drive. It has an integral speed increasing transmission custom fitted with the proper gear ratio to provide required impeller speeds at available input speeds, whether pumping from tank, draft, or in relay operation.

Construction features of the CP-2 include helical gears; replaceable wear rings, balanced impeller, and anti-friction ball

bearings running in oil to support the impeller shaft and drive shaft.

Because the Waterous CP-2 has been designed with versatility in mind, and each unit is custom built to fit your particular requirements, it is best to consult your builder of Waterous equipped apparatus to determine the top performance of this combination with the chassis and engine/transmission of your choice.

Pump Specifications:

Casing:

High-tensile, nickel-bearing gray iron (bronze optional).

Wear Rings:

Bronze

Impeller:

Bronze, double-hubbed, hydraulically and mechanically balanced.

Seal Type:

Mechanical seal is standard.

Intake:

3 inch (7.6 cm) NPT, or 3 inch BSP*

Discharge:

2 inch (5 cm) NPT, or 2 inch BSP*

*BSP (British Pipe) threads are available as straight or tapered. Straight threads are per BS2779 for fittings where pressure-tight joints are not made on the threads. Tapered threads are per BS21 for fittings where pressure-tight joints are made on the threads.

Discharge Positions:

Available in either rotation with four discharge positions; gear case can be mounted horizontally, vertically, or inverted.

Bearings:

Completely ball bearing equipped, oil-splash lubricated.

Installation:

Universal joints, shaft, piping, and controls are furnished by fire apparatus builder.

Performance:

The CP-2 is capable of supplying volumes of 300 GPM (1135 L/min) @ 150 psi (10.3 bar) or pressures of 400 psi (28 bar) @ 60 GPM (227 L/min).

When installed in vehicle, complete with proper intake piping, CP-2 meets NFPA 1901 for a 250 GPM rating.

Industry-Leading Sales and Support

When you purchase Waterous equipment, not only do you get quality products, you get quality service. Our expert service technicians are the best in the business and they are always happy to answer any service questions you might have.

Sales/Applications Assistance

Phone: 651-450-5234 (Press 3)
pumps@waterousco.com

Service Assistance

Phone: 651-450-5200
Fax: 800-488-1228
service@waterousco.com

SPECIFICATIONS - PTO DRIVEN: MODEL CP-2

Pump Transmissions

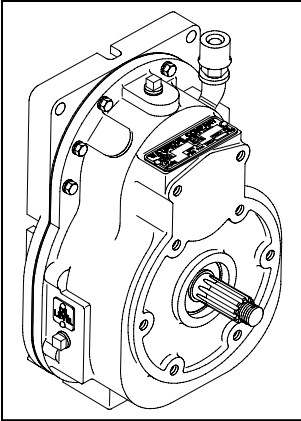

K Series

The K Series Transmission is normally used when a truck transmission mounted power take-off is selected as the pump drive.

Housings: Close-grained, gray iron

Drive Ratios: 1.62, 1.97, 2.14, 2.55, 2.79, 3.40, 4.00, 4.79

Gears: Helical, precision cut, crown shaved for proper load distribution and quiet operation.

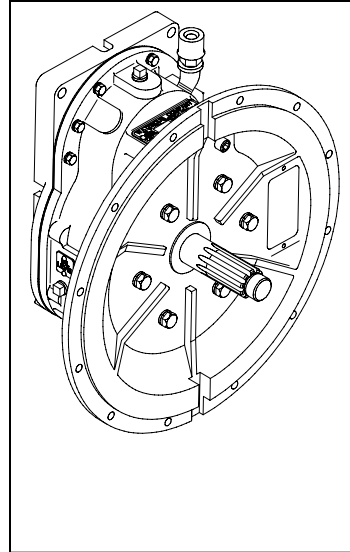

T Series

The T Series Transmission is supplied when the pump is to be mounted directly to the engine bell housing. This provides a clean, compact arrangement and allows for complete pump and roll capability.

T Transmissions are available in SAE 2, 3, 4, or 5 bell housing adapters.

Housings: Close-grained, gray iron

Drive Ratios: 1.62, 1.97, 2.14, 2.55, 2.79, 3.40, 4.00, 4.79

Gears: Helical, precision cut, crown shaved for proper load distribution and quiet operation.

Accessories & Optional Equipment

The accessories below are available for Waterous CP-2 pumps. For detailed information about these accessories, request each specification sheet by number.

Primer

Select an electric rotary vane primer for fast, reliable priming. F-2418

Pressure Control Systems

Discharge Relief Valve

Simple ON-OFF control permits placing the system in or out of operation in seconds. See Relief Valve, F-897.

Intake Relief Valves

The Waterous intake relief valve is designed to dump excess pressure from the inlet side of the pump. See Intake Relief Valves, F-2192.

Corrosion Protection

Waterous offers replaceable zinc intake screens and anodes to provide corrosion protection. These items are designed to sacrifice the zinc element to galvanic corrosion. Without this protection, galvanic corrosion may damage the iron pump body and fittings.

Overheat Protection Manager

The OPM consists of an illuminated warning light on the operator's panel whenever the pump approaches an overheat condition. F-2422

Drain Valves

Drains all points of the pump simultaneously with the operation of a single control. F-1158

Discharge Valves

The following Waterous ball-type discharge valves are available: 2-1/2 inch, 3-1/2 inch, rack and sector push-pull, worm gear and electric. Chrome-plated brass ball and hydraulically-balanced seal assembly standard. See Discharge Valves, F-1161.

Tachometer

Tachometer drive available; operates at 1/2 input shaft speed.

Dimensions and Weights

Measurement	Length	Width	Height	*Weight
US ¹	16.25	10	14.8	140
Metric ²	32.1	25.4	37.6	63.5

* Includes oil

¹ US measurements in inches and pounds

² Metric measurements in centimeters and kilograms

Performance Ratings

Capacity - GPM / L/min	Pressure - PSI / Bar
300 (1135)	150 (10.3)
250 (946)	150 (10.3)
150 (568)	225 (16)
100 (378)	250 (17)
60 (227)	400 (27)

Performance ratings based on pumping from draft with 3" (7.6 cm) or 3-1/2" (8.9 cm) piping. Maximum pressure which can be developed at any particular capacity will be determined by the pump transmission ratios, engine and/or PTO rating.