

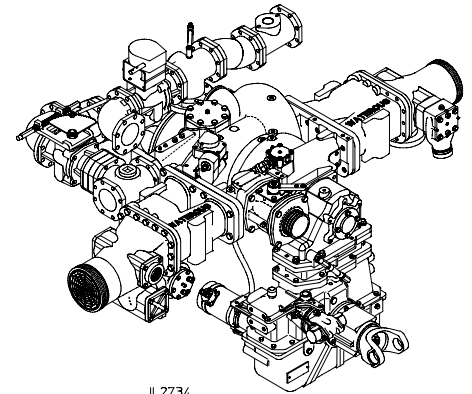

SPECIFICATIONS - VEHICLE MOUNTED: HIGH-RISE PUMP CM/CGV SERIES CMU/CGV SERIES

The results of Waterous' advanced engineering capabilities are quality products that are thoroughly tested to meet NFPA standards and special contract provisions, while exceeding the demands of firefighters in the field. Versatility, combined with simple operation and exclusive design features are what separate the High-Rise Series Fire Pumps from its competitors. The High Rise pump can operate as a CM/CMU pump only or as a CGV high pressure pump in series with the CM/CMU pump with performance ratings from 500 up to 2250 GPM (1900 up to 4750 L/min) operating as a stand alone CM/CMU pump and pressures up to 700 psi (48 bar) with the CGV high pressure stage. The High-Rise Pump is also backed by a standard five-year warranty. An optional Total Protection Package (TPP-5) is available.



IL2734

Design Features:

The High Rise pump has a CGV high pressure stage connected to the CM/CMU body end opposite the "C10" series transmission. The two pumps share a common impeller shaft which is spline connected to the "C10" transmission. A grease lubricated bearing in an adapter housing between the two pumps resists impeller shaft axial loads and (with the "C10" transmission bearings) radial loads. The suction of the CGV pump is connected through an isolation valve to the left hand side outlet of the CM/CMU pump discharge manifold.

The CM/CMU pump is sealed by the normal packing stuffing boxes.

The CGV pump is sealed with a double mechanical seal. The double mechanical seal chamber provides a water pocket to cool and lubricate the seal surfaces when only the CM/CMU pump is being used.

The double mechanical seal chamber is supplied water from the CM/CMU pump first stage through a check valve when only the CM/CMU pump is being used. Some of this water goes back to the CM/CMU pump suction manifold through an orifice tube. The remainder of this water goes through orifice holes in the mechanical seal chamber into the CGV pump where it flushes the wear rings before draining out the bottom of the CGV pump.

The double mechanical seal chamber is supplied water through orifice holes in the mechanical seal chamber when the

combined High Rise pump is in operation. This water flows to the CM/CMU pump suction manifold through the orifice tube. The vent and drain valves of the CGV pump are lever connected to the isolation valve (in the passage from the discharge to CGV suction). The vent and drain valves are open when the isolation valve is closed (CM/CMU pump operation) and closed when the isolation valve is open (CGV high pressure stage).

A control panel light turns on when the isolation valve is in an intermediate position (not full open or full closed). The light is actuated when the valve sector gear does not engage one of two normally closed switches mounted on the valve bracket. Two rotary actuated, high pressure Waterous 3-1/2" ball valves are installed in the CGV discharge.

Two transmission oil coolers are installed in the rear upper taps of the intake fittings. The coolers consist of a copper tube coiled inside of a pipe. One end of the pipe is blocked off and contains the connections of the copper tube to the transmission hoses. The other end of the pipe is screwed into the intake fitting.

Water circulating on the outside of the coiled tube cools oil flowing on the inside of the coiled tube. Oil circulates from the discharge of the transmission oil pump, through each coiled tube cooler in series, then back to the transmission.

Industry-Leading Sales and Support

When you purchase Waterous equipment, not only do you get quality products, you get quality service. Our expert service technicians are the best in the business and they are always happy to answer any service questions you might have.

Sales/Applications Assistance
Phone: 651-450-5234 (Press 3)
pumps@waterousco.com

Service Assistance
Phone: 651-450-5200
Fax: 800-488-1228
service@waterousco.com

SPECIFICATIONS - VEHICLE MOUNTED: HIGH-RISE PUMP

CM/CMU Pump Specifications

Casing:

Two-piece, horizontally-split, high-tensile, close grained gray iron or bronze (optional). All passageways are carefully matched to assure the very best hydraulic flow characteristics.

Wear Rings:

Bronze, reverse-flow, labyrinth-type replaceable wear rings increase pump life and keep maintenance costs to a minimum.

Impellers:

Matched bronze impellers, balanced both mechanically and hydraulically for vibration-free operation. Flame-plated impeller hubs (optional on CM, standard on CMU pumps) assure longer life despite the presence of abrasives in the water supply.

Impeller Shaft:

Heat-treated stainless steel is ground at all critical areas, polished under packing. An exclusive two-piece impeller shaft allows separation of the transmission from the pump without disassembling either component. This simplifies repair procedures, resulting in less down time.

Bearings:

Three deep-groove, anti-friction ball bearings, located outside the pumping chamber, give support and proper alignment to the impeller shaft assembly. Bearings are oil or grease lubricated, completely separated from the water being pumped, and protected by seal housings, flinger rings and oil seals.

Shaft Seal:

Seal housings on packed pumps are equipped with braided flexible graphite (BFG) rings held in place by a split bronze gland which is fully removable and adjustable. BFG packing improves heat dissipation, reduces maintenance and minimizes shaft wear. Self-adjusting, spring-loaded mechanical seals are available which eliminate leakage and routine maintenance.

Flinger Rings:

Located on the impeller shaft between seal housings and bearing housings, flinger rings provide added protection and keep water and foreign matter out of the bearings.

Oil Seals:

Standard lip type for lubrication and additional bearing protection from dirt and water.

Transfer Valve:

Ball type bronze valve, in removable bronze housings with large waterways for smooth flow. Manual operation is standard, electric operation is optional. The Waterous transfer valve provides smooth transfer to either PRESSURE or VOLUME without sticking. Pump

CGV Pump Specifications

Casing:

Two-piece, vertically-split, high-tensile, close-grained gray iron.

Impeller:

Bronze impeller specifically designed for the fire service, double-hubbed to eliminate axial thrust, and accurately balanced for vibration-free running. Impellers with flame-plated hubs for extreme wear resistance are optional.

Wear Rings:

Replaceable bronze wear rings to increase pump life and keep maintenance costs at a minimum.

Impeller Shaft:

Stainless steel, heat treated, precisely ground to size, and polished under shaft seal. Supported by oil-lubricated ball bearings.

Bearings:

All bearings are oil or grease lubricated, ball-type, located outside the pump casting to accurately align and support the impeller shaft assembly. Ball bearings are deep-groove type designed to carry both radial and axial thrust.

Shaft Seal:

Double-mechanical seal. The double-mechanical seal chamber provides a water pocket to cool and lubricate the seal surfaces when only the CM pump is being used.

C20 Transmission Specifications

C20 Series

Housings: High-strength aluminum, three-piece, horizontally-split.

Drive Ratios: 2.27, 2.46 and 2.73.

Shafts: Drive line shafts made from alloy steel forgings, hardened and ground to size, 2.35 inch 46-tooth involute spline.

Drive and Driven Sprockets

Made of steel. All sprockets are hardened and have ground bores.

Drive Chain

Morse HV[®] high-strength involute form chain.

Bearings

Deep-groove, anti-friction ball bearings give support and proper alignment to the impeller shaft assembly. Bearings are oil-splash lubricated, completely separated from the water being pumped, and protected by a V-ring and oil seals.

Lubrication System

An internal lubrication system delivers lubricant directly to the drive chain. This unique design eliminates the need for an external lubrication pump and auxiliary cooling.

Shift Mechanism

Constant-mesh, two-position sliding collar that engages all teeth simultaneously. In-cab controlled pneumatic shift or optional manual shift. A patented internal locking mechanism provides a positive lock in PUMP or ROAD position.

Accessories & Optional Equipment

The accessories below are available for Waterous High-Rise pumps. For detailed information about these accessories, request each specification sheet by number.

Pneumatic Shift

Air power allows the operator to shift to ROAD or PUMP position by actuating a simple valve. Illuminated LED's signal completion of shift from ROAD to PUMP. See Power Shift, F-1154.

Primer

Select an electric rotary vane primer for fast, reliable priming. F-2418 Pressure Control Systems

Discharge Relief Valve

Simple ON-OFF control permits placing the system in or out of operation in seconds. See Relief Valve, F-897.

Intake Relief Valves

The Waterous intake relief valve is designed to dump excess pressure from the inlet side of the pump. See Intake Relief Valves, F-2192.

Corrosion Protection

Waterous offers replaceable zinc intake screens and anodes to provide corrosion protection. These items are designed to sacrifice the zinc element to galvanic corrosion. Without this protection, galvanic corrosion may damage the iron pump body and fittings.

Overheat Protection Manager

The OPM consists of an illuminated warning light on the operator's panel whenever the pump approaches an overheat condition. F-2422

Drain Valves

Drains all points of the pump simultaneously with the operation of a single control. F-1158

Tank to Pump Valve

The tank to pump valve is a full-flow 3-1/2 in. diameter ball valve which is attached directly to the pump. The valve is operated by either a 90° spring detent remote control handle or an electric rotary actuator. F-2536

Discharge Valves

The following Waterous ball-type discharge valves are available: 2-1/2 inch, 3-1/2 inch, rack and sector push-pull, worm gear and electric. Chrome-plated brass ball and hydraulically-balanced seal assembly standard. See Discharge Valves, F-1161.

Electric Transfer Valve

Provides smooth transfer to either PRESSURE or VOLUME. See Electric Transfer Valve, F-1155.

Monarch Intake Valve

An extra short intake fitting, intake butterfly valve and intake nipple with integral relief valve mounting pad, all designed to fit behind the pump panel. F-2394.

