



SPECIFICATIONS - ENDURANCE™: MODEL S101
You Don't Need "Muscles" to be a Strong Performer

The S101 pump with the new "Ram Horn" intake provides up to 2000 GPM @ 150 psi. With a smaller footprint than other larger midship-mounted fire pumps, the S101 will save compartment space for those important tools needed when fighting a fire. Other advantages of the S101 are - easier installation for OEM's (intake piping and mounting), draft from either side of the truck and weight savings by utilizing the next generation C20 transmission (lighter on weight, uses less oil). Make the S101 even better by integrating a Waterous CAFSystem™. The S101 is also backed by a standard five-year warranty. An optional Total Protection Package (TPP-5) is available.



Design Features:

The S101 is a single stage that is mated to a C20 aluminum transmission.

Construction features of the S101 include a ductile iron case, replaceable wear rings, bronze balanced, flame-plated impeller and a mechanical seal.

Because the Waterous S101 has been designed with versatility in mind, and each unit is custom built to fit your particular requirements, it is best to consult your builder of Waterous equipped apparatus to determine the top performance of this combination with the chassis and engine/transmission of your choice.

Pump Specifications:

Pump Body:

Cast in ductile iron. Double stripping edge volute minimizes radial forces at all flow rates.

Intake:

Dual Intake Wye (Ram Horn)

Discharge:

5 inch ANSI flange or an optional 21st Century Manifold (4 in. end flanged manifold with (8) 2-1/2 in. side pads) or an optional 5 in. ANSI to 4 in. ANSI adapter.

Impeller:

Bronze impeller, balanced mechanically and hydraulically for vibration-free operation and flame-plated to assure longer life despite the presence of abrasives in the water supply.

Impeller Shaft and Seal:

Stainless steel shaft and impeller nut with spring-loaded mechanical shaft seal. Self-adjusting mechanical seal eliminates leakage and routine maintenance.

Wear Rings:

Bronze labyrinth-type (reverse-flow) replaceable wear rings increase pump life and keep maintenance costs to a minimum.

V-ring:

Located on the impeller shaft between mechanical seal and transmission oil seal, the V-ring provides added protection by keeping water and foreign matter out of the bearings.

Oil Seals:

Single lip, spring-loaded design for lubrication seal and additional bearing protection from dirt and water.

Performance:

GPM (L/min)	PSI (bar)	Impeller RPM	HP (kW)
1250 (4750)	150 (10.3)	3315	162 (121)
1500 (5700)	150 (10.3)	3430	187 (139)
1750 (6625)	150 (10.3)	3565	216 (161)
2000 (7570)	150 (10.3)	3700	251 (187)

Industry-Leading Sales and Support

When you purchase Waterous equipment, not only do you get quality products, you get quality service. Our expert service technicians are the best in the business and they are always happy to answer any service questions you might have.

Sales/Applications Assistance

Phone: 651-450-5234 (Press 3)
 pumpsales@waterousco.com

Service Assistance

Phone: 651-450-5200
 Fax: 800-488-1228
 service@waterousco.com

SPECIFICATIONS - ENDURANCE™: MODEL S101

Pump Transmission

S101C20

Housing: High-strength aluminum

Drive Ratios: 1.27, 1.41, 1.48, 1.58, 1.69, 1.79, 1.88, 1.97, 2.03, 2.27, 2.46 and 2.73

Shafts: Drive line shafts made from alloy steel forgings, hardened and ground to size.

Drive and Driven Sprockets

Made of steel. All sprockets are hardened, and have ground bores.

Drive Chain

Morse HV^{®**} high-strength involute form chain.

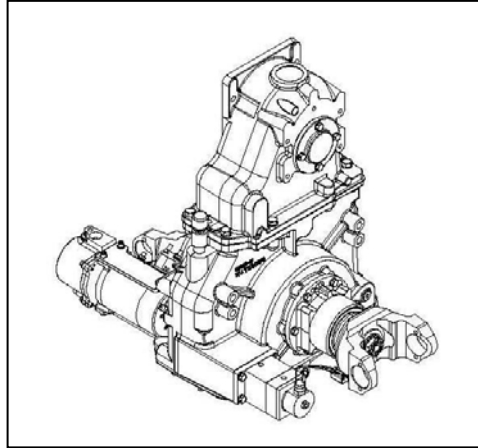

Bearings

Deep-groove, anti-friction ball bearings give support and proper alignment to the impeller shaft assembly. Bearings are oil-splash lubricated, completely separated from the water being pumped, and protected by a V-ring and oil seals.

Passive Lubrication System

C20 uses a passive lubrication system that eliminates the need for a separate oil pump.

Shift Mechanism

Constant-mesh, two-position sliding collar that engages all teeth simultaneously. In-cab controlled pneumatic shift or an optional electric shift. A patented internal locking mechanism provides a positive lock in PUMP or ROAD position.

Accessories & Optional Equipment

The accessories below are available for Waterous S100 pumps. For detailed information about these accessories, request each specification sheet by number.

Power Shift

Pneumatic shift is standard. Pneumatic shift power allows the operator to shift to ROAD or PUMP position by actuating a simple switch or valve. Electric indicating lights signal completion of shift from ROAD to PUMP. See Power Shift, F-1154.

Primer

Select an electric rotary vane priming system. All can be factory installed to your C10 Series pump transmission. See Priming Systems, F-2418

Electronic Tachometer Sensor

Monitors driveline rotational speed.

Pressure Control Systems

Intake Relief Valves - Separately Mounted

The Waterous intake relief valve is designed to dump excess pressure from the inlet side of the pump. See Intake Relief Valves, F-2192.

21st Century Manifold

The 21st Century Manifold is designed to be mounted on the S100 discharge flange. It can be orientated for top or side-mount control panels. Flange arrangements and spacing allows for organized horizontal layout plumbing of all discharges and eases the layout of the panel by the apparatus builder. See 21st Century Manifold, F-2478.

Corrosion Protection

Waterous offers replaceable zinc intake screens and anodes to provide corrosion protection. These items are designed to sacrifice the zinc element to galvanic corrosion. Without this protection, galvanic corrosion may damage the iron pump body and fittings.

Overheat Protection Manager

The OPM consists of an illuminated warning light on the operator's panel whenever the pump approaches an overheat condition. See OPM, F-2422

Drain Valves

Drains all points of the pump simultaneously with the operation of a single control. See Drain Valves, F-1158

Total Protection Package (TPP-5)

The Total Protection Package is a comprehensive warranty that increases your standard warranty to include labor expenses to dismantle, remove and reinstall covered products or parts, F-2626.