

WATEROUS

Form Number: F-2856

Issue Date: Sept 26, 2018
Revision Date: Sept 17, 2021

FLOTO-PUMP®

Operation and Maintenance

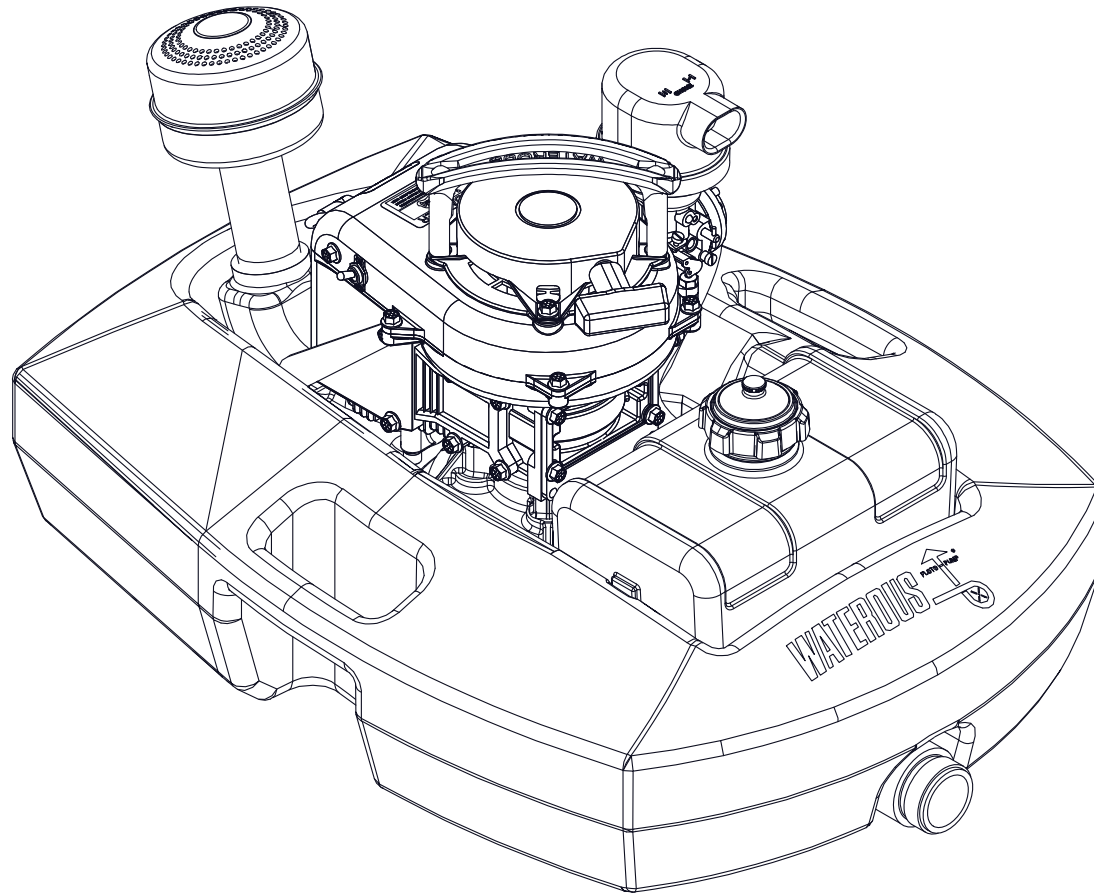

Waterous Company • 125 Hardman Avenue South • South Saint Paul, MN 55075 • (651) 450-5000

www.waterousco.com

Table of Contents

Safety	4	Maintenance	21
Safety Precautions	4	Adjusting the Carburetor	21
Safety and Instructional Decals	6	Adjusting the Throttle Float	22
Carbon Monoxide Warning	6	Preparing the FLOTO-PUMP for Short Term Storage	23
Hot Surface Warning	6	Preparing the FLOTO-PUMP for Long Term Storage	24
Sound Level Warning	6		
Introduction	7	Service Parts	26
Using this Document	7	Engine, Replacement Assemblies, and Repair Kits	26
Viewing the Document Electronically	7	Additional Engine Specifications	27
Printing the Document	7	Float and Fuel System Components—Standard FLOTO-PUMP	28
Locating the Serial Number	7	Exhaust and Air System Components—Standard FLOTO-PUMP	30
		Pump and Impeller Components—Standard FLOTO-PUMP	32
		Float and Fuel System Components—High Pressure FLOTO-PUMP	34
		Exhaust and Air System Components—High Pressure FLOTO-PUMP	36
		Pump and Impeller Components—High Pressure FLOTO-PUMP	38
Product Overview	8	Troubleshooting	40
System Overview	8	Troubleshooting	40
Top Side Components	10		
Engine Components	12		
Bottom Side Components	14		
Operation	16		
Initial Operation	16		
Preparing for the Operation	16		
Operating Tips	16		
Fueling the Pump	17		
Connecting a Hose to the Pump	18		
Starting and Stopping the Pump	19		
Operating the Pump	20		

Safety Precautions

- Read and understand all the associated documentation before you operate the equipment.
- Read and understand all the notices and safety precautions.
- Be aware that these instructions are only guidelines and are not meant to be definitive. Contact Waterous when you have questions about installing, operating, or maintaining the equipment.
- Do not install the equipment if you are not familiar with the tools and skills needed to safely perform the required procedures—proper installation is the responsibility of the purchaser.
- Do not operate the equipment when safety guards are removed.
- Do not modify the equipment.
- Regularly check for leaks, worn, or deteriorated parts.



WARNING

Hot Surface

- Hot surface can burn you.
- Do not touch the surface during operation—allow it to cool after operating.

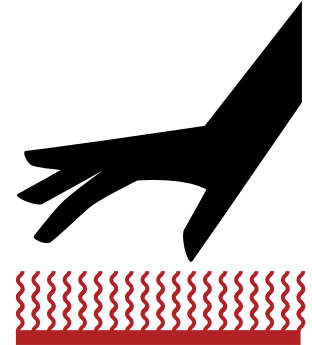

WARNING

Moving Parts

- Rotating parts can cause severe injury or death.
- Keep clear of moving parts when the equipment is operating.

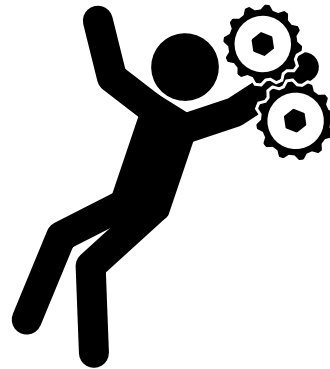

WARNING

Hot Liquid

- Hot liquid can scald you.
- Do not operate if the water temperature exceeds 160°F (71°C).

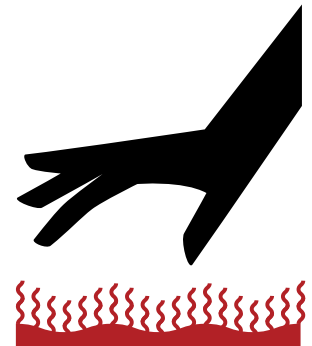

Safety Precautions

WARNING

Carbon Monoxide

- Carbon monoxide gas will kill you.
- Never operate the engine in an enclosed space.

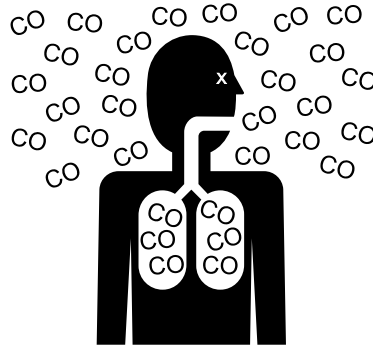

NOTICE

Modification

- Modifying the equipment can damage components and void your warranty.
- Do not modify the system or any of its components.

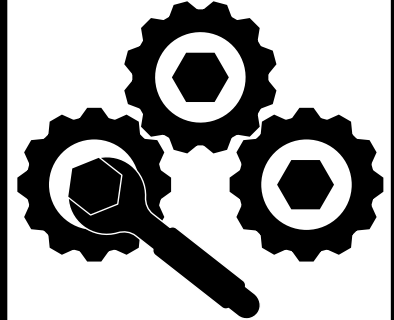

NOTICE

Before Operation

- Read and understand all the instructions provided.
- Check all fluid levels and replenish if necessary.
- Remove the all shipping plugs and install the operation plugs or caps.



CAUTION

Hearing Loss

- High sound levels will cause hearing loss.
- Wear hearing protection when operating this equipment.



Safety and Instructional Decals

Locate and review the condition of the safety decals. Replace any decals that are damaged or missing.

Carbon Monoxide Warning

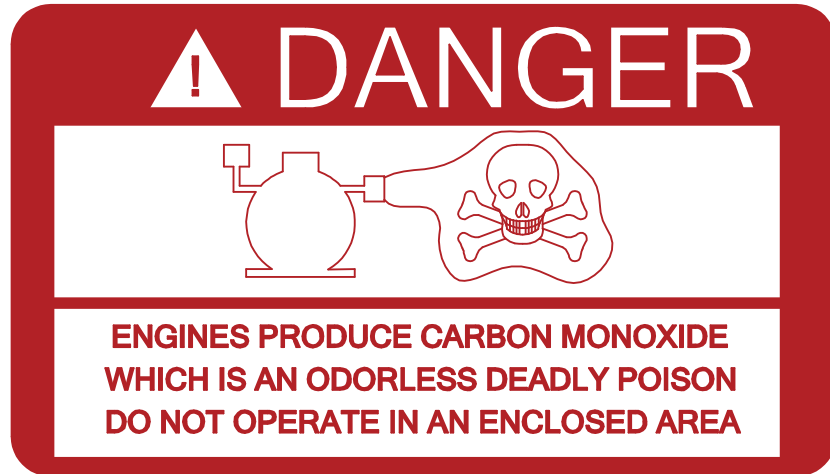

Sound Level Warning



Hot Surface Warning



Use this document to install and operate your Waterous equipment. Understand the following conditions before continuing with the document:

- The instructions may refer to options or equipment that you may not have purchased with your system.
- The illustrations in this document are intended to convey concepts. Do not use the illustrations to determine physical attributes, placement, or proportion.
- The equipment described in this document is intended to be operated by a person or persons with the basic knowledge of operating similar equipment.

This document is divided into the following sections:

SAFETY

This section describes general precautions and alert symbols that are in this document.

INTRODUCTION

This section is an overview of the document.

PRODUCT OVERVIEW

This section describes the components that make-up the system.

OPERATION

This section describes the equipment operation.

MAINTENANCE

This section describes the equipment maintenance.

SERVICE PARTS

This section describes the equipment service parts.

TROUBLESHOOTING

This section describes troubleshoot the equipment.

WARRANTY

This section describes the equipment warranty.

Using this Document

Use the guidelines below when viewing this document.

Viewing the Document Electronically

- View this document in landscape orientation.
- Use the table of contents to navigate directly to that section.
- Text **with this appearance** is linked to a reference.

Printing the Document

- The document is viewed the best when printed in color.
- The *print on both sides* and *flip on long edge* features can provide the best results.
- Use a 3-ring binder to store the document.

Locating the Serial Number

Locate and record the model and serial number of the equipment in your application. Have this information available when you call Waterous.

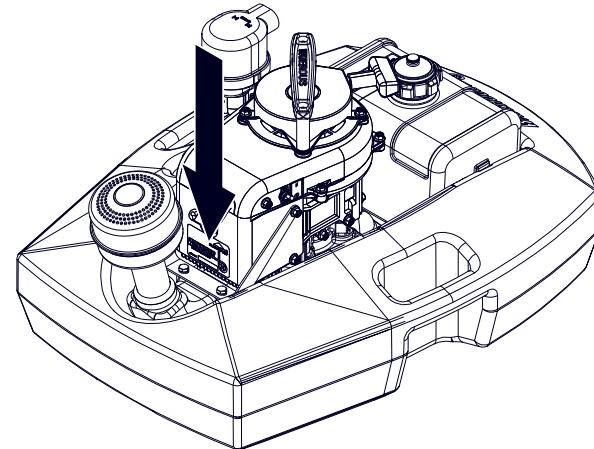

Model number-

Date-

System Overview

The FLOTO-PUMP® system allows you to pump from open bodies of water like ponds, lakes, or swimming pools. The system is available with a variety of hose connections. The pump is also available as a normal and high pressure system.

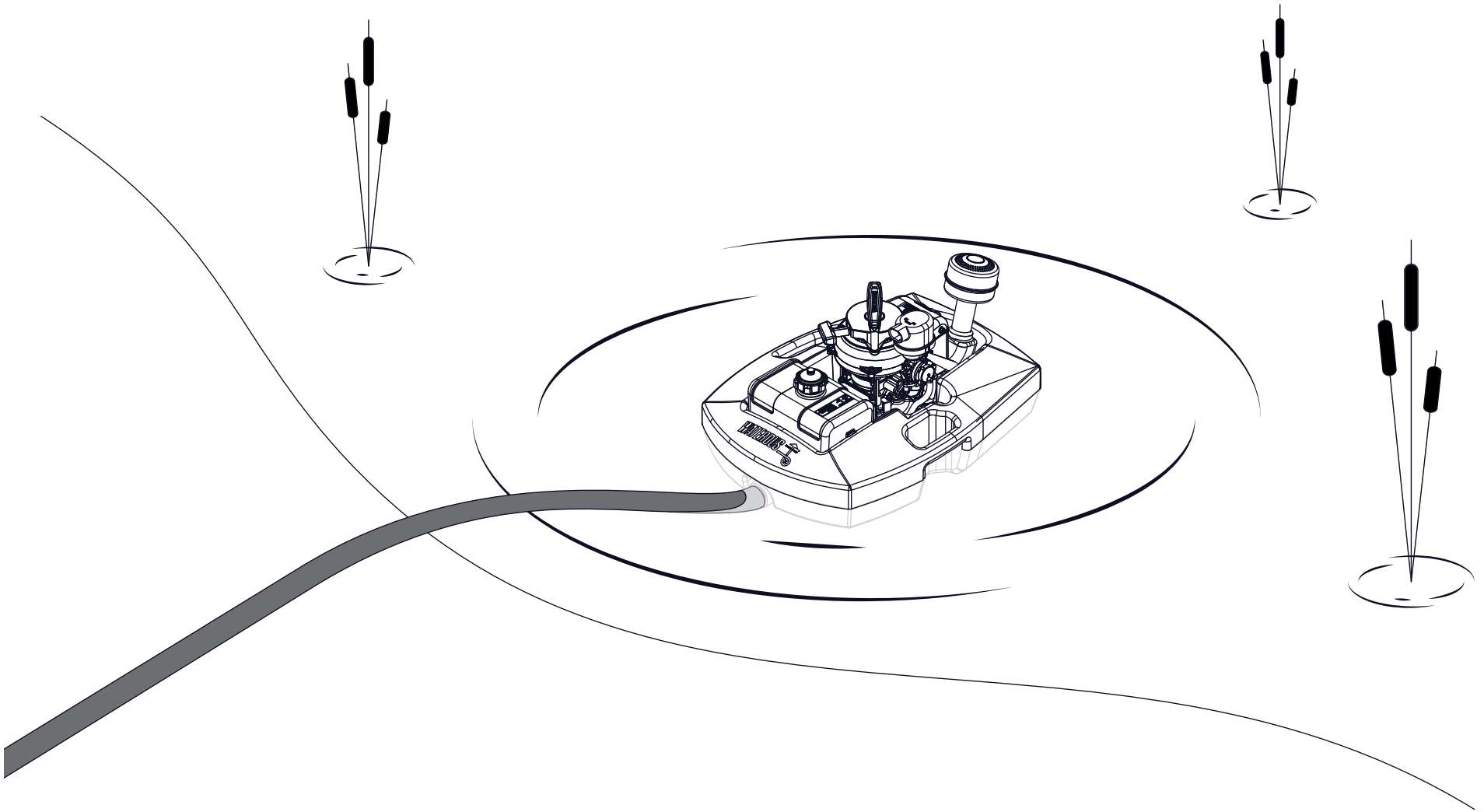

Top Side Components

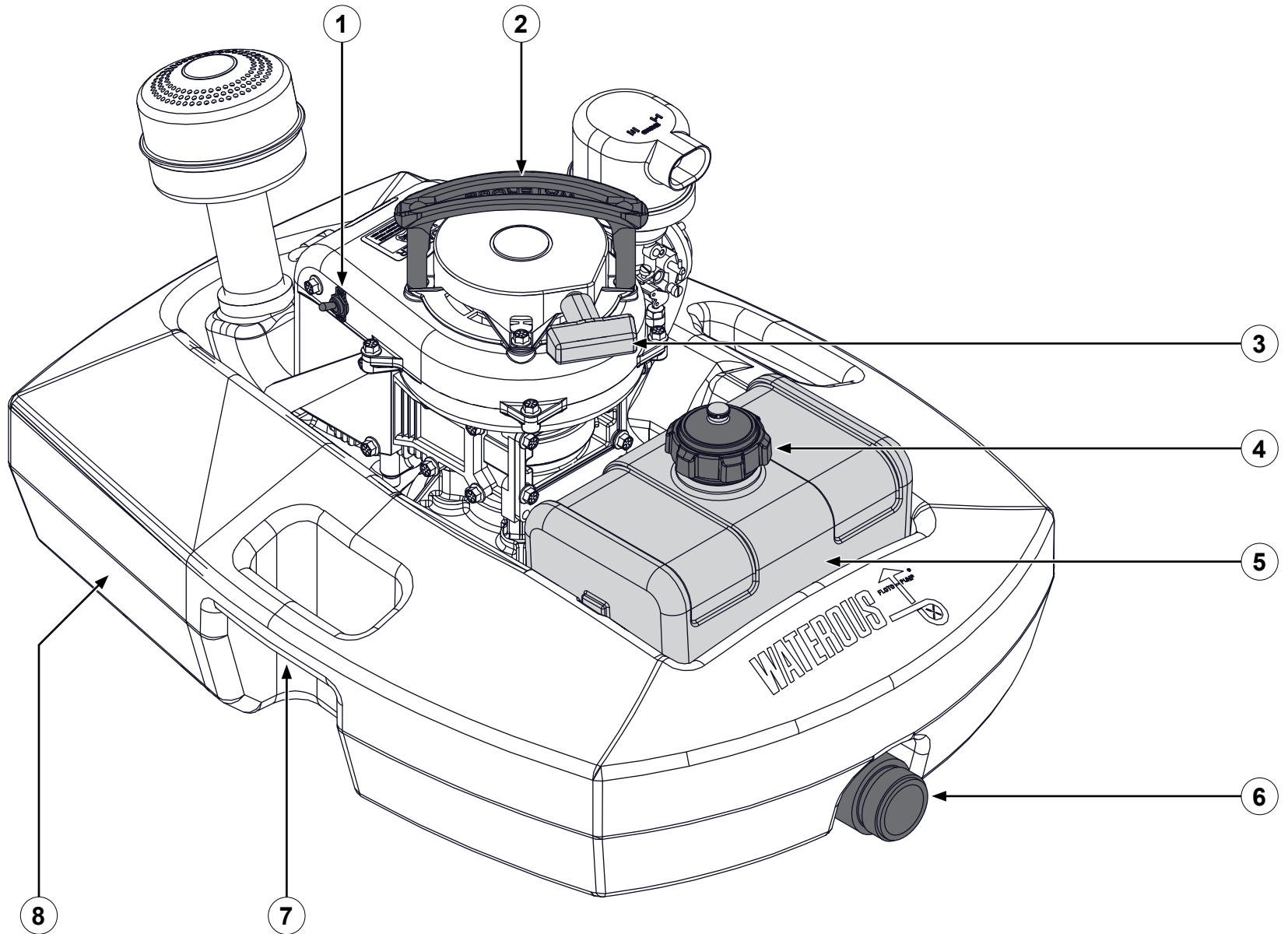

Top Side Components

Feature	Description
1 On/off switch	This enables the pump to start and stops the pump when operating.
2 Handle	This is used to transport the pump.
3 Pull handle	This starts the engine.
4 Fuel cap with vent	This seals the fuel tank and has a vent that is closed for transportation and opened for operation.
5 Fuel tank	This contains the fuel.
6 Pump discharge	This is where the hose connects to the pump.
7 Handle	This is used to transport the pump.
8 Float	This provides buoyancy for the pump.

Engine Components

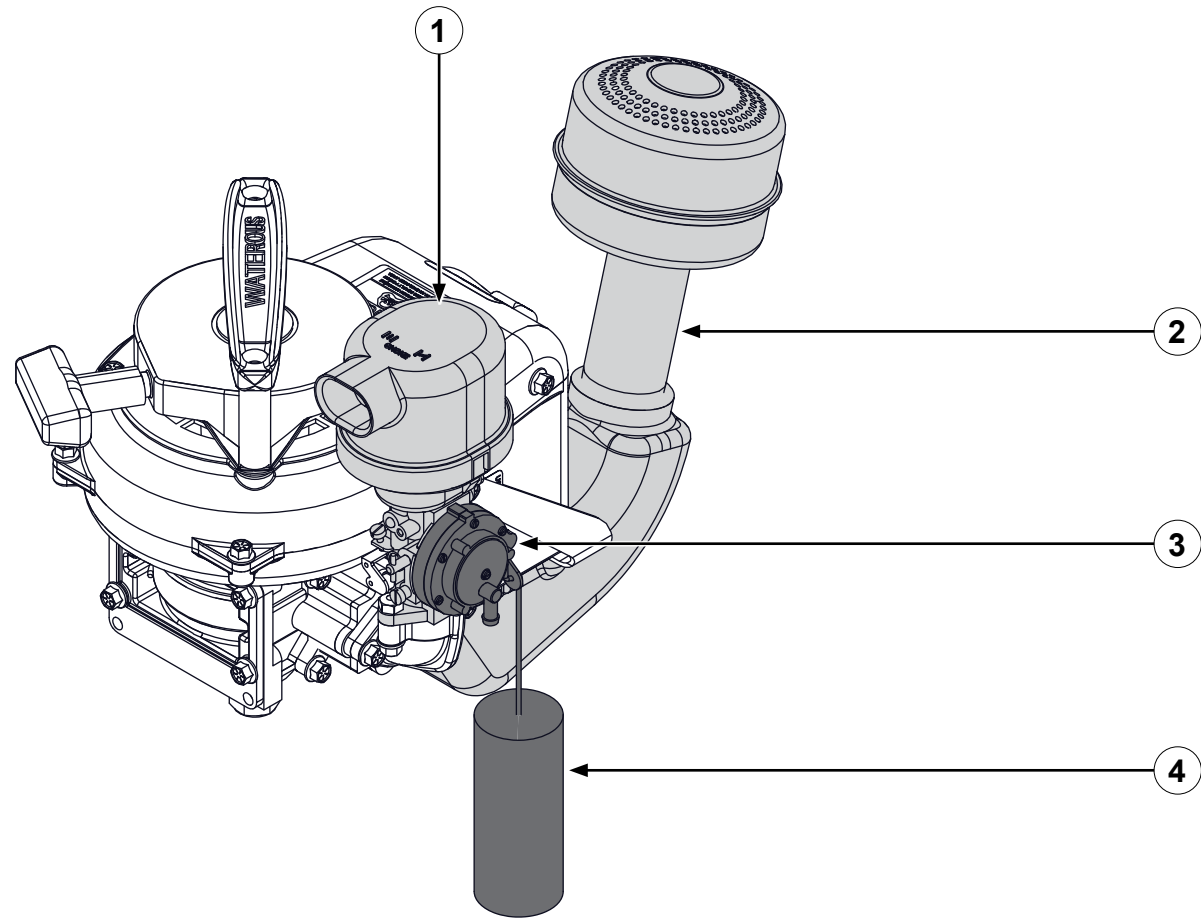

Engine Components

	Feature	Description
1	Air intake	This manages the air intake.
2	Muffler	This manages the engine sound levels.
3	Throttle assemble	This manages the fuel delivered to the engine.
4	Throttle float	This manages the fuel supply to the engine.

Bottom Side Components

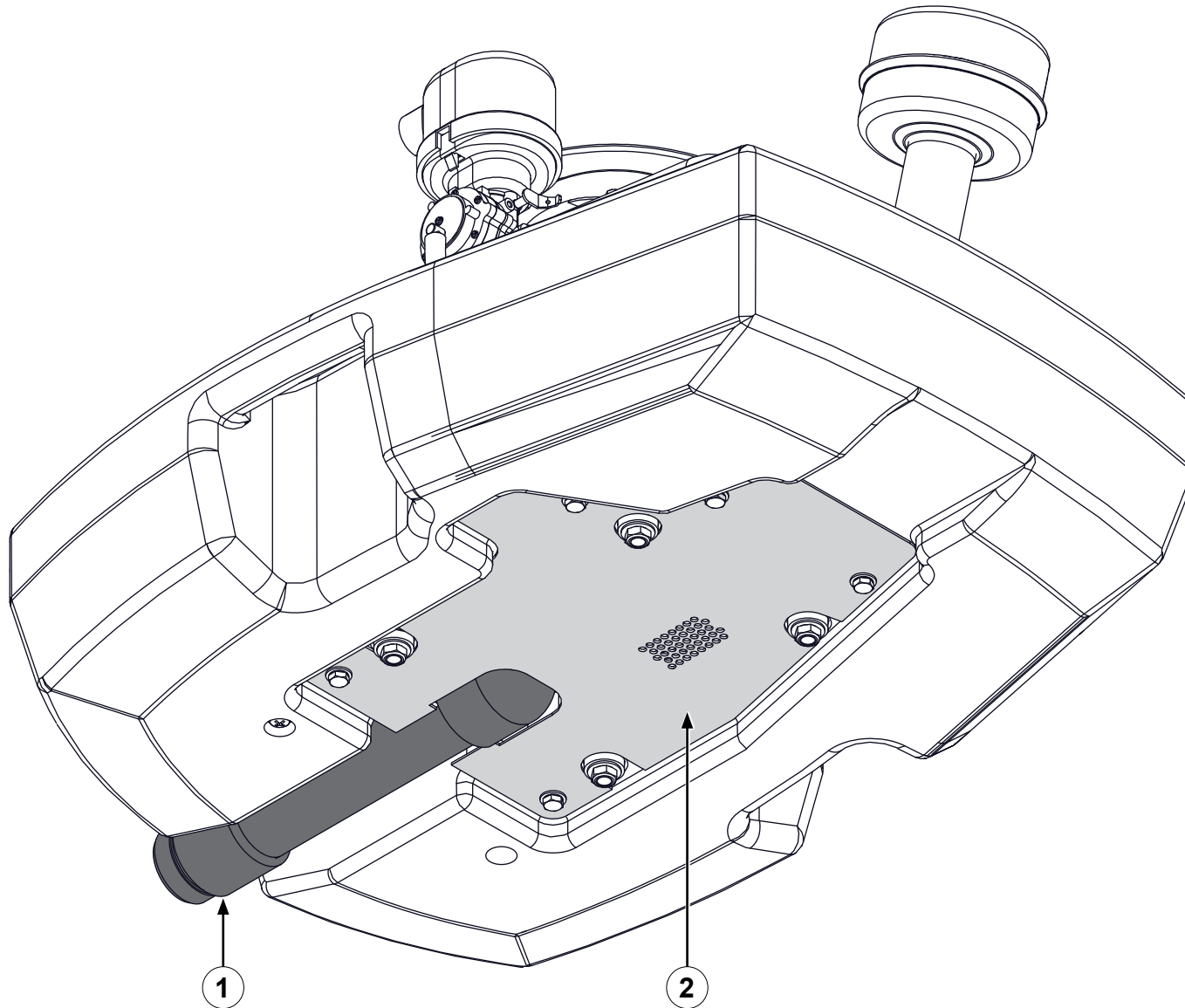

Bottom Side Components

	Feature	Description
1	Pump discharge	This is where the pump discharges water.
2	Intake screen	This screens the water before entering the pump.

Initial Operation

This equipment is intended to be operated by a person or persons with the basic knowledge of operating similar equipment. Contact Waterous with questions about operating the equipment. Operation may require the following abilities:

- Mixing gasoline and oil.
- Carburetor adjustment.
- Basic small engine operation.
- Basic small engine maintenance.

Preparing for the Operation

Read and understand all the installation instructions before operating the equipment.

NOTICE

Before Operation

- Read and understand all the instructions provided.
- Check all fluid levels and replenish if necessary.
- Remove the all shipping plugs and install the operation plugs or caps.



Operating Tips

Use the following guidelines when operating the FLOTO-PUMP:

- Never operate the pump in an enclosed space. Always operate the pump in an open or well ventilated space.

WARNING

Carbon Monoxide

- Carbon monoxide gas will kill you.
- Never operate the engine in an enclosed space.

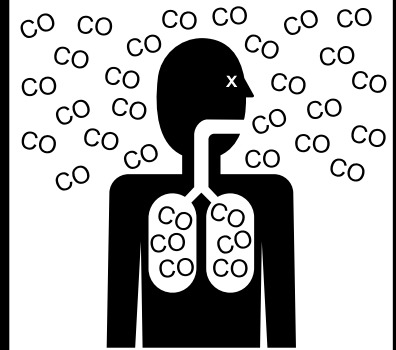

- Never touch the engine or fuel the pump when the engine is hot. Always allow the engine to cool before touching the engine or fueling.

WARNING

Hot Surface

- Hot surface can burn you.
- Do not touch the surface during operation—allow it to cool after operating.

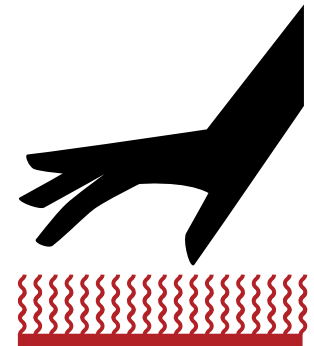

Fueling the Pump

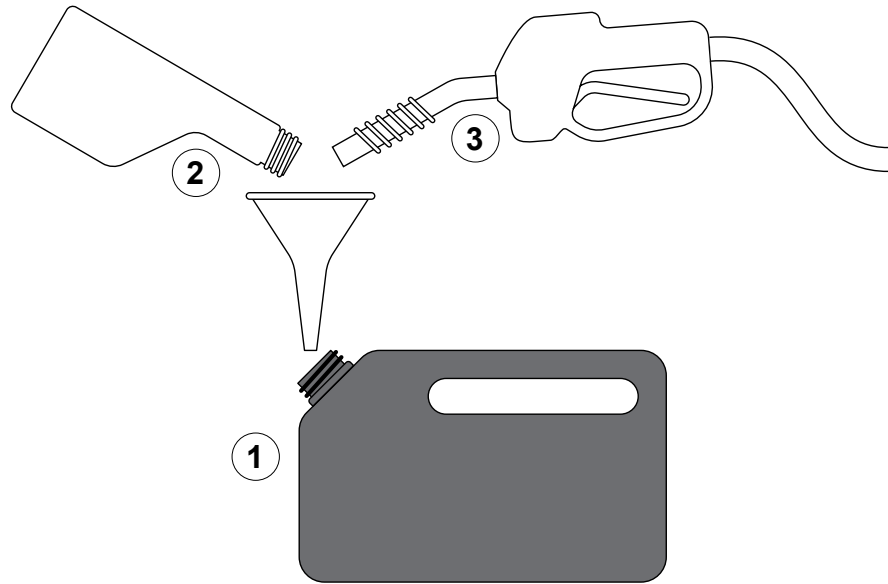

Use the illustrations and instructions to fuel the Floto pump. Locally source 2-cycle engine oil (National Marine Manufacturers Association TC-W3®) and gasoline.

Note: Use gasoline with a minimum octane of 87 and less than 10% alcohol.

- 1 Prepare a fuel container to mix the gasoline and oil before transferring it to the fuel tank.
- 2 Add oil to the container to make a 24:1 gasoline to oil mixture. Refer to the following:

Gasoline	Oil	Gasoline	Oil
1 US gallon	5.3 fl oz	1 L	42 ml
3 US gallons	16 fl oz	10 L	417 ml
5 US gallons	27 fl oz	20 L	833 ml

- 3 Add enough gasoline to the container to make a 24:1 mixture.
- 4 Remove the fuel cap and pour mixture into the fuel tank. Install the fuel cap after fueling.

Note: Allow the engine to cool after operating before fueling. Wipe up any fuel spills.

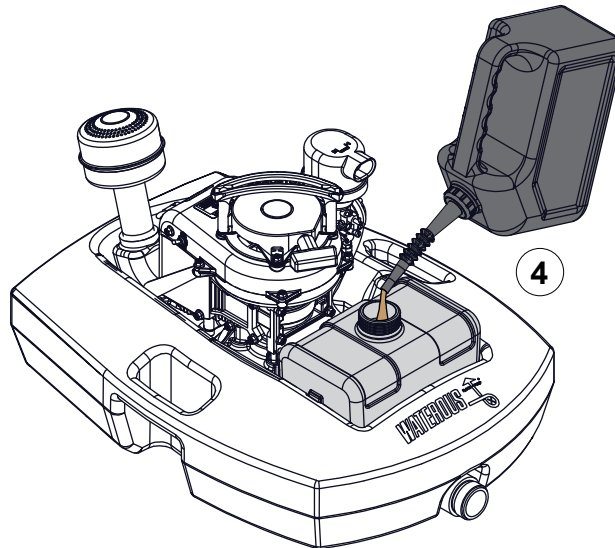

Connecting a Hose to the Pump

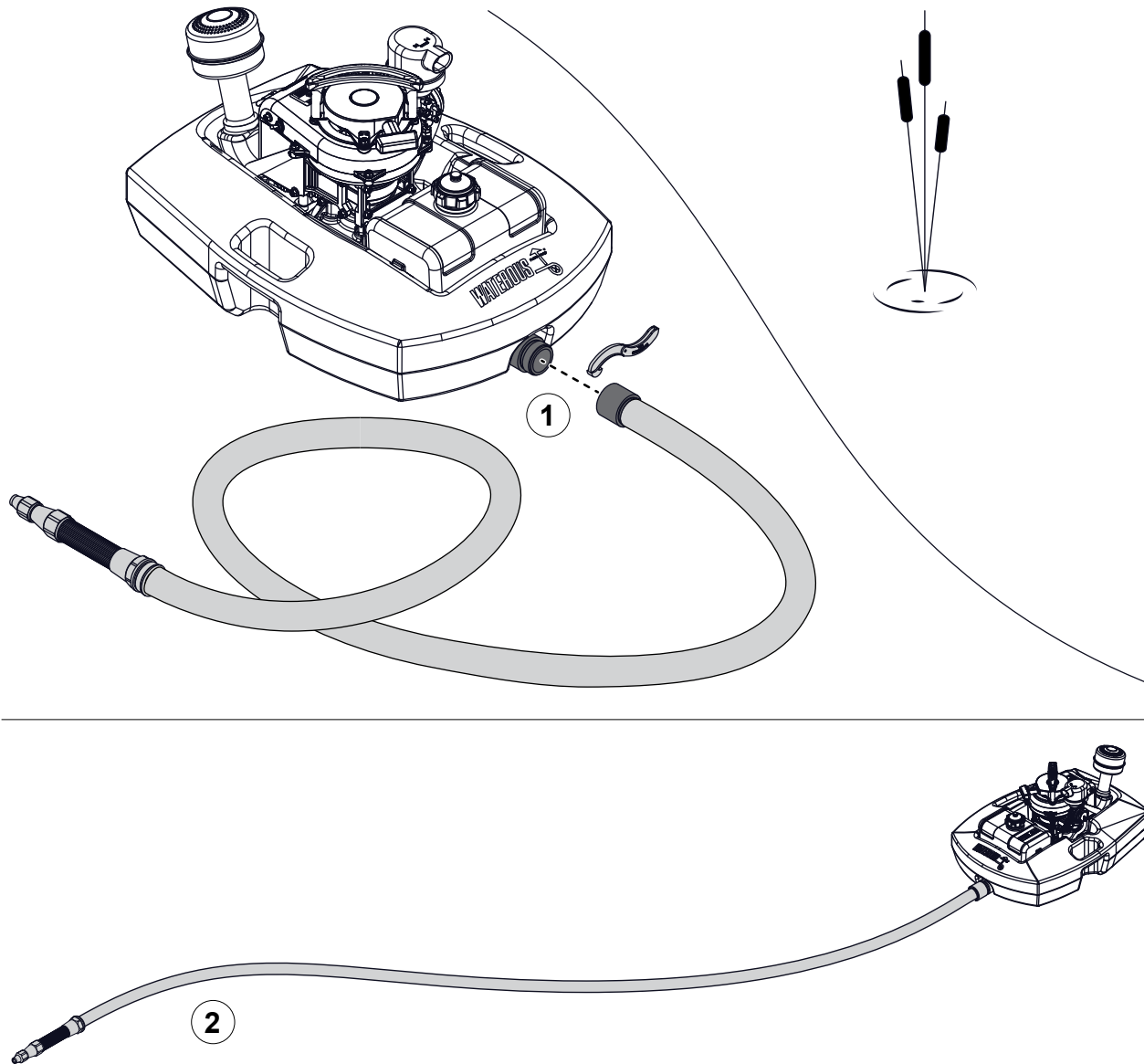

Use the illustrations and instructions to connect the hose to the pump.

- 1 Use the provided spanner wrench to secure the hose to the pump discharge.
- 2 Straighten the hose before starting the pump.

Starting and Stopping the Pump

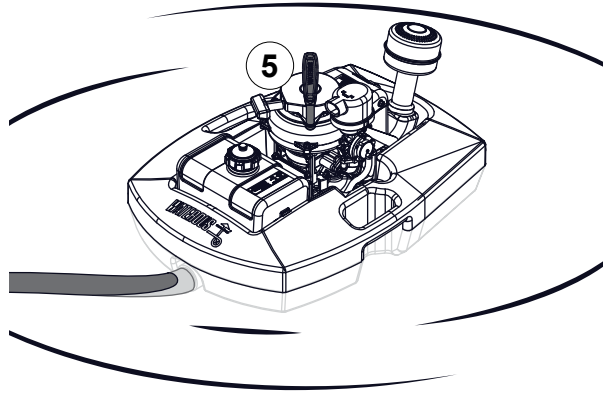
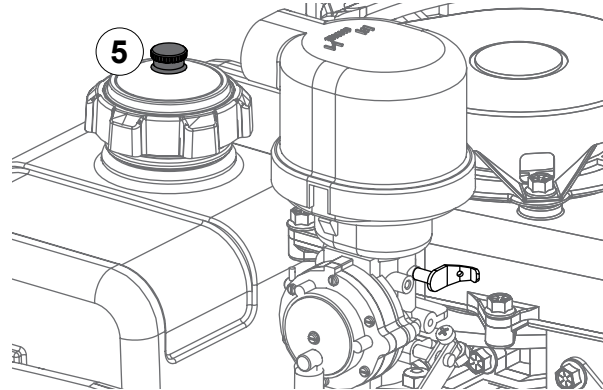
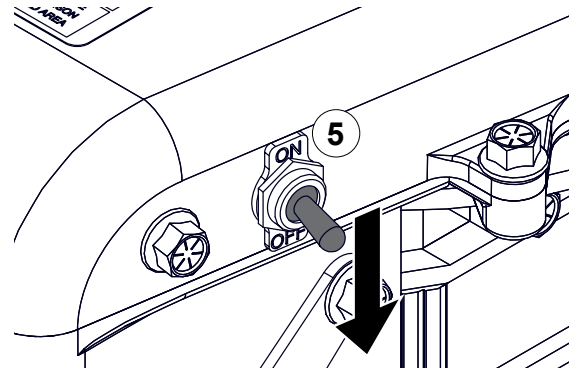
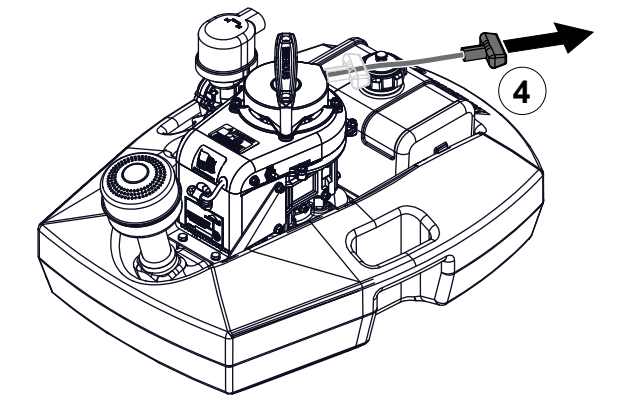
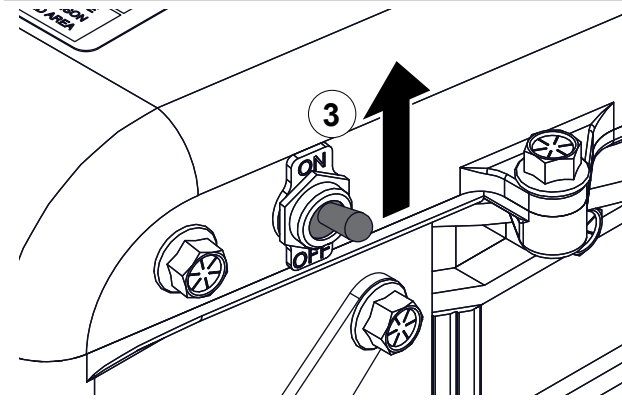
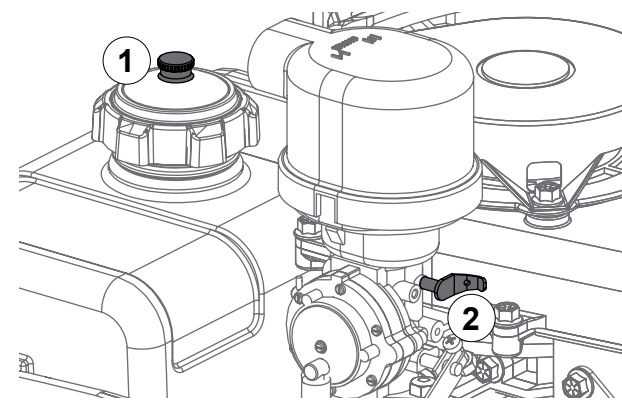

Use the illustrations and instructions to start and run the FLOTO-PUMP. Before you start the engine for the first time, it is suggested that you familiarize yourself with the pull distance and the force required to start a high compression engine.

- 1 Open the fuel vent.
- 2 Rotate the choke lever to close the choke.
- 3 Toggle the ON/OFF switch to the On position.
- 4 Grasp the start handle and pull it to start the engine. Open the choke once the engine is stable.

Note: The engine operates at idle until the Floto is placed on water when the throttle float increases the engine speed to operating levels.

- 5 Once you complete the operation, toggle the ON/OFF switch to the OFF position, close the fuel vent, and remove the Floto from the water using the provided handles .

CAUTION

Hearing Loss

- High sound levels will cause hearing loss.
- Wear hearing protection when operating this equipment.



Always wear hearing protection when operating the pump.

Operating the Pump

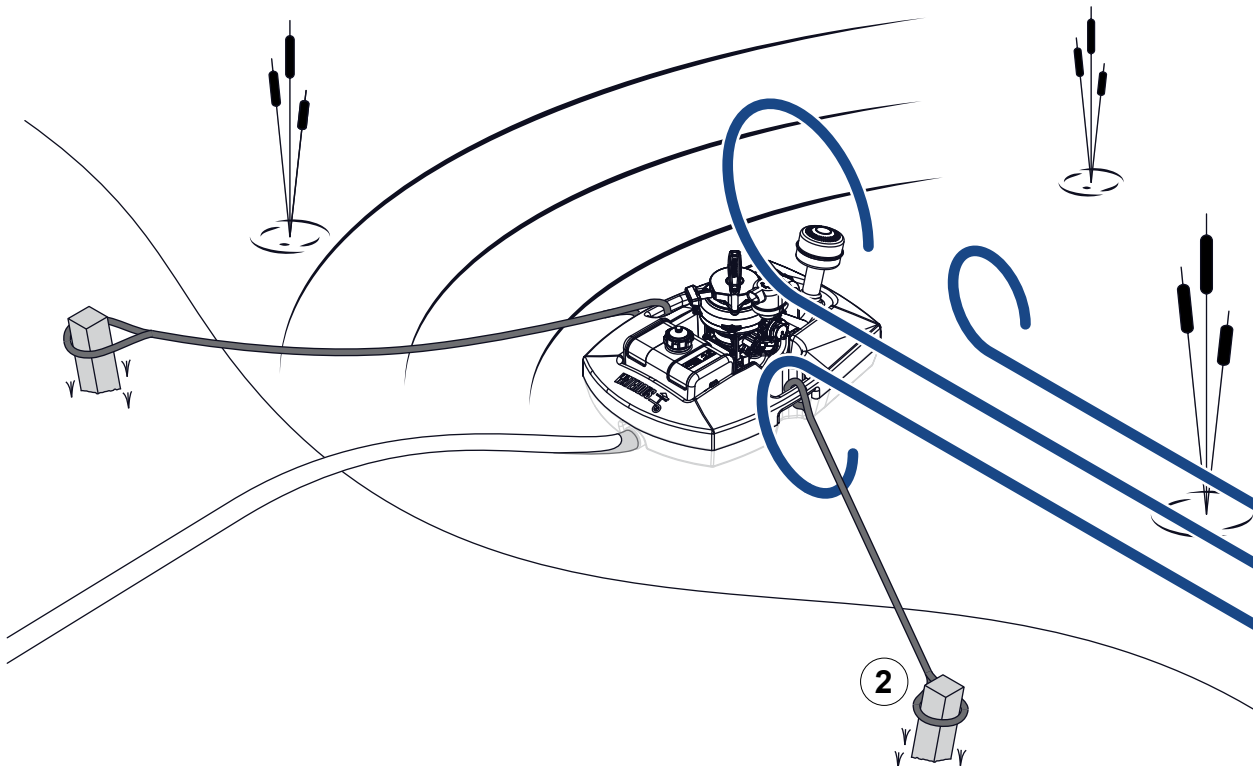
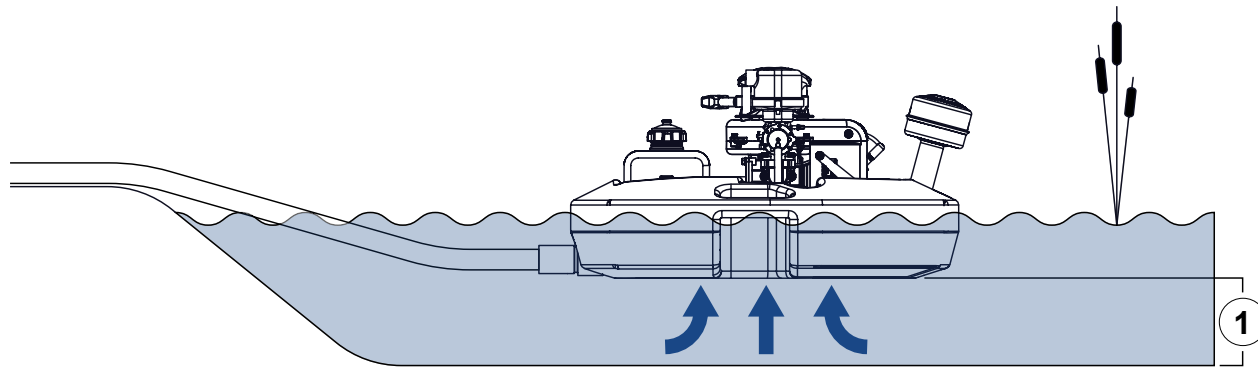

Use the illustrations and instructions as best practices when operating the FLOTO-PUMP.

- 1 Do not operate the pump in water depth of 6 inches (150 mm) or less. Do not operate the pump in a body of water that will deplete to less than 6 inches (150 mm) of water during operation.

! WARNING	
<p>Moving Parts</p> <ul style="list-style-type: none"> • Rotating parts can cause severe injury or death. • Keep clear of moving parts when the equipment is operating. 	

Always keep clear of the pump intake when operating the pump.

- 2 When operating in windy conditions, it may be necessary to use guy lines to stabilize the pump position.

Adjusting the Carburetor

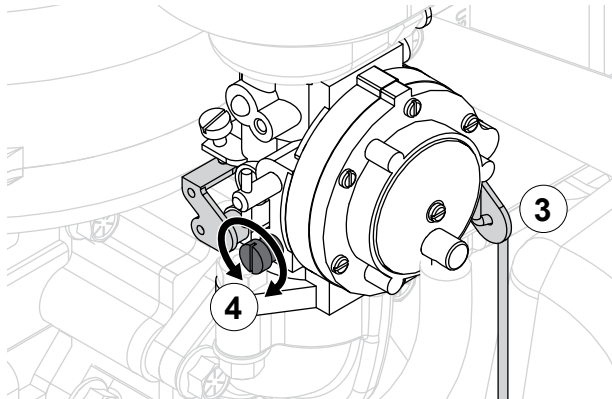
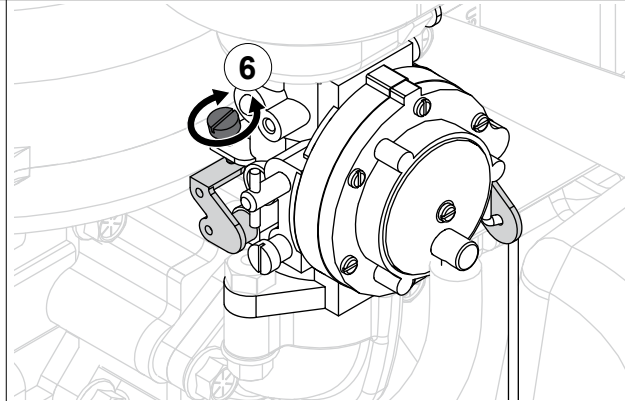
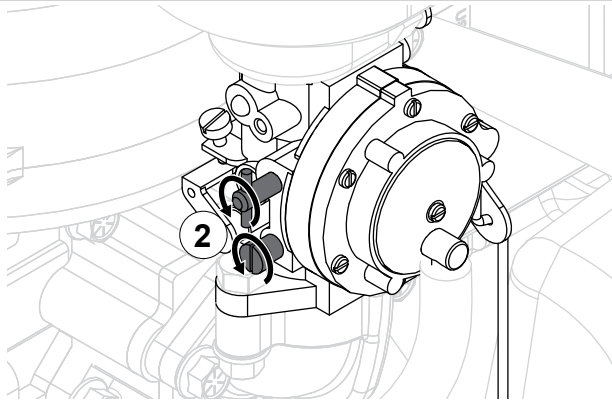
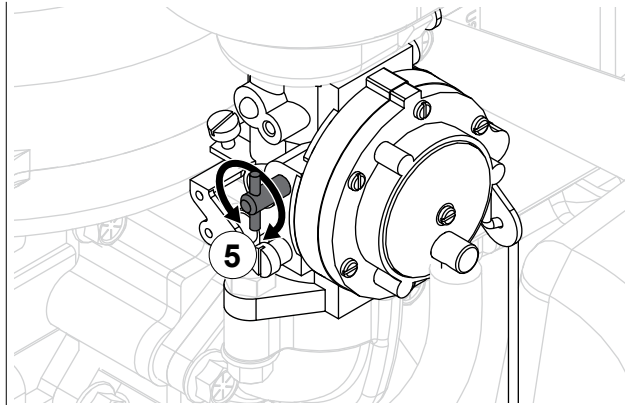
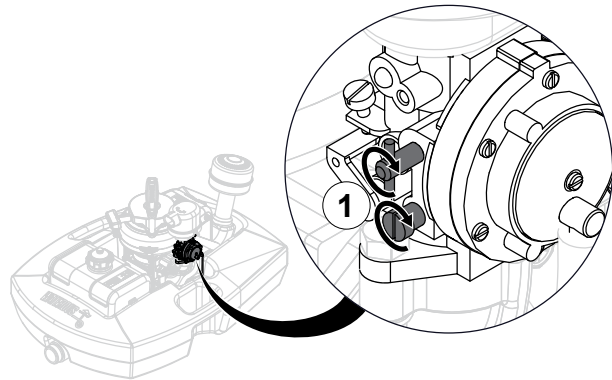

Use the illustrations and instructions to adjust the low and high speed idle. This adjustment can be performed with the pump out of the water, but may need fine tuning once in water and under load.

- 1 Locate the carburetor needle screws and turn them clockwise to close them.
 - 2 Turn each needle 1 turn counterclockwise.
 - 3 Start the engine and use the throttle float manually to manage the engine operation.
 - 4 With the engine at idle, adjust the low speed idle screw until you achieve the desired performance.
 - 5 Use the throttle float to slowly increase the engine speed. Adjust the high speed idle screw until you achieve the desired performance.
- Note:** Avoid leaning-out the fuel to the carburetor as piston seizure can occur.
- 6 Use the idle screw to adjust the idle speed.

Adjusting the Throttle Float

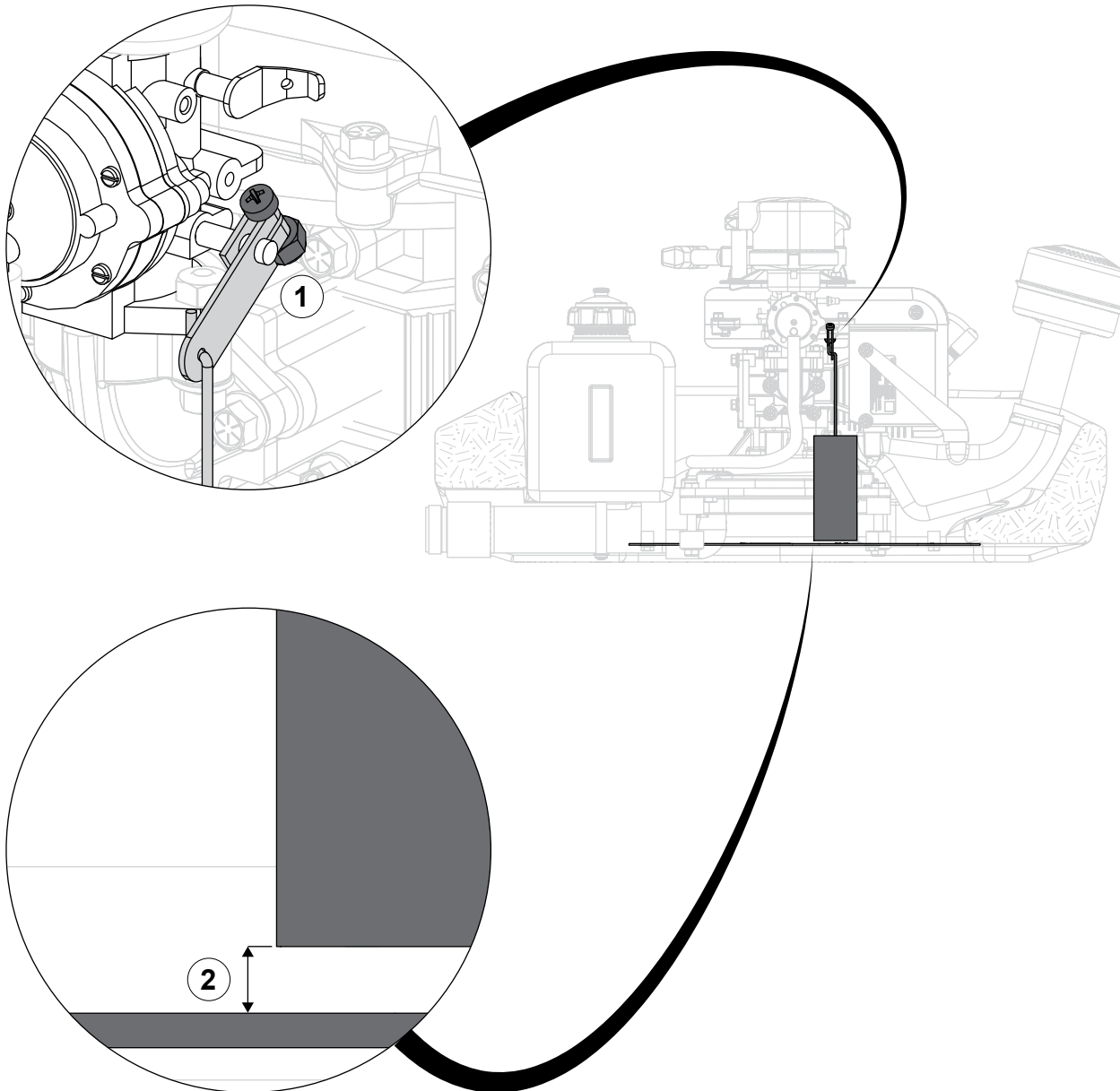

Use the illustrations and instructions to adjust the throttle float.

- 1 Locate and loosen the hardware securing the throttle float lever.
- 2 Rotate the lever until the throttle float touches the intake screen, then raise it 1/8 inch (3 mm). Use the hardware to secure the position.

NOTICE

Modification

- Modifying the equipment can damage components and void your warranty.
- Do not modify the system or any of its components.

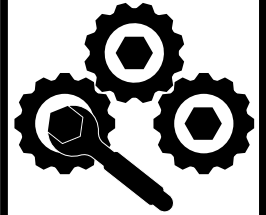

Do not modify components that govern the engine speed. Doing so can damage the equipment and will void your warranty.

Preparing the FLOTO-PUMP for Short Term Storage

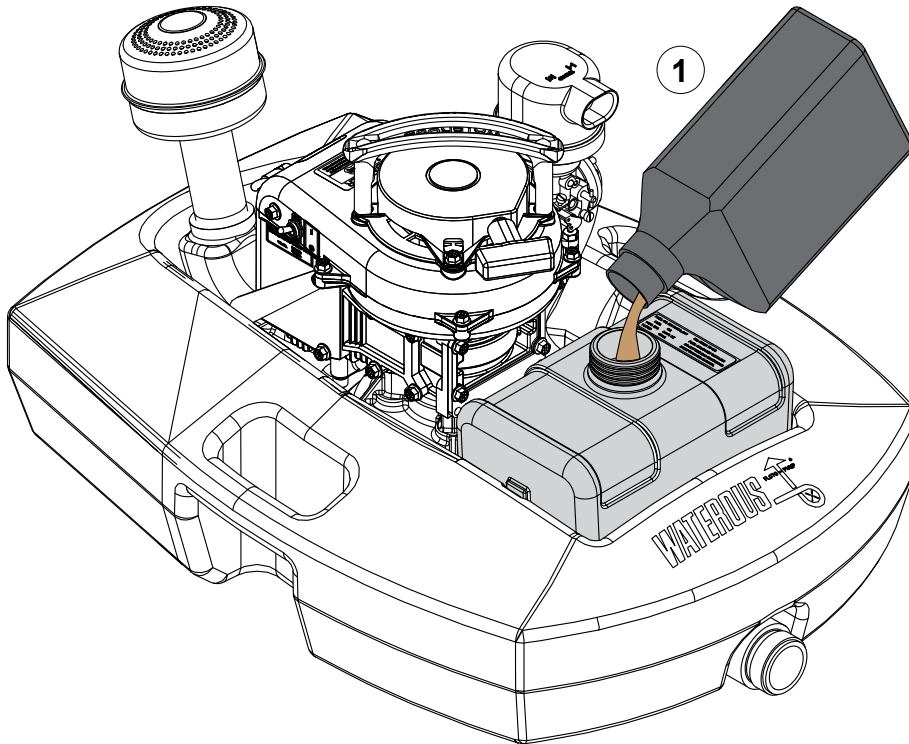

Use the illustrations and instructions to prepare the FLOTO-PUMP for short term storage—2 months or less.

- 1 If you won't be operating the pump for a few weeks, add a fuel stabilizer to the fuel tank, cover the pump, and put it into storage.

Preparing the FLOTO-PUMP for Long Term Storage

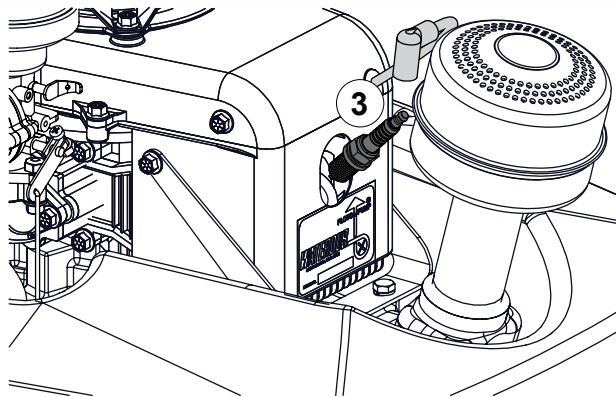
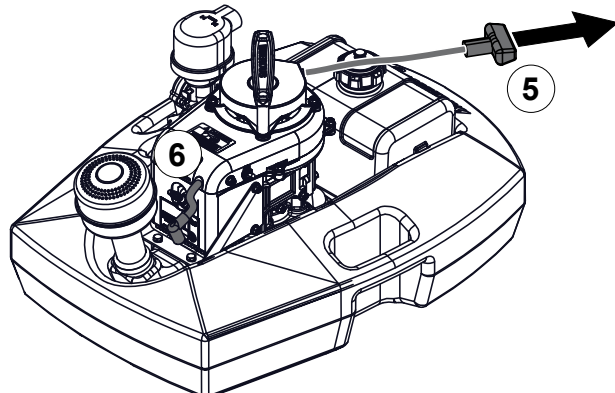
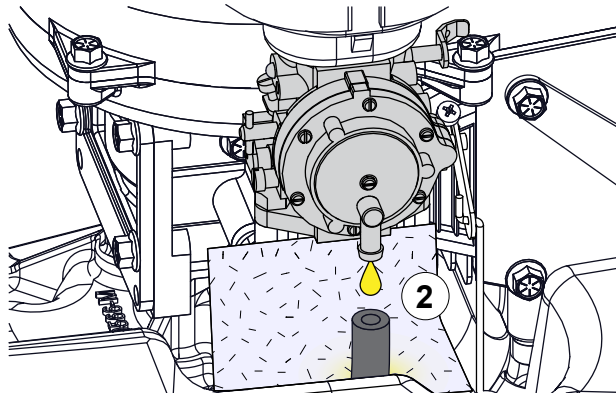
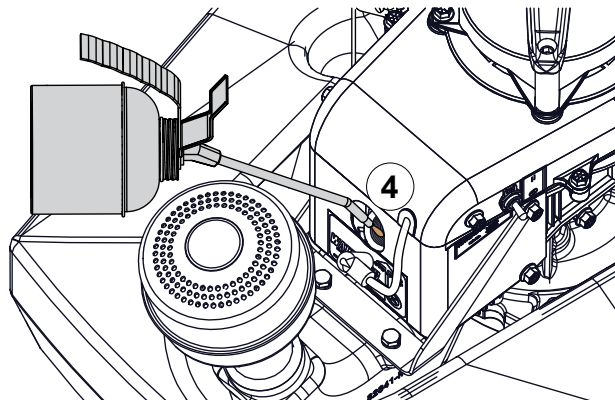
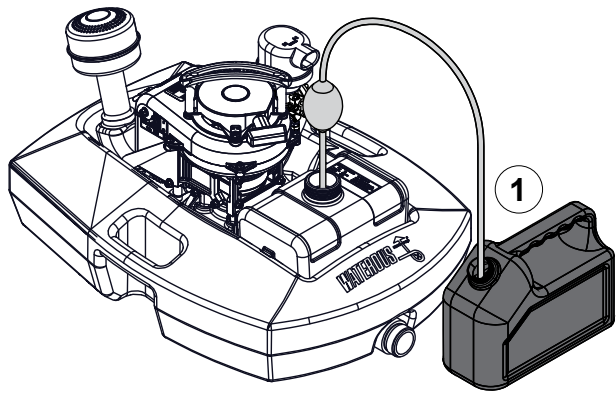

Use the illustrations and instructions to prepare the FLOTO-PUMP for long term storage—2 months or longer.

- 1 Siphon the fuel from the fuel tank. Continue to next instruction.
- 2 Prepare a rag to collect fuel that flows from the carburetor. Remove the fuel line from the carburetor and capture the fuel to drain.
- 3 Remove the spark plug cable, then remove the spark plug and set it aside.
- 4 Apply 3 or 4 squirts of oil—the same oil that you use to mix with gasoline—into the piston cylinder.
- 5 Pull the start handle a few times to coat the cylinder walls with oil.
- 6 Install the spark plug that you set aside earlier.

Note: Make sure that the spark plug is in working condition.

- Do not use a fouled spark plug.
- Make sure that the spark plug is properly gapped—0.030 inch.
- Replace with NGK BR9HS (14 mm) spark plug, or equivalent if necessary.

Install the spark plug cable, cover the pump, and put it into storage.

Engine, Replacement Assemblies, and Repair Kits

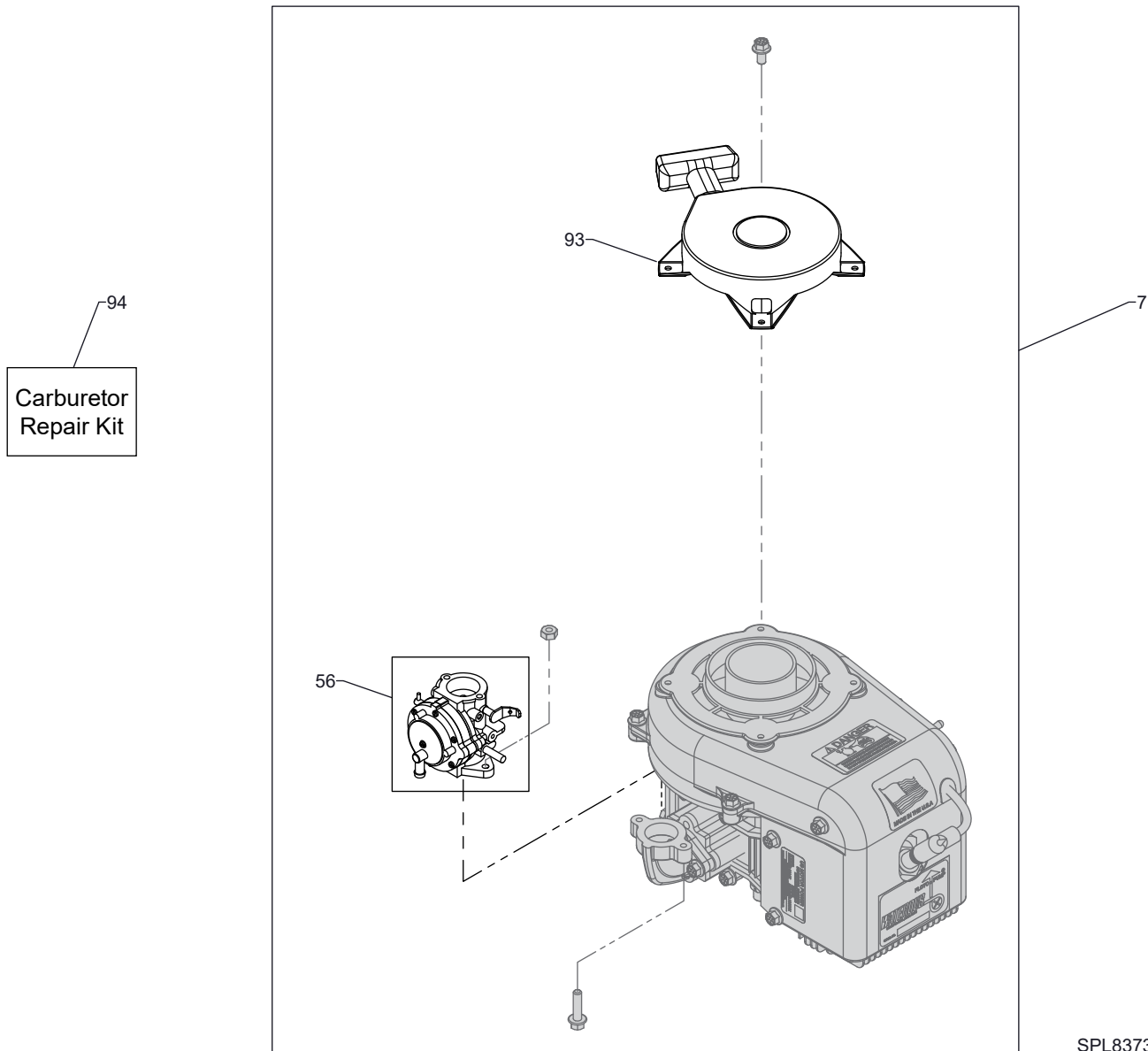

SPL83736

Engine, Replacement Assemblies, and Repair Kits

The following repair kit and assemblies are available from Waterous. Additional motor components are available from U.S. Motor Power. Use the label on the engine to determine the engine model and serial number.

Description	
7	Engine
56	Carburetor replacement assembly— Note: Use the original mounting hardware to install.
93	Starter replacement assembly— Note: Use the original mounting hardware to install.
94	Carburetor repair kit

Additional Engine Specifications

- Horsepower: 8 horsepower
- Bore: 2.531 inches
- Stroke: 1.62 inches
- Displacement: 8.2 cubic inches—134 cubic centimeters
- Mounting: In any position
- Cooling: air-cooled
- Starter: automatic rewind
- Ignition: PVL electronic ignition
- Spark plug: NGK BR9HS, 14 mm, gap: 0.030 inch
- Cylinder: aluminum die-cast crankcase cylinder with removable cylinder head
- Cylinder Bore: Nikasil plated
- Bearings: flywheel and power take-off end—ball bearings
- Bearings: upper connecting rod—needle bearings
- Bearings, lower connecting rod: needle bearings
- Connecting rod: forged steel
- Crankshaft: forged steel
- Piston: aluminum alloy
- Rings: compression—2
- Carburetor location: variable—3 positions possible
- Carburetor type: diaphragm with integral fuel pump—permits engine to operate in all positions
- Fuel: gasoline—regular unleaded
- Oil: 2 cycle—National Marine Manufacturers Association TC-W3®
- Fuel/oil mix: 24:1
- Lubrication: self-lubrication with oil in fuel
- Weight: approximately 15-1/2 lb

Float and Fuel System Components—Standard FLOTO-PUMP

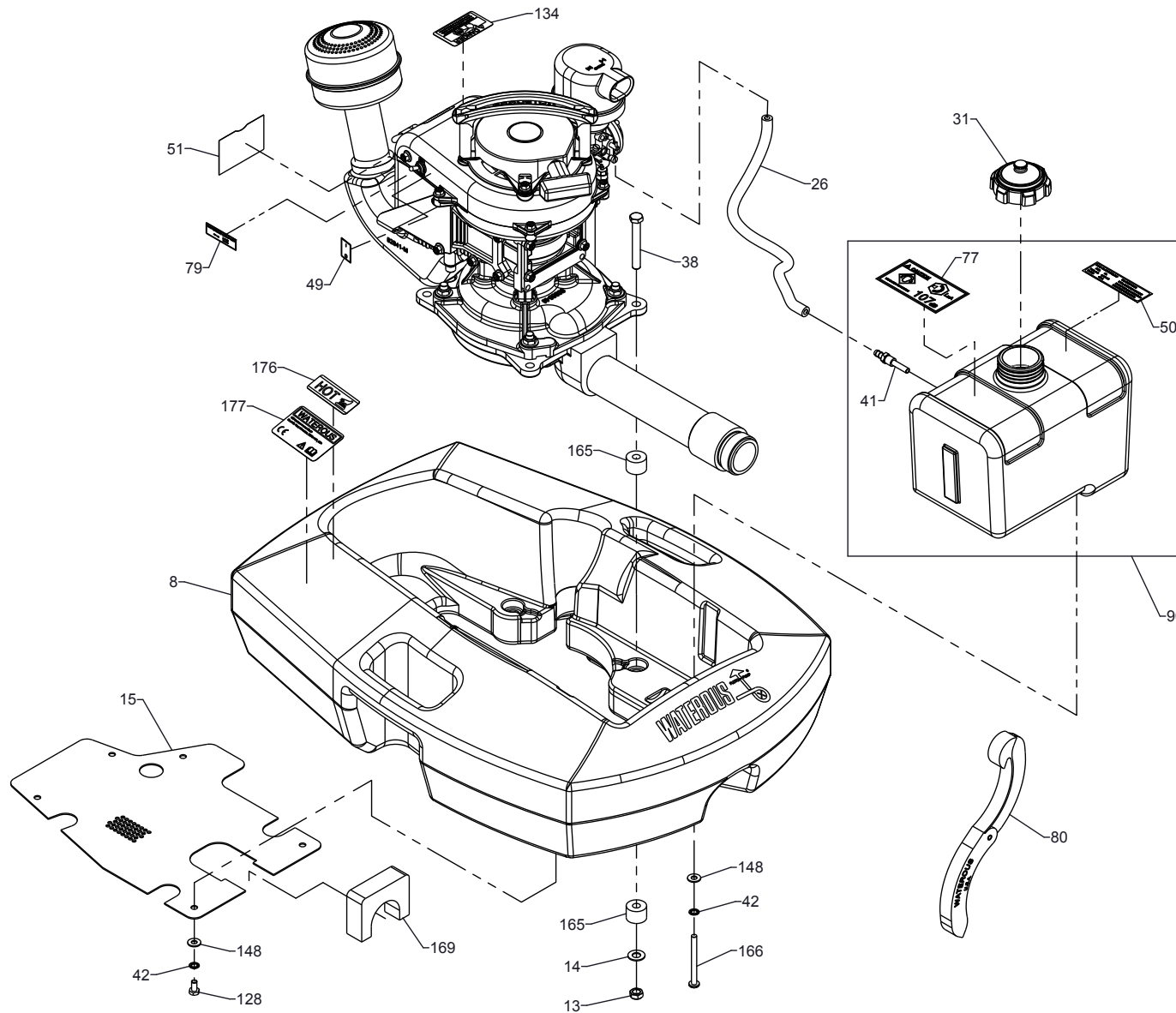

Float and Fuel System Components—Standard FLOTO-PUMP

Description	
8	Float
13	Locknut—3/8-16
14	Plain washer—3/8 inch
15	Intake screen
26	Fuel line
31	Fuel tank cap
38	Screw—3/8-16 x 2-3/4 inches
42	Lock washer—1/4 inch
49	Run stop decal
51	Name plate decal—includes pump serial number
79	Patent decal
80	Spanner wrench
90	Fuel tank subassembly
41	Fuel line filter
50	Fuel mix decal
77	Hearing protection warning decal
128	Screw—1/4-20 x 1/2 inch
134	Carbon monoxide warning label
148	Washer—1/4 inch
165	Rubber bushing
166	Screw—1/4-20 x 2-3/4 inches
169	Inlet chamber seal
177	CE marking decal
179	Hot warning decal

Exhaust and Air System Components—Standard FLOTO-PUMP

Description	
23	Throttle control float
25	Throttle arm
35	Locknut—#10-24
170	Screw—#10-24 x 5/8 inch
187	Engine replacement kit
1	Air intake cover
3	Lock washer—#10
6	Lifting handle
7	Engine— Note: Use the original mounting hardware to install.
16	Mechanical seal—not illustrated, refer to Page 32 .
28	Screw—#10-32 x 3/8 inch, Note: Apply temporary thread lock to the screw before installing.
29	Screw—1/4-20 x 2-1/2 inches
42	Lock washer—1/4 inch
44	Muffler
45	Exhaust adapter
46	O-ring—7-1/4 x 7-1/2 inches, not illustrated, refer to Page 32 .
65	Air intake base
82	Muffler bracket
128	Screw—1/4-20 x 1/2 inch
153	Lock washer—1/4 inch
178	Pipe nipple—1-1/4 NPT x 5 inches
179	Air intake screen
185	Lock washer—5/16 inch
186	Screw—5/16-18 x 1-3/4 inches

Pump and Impeller Components—Standard FLOTO-PUMP

Description	
7	Engine
12	Screw—3/8-16 x 1-1/2 inches
13	Locknut—3/8-16
14	Washer—3/8 inch
16	Mechanical seal—included with engine replacement kit #187, refer to Page 30 .
18	Impeller
19	Dowel pin—5/16 x 3/4 inch
20	Upper volute body
21	Screw—5/16-18 x 1-1/2 inches
22	Lower volute body
	Discharge nipple—1-1/2 NPSH x 11 inches
36	Discharge nipple—1-1/2 BSP x 11 inches
	Discharge nipple—1-1/2 NPT x 8-7/8 inch, requires #37 discharge nozzle
37	Discharge nozzle—1-1/2 NH, used with #36, 1-1/2 NPT discharge nipple
46	O-ring—7-1/4 x 7-1/2 inches, included with engine replacement kit #187, refer to Page 30 .

Float and Fuel System Components—High Pressure FLOTO-PUMP

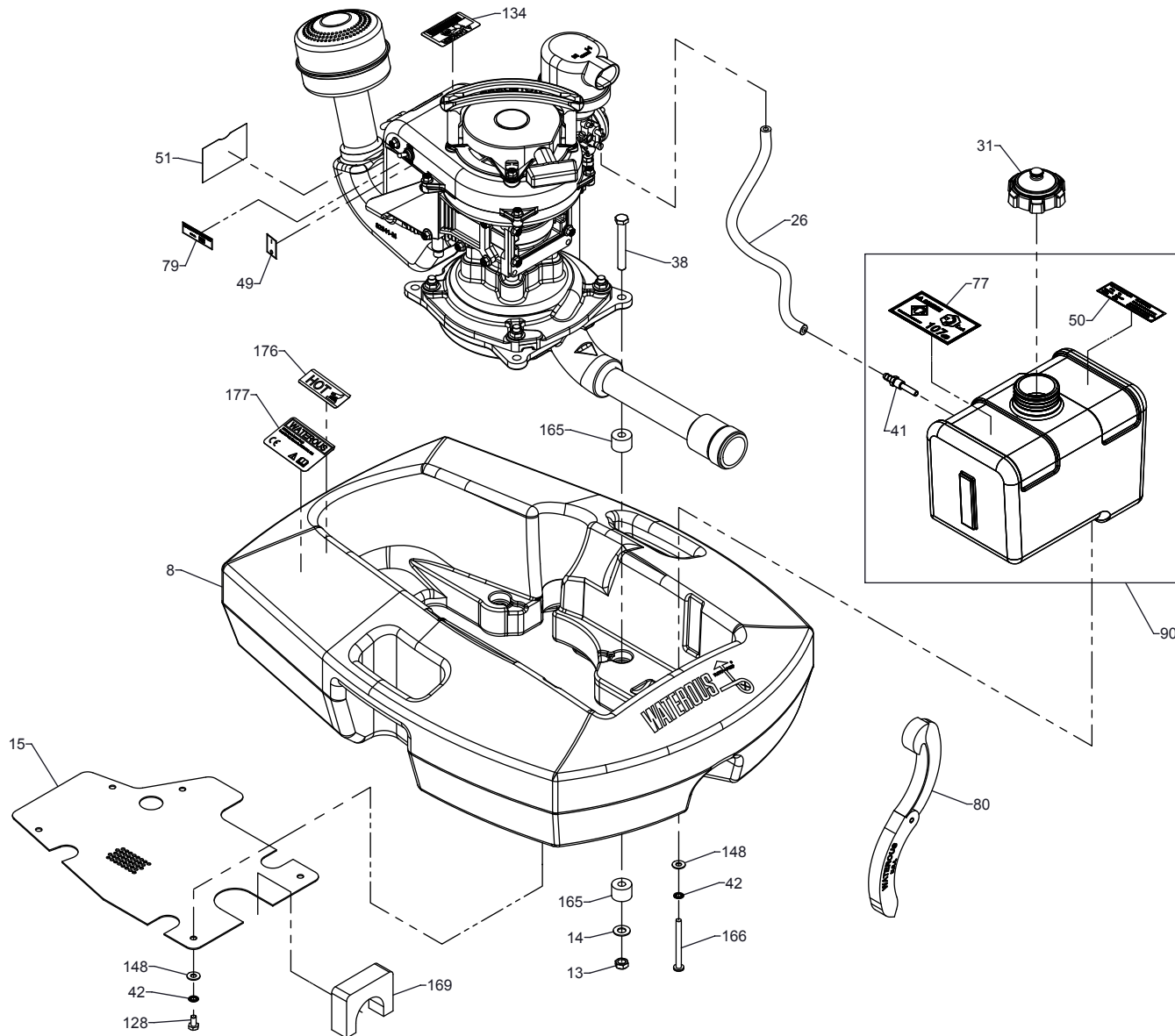

SPL83736

Float and Fuel System Components—High Pressure FLOTO-PUMP

Description	
8	Float
13	Locknut—3/8-16
14	Washer—3/8 inch
15	Intake screen
26	Fuel line
31	Fuel tank cap
38	Screw—3/8-16 x 2-3/4 inches
42	Lock washer—1/4 inch
49	Run stop decal
51	Name plate decal—includes pump serial number
79	Patent decal
80	Spanner wrench
90	Fuel tank subassembly
41	Fuel line filter
50	Fuel mix decal
77	Hearing protection warning decal
128	Screw—1/4-20 x 1/2 inch
134	Carbon monoxide warning label
148	Washer—1/4 inch
165	Rubber bushing
166	Screw—1/4-20 x 2-3/4 inches
169	Inlet chamber seal
177	CE marking decal
179	Hot warning decal

Exhaust and Air System Components—High Pressure FLOTO-PUMP

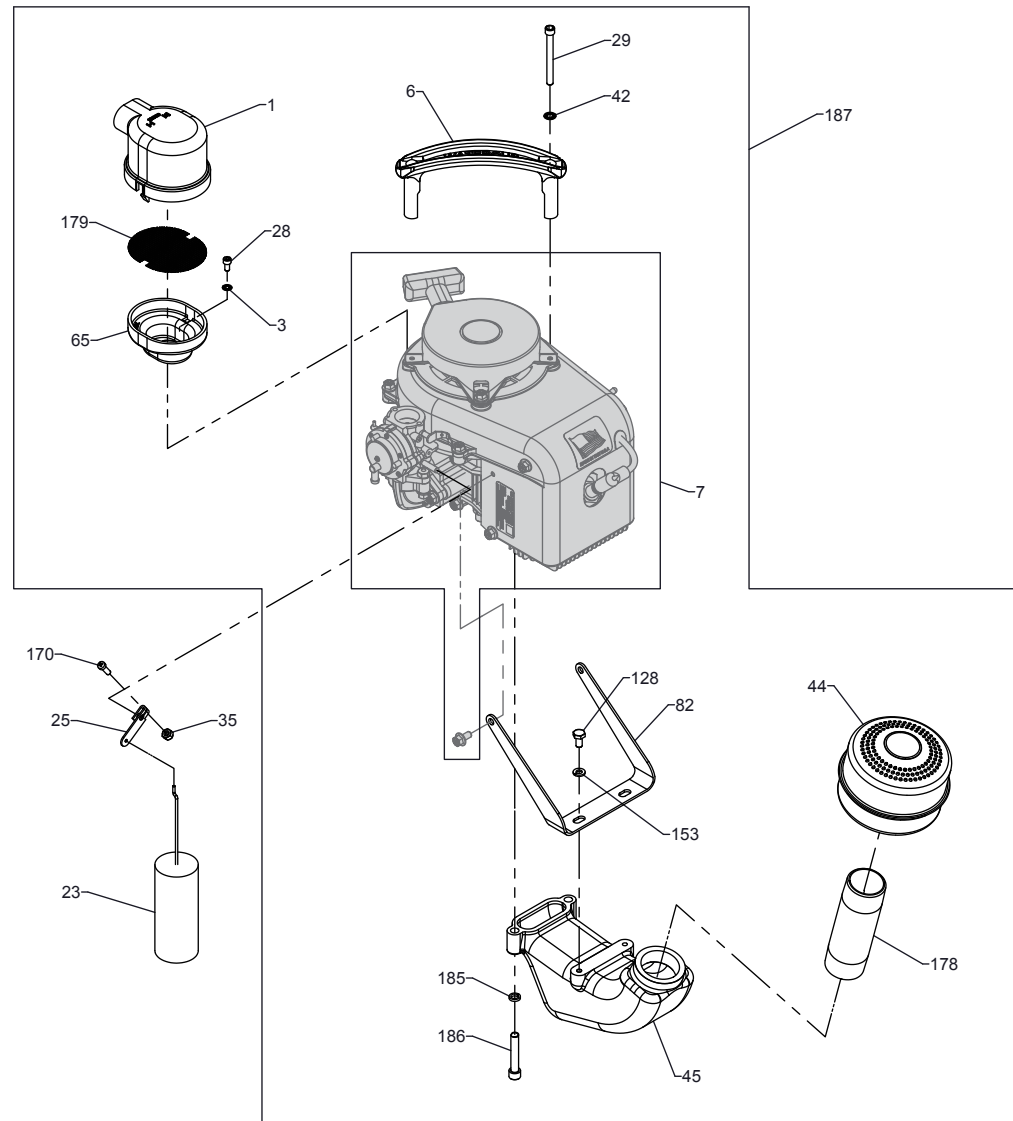

Exhaust and Air System Components—High Pressure FLOTO-PUMP

Description	
23	Throttle control float
25	Throttle arm
35	Locknut—#10-24
170	Screw—#10-24 x 5/8 inch
187	Engine replacement kit
1	Air intake cover
3	Internal tooth lock washer—#10
6	Lifting handle
7	Engine— Note: Use the original mounting hardware to install.
16	Mechanical seal—not illustrated, refer to Page 38 .
28	Screw—#10-32 x 3/8 inch, Note: Apply temporary thread lock to the screw before installing.
29	Screw—1/4-20 x 2-1/2 inches
42	Lock washer—1/4 inch
44	Muffler
45	Exhaust adapter
46	O-ring—7-1/4 x 7-1/2 inches, not illustrated, refer to Page 38 .
65	Air intake base
82	Muffler bracket
128	Screw—1/4-20 x 1/2 inch
153	Lock washer—1/4 inch
178	Pipe nipple—1-1/4 NPT x 5 inches
179	Air intake screen
185	Lock washer—5/16 inch
186	Screw—5/16-18 x 1-3/4 inches

Pump and Impeller Components—High Pressure FLOTO-PUMP

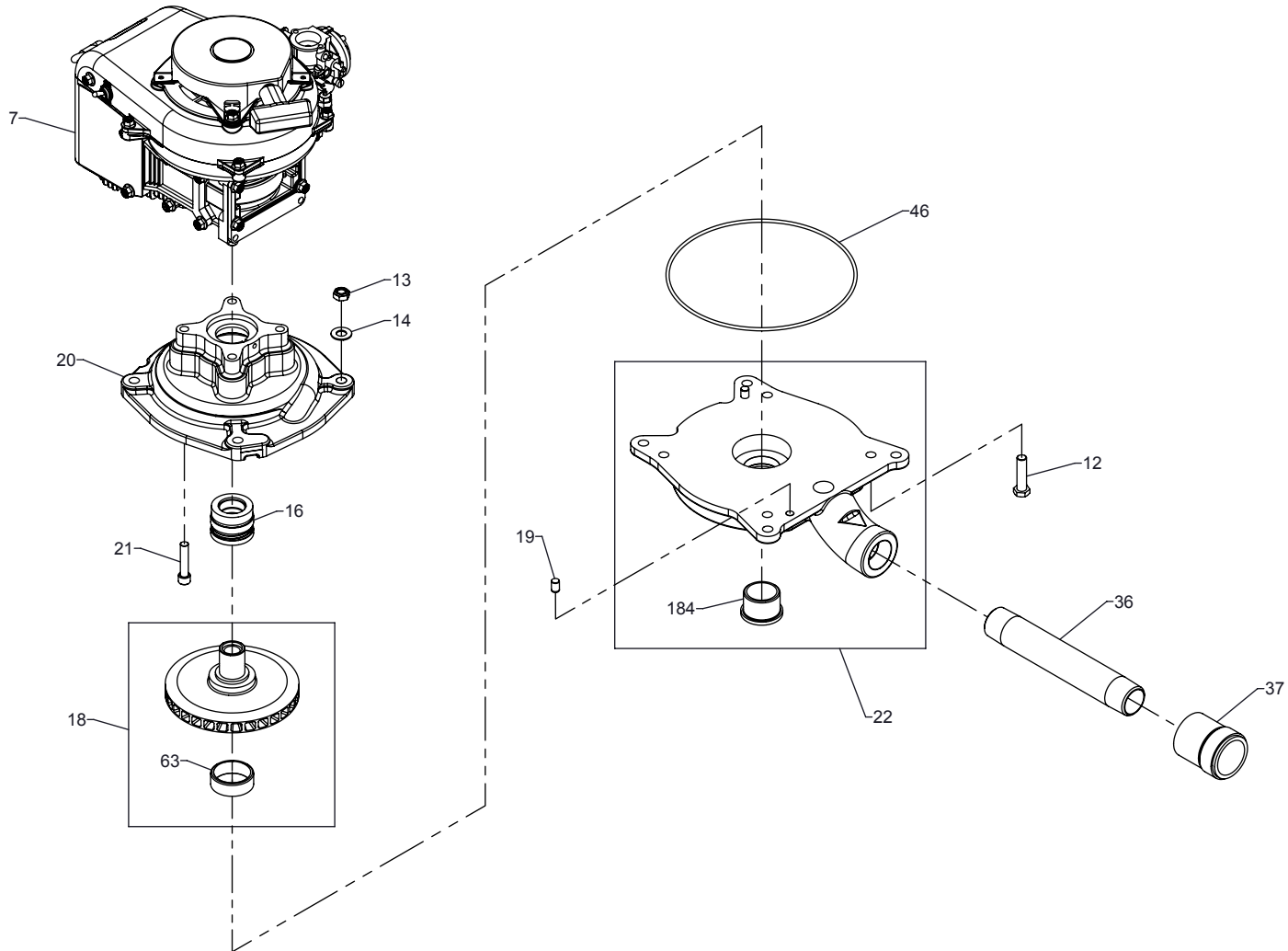

Pump and Impeller Components—High Pressure FLOTO-PUMP

Description	
7	Engine
12	Screw—3/8-16 x 1-1/2 inches
13	Locknut—3/8-16
14	Washer—3/8 inch
16	Mechanical seal—included with engine replacement kit #187, refer to Page 36 .
18	Impeller
63	Impeller bushing
19	Dowel pin—5/16 x 3/4 inch
20	Upper volute body
21	Screw—5/16-18 x 1-1/2 inches
22	Lower volute body
184	Volute bushing—flanged
36	Pipe nipple—1 NPT x 7-3/4 inches
37	Discharge nozzle—1-1/2 NH, 1-1/2 NPSH, or 1-1/2 BSP
46	O-ring—7-1/4 x 7-1/2 inches, included with engine replacement kit #187, refer to Page 36 .

Troubleshooting

Problem	Possible Cause	Solution
The engine does not start.	No fuel in the tank.	Add fuel to the tank. Refer to "Fueling the Pump" on page 17.
	The ignition switch is in the <i>OFF</i> position.	Toggle the switch to the <i>ON</i> position. Refer to: "Starting and Stopping the Pump" on page 19.
	Fuel tank vent closed.	Open the fuel vent. Refer to: "Starting and Stopping the Pump" on page 19.
	Fuel line or fuel tank screen clogged.	Clean or replace the fuel line and/or fuel screen.
	The carburetor is flooded.	<ul style="list-style-type: none"> • Hold throttle in fast position and crank engine. • Close carburetor main adjustment needle and crank until the engine starts. Then turn needle to 1 turn open.
	The spark plug is not working properly.	Replace the spark plug. Refer to: "Additional Engine Specifications" on page 27 for the spark plug specifications.
	The spark plug wire is not working properly.	Replace the spark plug wire.
	The ignition system is not operating properly.	Contact Waterous for more information.
The engine is difficult to start.	The fuel is bad.	Drain and replace the fuel with fresh fuel.
	The fuel mixture contains too much oil.	Drain and replace the fuel with properly mixed fuel.
	The engine is not properly choked.	Adjust the choke. Refer to: "Starting and Stopping the Pump" on page 19.
	The carburetor is out of adjustment.	Adjust the carburetor. Refer to: "Adjusting the Carburetor" on page 21.
	The carburetor or reed plate gaskets are leaking.	Replace the damaged gaskets.
	Weak spark at lead wire.	Contact Waterous for more information.
The engine is misfiring.	The carburetor is dirty or malfunctioning.	Clean or repair the carburetor.
	The fuel is old, contaminated, or deteriorated.	Drain and replace the fuel with fresh fuel.
	The spark plug is fouled or malfunctioning.	Clean or adjust the spark plug. Refer to: "Additional Engine Specifications" on page 27 for the spark plug specifications.
	The lead wire has weak or insufficient spark.	Contact Waterous for more information.

Troubleshooting

Problem	Possible Cause	Solution
The engine lacks power.	The air cleaner is clogged.	Clean or replace the air cleaner.
	The carburetor is out of adjustment.	Adjust the carburetor. Refer to: "Adjusting the Carburetor" on page 21.
	The muffler is clogged.	Clean or replace the muffler.
	The engine exhaust port is clogged.	Clean the carbon buildup from the exhaust ports.
	The cylinder compression is poor.	Contact Waterous for more information.
The engine overheats.	The fuel mixture contains insufficient oil.	Replace the fuel with fuel with proper mixture. Refer to "Fueling the Pump" on page 17.
	The air flow is obstructed.	Clean any debris on or around the flywheel and cooling fins.
The engine is noisy or knocking.	The flywheel is loose.	Make sure that the flywheel nut is tight.
	The wrong spark plug was installed.	Make sure that the specified spark plug is installed. Refer to: "Additional Engine Specifications" on page 27 for the spark plug specifications.
	The cylinder rings, wall, or bearing are worn.	Contact Waterous for more information.
	The fan is bent.	Repair or replace the fan.
The engine stalls under load.	The carburetor is out of adjustment.	Adjust the carburetor. Refer to: "Adjusting the Carburetor" on page 21.
	The engine is overheating.	<ul style="list-style-type: none"> • Replace the fuel with fuel with proper mixture. Refer to "Fueling the Pump" on page 17. • Clean any debris on or around the flywheel and cooling fins.

WATEROUS

Waterous Company
125 Hardman Avenue South
South Saint Paul, MN 55075
(651) 450-5000
www.waterousco.com