

Q Series Transmissions TQ Series Power Take-Off's Operation and Maintenance Instructions

Table of Contents

Safety Information.....2
General Information..... 2
Maintenance:
 Lubrication Requirements..... 2
Lubrication Diagrams:
 Model QA..... 3
 Models QB and TQB..... 3
Models QC and TQC:
 Without Bellhousing Adapter... 4
 With Bellhousing Adapter..... 5

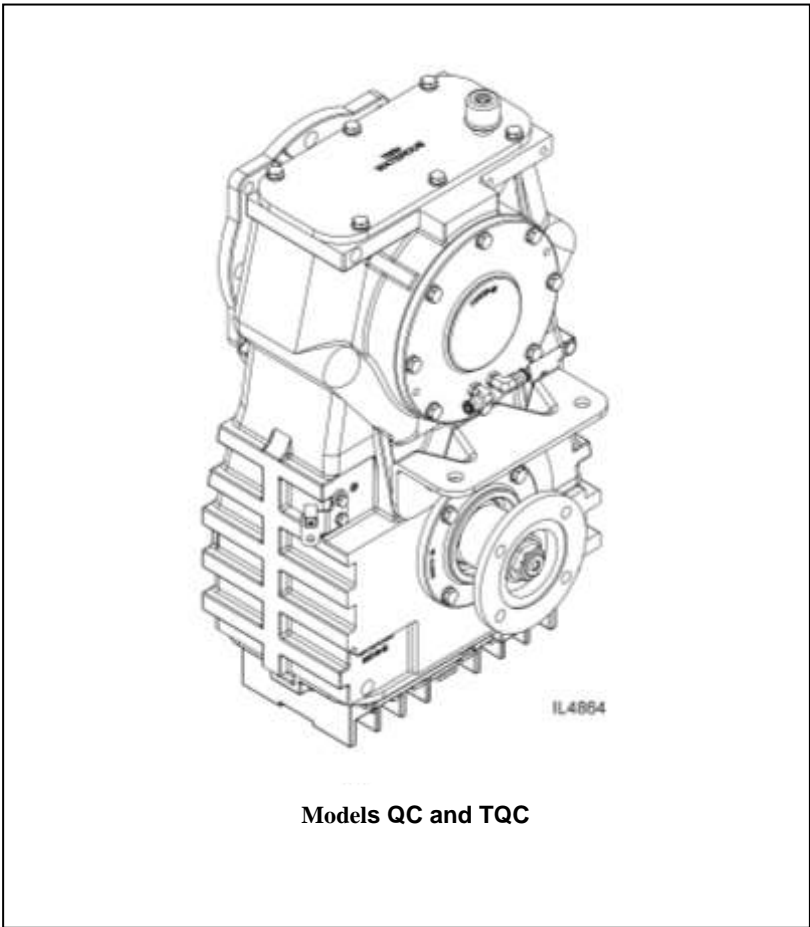
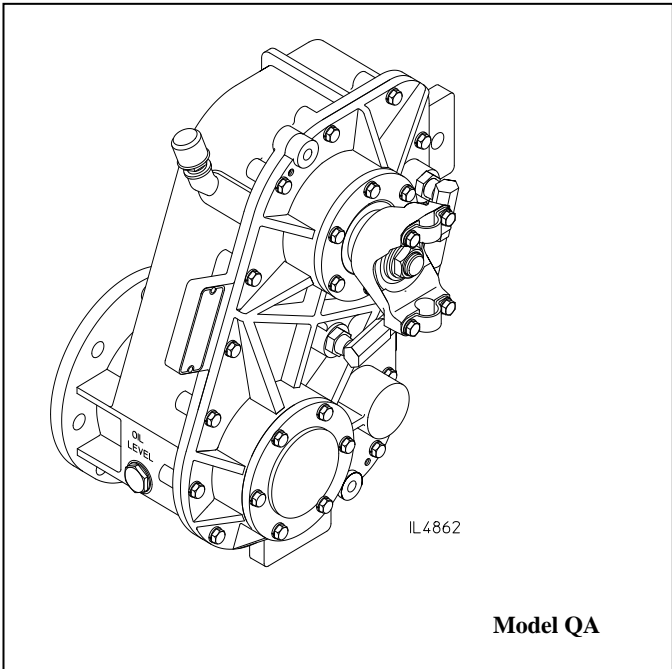

NOTE: Instructions subject to change without notice.

F-2875 (Issued: 5/12/22)



Read through the operation instructions carefully before using your Waterous transmission or PTO.

Safety Information



WARNING

Death or serious personal injury might occur if proper operating procedures are not followed. The pump operator, as well as individuals connecting supply or discharge hoses to the apparatus must be familiar with these pump operating instructions as well as other operating instructions and manuals for the apparatus, water hydraulics and component limitation.

General Description

Chain drive speed increasing transmission driven from a PTO on the vehicle. Furnished with a fire pump directly mounted (Models QA, QB, QC) or with an output shaft for driving remotely mounted fire pumps or other equipment (PTO models TQB and TQC).

The bearings and drive chain are lubricated by a splash and passive lubrication system. Lubrication is accomplished when spray from the chain in the top of the case. The lubricant flows out of the reservoir and onto the inside surface of the chain. This ensures all pivoting components of the chain receive lubrication.

Maintenance

NOTICE

Lubrication fluid temperature should not exceed 250 degrees F for extended periods of time.

Premature seal wear and damage will occur.

1. Check the lubrication fluid level monthly by checking the sight plug or by removing the oil level plug. The fluid should be level with the bottom of the oil level hole.
2. Change lubrication fluid and clean breather and magnetic drain plug annually or after each 100 hours of operation, whichever comes first. Lubrication fluid may be added through the oil level hole or by removing the breather and adding fluid through the opening.
3. Lubricant: Any type of automatic transmission fluid (ATF) may be used. For ambient temperatures over 90° F, SAE 20 oil 300 SSU @ 100° F with service classification SA, SB or SC should be used.

NOTICE

Low or excessive lubrication fluid may cause damage. If lubricant fluid level is low, locate source of leak and repair. If level is high, loosen oil level plug and drain until proper level is reached. If any water drains out, change lubrication fluid and determine source of water leakage and repair.

4. Quantity of lubrication fluid if system is completely drained and refilled:

Model	Mounting	Quantity
QA	All	1.50 Quarts .24 Liters
QB, TQB	All	4.50 Quarts 4.27 Liters
QC, TQC	Vertical, 22.5° from Vertical or 45° from Vertical	4.00 Quarts 3.80 Liters
	Interted	3.00 Quarts 2.80 Liters

5. See the next page for breather, oil fill, level and drain locations.

Breather, Oil Fill, Level and Drain Locations

Model QA

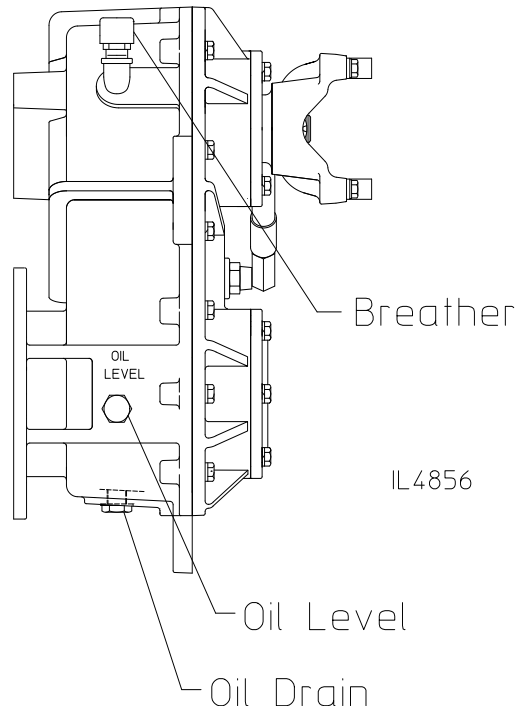

Models QB and TQB

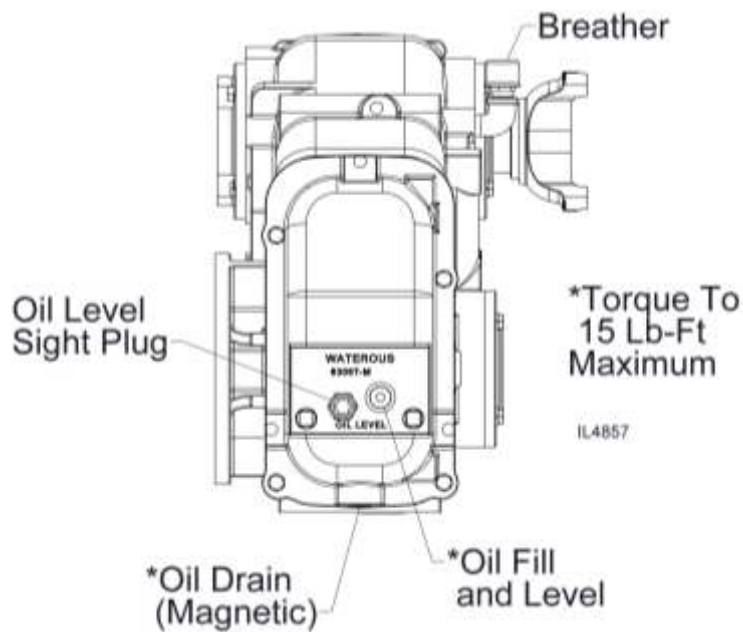

Breather, Oil Fill, Level and Drain Locations

Models QC and TQC

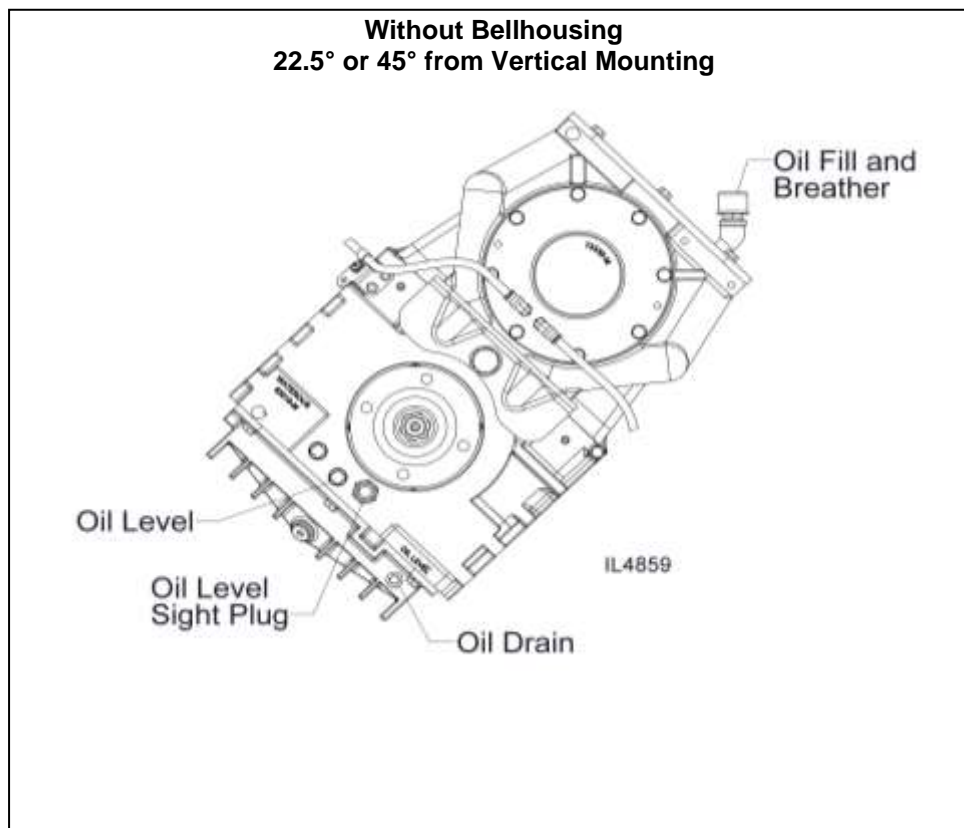
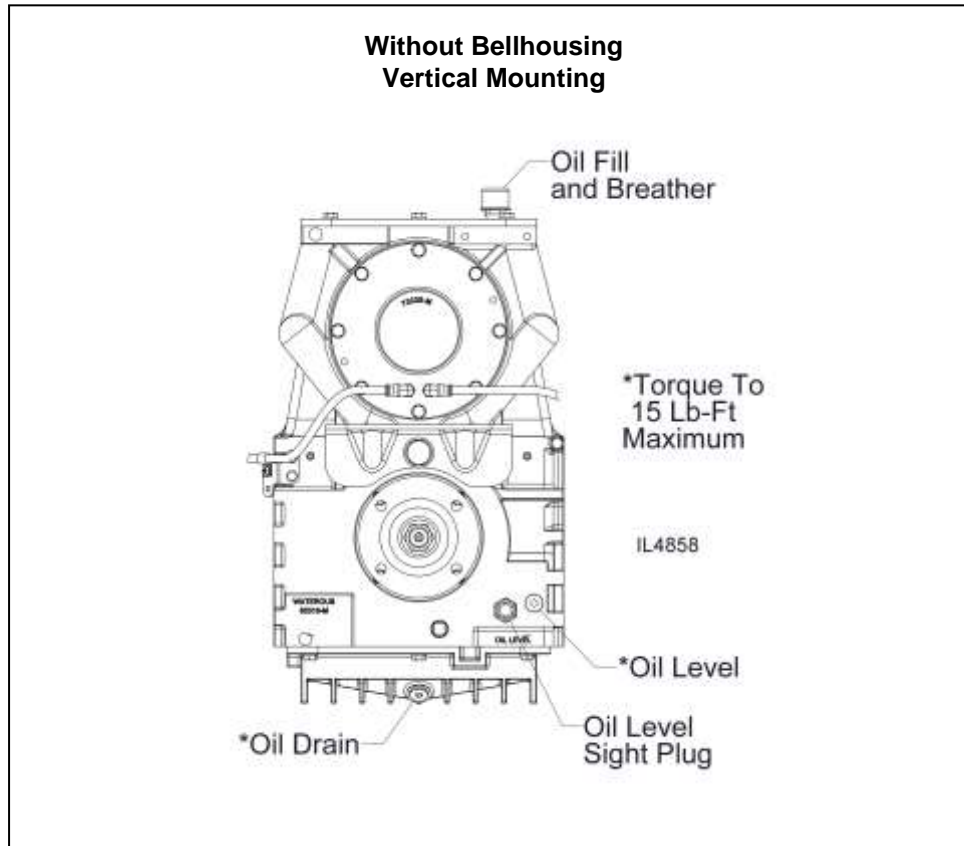

Breather, Oil Fill, Level and Drain Locations

Models QC and TQC (Cont'd)

