

IL1872

## Table of Contents

- Introduction .....2
- Ordering Repair Parts .....2
- Cross-Section View of QA Transmission and Pump.....2
- General Overhaul Information.....3
- Disassembly Index** .....4
- Reassembly Index** .....4

## ***Introduction***

This instruction provides the necessary steps to overhaul model QA chain drive transmission. Note that the instructions are divided into Disassembly and Reassembly sections.

## ***Ordering Repair Parts***

When ordering repair parts, furnish the reference number of the component (from Service Parts List) along with the Pump Model and serial number.

Refer to the Service Parts Lists furnished with your pump for identification of individual components.

## **Cross-Section View of QA Transmission and Fire Pump**

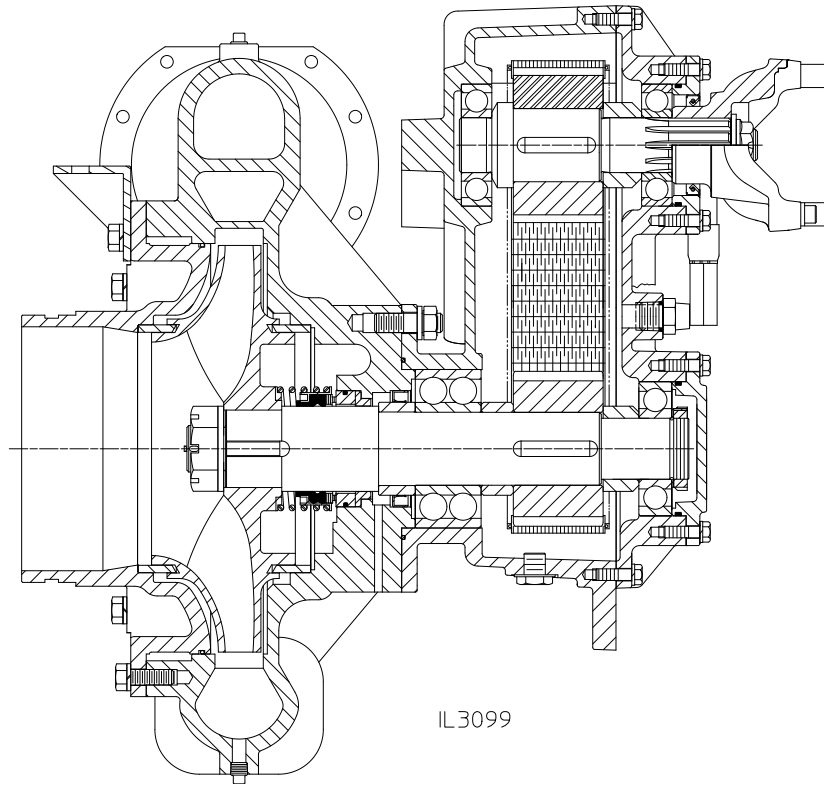

---

## General Overhaul Information

---

### ***Tools and Equipment***

The following tools and equipment are needed to overhaul a pump:

1. Usual automotive mechanic's hand tools.
2. An arbor press for assembling or disassembling components.
3. An engine lathe for turning impeller hubs.
4. A suitable hoist and slings.
5. Torque capability up to 325 lb-ft.

While no special tools and equipment are required, a few special items are illustrated or described so the mechanic can make them or they are available from the apparatus manufacturer or the Waterous Company. These special items are not absolutely necessary, but they will make the mechanic's work much easier.

### ***Preliminary Testing***

Before disassembling a pump, test it thoroughly, if possible, and record the results. A comparison of this test with periodic tests recommended in form F-1031, Section 1000 can often reveal specific pump troubles. Excessive speed, for instance, indicates that impellers and/or wear rings are probably worn.

### ***Cleaning***

The continued satisfactory operation of a pump depends to a great extent upon the cleanliness of its internal parts. Sand, dirt or other abrasive material will wear bearings, gears and related parts. Before disassembling a pump for repairs, be sure to clean its exterior. Make sure the working space, benches and tools are clean. Use only clean, lint-free cloths to wipe off components. Before reassembling a pump or its components, be sure to clean them thoroughly.

### ***Pump Bodies and Impellers***

Flush out these components and related parts with clean water. Use a stiff brush to remove loose scale, caked sediment, etc. Be sure to remove all

traces of old gaskets. Examine pump bodies, covers, adapters and fittings for cracks, severe corrosion or other damage. Almost all damage to these parts results from improper use or maintenance, or from freezing. Replace defective parts.

### ***Bearings, Gaskets, Seals and O-rings***

Parts of this nature are frequently damaged during removal or disassembly. In addition, they sometimes deteriorate or lose their effectiveness because of age or misuse. Replacing these parts whenever overhauling a pump is a good policy.

### ***Impeller Shafts***

Examine shaft for severe scratches, grooves or corrosion - especially under packing or mechanical seals. If scratches are not severe, and are not under packing and seals, clean them with a fine-cut file. Grooves are usually permissible if they are not sharp or too deep. Even slight longitudinal scratches will cause leaks and should be removed.

### ***Installing Ball Bearings***

Most Waterous pumps are designed so that ball bearings fit tightly on their shafts and have relatively loose fits in the bearing housings. When mounting these bearings on shafts, always apply force to the inner races. When bearings have a tight fit in the housings, and a heavy force is necessary to install them, be sure to apply force only to the outer bearing races. For either type of fit, applying force to the wrong bearing race may damage the balls and race.

### ***Transmission Case Gaskets***

To provide added sealing for gaskets between transmission halves, coat both sides of these gaskets with a suitable sealant. A compound such as Permatex Super 300 is recommended for this application. Be sure all traces of previous gaskets and sealant are removed before installing new gaskets.

**Disassembly Index:**

**Reassembly Index:**

**Remove Pump from Vehicle:**

- Drain Fluid from Transmission ..... 5
- Disconnect Driveline ..... 5
- Remove Pump from Vehicle ..... 5

**Remove Pump from Transmission:**

See Pump Overhaul Instructions

**Disassemble Transmission:**

- Remove End Yoke ..... 6
- Remove Bearing Cover and Oil Seal Housing ..... 7
- Remove Case Cover ..... 8
- Remove Drive and Impeller Shafts ..... 9
- Disassemble Drive Shaft ..... 10
- Disassembly Impeller Shaft ..... 10

**Inspection and Repair .....11, 12**

**Assemble Transmission:**

- Assemble Drive Shaft ..... 13
- Assemble Impeller Shaft ..... 13
- Install Impeller Shaft ..... 14
- Install Drive Shaft ..... 15
- Install Case Cover ..... 16
- Install Bearing Cover and Oil Seal Housing ..... 17
- Install End Yoke ..... 18

**Install Pump on Transmission:**

See Pump Overhaul Instructions

**Final Assembly Steps ..... 19**

**Lubrication ..... 19**

**Testing:**

- Hydrostatic ..... 20
- Operational ..... 20

## Disassembly

### Remove Pump From Vehicle

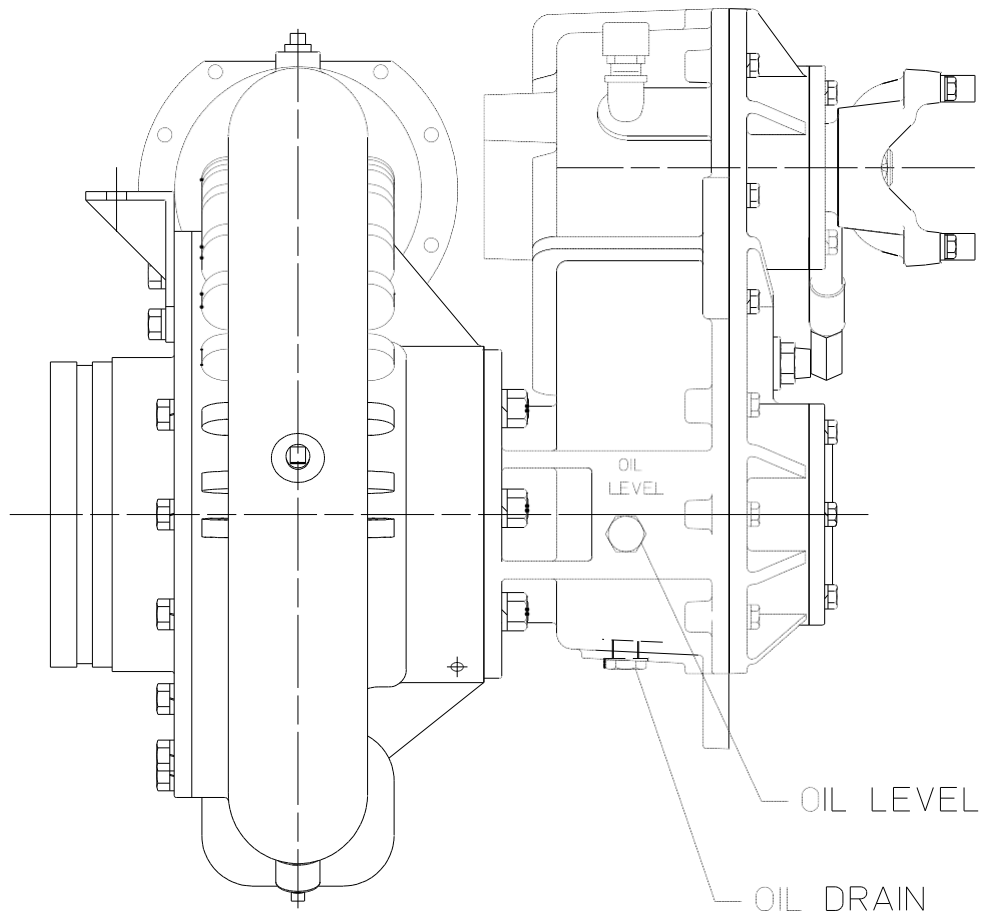

1. Drain fluid from transmission.
2. Disconnect propeller or drive shafts to pump transmission.
3. Disconnect pump intake and discharge piping.
4. Disconnect cooling and drain lines, electrical wiring and similar equipment from pump and accessories.

IL3626

## Disassembly

### Removal of End Yoke

1. Remove the cotter pin, shaft nut, or self-locking nut and washer from the drive shaft. Do not reuse self-locking nut. Apply lubricating oil to the threads before removing.
2. Slide the end yoke off the shaft.

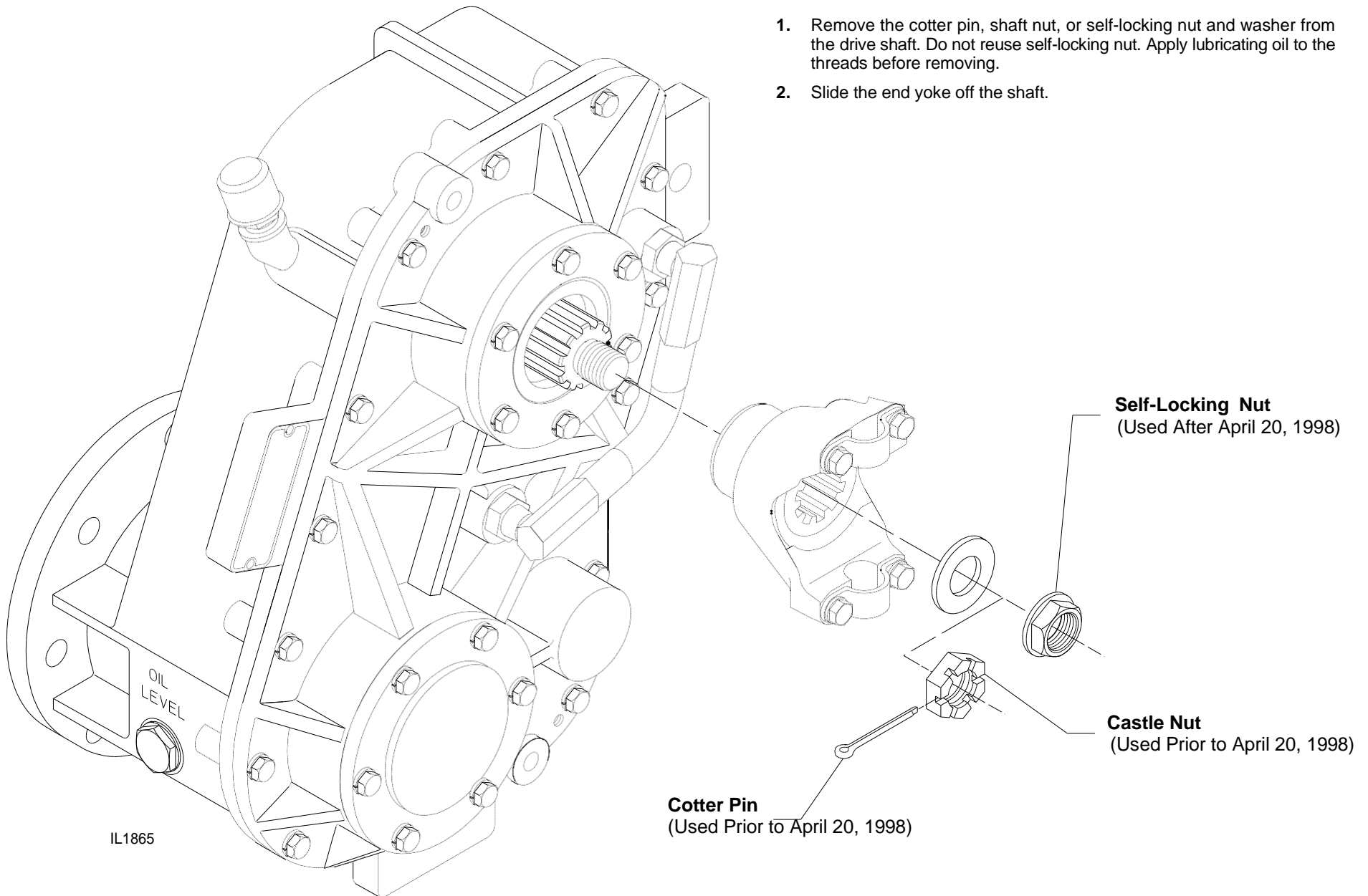

# Disassembly

## Removal of Bearing Cover and Oil Seal Housing

1. Remove the six (6) hex head screws from the bearing cover.
2. Remove the bearing cover and shims.
3. Remove the six (6) hex head screws from the oil seal housing.
4. Remove the the oil seal housing and shims.

**Note the number of shims that were removed with the oil seal housing and bearing cover for reassembly.**

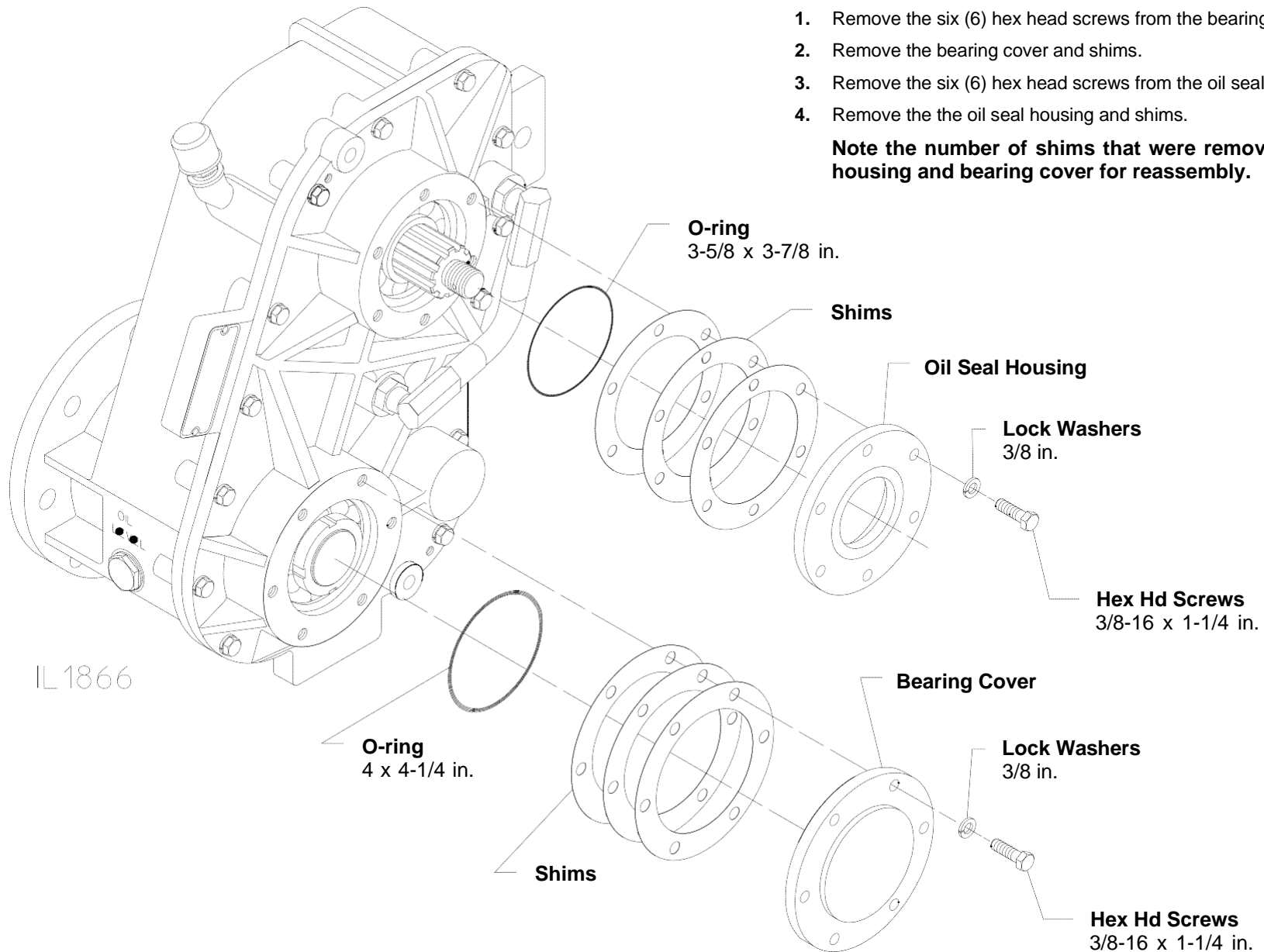

# Disassembly

## Removal of Case Assembly

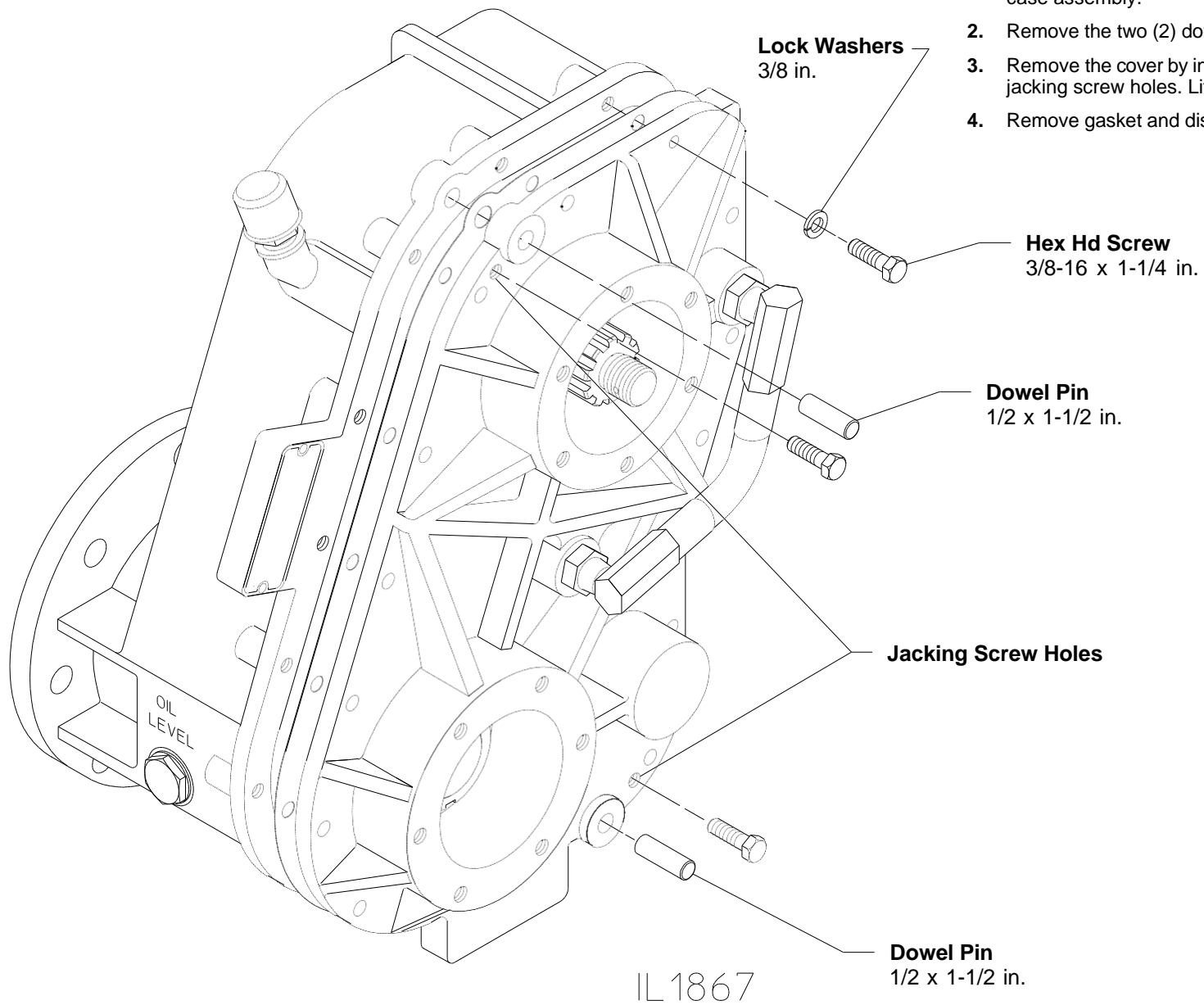

1. Remove the fifteen (15) hex head screws from the cover of the case assembly.
2. Remove the two (2) dowel pins.
3. Remove the cover by inserting hex head screws in the two (2) jacking screw holes. Lift cover off evenly.
4. Remove gasket and discard.

IL1867



## Disassembly

### Removal of Drive and Impeller Shafts

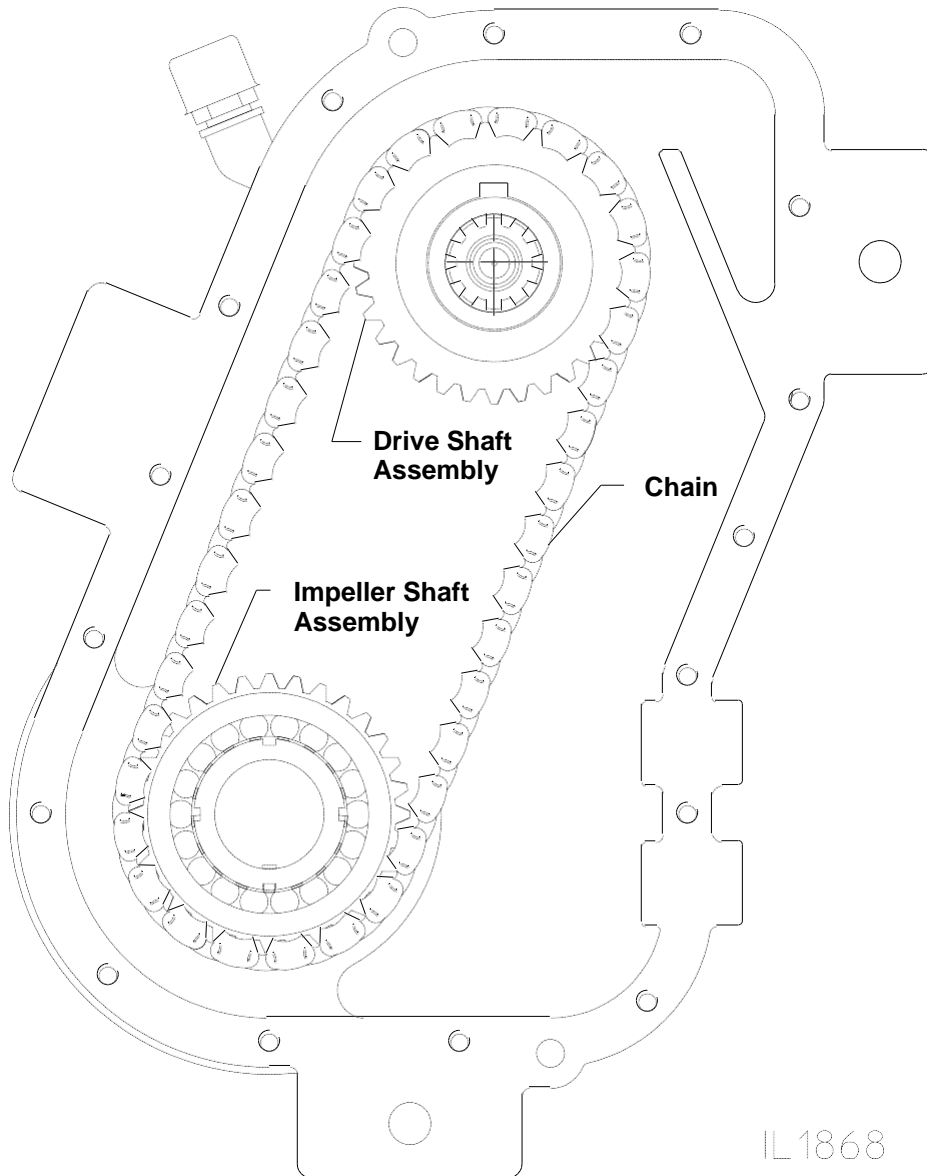

1. Lift the drive shaft assembly, impeller shaft assembly and chain up evenly until the drive shaft assembly clears the bore.
2. Remove the drive shaft assembly and chain.
3. Remove the impeller shaft assembly.

**NOTE: Take care not to scratch the oil seal sleeve or mechanical seal journal on the impeller shaft.**

IL1868

## Disassembly

### Disassembly Sprocket and Bearings - Drive Shaft

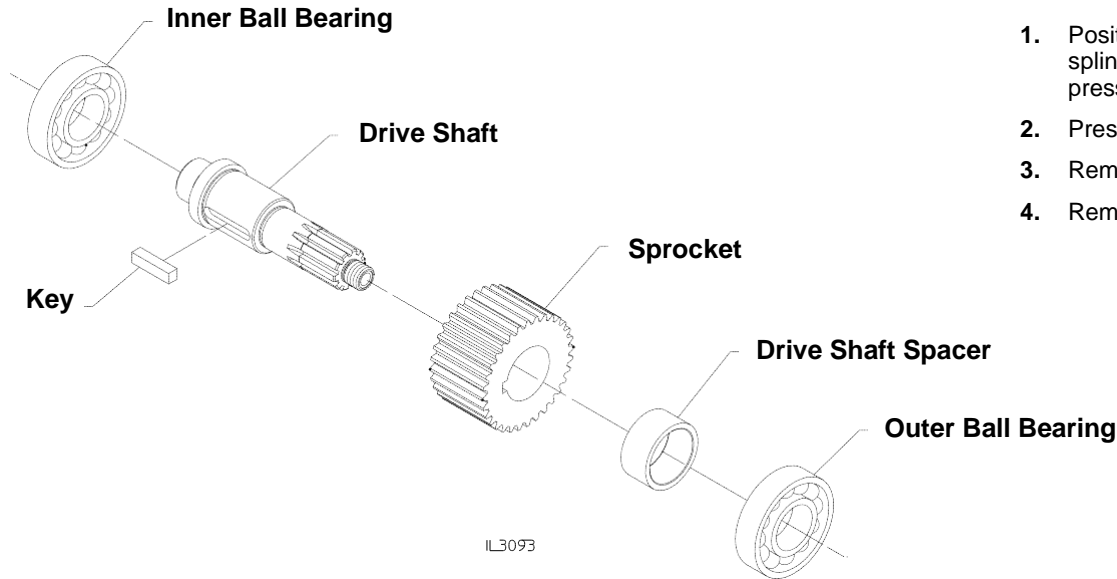

1. Position the drive shaft assembly in a vertical position in a press with the spline end of the shaft up and the sprocket supported by the table of the press.
2. Press the shaft out of the sprocket, drive shaft spacer and outer ball bearing.
3. Remove key from the drive shaft.
4. Remove the inner ball bearing from the drive shaft.

### Disassembly Sprocket and Bearings - Impeller Shaft

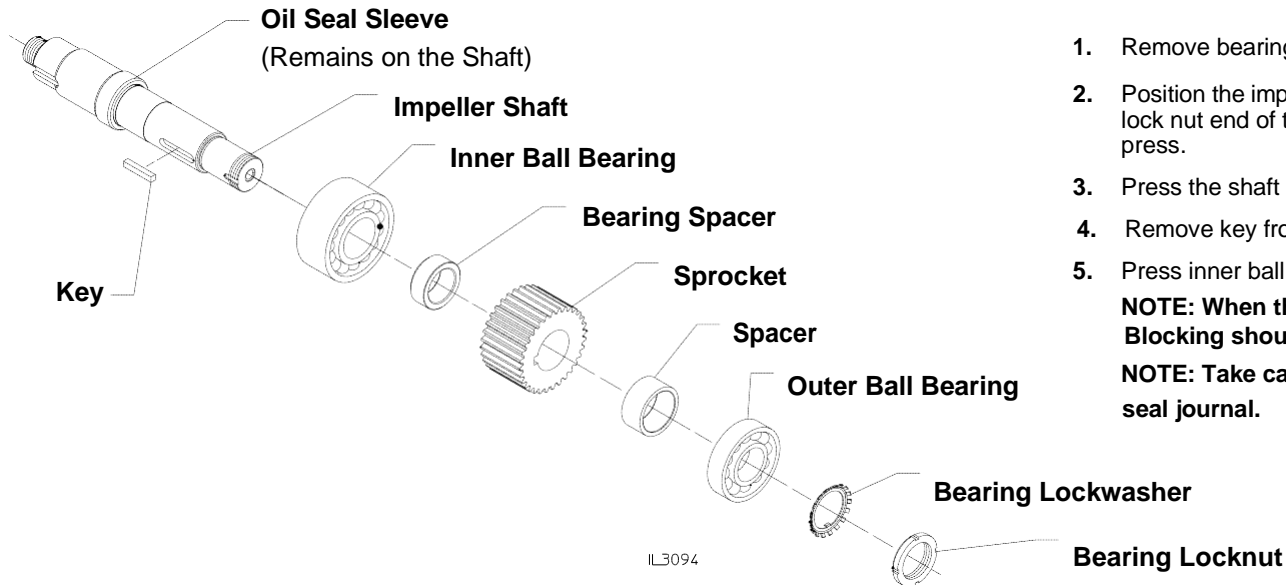

1. Remove bearing lock nut and bearing lockwasher.
  2. Position the impeller shaft assembly in a vertical position in a press with the lock nut end of the shaft up and the sprocket supported by the table of the press.
  3. Press the shaft out of the bearing, sprocket and spacers.
  4. Remove key from the impeller shaft. Remove bearing spacer.
  5. Press inner ball bearing off the shaft.
- NOTE: When the shaft is free of the inner ball bearing, it will fall free. Blocking should be provided under the shaft.**
- NOTE: Take care not to scratch the oil seal sleeve or mechanical seal journal.**

## Reassembly

### Inspection and Repair

#### ***Ball Bearings***

When cleaning bearings, bearing manufacturers recommend placing them in a basket and suspending the basket in a container of solvent, preferably overnight. Avoid rotating the bearings before solid particles are removed, to prevent damaging races and balls.

After cleaning, spin them immediately in light oil and check each one as described below:

1. Examine bearing for rusted or pitted balls, races or cages.
2. Check cage and races for cracks or other damage. Examine balls and races for brinelling, abrasion and serious discoloration. If in doubt about condition of bearing, replace it.
3. Rotate bearing slowly, and check for roughness or excessive internal looseness. If a rough spot is found, it may be dirt caked on a race. Try cleaning it again. If endplay is doubtful, compare it with a new bearing. If the bearings are not to be installed right away, wrap them in clean, oil proof paper.

## Reassembly

### Inspection and Repair (Continued)

#### ***Impeller Shaft***

Examine shaft for signs of severe scratches, grooves or corrosion, especially under the oil seal or mechanical seals. If scratches are not severe, and are not under seals, they can be ignored. Check for cracks, pitting, twisted splines or damaged keyway.

Scratches in the area of the bellows of the mechanical seal can possibly be removed by spinning the shaft in a lathe and polishing with a fine emery cloth. The journal for the oil seal may be similarly cleaned, however, spiral type polishing may lead to oil leaks.

#### ***Installing Oil Seals***

Before installing an oil seal in a housing, be sure that the seal, shaft and housing are clean.

Apply force to the outer edge of the seal and press in evenly.

#### ***Oil Seal Sleeve***

Check for wear and scratches where the seal contacts the sleeve. The journal may be polished with a fine emery cloth, however; any polishing that leaves a spiral pattern may lead to an oil leak. If a groove has been worn in the sleeve, it can be reused by turning it end for end.

If questionable, replace the sleeve or fit with a thin replacement sleeve. This replacement sleeve allows use of the same size oil seal. This type of repair sleeve is available through most sources of oil seals.

#### ***Volute Body and Intake Adapter***

Examine for cracks, severe corrosion or other damage. Almost all damage to these parts results from improper use or maintenance, or from freezing. Replace defective parts.

Clean out drainage hole in volute body, located between the seat for the throttle bushing and oil seal.

#### ***Throttle Bushing***

Note: The bushing serves as a restriction to fluid leakage if the mechanical seal fails.

Examine the bore in the bushing for wear due to contact with the shaft. The size of the bore is 2.760/2.762.

## Reassembly

### Reassembly Sprocket and Bearings - Drive Shaft

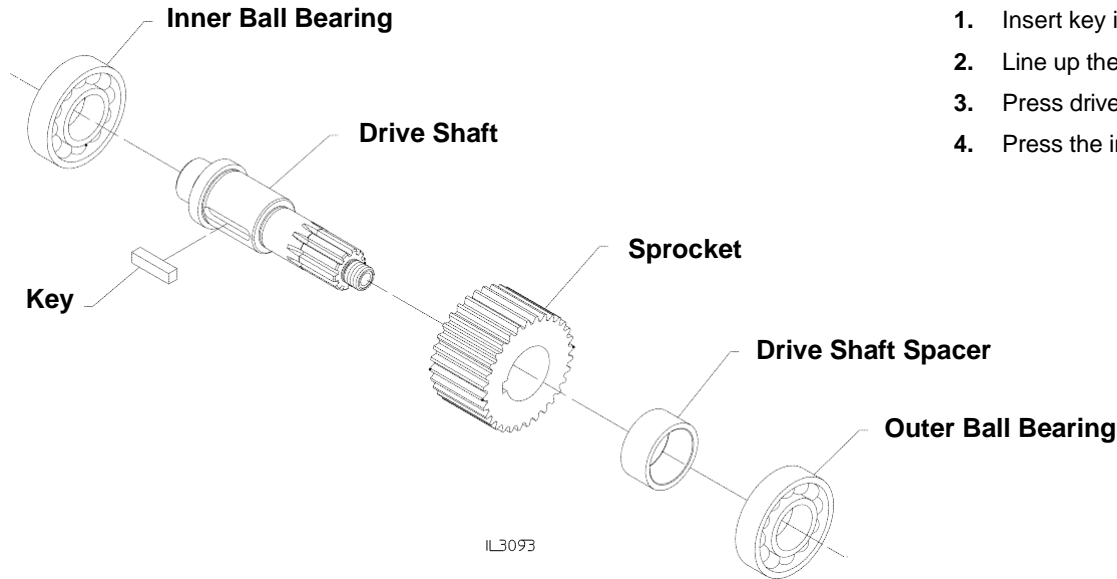

1. Insert key into keyway in the drive shaft.
2. Line up the keyway in the sprocket with the key in the drive shaft.
3. Press drive shaft into the sprocket, drive shaft spacer and outer ball bearing.
4. Press the inner ball bearing onto the drive shaft.

### Reassembly Sprocket and Bearings - Impeller Shaft

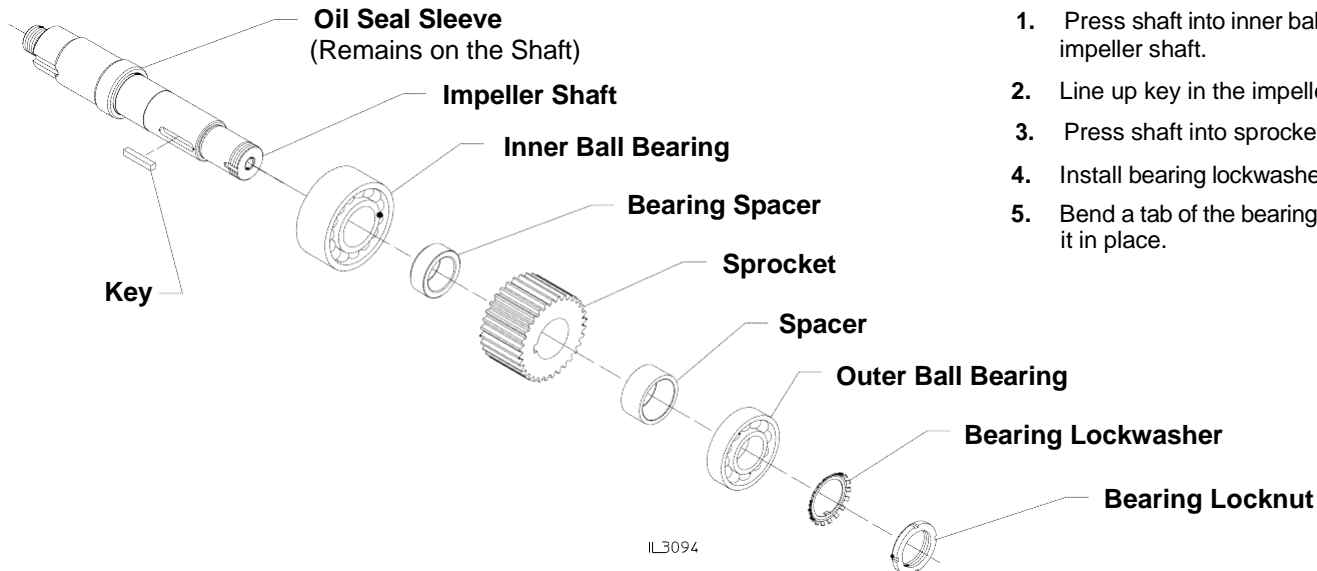

1. Press shaft into inner ball bearing and spacer. Install key into the keyway in the impeller shaft.
2. Line up key in the impeller shaft with keyway in the sprocket.
3. Press shaft into sprocket, shaft spacer and outer ball bearing.
4. Install bearing lockwasher and bearing lock nut on shaft and secure. 1/4 TFFT.
5. Bend a tab of the bearing lockwasher into a slot in the bearing lock nut to secure it in place.

# Reassembly

## Installing Impeller Shaft Assembly

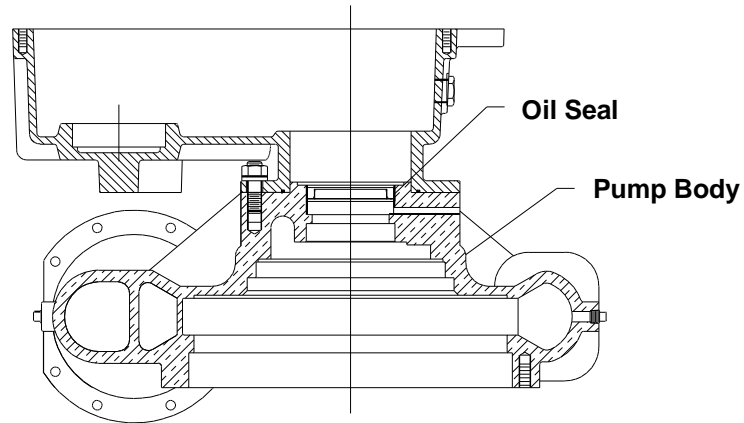

**Step 1**

1. Install oil seal in pump body. Make sure the lip of the seal is facing towards the transmission.
2. Add blocking as shown and lower impeller shaft assembly into the bore of the transmission until the top of the sprocket is approximately 1/2" higher than the top of the case (see side view - cutaway below). Note that care must be taken not to damage the oil seal in the pump body.
3. Place the chain around the impeller shaft sprocket as shown in the diagram below.

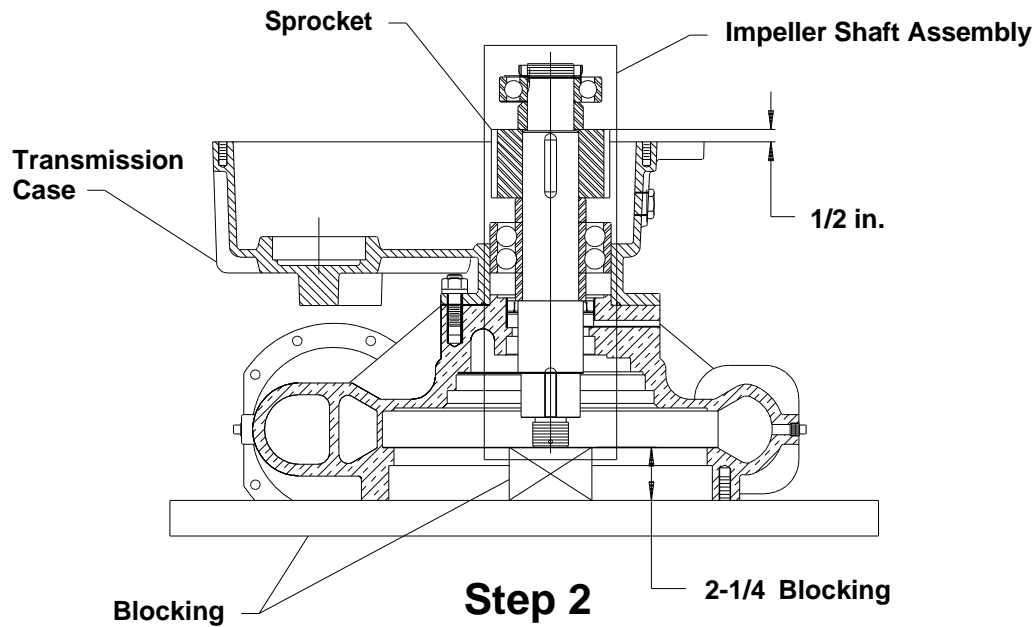

**Step 2**

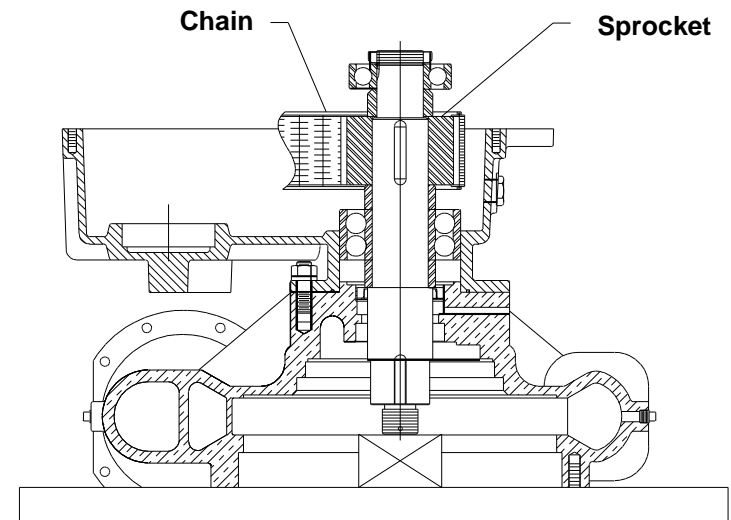

**Step 3**

IL1832

# Reassembly

## Installing Drive Shaft Assembly

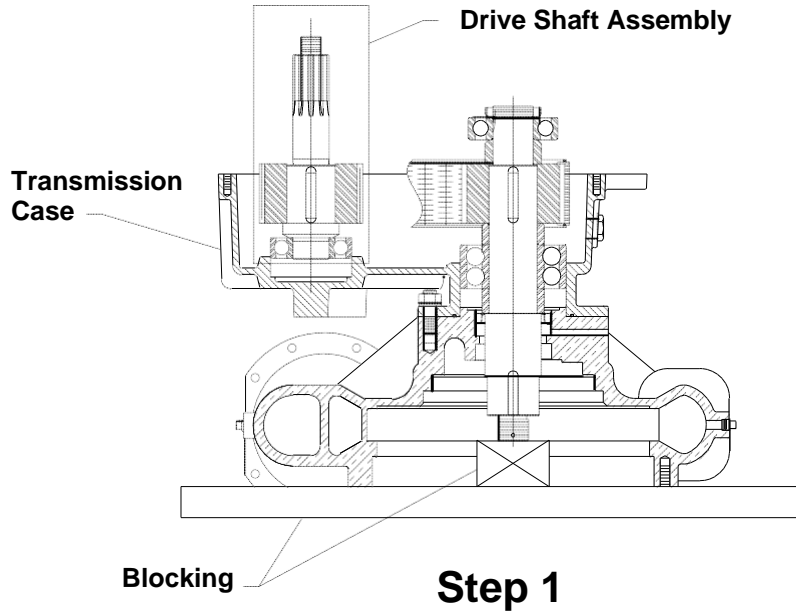

1. Lower the drive shaft assembly into the transmission.
2. Wrap the chain around the sprocket.
3. Remove blocking and then lower both the drive shaft assembly and the impeller shaft assembly into their bores simultaneously (note that this may require two people to perform this task).

NOTE: Care must be taken not to damage the oil seal in the pump body.

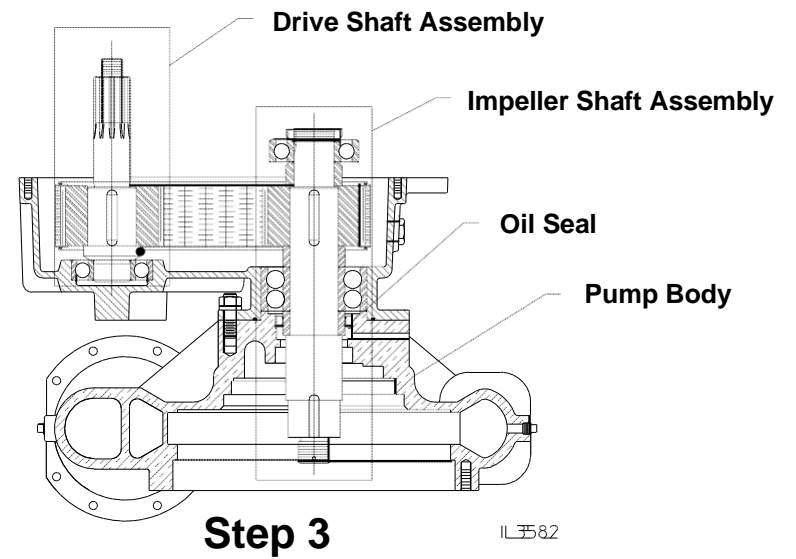
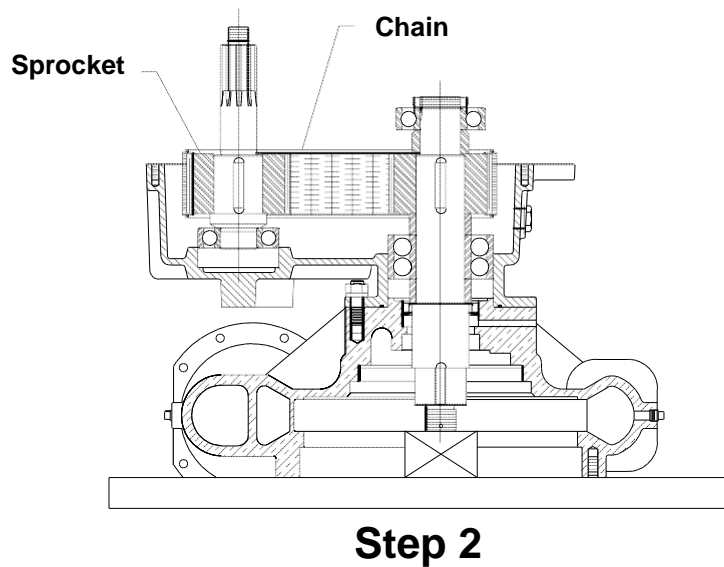

## Reassembly

### Install the Case Assembly Cover

1. Place a new gasket between the case and cover.
2. Lower the case assembly cover onto the case.
3. Tap in the two (2) dowel pins.
4. Secure the cover by inserting and tightening the fifteen (15) hex head bolts.

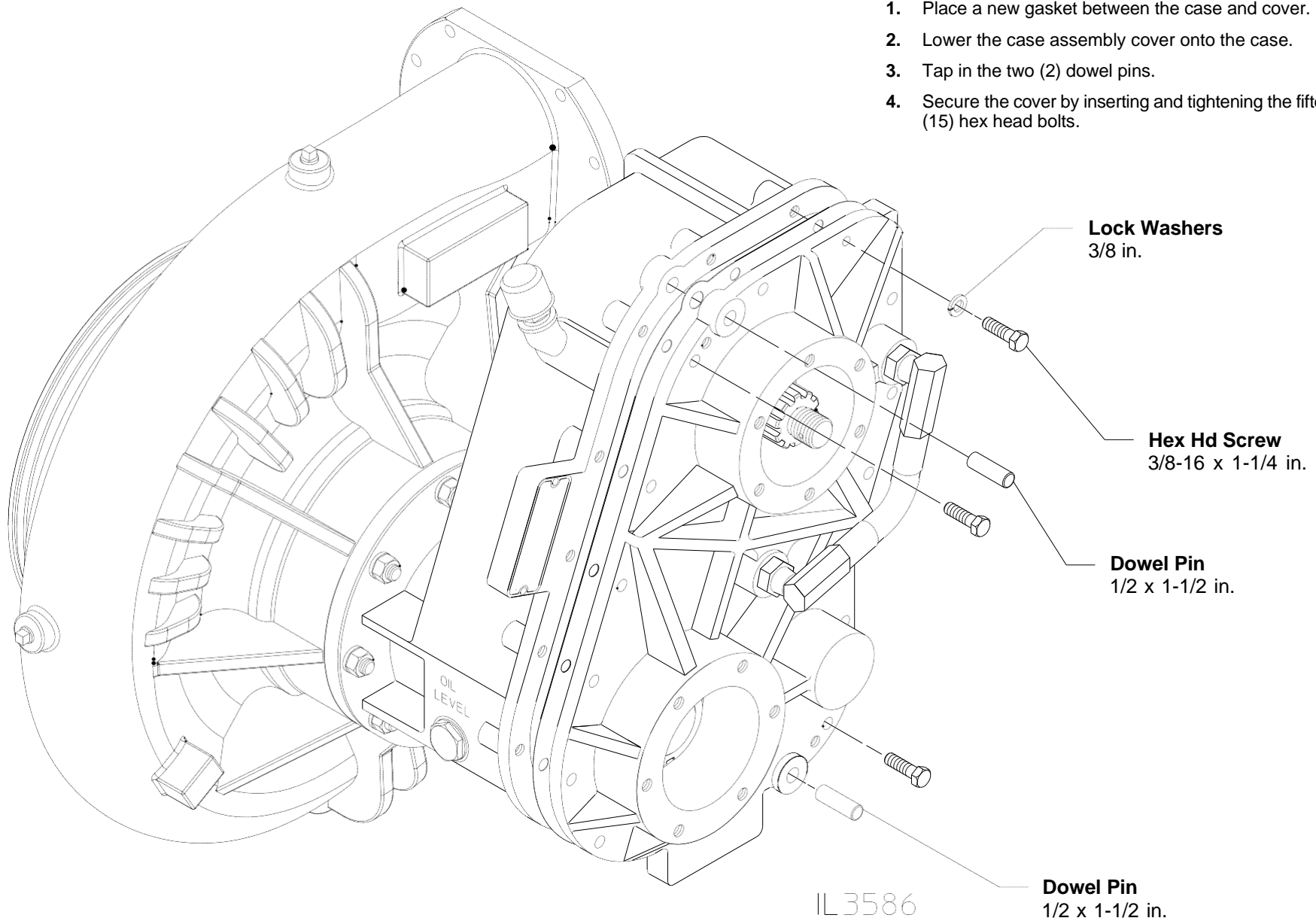



# Reassembly

## Installing Bearing Cover and Oil Seal Housing

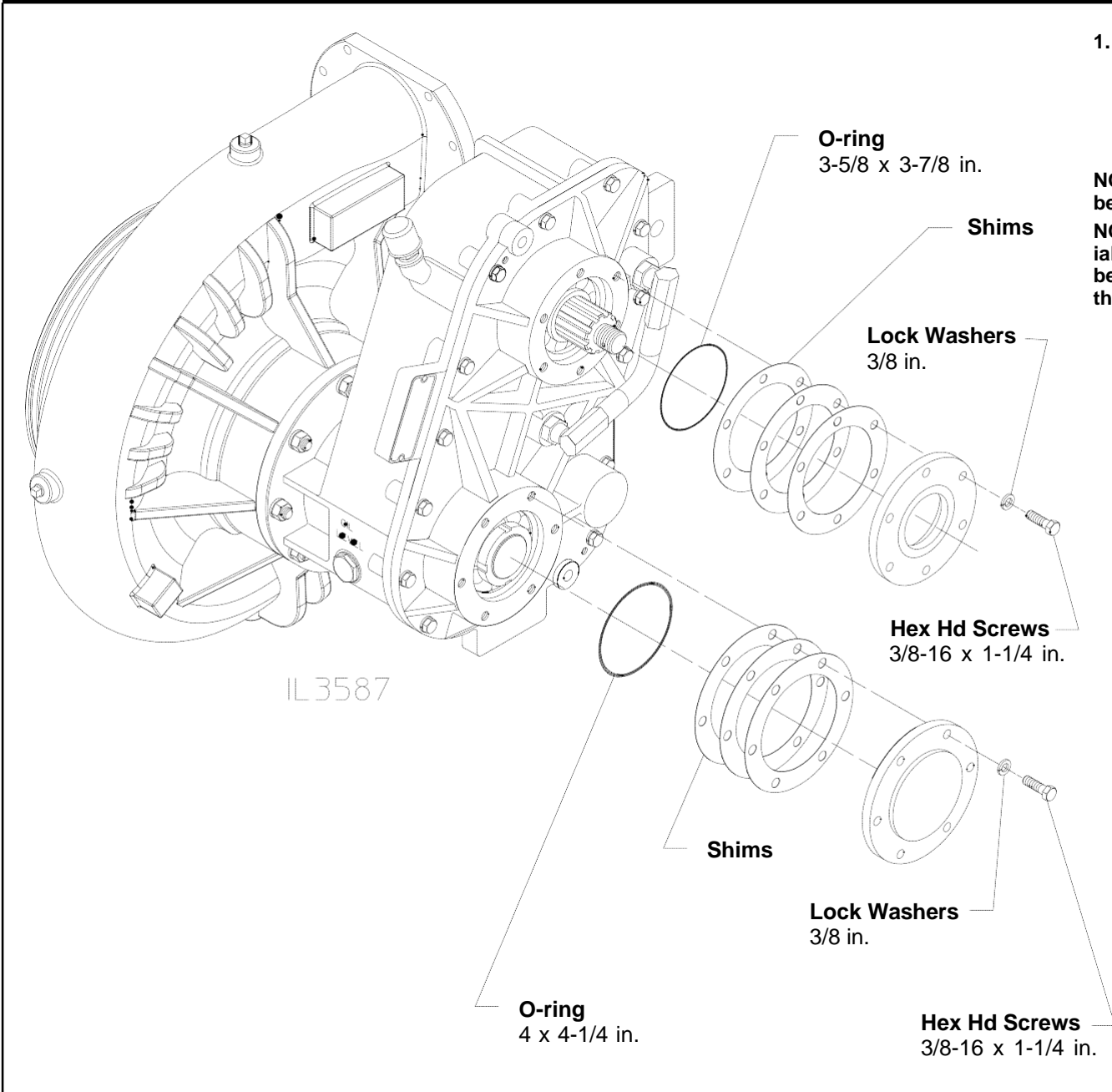

1. Before installing oil seal in the seal housing, coat the seal outer diameter evenly with sealant (Loctite Ultra Blue RTV Silicon Sealant). Be sure that the seal, shaft and seal housing are clean. Always install a seal with the seal lip facing in. Apply force to the outer edge of the seal and press in evenly.

**NOTE: The pump must be attached to the transmission before the impeller shaft can be shimmed.**

**NOTE: The shafts were factory shimmed to limit the axial float to 0.005 - 0.010. If any of the drive line parts have been changed, it may be necessary to change the total thickness of shims. Perform the following:**

2. Hold the bearing cover or oil seal housing in position against the transmission case without an O-ring and measure the gap between the face of the cover/housing and transmission case with a feeler gage in several places. This gap thickness plus .005" is the minimum amount of shims to select.
3. Remove bearing cover or oil seal housing and install a new O-ring. Reinstall with shims between the face of the cover/housing and the transmission case. Install and tighten screws.
4. Check to assure that axial float exists either with an indicator or by feel. If in doubt, add an additional .5 " shim. No harm will result from a small amount of additional axial float, but bearing life will be shortened if bearings are excessively pre-loaded.

**NOTE: The shims are color coded for thickness as follows:**

Blue .....	.005"
Aluminum .....	.007"
Brown .....	.010"

# Reassembly

## Installing the End Yoke

1. Install oil seal.
2. Slide the end yoke on the shaft. Note that care must be taken not to damage the oil seal.
3. Install the cotter pin, shaft nut, or self-locking nut and washer onto the drive shaft. Apply lubricating oil to the threads before installing.

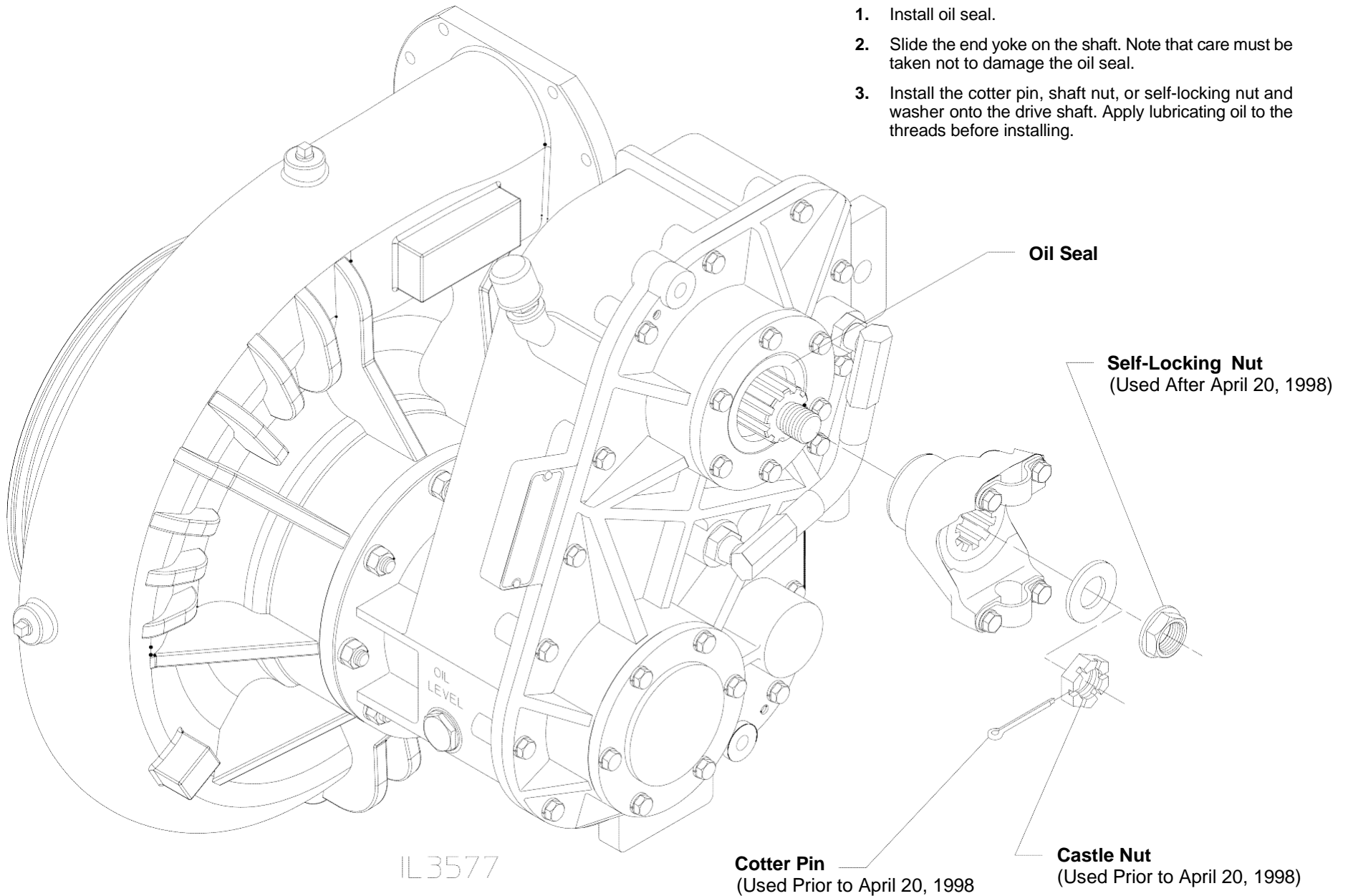

## Lubrication

Fill transmission with lubricant specified on Q series transmission operation and maintenance instructions.

## Final Assembly

1. Check all fasteners for tightness.
2. Install pump in vehicle.
3. Connect propeller or drive shafts to pump transmission.
4. Connect pump intake and discharge piping.
5. Connect cooling and drain lines, electrical wiring and similar equipment from pump and accessories.
6. Fill transmission with lubricant. See Lubrication.

## Testing

Before a pump is returned to service, it is advisable to give it both hydrostatic and operational tests to check it for leaks and to make sure the pump operates properly.

### ***Hydrostatic Testing***

1. Connect pump to a hydrant or other pressurized water supply.
2. Close all drain lines and open discharge and priming valves.
3. Open hydrant until water runs out through discharge valves and discharge pipe in priming pump. Close all valves. Be sure to evacuate all air from pump.
4. Apply water pressure to pump for 15 minutes. Do not exceed 350 psi (24.2). With a portable light, check pump for leaks. If leaks are discovered, tighten connections or attaching parts as necessary.

Note: If a mechanical seal is used, it may leak under hydrostatic pressure. However, it should stop leaking after the seal faces are run-in during operation testing.

5. After all leaks are eliminated, shut hydrant valve, drain pump completely and disconnect intake hose.

### ***Operational Testing***

1. Operate pump at its maximum intended service pressure. Do not exceed 350 psi (24.2 bar) (450 psi, 31 bar with positive intake).
2. With a portable light, check pump for leaks. If leaks are discovered, stop pump and tighten connections or attaching parts as necessary. Repeat until all leaks are eliminated.
3. While pump is running, check for unusual noises, oil leaks, overheated bearings, etc. If anything unusual is discovered, stop pump immediately and determine the cause.