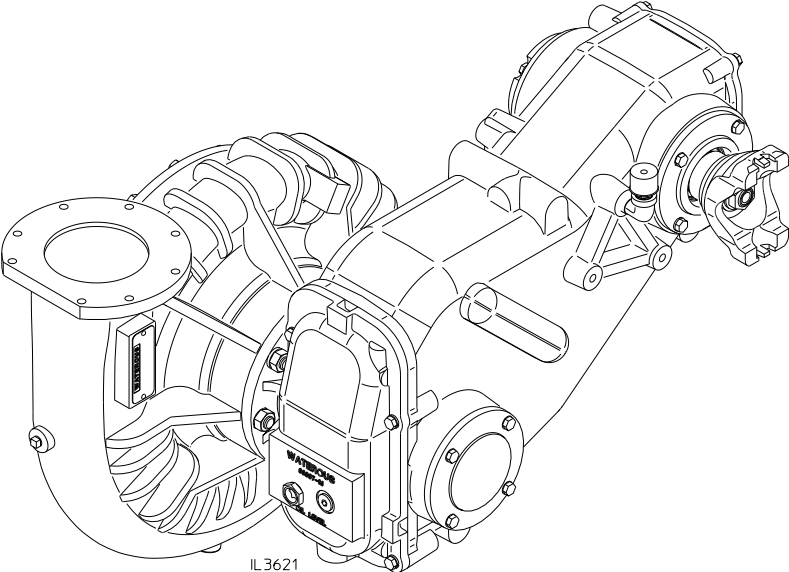

Table of Contents



- Introduction 2
- Ordering Repair Parts 2
- Cross-Section View of QB Transmission and Pump..... 2
- General Overhaul Information..... 3
- Disassembly Index 4
- Reassembly Index..... 4



Read through the safety information and overhaul instructions carefully before repairing your Waterous CRQB Series Fire Pump.

NOTE: Instructions subject to change without notice

Introduction

This instruction provides the necessary steps to overhaul QB chain drive transmissions. Note that the instructions are divided into Disassembly and Reassembly sections.

Ordering Repair Parts

When ordering repair parts, furnish the reference number of the component (from Service Parts List) along with the Pump Model (CRQB) and serial number. Refer to the Service Parts Lists furnished with your pump for identification of individual components.

Cross-Section View of Model QB Transmission with Fire Pump

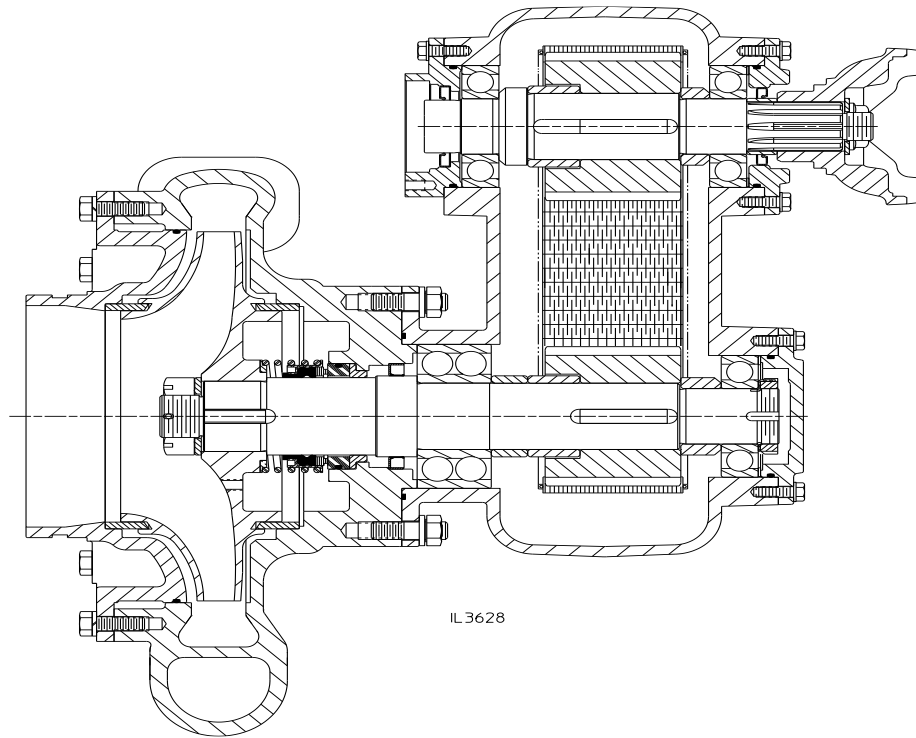

General Overhaul Information

Tools and Equipment

The following tools and equipment are needed to overhaul a pump:

1. Usual automotive mechanic's hand tools.
2. An arbor press for assembling or disassembling components.
3. An engine lathe for turning impeller hubs.
4. A suitable hoist and slings.
5. Torque capability up to 300 lb-ft.

While no special tools and equipment are required, a few special items are illustrated or described so the mechanic can make them. They are also available from the apparatus manufacturer or the Waterous Company. These special items are not absolutely necessary, but they will make the mechanic's work much easier.

Preliminary Testing

Before disassembling a pump, test it thoroughly, if possible, and record the results. A comparison of this test with the periodic tests recommended in form F-1031, Section 1000 can often reveal specific pump troubles. Excessive speed, for instance, indicates that impellers and/or wear rings are probably worn.

Cleaning

The continued satisfactory operation of a pump depends to a great extent upon the cleanliness of its internal parts. Sand, dirt or other abrasive material will wear bearings, gears and related parts. Before disassembling a pump for repairs, be sure to clean its exterior. Make sure the working space, benches and tools are clean. Use only clean, lint-free cloths to wipe off components. Before reassembling a pump or its components, be sure to clean them thoroughly.

Pump Bodies and Impellers

Flush out these components and related parts with clean water. Use a stiff brush to remove loose scale, caked sediment, etc. Be sure to remove all

traces of old gaskets. Examine pump bodies, covers, adapters and fittings for cracks, severe corrosion or other damage. Almost all damage to these parts results from improper use or maintenance, or from freezing. Replace defective parts.

Bearings, Gaskets, Seals and O-rings

Parts of this nature are frequently damaged during removal or disassembly. In addition, they sometimes deteriorate or lose their effectiveness because of age or misuse. Replacing these parts whenever overhauling a pump is a good policy.

Impeller Shafts

Examine shaft for severe scratches, grooves or corrosion - especially under seals. If scratches are not severe, and are not under packing and seals, clean them with a fine-cut file. Grooves are usually permissible if they are not sharp or too deep. Slight longitudinal scratches will cause leaks and should be removed.

Installing Ball Bearings

Most Waterous pumps are designed so that ball bearings fit tightly on their shafts and have relatively loose fits in the bearing housings. When mounting these bearings on shafts, always apply force to the inner races. When bearings have a tight fit in the housings, and a heavy force is necessary to install them, be sure to apply force only to the outer bearing races. For either type of fit, applying force to the wrong bearing race may damage the balls and race.

Installing Oil Seals

Before installing an oil seal in a housing, be sure that the seal, shaft and housing are clean.

Apply force to the outer edge of the seal and press in evenly.

Disassembly Index:**Remove Pump from Vehicle:**

Drain Fluid from Transmission	5
Remove Pump from Vehicle	5

Remove Pump from Transmission:

See Pump Overhaul Instructions

Remove Chain:

Remove Case Covers.....	6
Disconnect and Remove Chain	7

Remove Impeller Shaft:

Remove Impeller Shaft from Case.....	8
--------------------------------------	---

Remove Drive Shaft:

Remove End Yoke and Hydraulic Adapter	9
Remove Drive Shaft from Case	10

Disassemble Shaft:

Impeller Shaft.....	11
Drive Shaft.....	12

Reassembly Index:

Inspection and Repair	13-14
------------------------------------	-------

Assemble Shafts:

Assemble Drive Shaft	15
Assemble Impeller Shaft	16

Install Drive Shaft:

Install Bearing in Case	17
Install Drive Shaft in Case	18
Adjust Position of Shaft	18
Install Oil Seal Housing and End Yoke	19
Install Hydraulic Adapter	19

Install Impeller Shaft:

Install Impeller Shaft in Case	20
Install Bearing Cover	20

Install Chain:

Install Chain in Case	21
Connect Chain	22-23
Install Case Covers	24

Install Pump on Transmission:

Install Oil Seal in Pump Body	25
Install Pump Body on Transmission	25

Assemble Pump:

See Pump Overhaul Instructions

Final Assembly Steps	26
-----------------------------------	----

Lubrication	26
--------------------------	----

Testing:

Hydrostatic	27
Operational	27

Disassembly - Remove Pump from Vehicle

Drain Fluid from Transmission

1. Remove drain plug from transmission pan. Transmission holds approximately 4.5 quarts (4.25 liters) of lubricant.

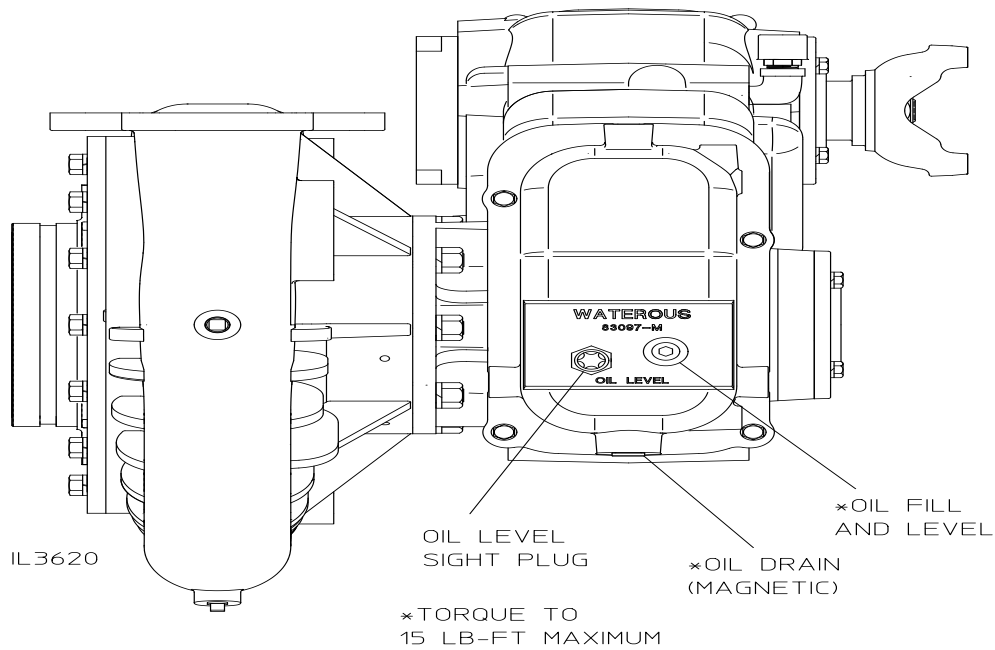

Remove Pump

1. Disconnect driveline, intake piping, discharge piping, drain lines and any accessory equipment connections.
2. Remove the fasteners attaching pump to the vehicle frame.
3. Lift the pump out of the vehicle.

Disassembly - Remove Chain

Remove Case Covers

1. Remove the transmission case covers as shown to access the chain.

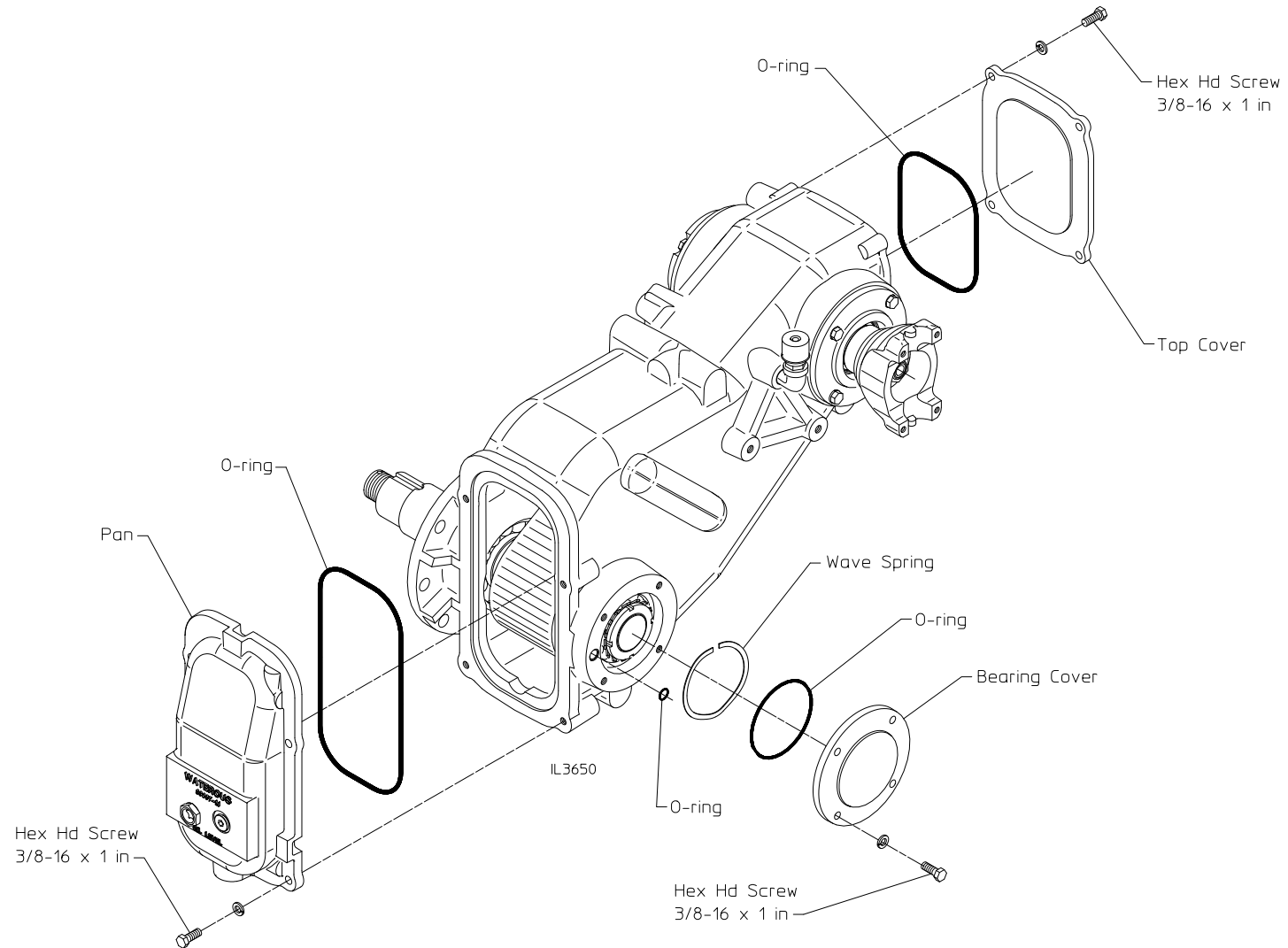

Disconnect and Remove Chain

- As viewed from the oil pan end of the transmission, rotate the shaft until the chain connecting pin is located (chain link with spirol pins on each side of the chain).
- Align the connecting pin with the access hole in the side of the case.
- Remove one spirol pin from the connecting pin. Note that the spirol pin indicated must be removed as the pin must be extracted through the access hole in the case.
- Push the connecting pin into the chain towards the access hole as indicated.
- With a needle nose pliers, reach into the access hole, grasp the pin and remove. Note that the connecting pin consists of two pieces.
- Separate the ends of the chain and remove from the transmission.

Step 2

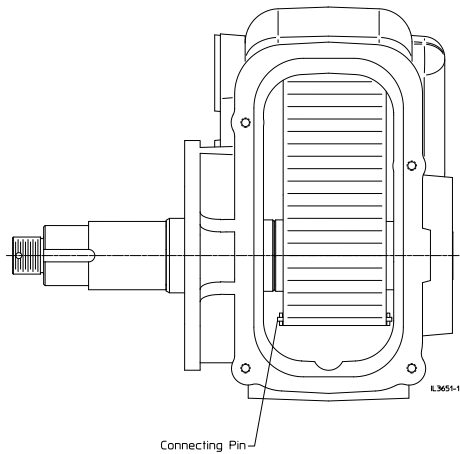

Step 3

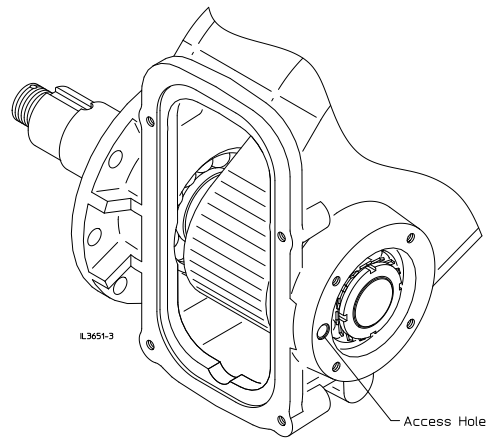

Step 4

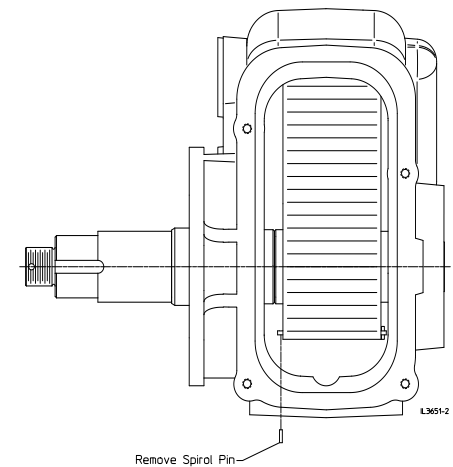

Step 5

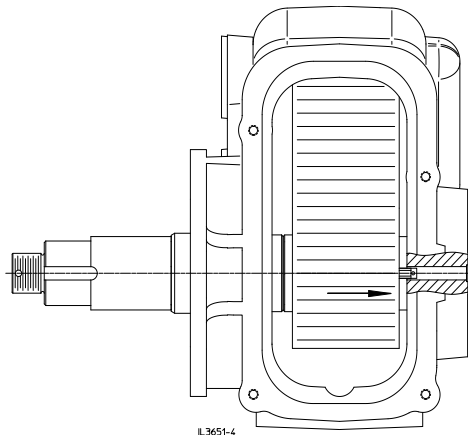

Step 6

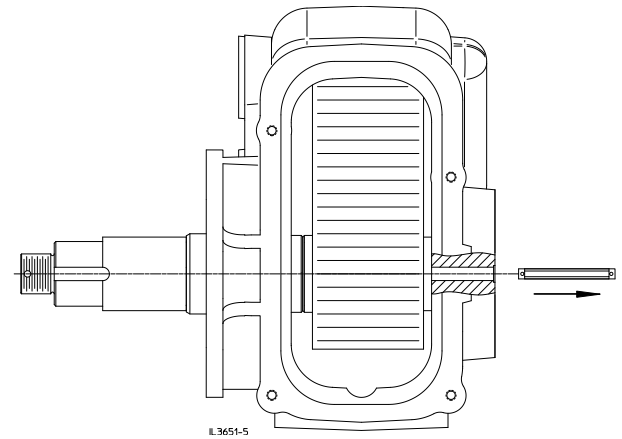

Disassembly - Remove Impeller Shaft

Remove Impeller Shaft from Case

1. With the transmission resting on the pump mounting flange, press the impeller shaft down and out of the case.

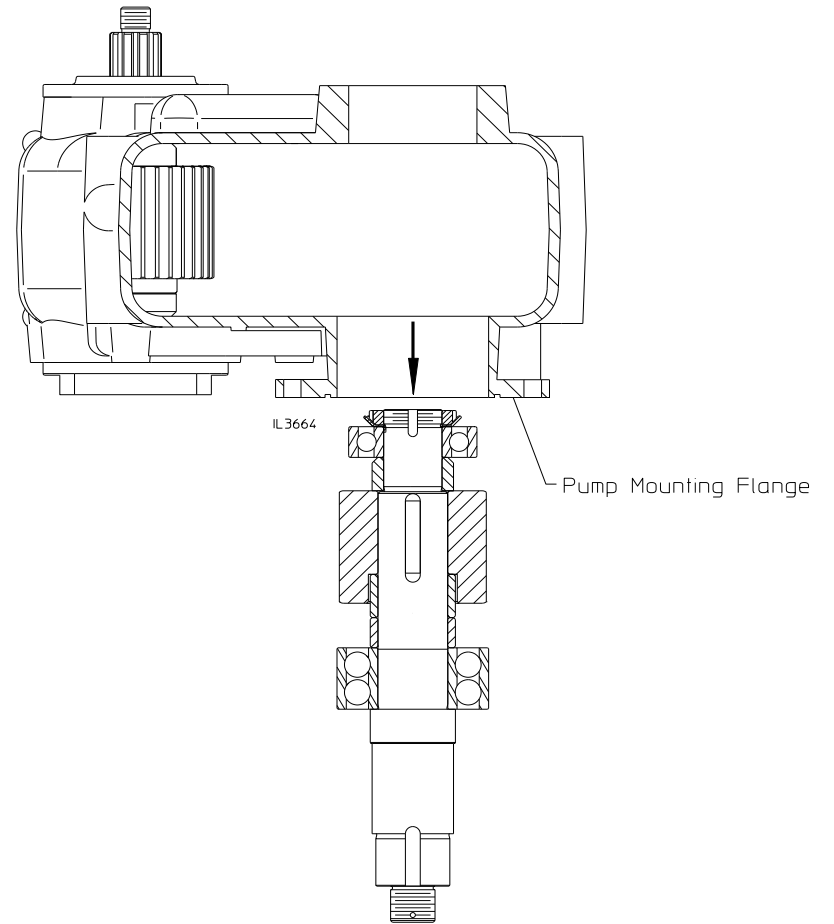
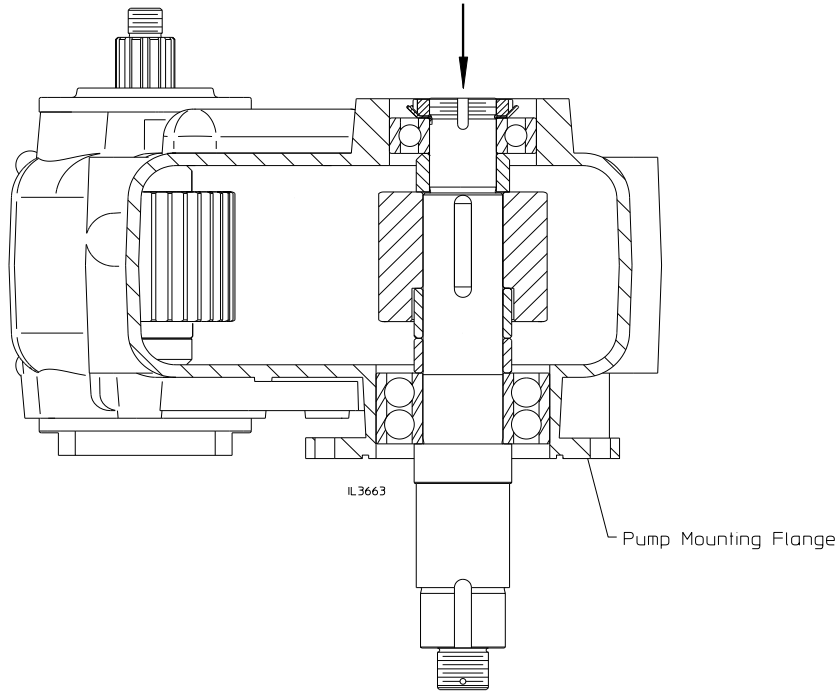

Disassembly - Remove Drive Shaft

Remove End Yoke and Hydraulic Adapter

1. Remove the hydraulic pump, hydraulic adapter and end yoke from the drive shaft.
2. Remove and discard oil seals and O-rings.

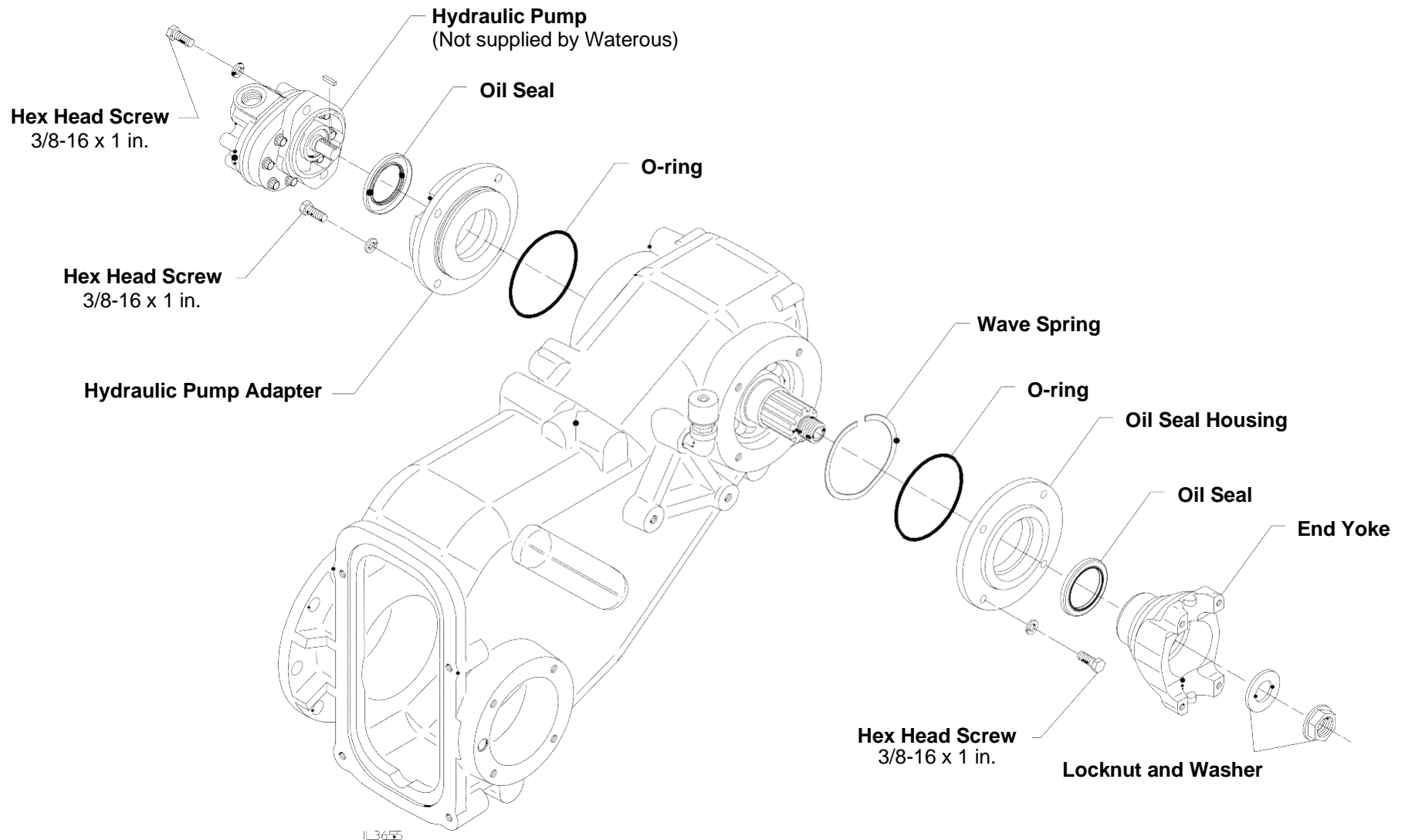

Remove Drive Shaft from Case

1. With the transmission case resting on the pump mounting flange side, press the drive shaft down until the drive sprocket contacts the inside wall of the case.
2. Continue to press the shaft down and out of the case. Note that the drive sprocket, spacer, bearing and oil seal sleeve will remain in the case.
3. Remove the drive sprocket, spacer, bearing and oil seal sleeve from the case.

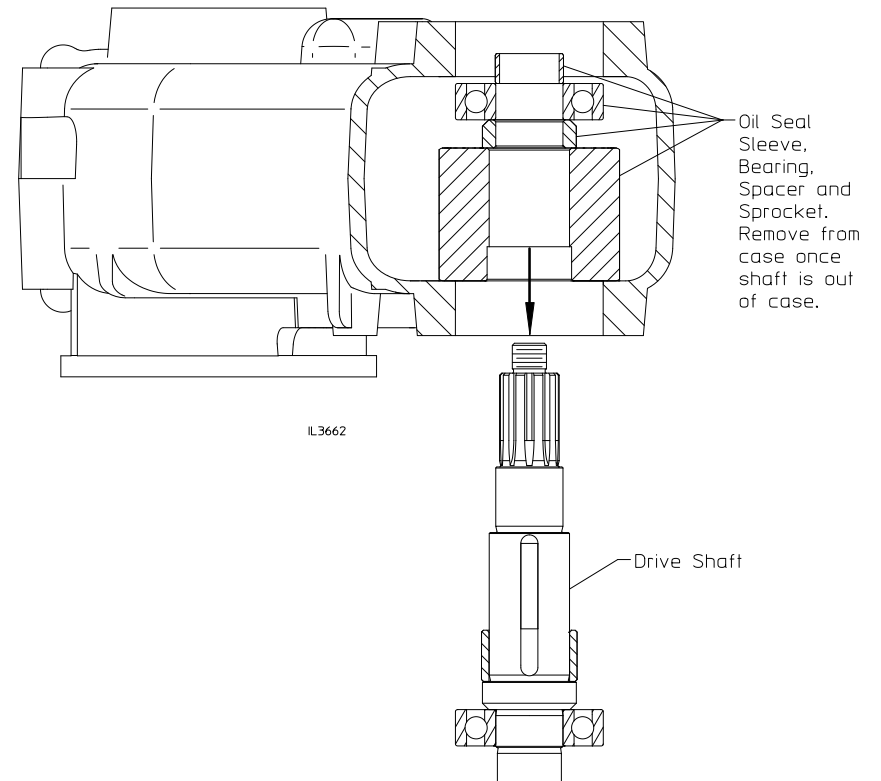
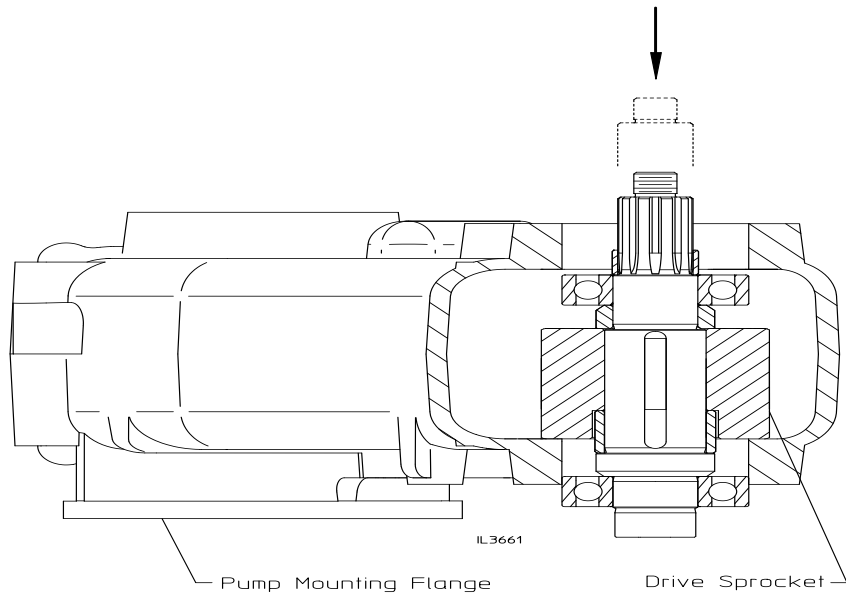

Disassemble Impeller Shaft

1. Remove the bearing locknut and washer.
2. Press the shaft out of the outboard bearing, spacer & sprocket while supporting the sprocket.
3. Remove the key.
4. Remove the spacers.
5. Press the shaft out of the inboard bearing.
6. The oil seal sleeve used prior to January 15, 2018 may be left on the shaft if undamaged. If damaged or upgrading to the latest shaft and oil seal design, remove.

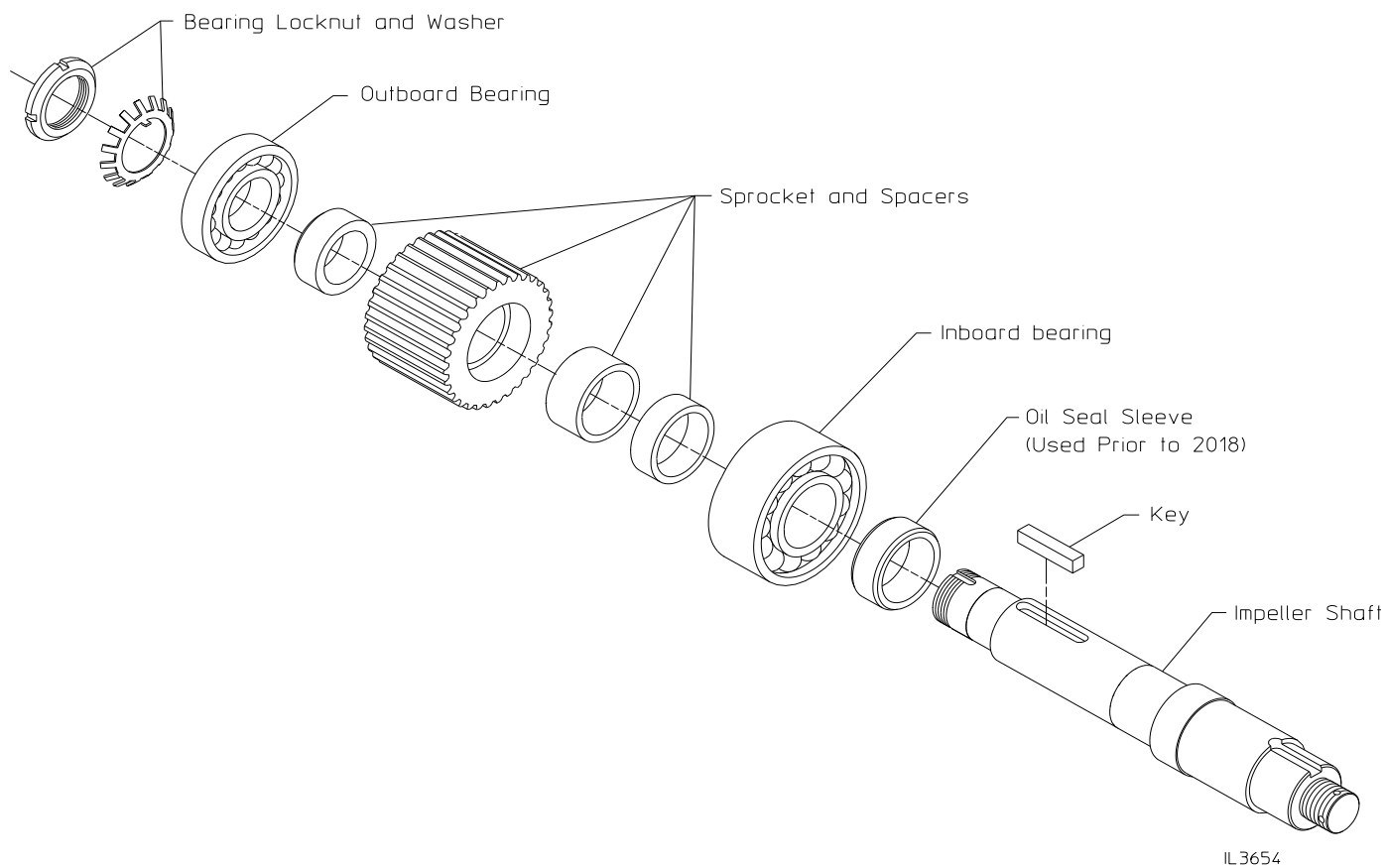

Disassemble Drive Shaft

1. Remove the sprocket key.
2. Remove the spacer.
3. Remove the outboard bearing.

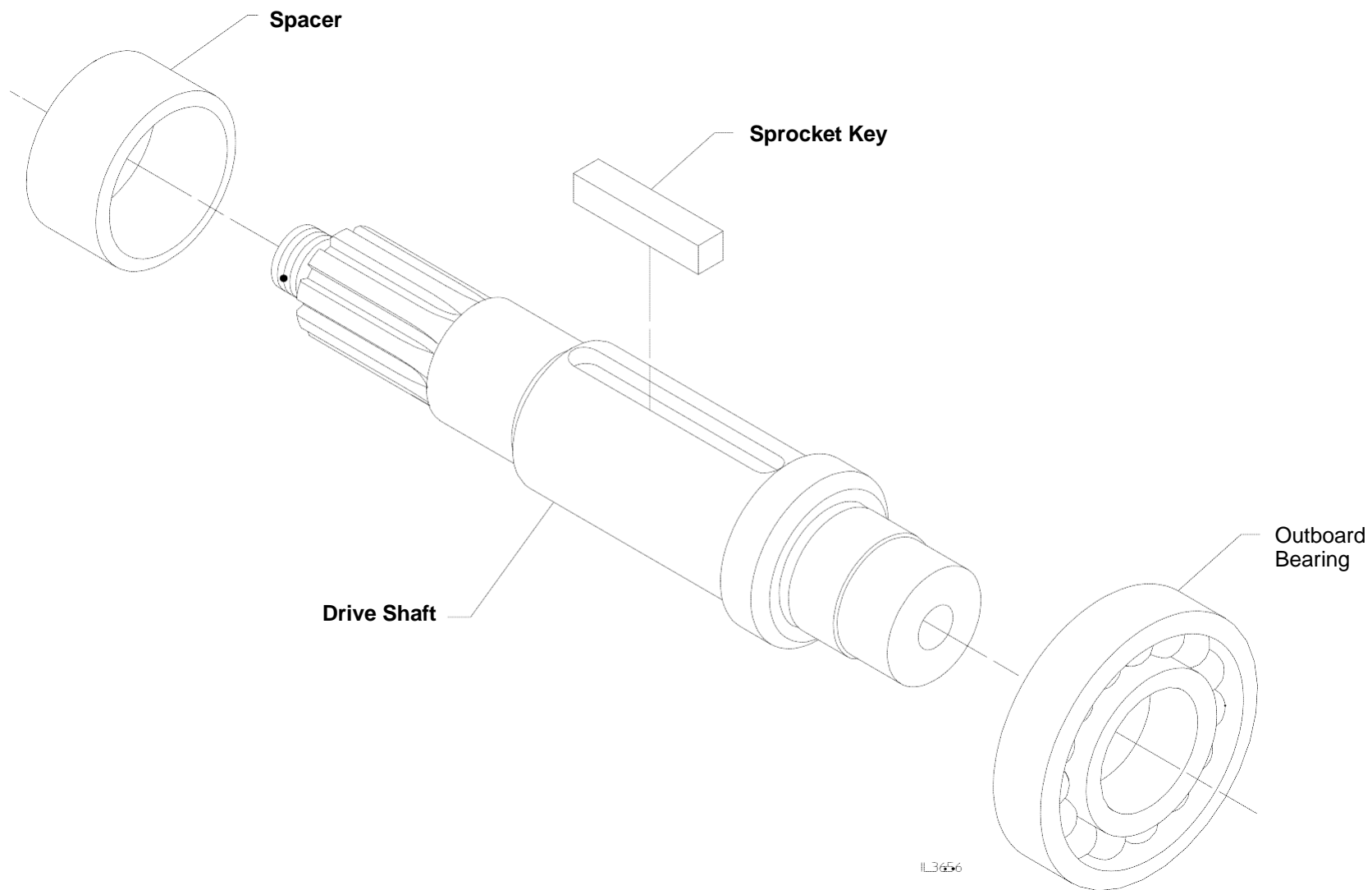

Inspection and Repair

Ball Bearings

When cleaning bearings, bearing manufacturers recommend placing them in a basket and suspending the basket in a container of solvent, preferably overnight. Avoid rotating the bearings before solid particles are removed, to prevent damaging races and balls.

After cleaning, spin them immediately in light oil and check each one as described below:

1. Examine bearing for rusted or pitted balls, races or cages.
2. Check cage and races for cracks or other damage. Examine balls and races for brinelling, abrasion and serious discoloration. If in doubt about condition of bearing, replace it.
3. Rotate bearing slowly, and check for roughness or excessive internal looseness. If a rough spot is found, it may be dirt caked on a race. Try cleaning it again. If endplay is doubtful, compare it with a new bearing. If the bearings are not to be installed right away, wrap them in clean, oil proof paper.

Inspection and Repair (Continued)

Impeller Shaft

Examine shaft for signs of severe scratches, grooves or corrosion, especially under the oil seal or mechanical seals. If scratches are not severe, and are not under seals, they can be ignored. Check for cracks, pitting or damaged keyway.

Oil Seal Sleeve

Check for wear and scratches where the seal contacts the sleeve. The journal may be polished with a fine emery cloth, however; any polishing that leaves a spiral pattern may lead to an oil leak. If a groove has been worn in the sleeve, it can be reused by turning it end for end.

Volute Body and Intake Adapter

Examine for cracks, severe corrosion or other damage. Almost all damage to these parts results from improper use or maintenance, or from freezing. Replace defective parts.

Throttle Bushing

Note: The bushing serves as a restriction to fluid leakage if the mechanical seal fails.

Scratches in the area of the bellows of the mechanical seal can possibly be removed by spinning the shaft in a lathe and polishing with a fine emery cloth. The journal for the oil seal may be similarly cleaned, however, spiral type polishing may lead to oil leaks.

If questionable, replace the sleeve or fit with a thin replacement sleeve. This replacement sleeve allows use of the same size oil seal. This type of repair sleeve is available through most sources of oil seals.

Clean out drainage holes in volute body located between the seat for the throttle bushing and oil seal.

Examine the bore in the bushing for wear due to contact with the shaft. The original size of the bore is 2.760/2.762 in. (70.10 / 70.15mm).

If bore is larger than original dimension, replace.

Assemble Drive Shaft

1. Press the single row outboard bearing on the shaft.
2. Slide the spacer on the shaft.

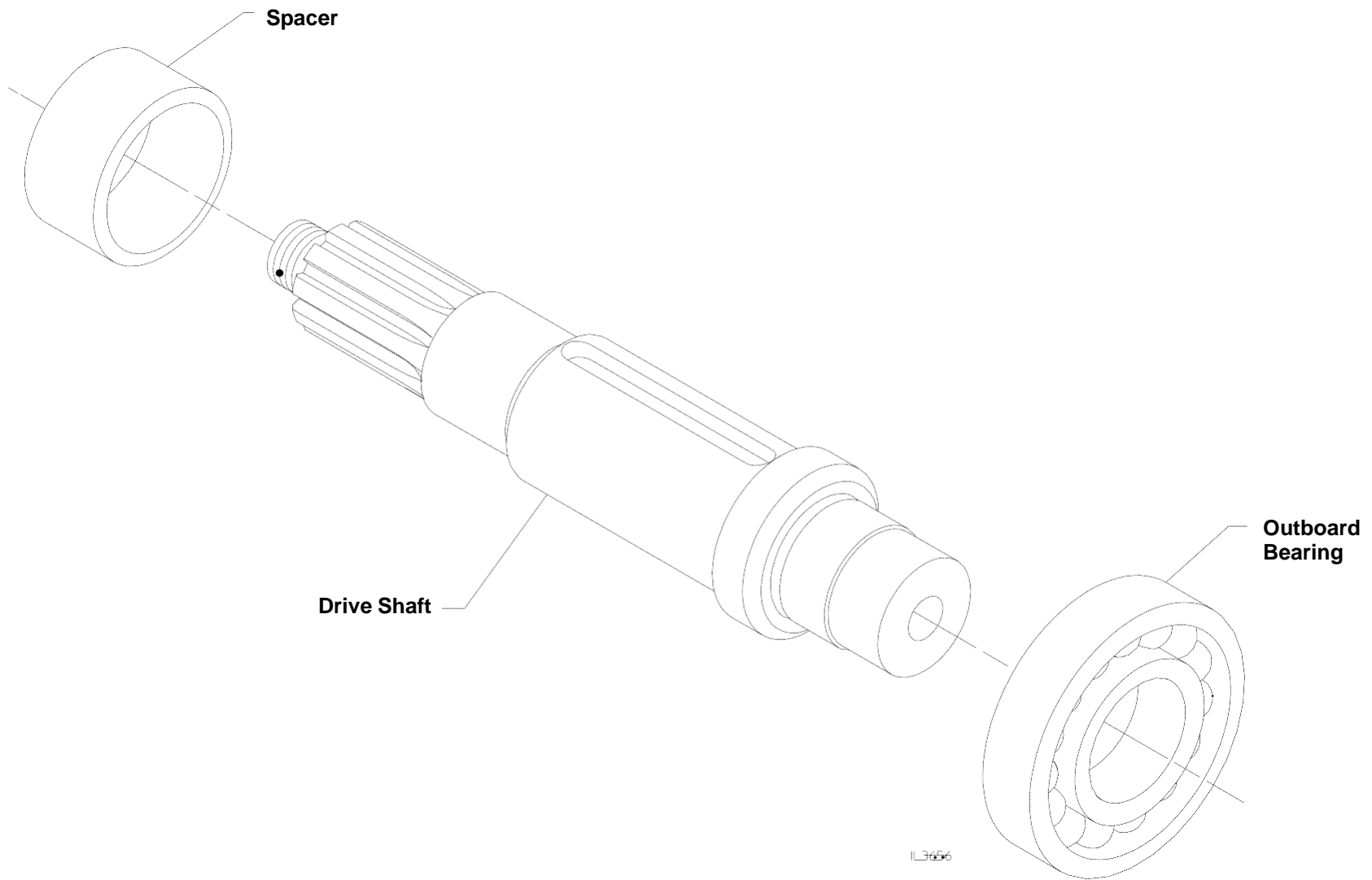

Assemble Impeller Shaft

1. Install the oil sleeve used on assemblies made prior to January 15, 2018 on shaft, if it was removed.
2. Press the double row bearing on shaft.
3. Install two spacers, key, driven sprocket and single spacer on shaft. Note that single spacer chamfer must face away from the drive sprocket.
4. Press the single row bearing on shaft.
5. Install the bearing washer and bearing locknut on the shaft. When retaining the shaft during locknut assembly, take care not to damage the mechanical seal journal on the shaft.
6. Tighten nut 1/4 turn from finger tight and engage a tab of bearing washer with slot of locknut.

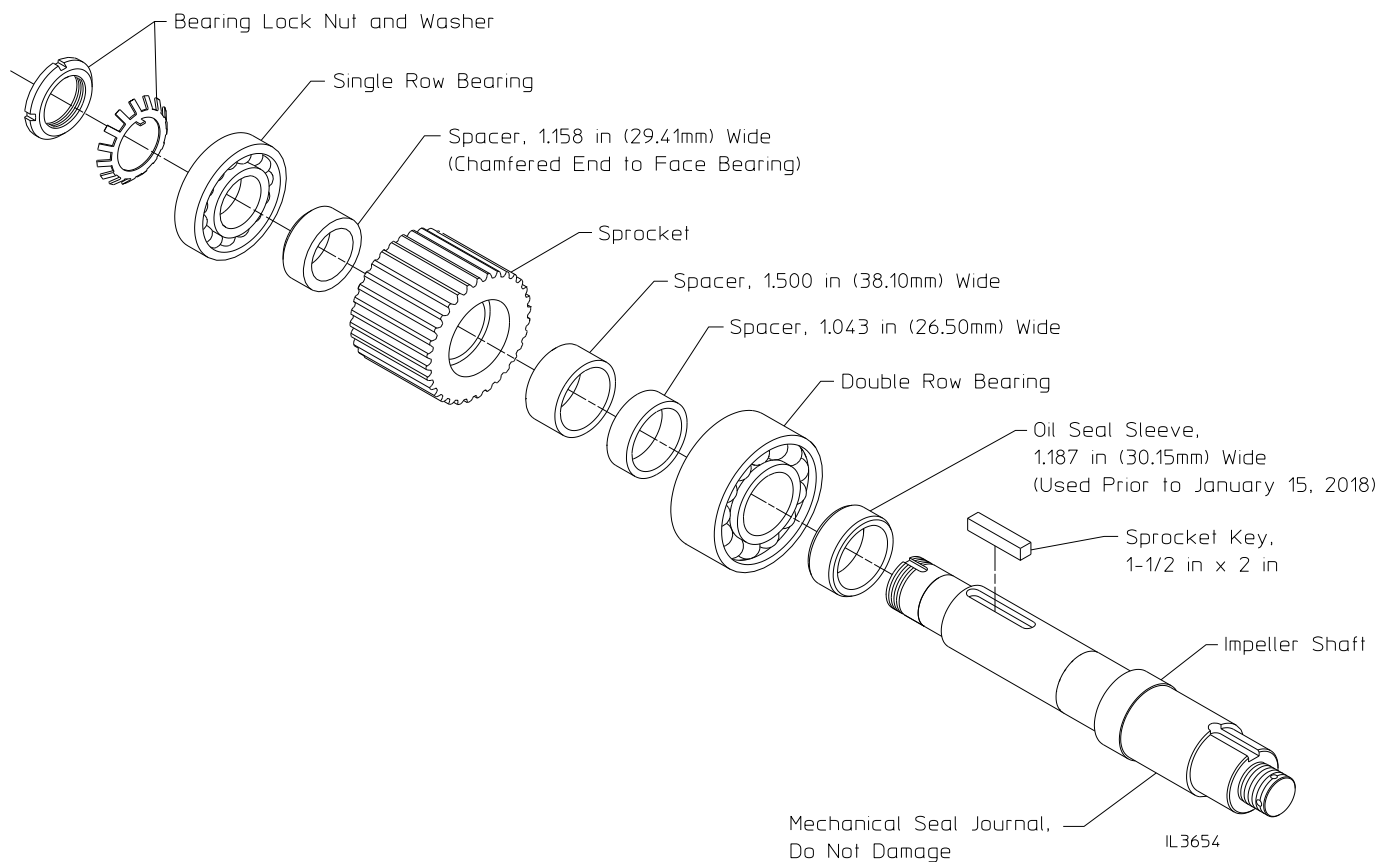

Reassembly - Install Drive Shaft

Installing Bearing in Case

1. Install bearing in case bore. Bearing is to be flush with face of case flange.
2. Lay the transmission case on its side with the pump flange facing up.
3. Reaching through the opening in the case, set the spacer and then the driven sprocket on the bearing installed in step one. Note that the chamfer on the spacer must face towards the bearing.

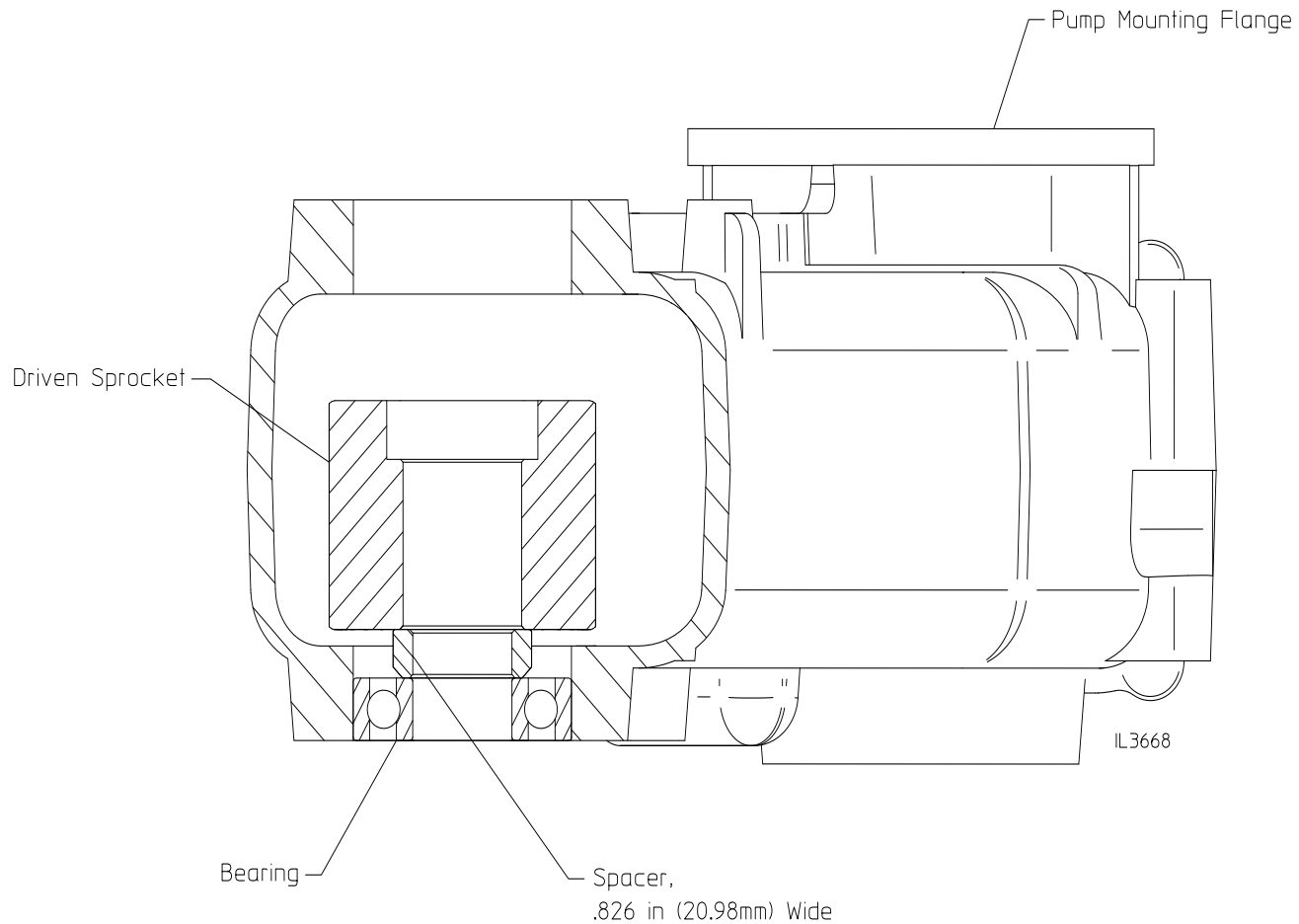

Install Drive Shaft in Case

4. Install the sprocket key in the drive shaft assembly.
5. Guide the drive shaft assembly into the sprocket bore.
6. Press the shaft assembly into the bore of the bearing previously installed in the case while guiding the bearing on the shaft assembly into the case bore.

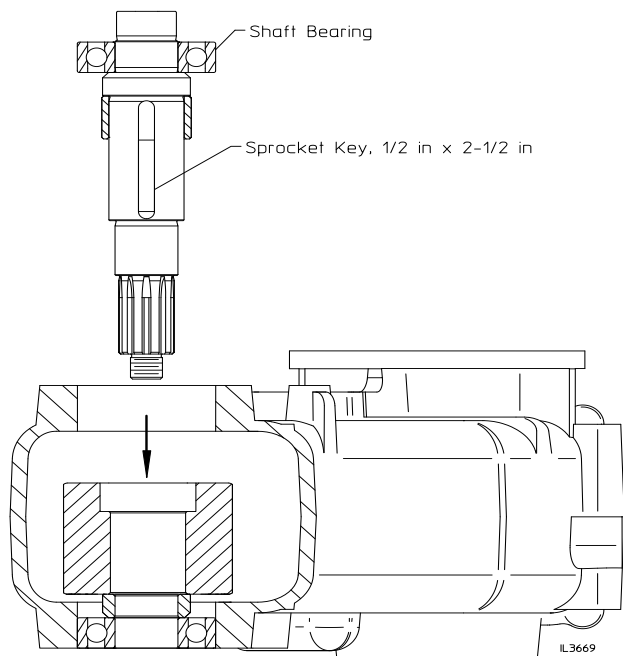

Adjust Position of Shaft

7. Tap the outer race of the bearing on the splined end of the shaft back until it is located .500 in. (12.70 mm) below the face of the case flange.

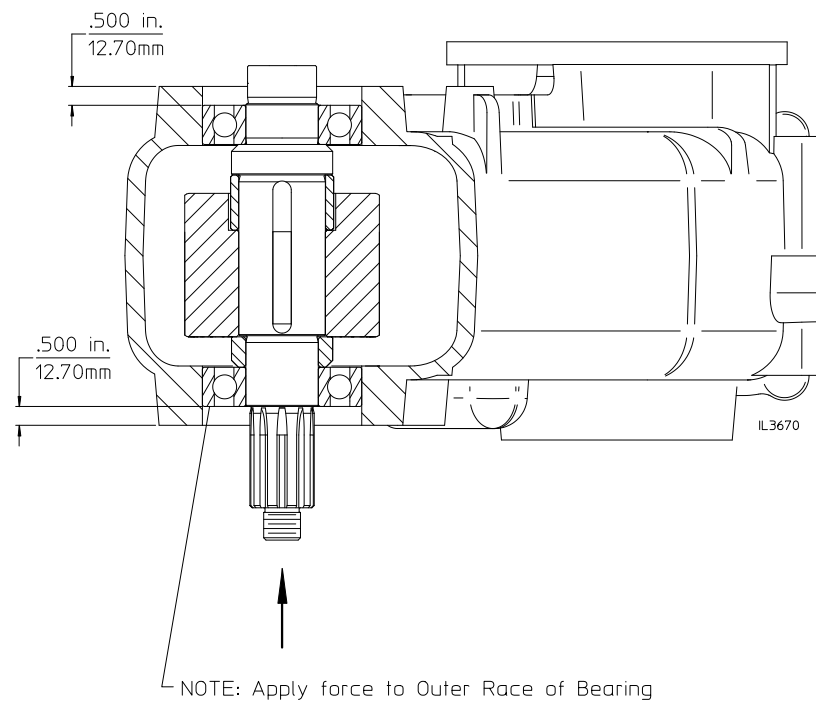

Install Oil Seal Housing Cover and End Yoke

8. Install the wave spring in the case bore.
9. Install the oil seal sleeve on the shaft.
10. Install the oil seal and O-ring in the oil seal housing.
11. Install the oil seal housing on the case, lightly tap into the case bore.
12. Install the four (4) screws and lockwashers. Torque to 31 lb-ft.
13. Install the end yoke on the shaft.
14. Install the washer and locknut. Torque to 400-450 lb-ft.

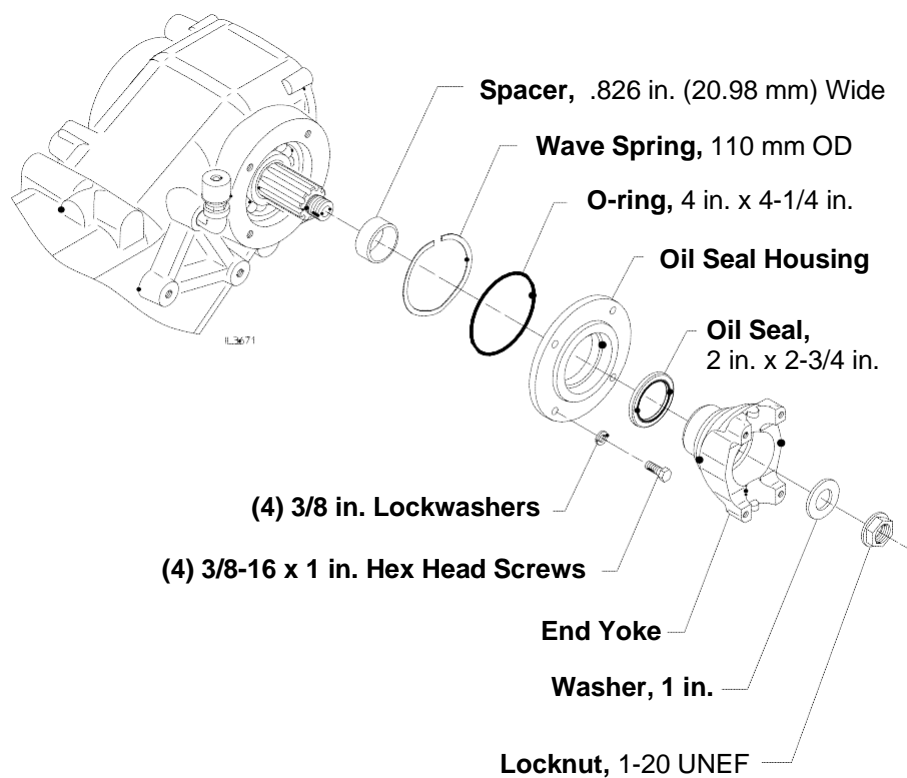

Install Hydraulic Adapter

15. Install the oil seal and O-ring in the hydraulic adapter.
16. Install the hydraulic adapter on the case. Lightly tap into the case bore.
17. Install the four (4) screws and lockwashers. Torque to 31 lb-ft.
18. Install the hydraulic pump/motor on the adapter.

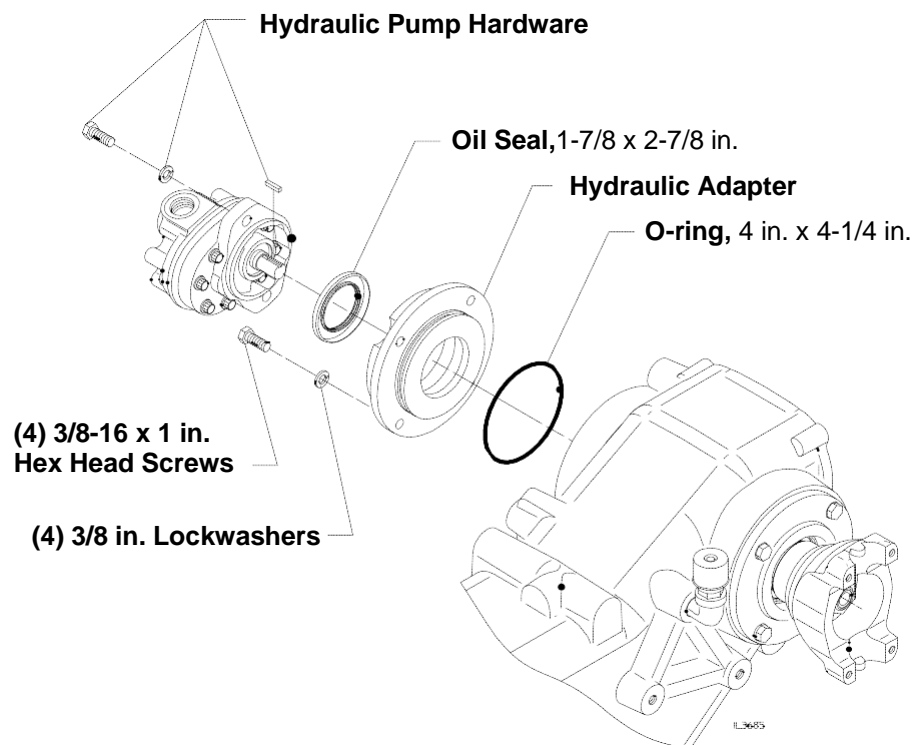

Reassembly - Install Impeller Shaft

Install Impeller Shaft in Case

1. Lay the transmission case on its side with the pump flange facing up.
2. Guide the impeller shaft assembly into the case bore.
3. Drive the shaft assembly into the case until the face of the double row bearing is located .437 in. (11.10 mm) below the face of pump mounting flange or the single row bearing is .562 in. (14.27 mm) inside the case face on the opposite side.

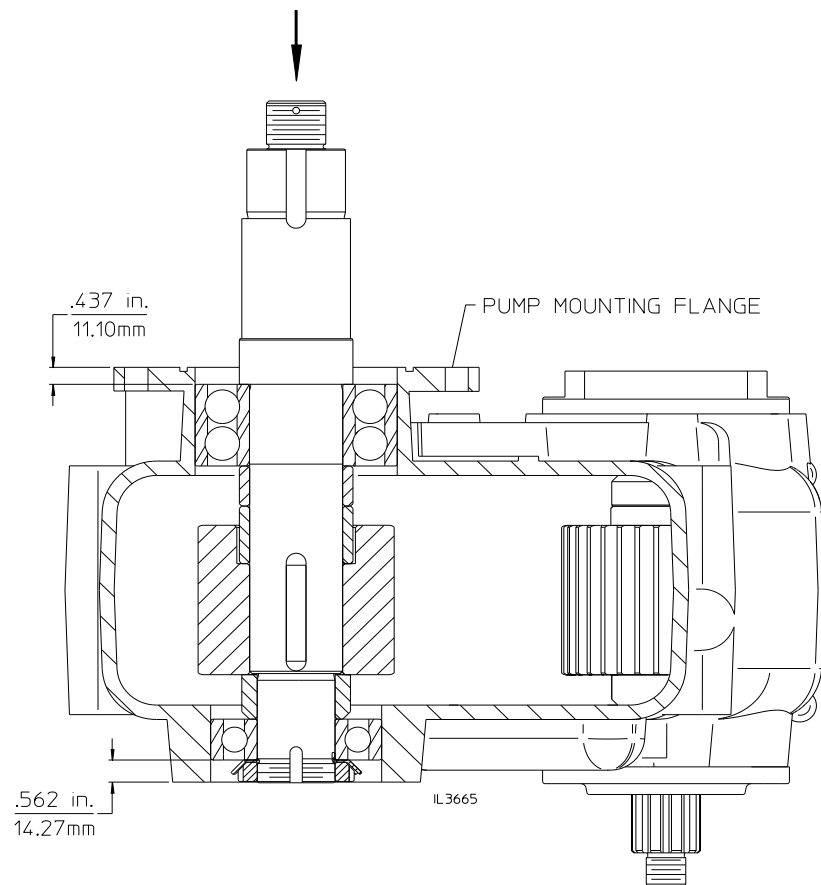

Install Bearing Cover

4. Install the wave spring in the case bore.
5. Install small O-ring in access hole groove.
6. Grease and install the large O-ring in groove of bearing cover.
7. Install the bearing cover on the case. Lightly tap into the case bore.
8. Install the four (4) screws and lockwashers. Torque to 31 lb-ft.

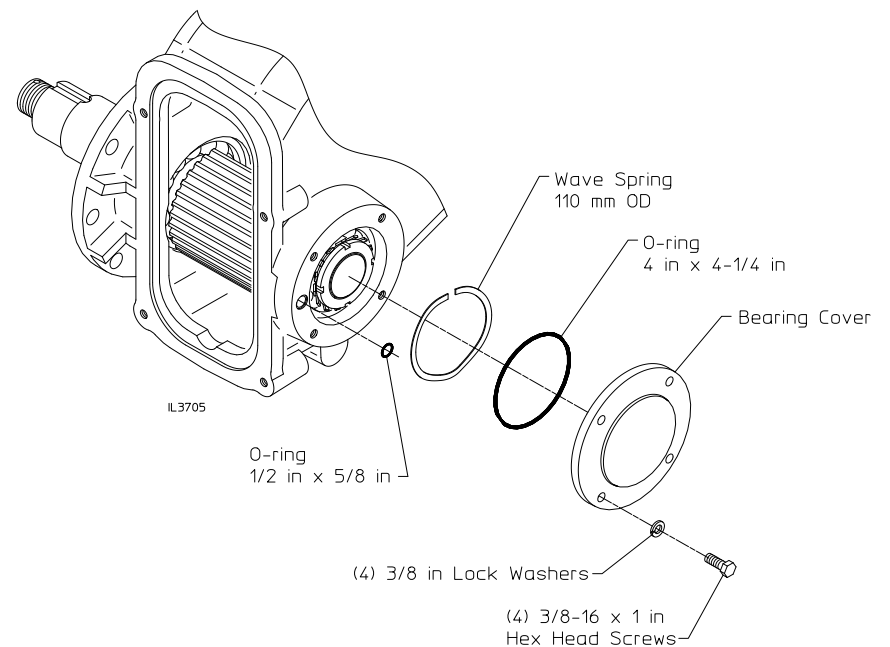

Reassembly - Install Pump Chain

Install Chain in Case

1. Clean the chain with a degreasing agent to remove any protective coating.
2. Drop the chain into the top end of the case while wrapping the chain around the drive sprocket. Ensure that the chain links are completely engaged by the sprocket teeth.
3. Wrap the ends of the chain around the driven (impeller shaft) sprocket and lace the ends together.

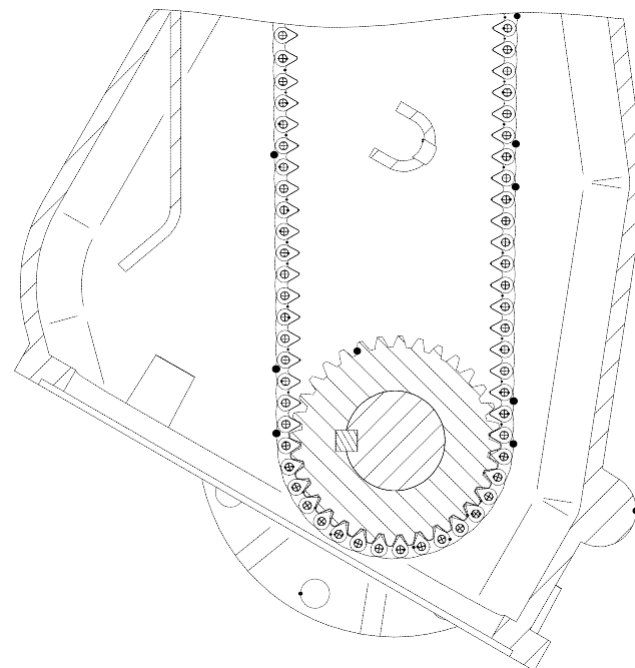
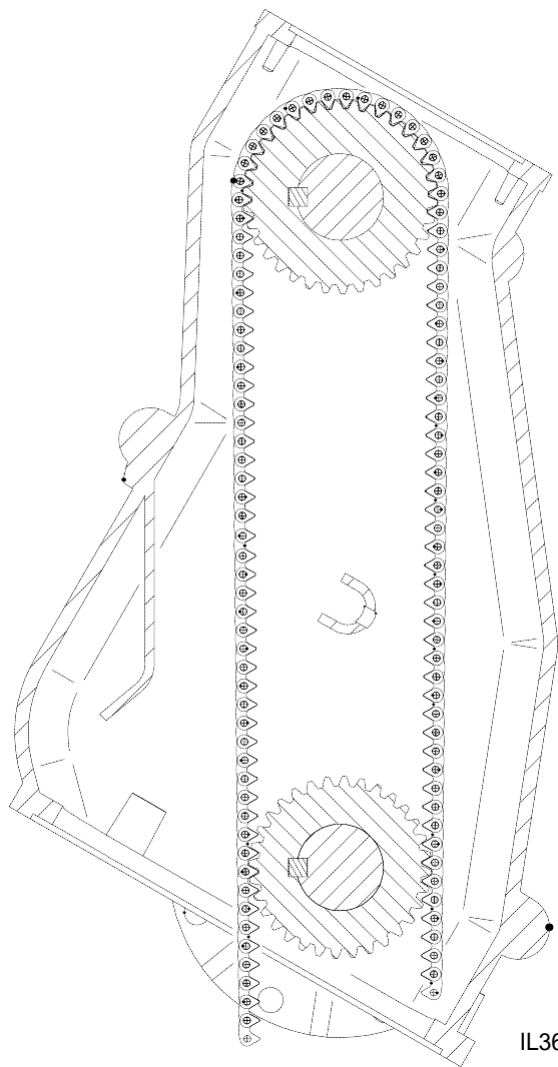

Connect Chain

4. Rotate the impeller shaft until the joined end joint is aligned with the access hole in the case.

5. Restrain the impeller shaft to prevent movement during the next steps.
6. Install the connecting pin rocker through the access hole and into the chain. Drive in until flush with the chain. Note that the curved side of the connecting pin rocker must be towards the center of the chain hole.

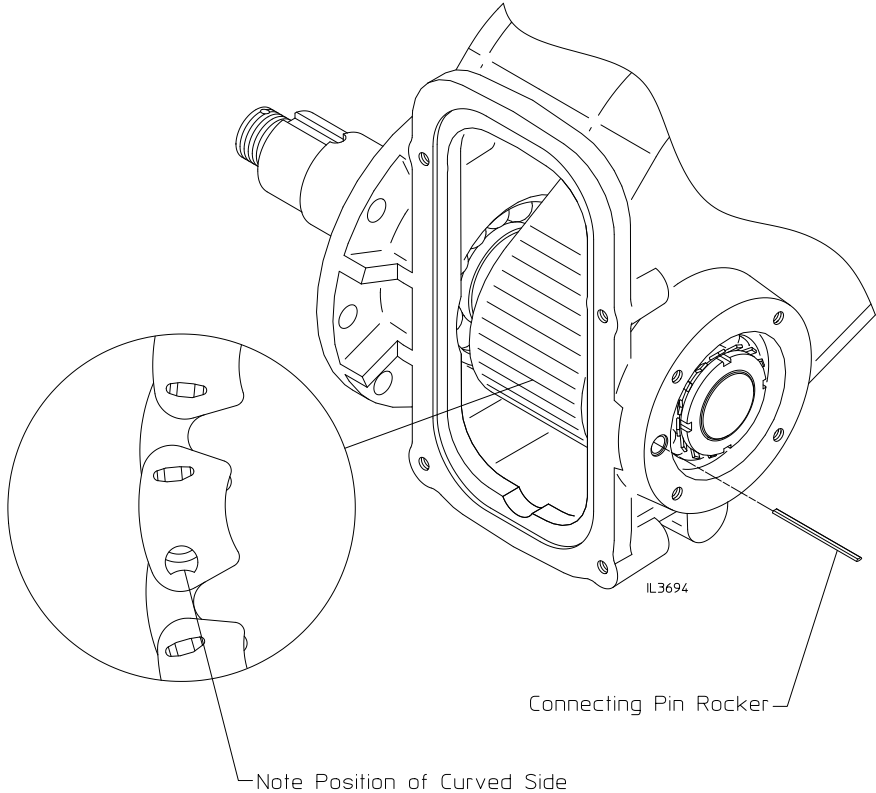
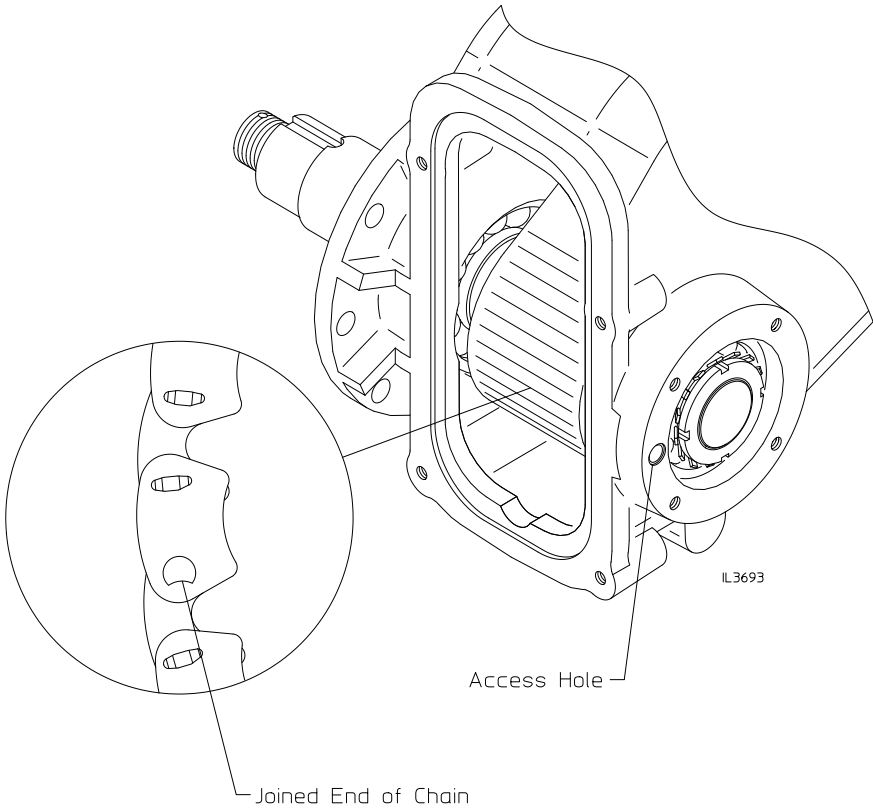

Connect Chain (Continued)

7. Install the connecting pin along side the connecting rocker in the chain hole. Drive in until the spiro pin is flush with the chain. Note that the curved side of the connecting pin must be towards the center of the hole.

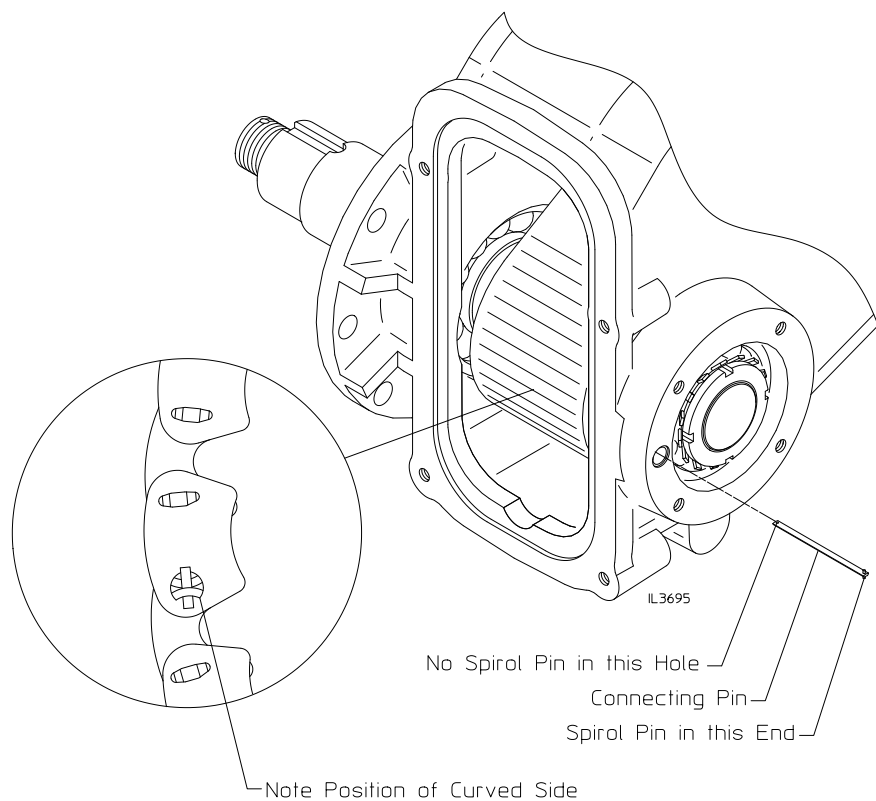

8. Install the spiro pin in the connecting pin hole on the opposite side of the driven sprocket. Ensure the spiro pin overlaps the connecting rocker.

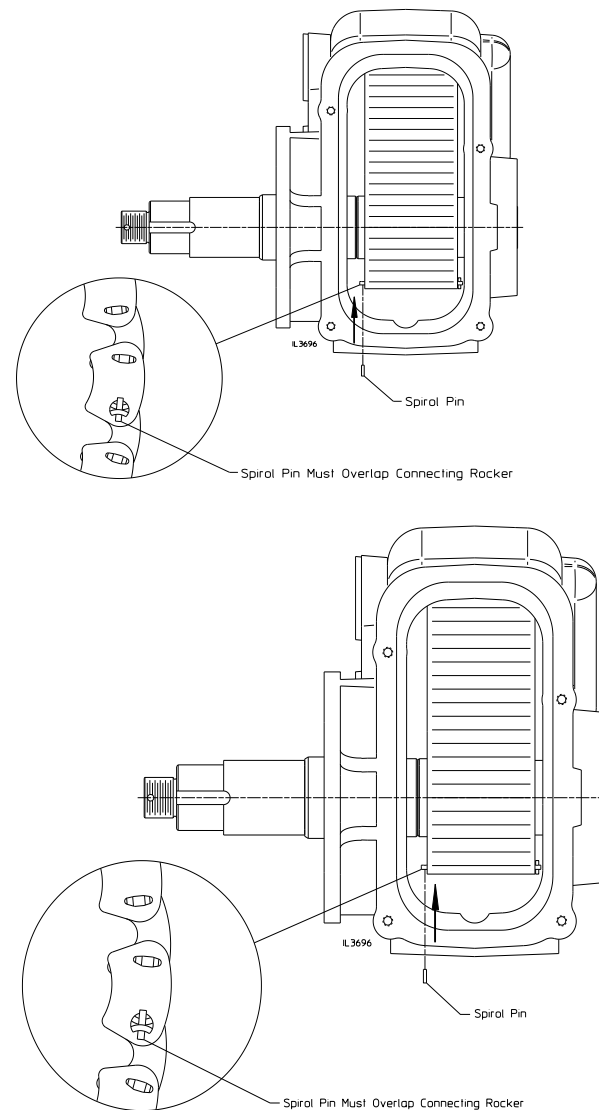

Install Case Covers

9. Install the oil pan and gasket. Install the four (4) screws and lockwashers. Torque screws to 31 lb-ft.
10. Install top cover and gasket. Install the four (4) screws and lockwashers. Torque to 31 lb-ft.

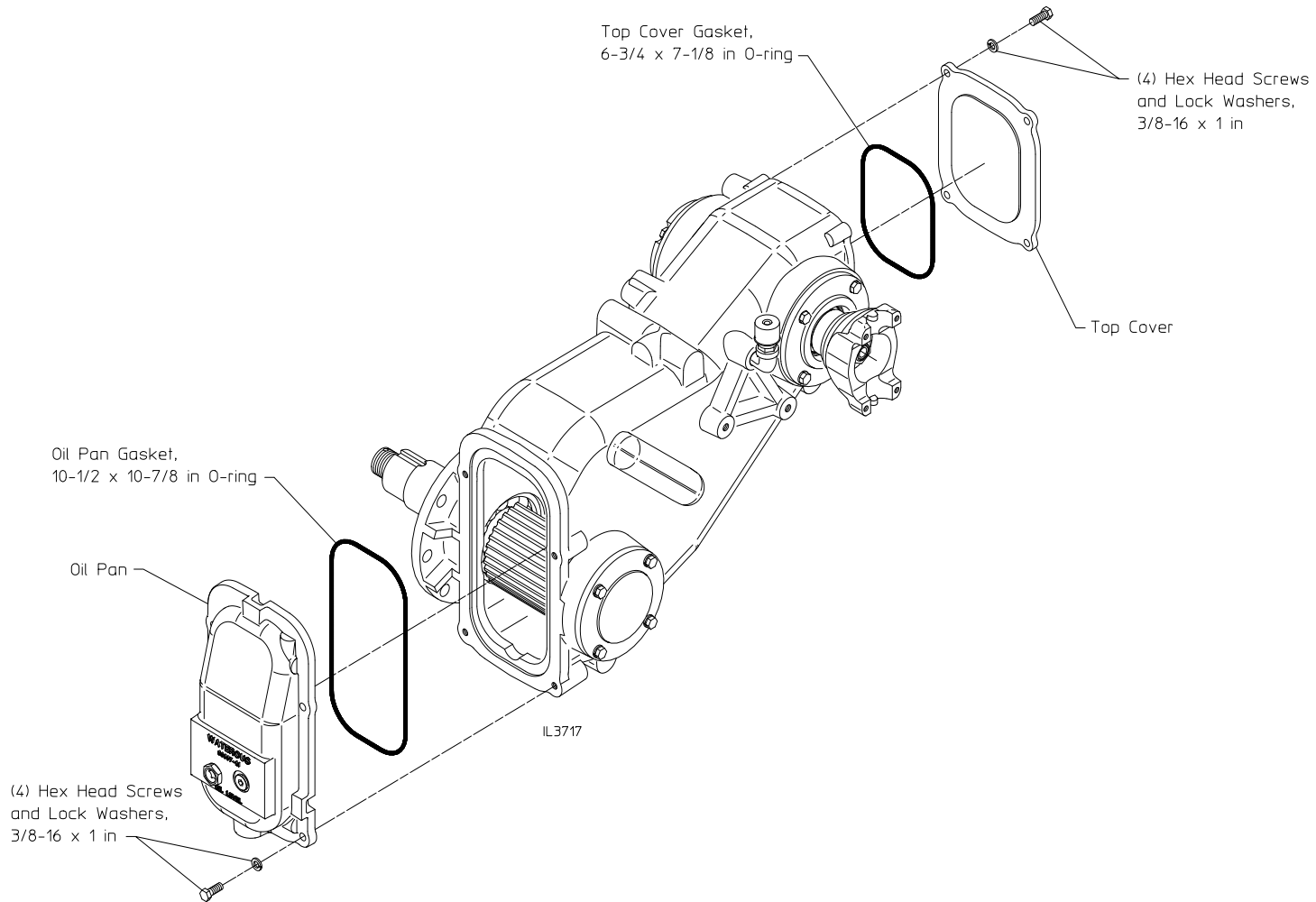

Reassembly - Install Pump on Transmission

Install Oil Seal in Pump Body

1. Install the oil seal in the bore of the pump body volute. Make sure the lip of the seal is facing toward the transmission.

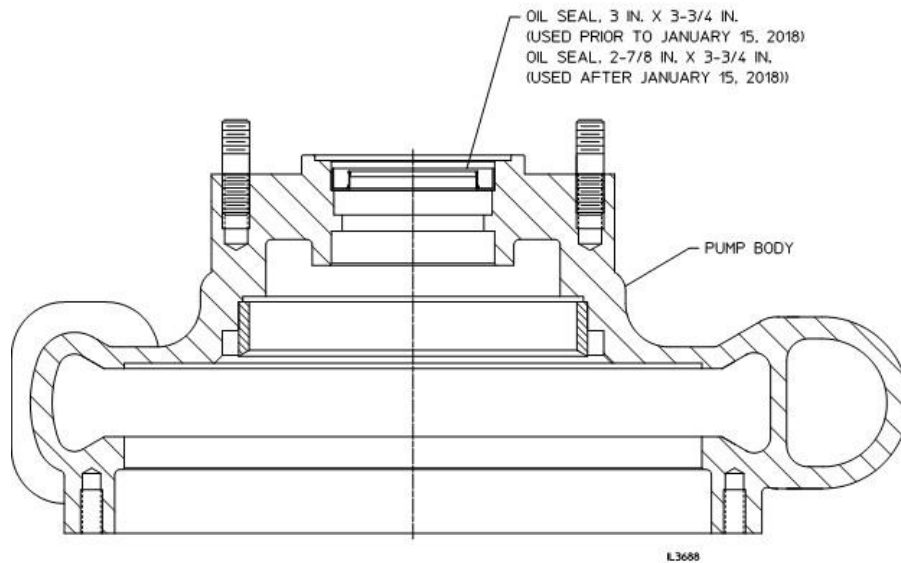

Install Pump Body on Transmission

2. Install the O-ring in transmission flange groove.
3. Install the pump body on the transmission taking care not to damage the oil seal. The shoulder on the shaft can be wrapped with tape to provide a ramp for the oil seal. Remove tape afterwards.
4. Ensure that the pump body discharge flange is orientated relative to the pump transmission the same as when disassembled.
5. Install the eight (8) nuts and lockwashers attaching the pump volute body to the transmission.

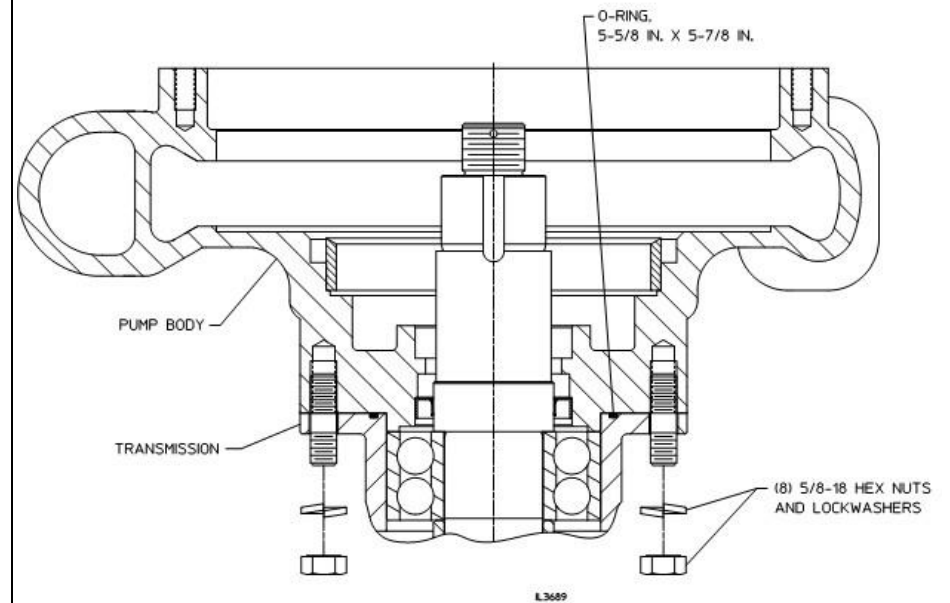

Final Assembly and Lubrication

Final Assembly Steps

1. Check all fasteners for tightness.
2. Install pump in vehicle.
3. Connect propeller or drive shaft to pump transmission.
4. Connect pump intake and discharge piping.
5. Connect cooling and drain lines, electrical wiring and similar equipment from pump and accessories.
6. Fill transmission with lubricant. See Lubrication Instructions.

Lubrication

Fill transmission with lubricant specified on Q series transmission operation and maintenance instructions.

Testing

Before a pump is returned to service, it is advisable to give it both hydrostatic and operational tests to check it for leaks and to make sure the pump operates properly.

Hydrostatic Testing

1. Connect pump to a hydrant or other pressurized water supply.
2. Close all drain lines and open discharge and priming valves.
3. Open hydrant until water runs out through discharge valves and discharge pipe in priming pump. Close all valves. Be sure to evacuate all air from pump.
4. Apply water pressure to pump for 15 minutes. Do not exceed 350 psi (24.2). With a portable light, check pump for leaks. If leaks are discovered, tighten connections or attaching parts as necessary.

Note: If a mechanical seal is used, it may leak under hydrostatic pressure. However, it should stop leaking after the seal faces are run-in during operation testing.

5. After all leaks are eliminated, shut hydrant valve, drain pump completely and disconnect intake hose.

Operational Testing

1. Operate pump at its maximum intended service pressure. Do not exceed 350 psi (24.2 bar) (450 psi, 31 bar with positive intake).
2. With a portable light, check pump for leaks. If leaks are discovered, stop pump and tighten connections or attaching parts as necessary. Repeat until all leaks are eliminated.
3. While pump is running, check for unusual noises, oil leaks, overheated bearings, etc. If anything unusual is discovered, stop pump immediately and determine the cause.