

WATEROUS

Form Number F-2902

Issue Date Aug 26, 2020

Overhaul Instructions Heavy-Duty Model TK Power Take-Off

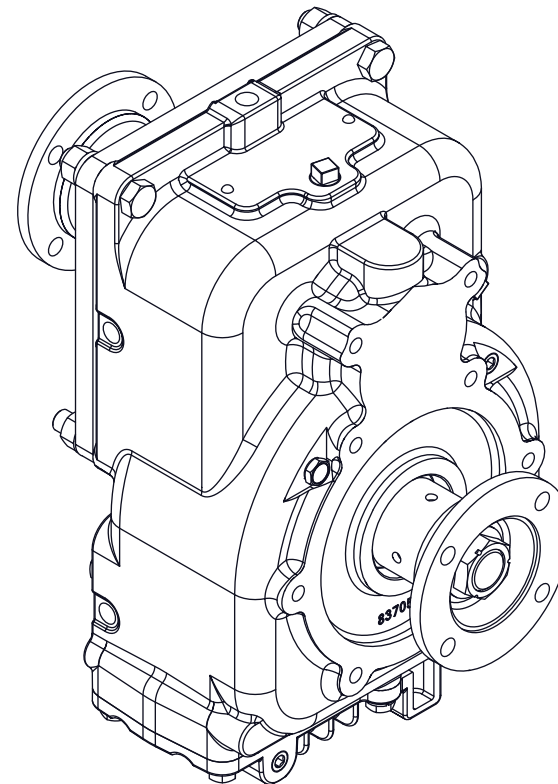
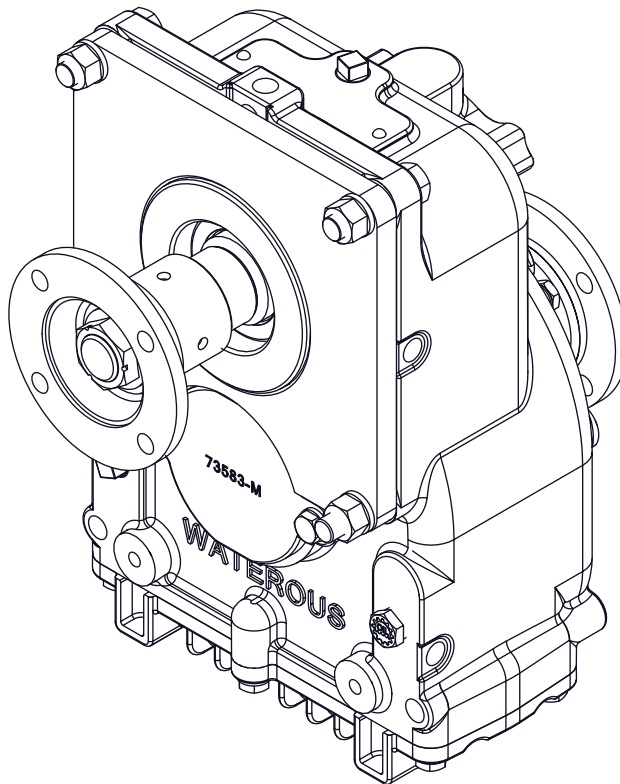

Table of Contents

Safety	5	Removing the Drive Components	15
Safety Precautions	5	Removing the Bearing Housing	16
Introduction	6	Assembly	17
Using this Document	6	Preparing to Assemble the Power Take-Off	17
Viewing the Document Electronically	6	Tools Required	17
Printing the Document	6	Best Practices	17
Symbols	6	Assembling the Power Take-Off Components	17
Identifying Exterior Components—Output Side	7	Installing the Power Take-Off	17
Identifying Exterior Components—Input Side	9	Understanding the Illustrations	17
Identifying Exterior Components—Bottom	10	Heavy-Duty TK Power Take-Off	18
Disassembly	11	Assembling the Bearing Housing	19
Preparing to Disassemble the Power Take-Off	11	Assembling the Impeller Shaft	20
Tools Required	11	Installing the Impeller-Shaft	22
Preparing the Apparatus	11	Assembling the Drive Shaft	23
Best Practices	11	Installing the Drive-Gear Components	24
Removing the Power Take-Off	11	Installing the Bearing Cover	25
Disassembling the Power Take-Off Components	11	Installing the Bottom Cover	26
Draining the Gear Oil	12	Installing the Drive-Shaft Components and Rear Adapter	27
Removing the PTO Adapter and Plate	13	Installing the Impeller Shaft Components and Front Adapter	28
Removing the Bottom Cover	14	Adding Oil to the Power Take-Off	29

Safety Precautions

- Read and understand this document before you begin the overhaul.
- Read and understand all the notices and safety precautions.
- Be aware that these instructions are only guidelines and are not meant to be definitive. Contact Waterous when you have questions.
- Do not overhaul this equipment if you are not familiar with the tools and skills needed to safely perform required procedures.
- Do not modify the equipment.
- Waterous reserves the right to make modifications to the instructions without notice.

 WARNING	
Hot Surface <ul style="list-style-type: none">• Hot surface can burn you.• Do not touch the surface during operation—allow it to cool after operating.	

Use this document to overhaul your Waterous equipment. Please understand the following conditions:

- Be aware that these instructions are only guidelines and are not meant to be definitive. Contact Waterous when you have questions.
- Understand that your configuration may require additional steps, that are not described in the illustrations or instruction, to perform the overhaul.
- The equipment described in this document is intended to be overhauled by a person or persons with the necessary skills and knowledge to perform the overhaul.

This document is divided into the following sections:

SAFETY

This section describes general precautions and alert symbols that are in this document.

INTRODUCTION

This section is an overview of the document.

DISASSEMBLY

This section describes disassembly procedures.

ASSEMBLY

This section describes assembly procedures.

Using this Document

Use the guidelines below when viewing this document.

Viewing the Document Electronically

- View this document in landscape orientation.
- Use the table of contents to navigate directly to that section.

Printing the Document

- The document is viewed the best when printed in color.
- The *print on both sides* and *flip on long edge* features can provide the best results.
- Use a 3-ring binder to store the document.

Symbols

Symbols are use to illustrate additional tools or operations that are required to complete the instruction.



Arbor press—This symbol tells you to use an arbor press to complete this step.



Sealant—This symbol tells you to apply a appropriate sealant to the part.



Section reference—This symbol tells you to refer to the section reference for additional information.



Torque to specification—This symbol tells you to torque the hardware to the specified value.



Discard—This symbol tells you to discard or recycle the part in accordance with local regulations.



Finger tight, then quarter turn—This symbol tells you to secure the hardware to finger tight and then use a wrench to turn the hardware an additional quarter turn.



High-pressure grease—This symbol tells you to apply high-pressure grease to the surfaces that you are pressing together.

Identifying Exterior Components—Output Side

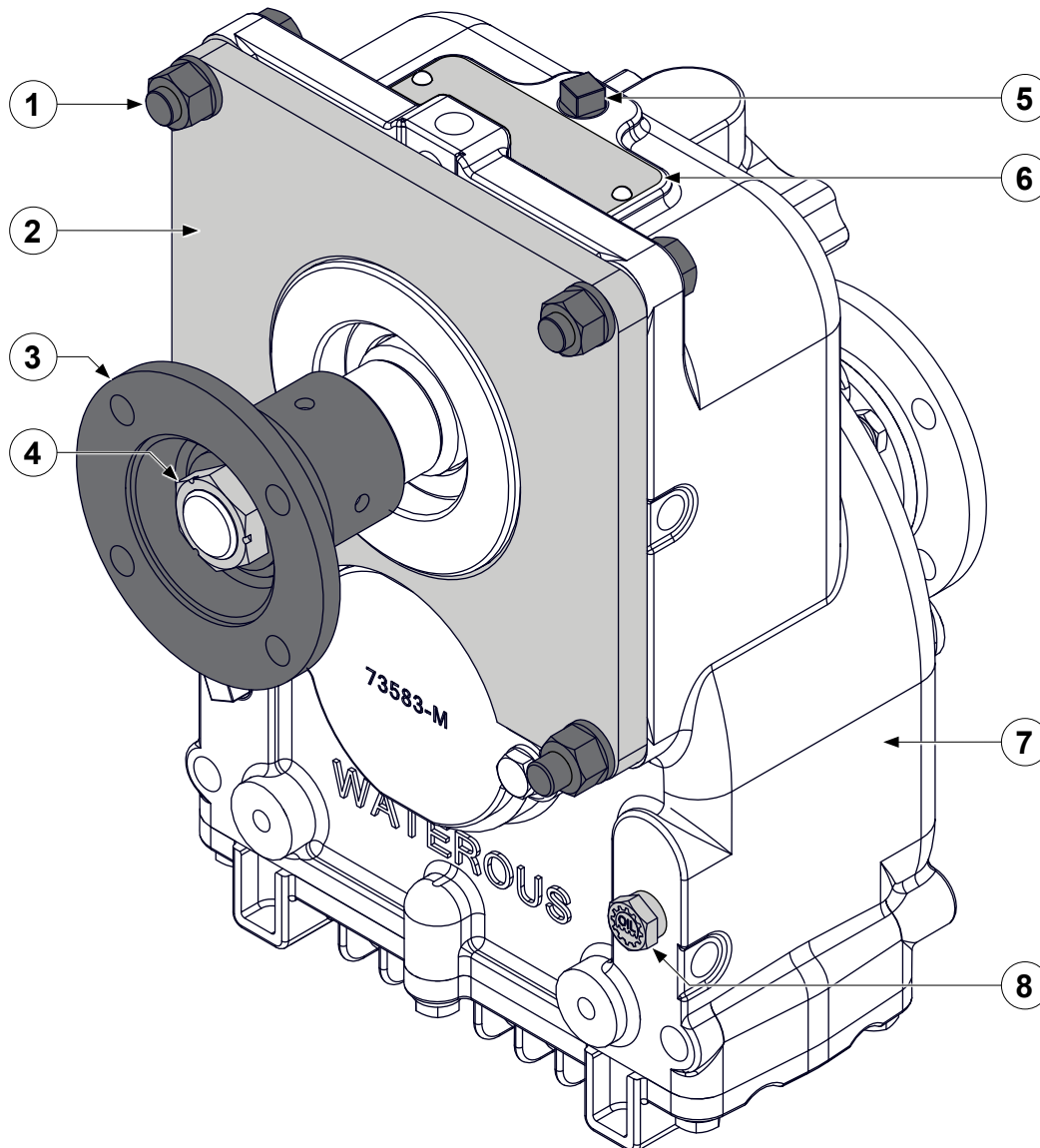

Use the illustration to identify various components on the power take-off (PTO).

- | | |
|---|---|
| 1 | Mounting hardware |
| 2 | Adapter plate |
| 3 | PTO adapter |
| 4 | PTO-adaptor nut |
| 5 | Oil-fill plug—location varies by application |
| 6 | Serial-number plate |
| 7 | Case |
| 8 | Oil-level plug—location varies by application |

Identifying Exterior Components—Output Side

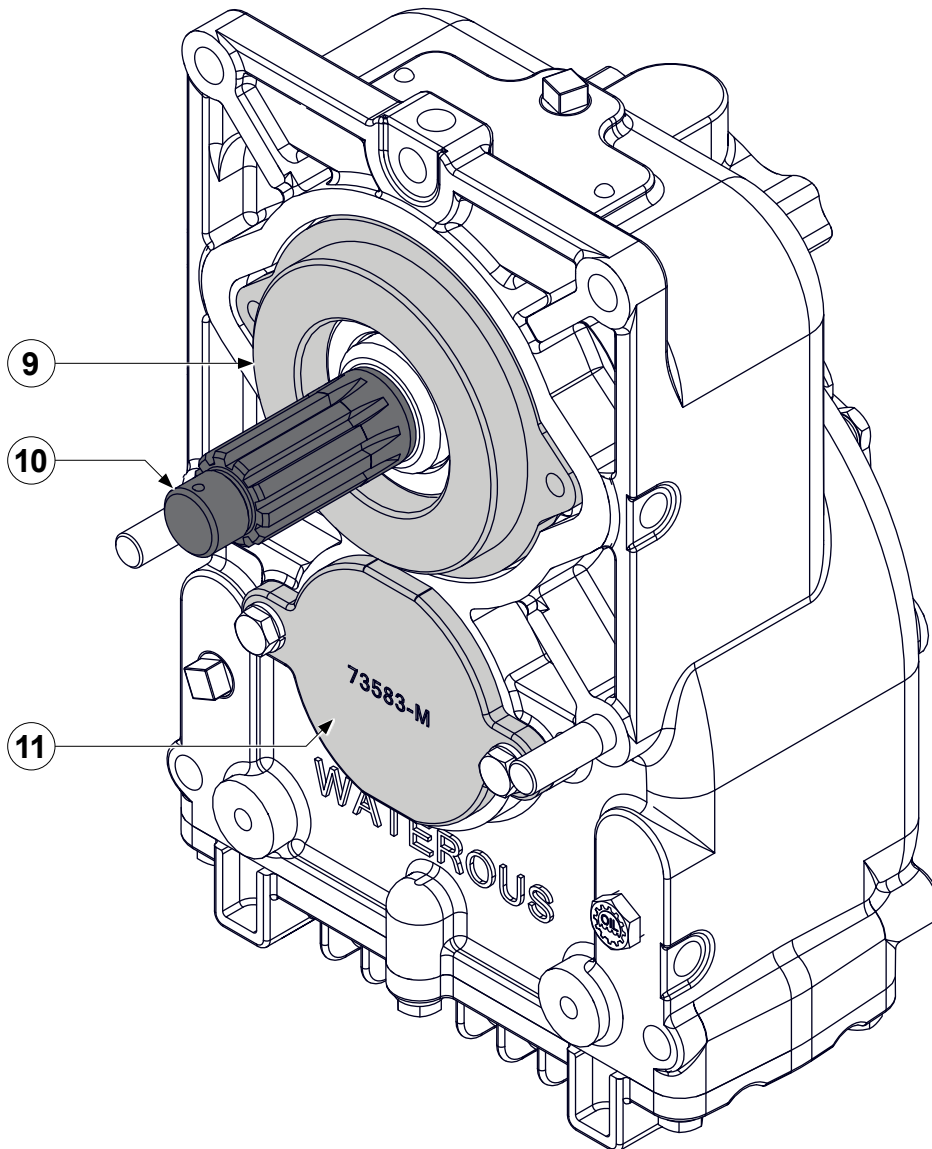

Use the illustration to identify various components on the power take-off.

- | | |
|----|---------------------------|
| 9 | Bearing housing |
| 10 | Output shaft |
| 11 | Drive shaft bearing cover |

Identifying Exterior Components—Input Side

Use the illustration to identify various components on the power take-off.

- 1 Breather—location varies by application
- 2 PTO adapter
- 3 PTO-adapter nut

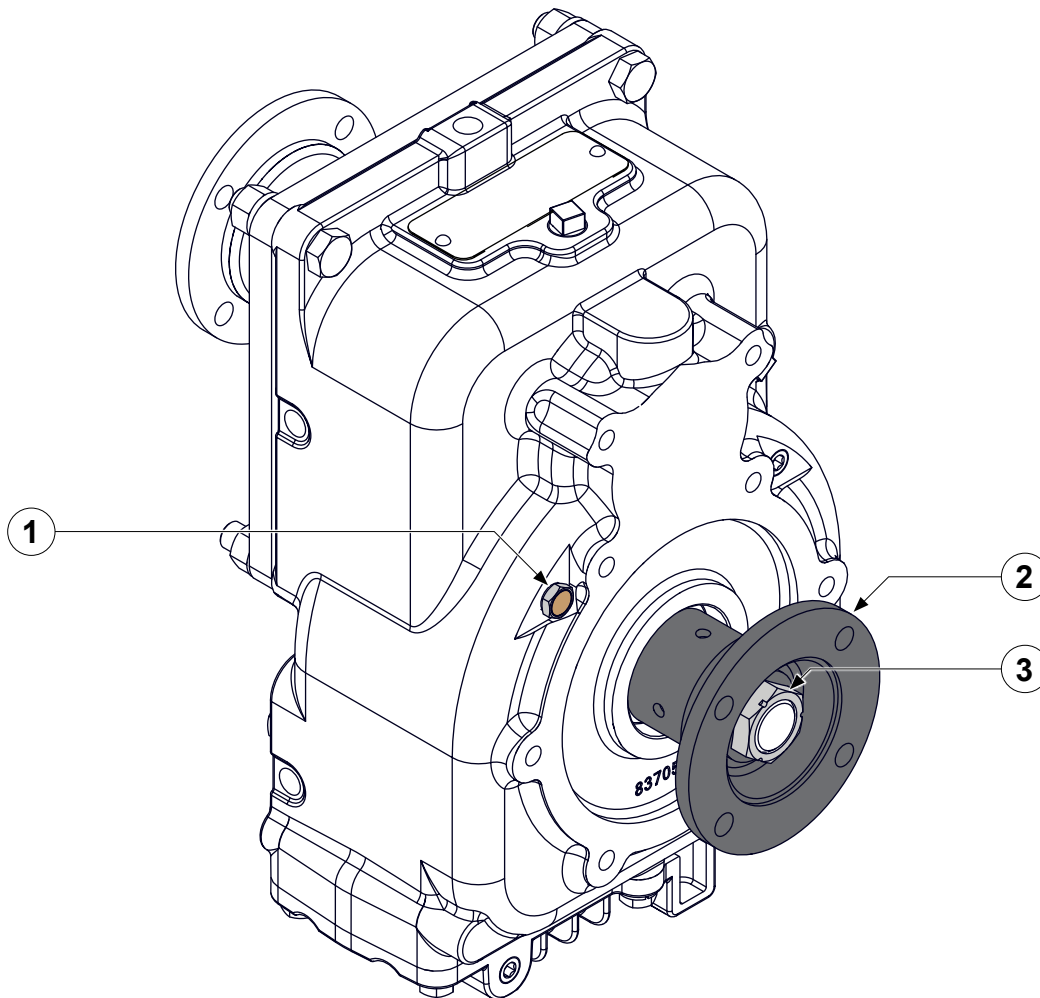

Identifying Exterior Components—Bottom

Use the illustration to identify various components on the power take-off.

- | | |
|---|---|
| 1 | Oil cooler-mounting hardware |
| 2 | Oil-cooler pan |
| 3 | Drive shaft |
| 4 | Oil-cooler drain |
| 5 | Gear-oil drain—location varies by application |

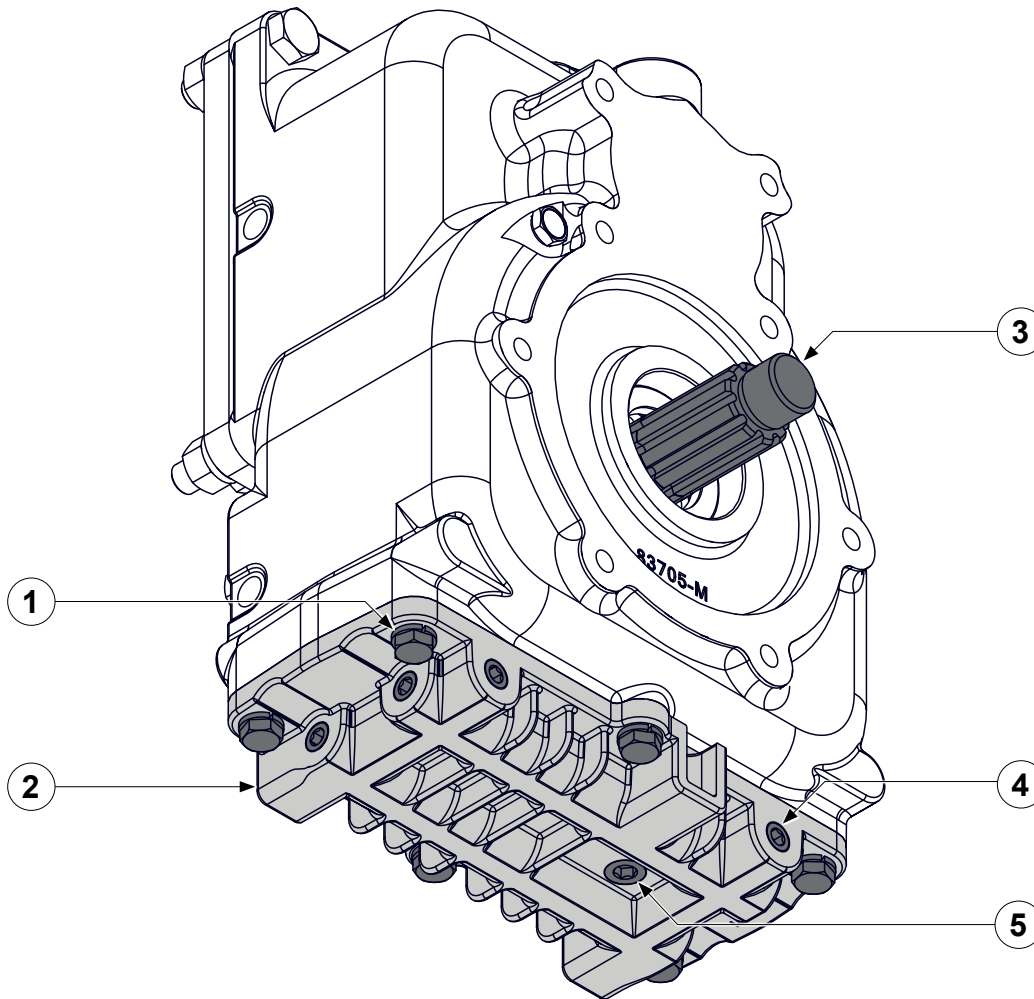

Preparing to Disassemble the Power Take-Off

- Read and understand the instructions before disassembling the equipment.
- Prepare a workspace suitable to accommodate and support the power take-off.
- Gather the necessary tools, cleaning cloths, brushes, and penetrating fluids.
- Understand that your configuration may require additional steps that are not described in the illustrations or instruction to perform the disassembly.
- This equipment is intended to be disassembled by a person or persons with the basic knowledge of servicing similar equipment. Contact Waterous with questions.

Tools Required

- Typical automotive mechanics hand tools.
- Suitable arbor press.
- Suitable support and lifting equipment.

Preparing the Apparatus

- Park the apparatus on a level surface, in a well-lit area.
- Engage the parking brake.
- Shut off the engine and remove the key from the ignition switch.
- Allow the apparatus to cool before servicing.

Best Practices

- Remove any dirt, sand, grease, or oil from the enclosure before you disassemble the power take-off. Surface debris can transfer into the pump interior and prematurely wear internal parts.
- Only use a clean lint-free cloth, a debris free work surface, and properly maintained tools to perform the disassembly.
- Replace any gaskets and o-ring seals during the overhaul.
- Do not reuse the self-locking nuts.
- Apply penetrating oil to screws and nuts before disassembly.

Removing the Power Take-Off

Removing the power take-off for overhaul varies by application. Your application may require components such as cooling lines, support brackets, plumbing connections, and other accessories be removed or disconnected before removing the power take-off.

Record the process used to remove the equipment from the apparatus. Use this information to install the equipment into the apparatus after the overhaul.

Disassembling the Power Take-Off Components

- Refer to the service parts list (SPL) for part identification and disassemble order.

Note: Documents specific to your application are available through the MyWaterous login at Waterousco.com by entering the serial number for your system. Depending on the application, the serial number for your equipment is located on the operator panel, or the pump, or the power take-off, or some combination of the three.

- Use established industry practices to disassemble the power take-off.
- Record or mark components as you remove them to make sure that you install them in the same orientation.
- Discard or recycle drained fluids collected during the overhaul in accordance with your local regulations.

Draining the Gear Oil

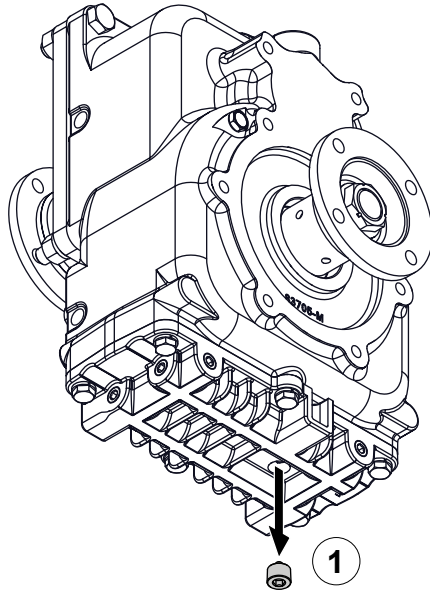

Use the illustrations and instructions to drain the oil from the power take-off. The illustrations may not represent your specific power take-off orientation. Refer to the SPL for your application to locate the oil-drain plug for your orientation.

Note: *Locate the oil-fill plug to approximate the amount of oil in the power take-off. Use this information to determine a suitable container to collect the drained oil.*

- 1 Perform the following to drain the oil:
 - Place a suitable container under the power take-off to collect the drained oil.
 - Locate, remove, and set aside the drain plug.
 - Allow the oil to drain.
- 2 Install the drain plug.

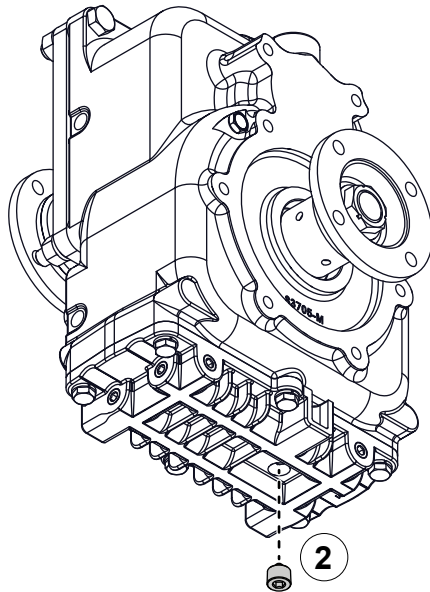

Removing the PTO Adapter and Plate

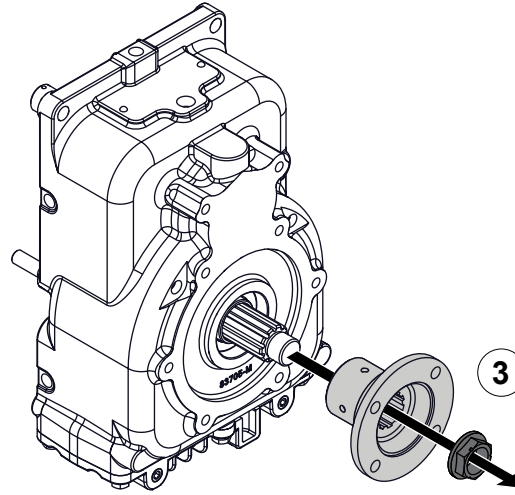
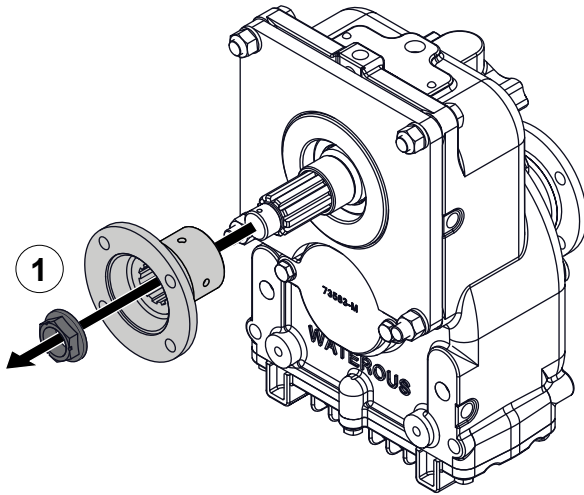

Use the illustrations and instructions to remove the PTO adapters and plate.

- 1 Remove the adapter nut and adapter, and set them aside.
- 2 Remove hardware securing the adapter plate to the power take-off. Remove the adapter plate and spacer, and set them all aside. Remove and discard the seal.
- 3 Remove the adapter nut and adapter, and set them aside.
- 4 Remove the spacer and set it aside. Remove and discard the seal.

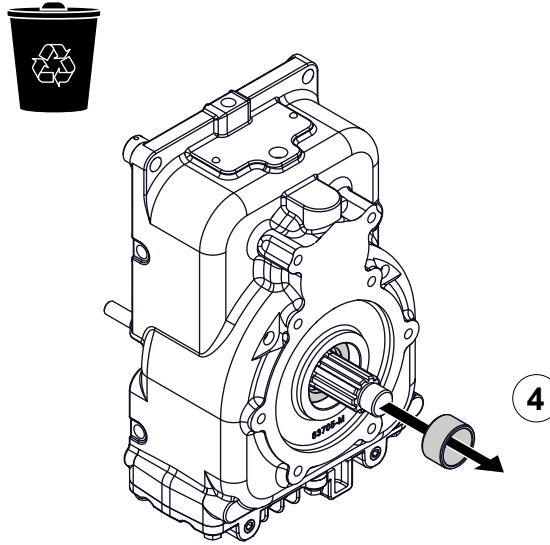
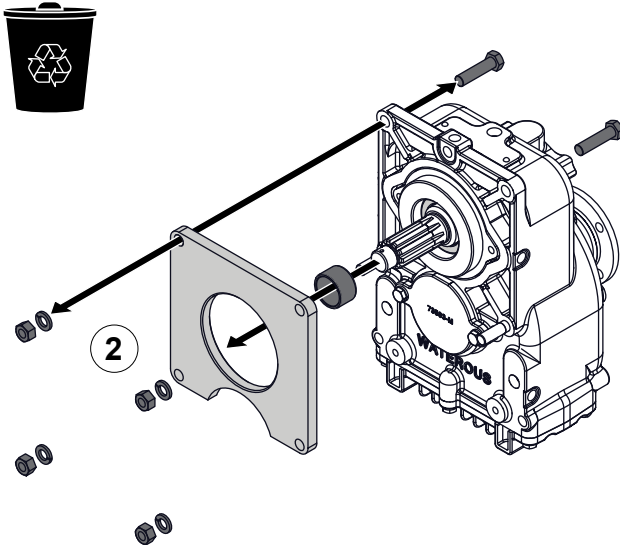

Removing the Bottom Cover

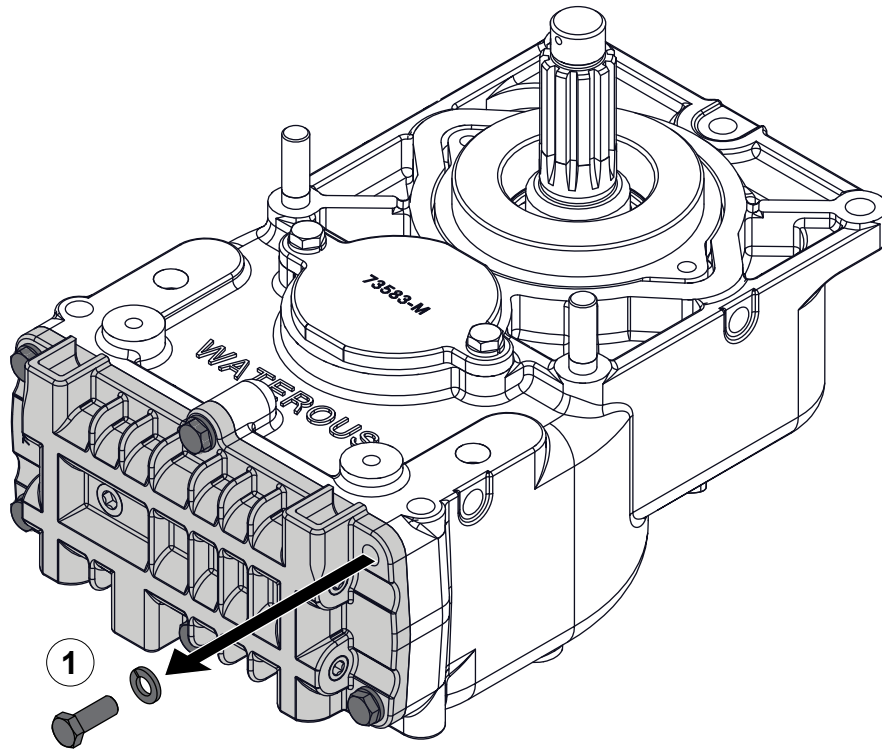

Use the illustrations and instructions to remove the bottom cover.

- 1 Remove and set aside the hardware securing the bottom cover to the case.
- 2 Remove and discard the bottom cover O-ring.

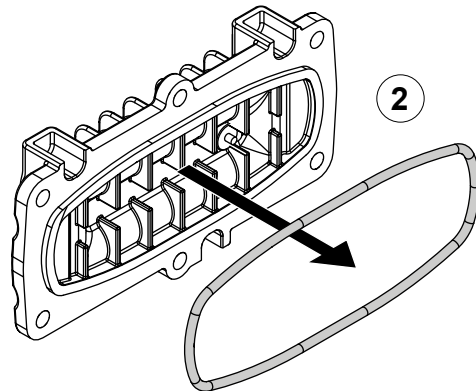

Removing the Drive Components

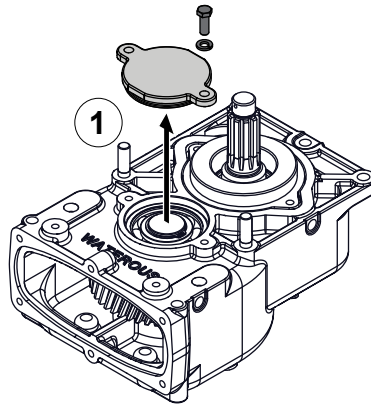

Use the illustrations and instructions to remove the drive components.

- 1 Remove the hardware securing the bearing cover. Remove and discard the bearing cover O-ring. Set aside the bearing cover and hardware.
- 2 Remove the drive shaft and associated components.
- 3 Remove the drive gear and remaining components.

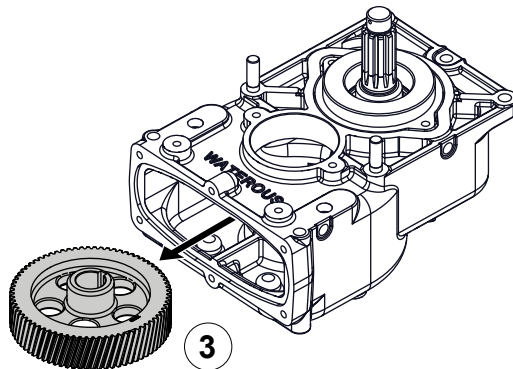
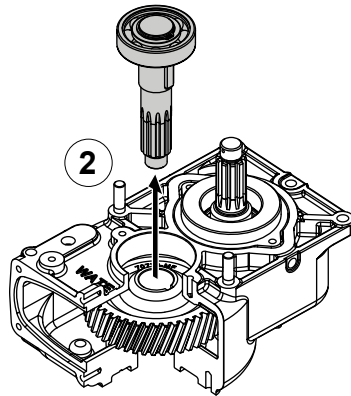

Removing the Bearing Housing

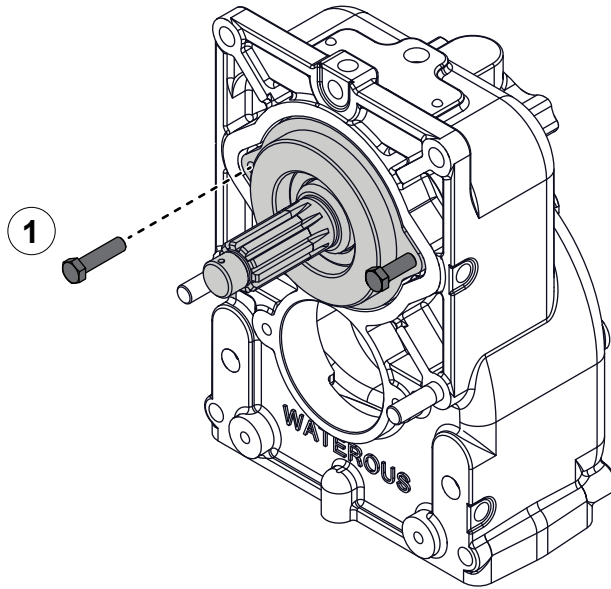

Use the illustrations and instructions to remove the bearing housing.

- 1 Perform the following to remove the bearing housing and the associated components:
 - Locally sourced 2, 3/8-24 x 1-1/2 inches.
 - Install the screws into the jacking-holes.
 - Apply a quarter turn alternatively to each jacking-screw until the bearing housing is free from the case.
- 2 Once you remove the bearing housing and the associated components from the case, perform the following:
 - Remove and discard the O-ring, oil seal, and locknut.
 - Use an arbor press to separate the remaining components.

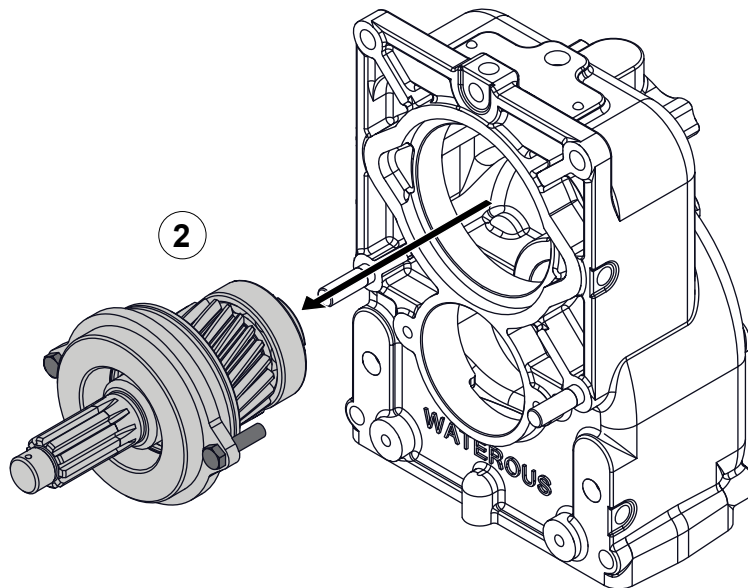

Preparing to Assemble the Power Take-Off

- Read and understand the instructions before assembling the power take-off.
- Prepare a workspace suitable to accommodate and support the power take-off.
- Gather the necessary tools.
- Gather the cleaning cloths, brushes, and fluids.
- Gather the penetrating fluids, lubricants, sealant, and anti-seize.
- Understand that your configuration may require additional steps that are not described in the illustrations or instruction to perform the assembly.
- This equipment is intended to be assembled by a person or persons with the basic knowledge of servicing similar equipment. Contact Waterous with question.

Tools Required

- Typical automotive mechanics hand tools.
- Suitable arbor press.
- Torque wrench capable of 450 ft-lb (610 N·m).
- Suitable support and lifting equipment.

Best Practices

- Remove any dirt, sand, grease, or oil from the enclosure before you begin the overhaul. Surface debris can transfer into the pump interior and prematurely wear internal parts.
- Replace any gaskets and O-ring seals during the assembly.
- Do not reuse the self-locking nuts.
- Apply anti-seize to the self-locking nut threads before installation.

Assembling the Power Take-Off Components

- Refer to the service parts list (SPL) for part identification.
 - Note:** Documents specific to your application are available through the MyWaterous login at Waterousco.com by entering the serial number for your system. Depending on the application, the serial number for your equipment is located on the operator panel, or the pump, or the power take-off, or some combination of the three.
- Use established industry practices to assemble the power take-off.
- Tighten hardware to industry standard torque specification—unless otherwise noted.
- Make sure that you do not over-tighten plugs.
- Install retaining rings with the flat face towards the component you are retaining.
- Replace items such as O-rings, bearings, gaskets, oil seals, lubricants, and locknuts with their equivalent.

Installing the Power Take-Off

Use the information that you recorded when you removed the equipment to install it into the apparatus.

Understanding the Illustrations

The assembly illustrations depict a typical application. Plugs, breathers, cooling hoses and fittings are not illustrated—as they may be in a different location in your application. Refer to the SPL for your application to identify the various plug locations.

Heavy-Duty TK Power Take-Off

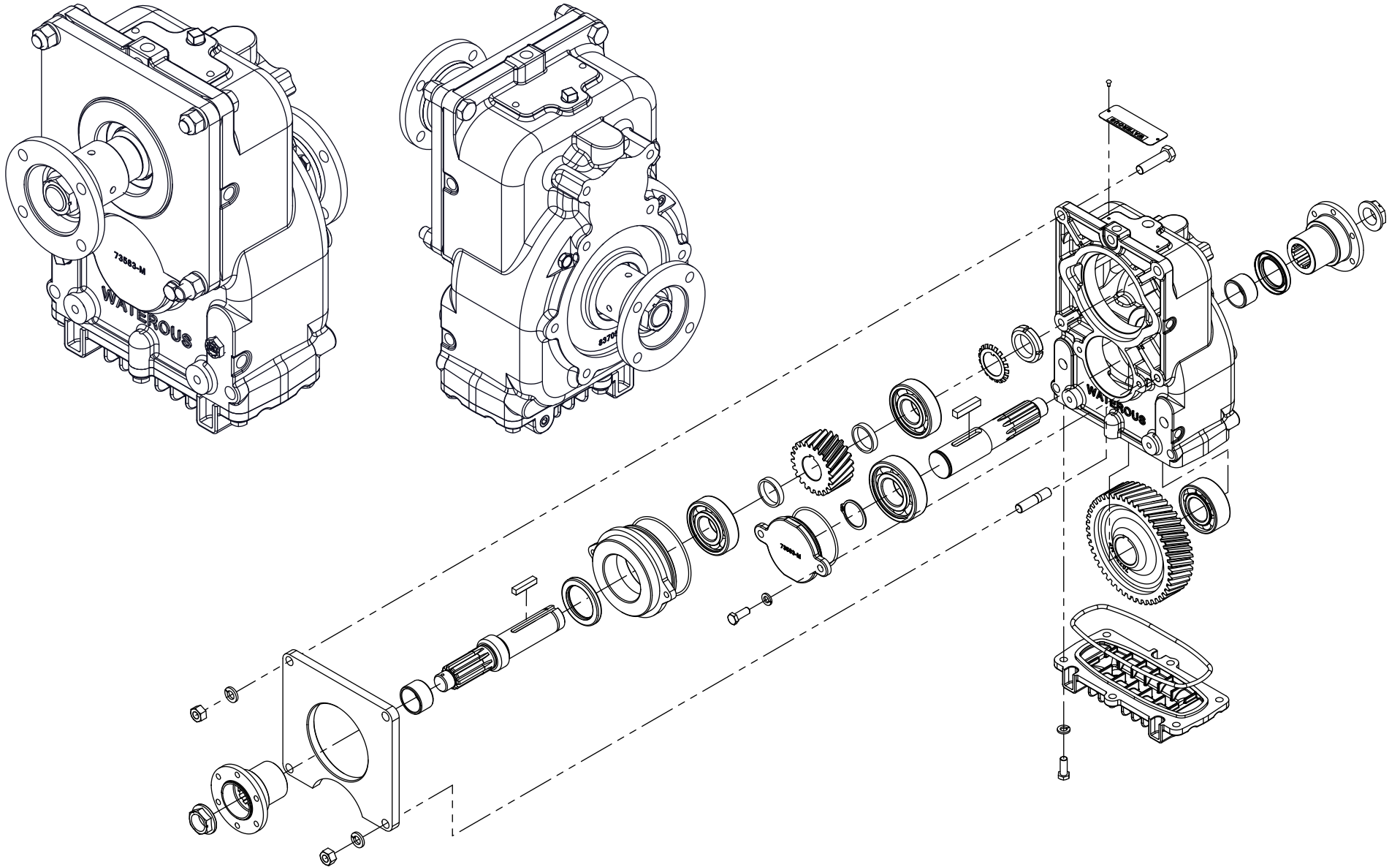

Assembling the Bearing Housing

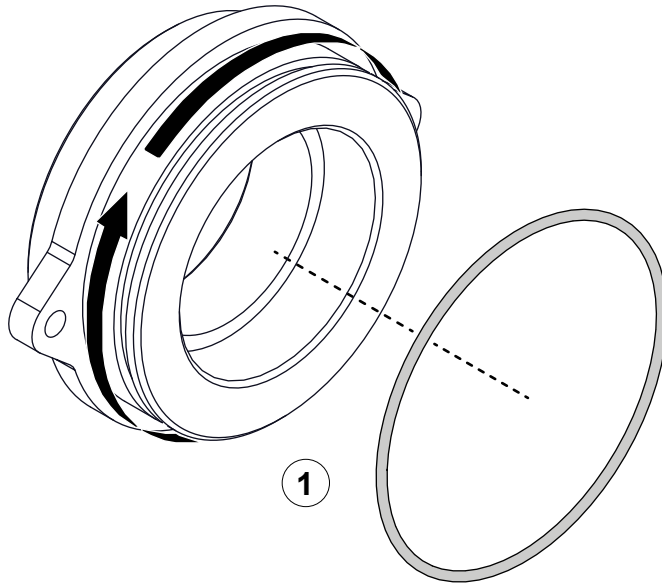

Use the illustrations and instructions to assemble the bearing housing.

- 1 Apply sealant to the O-ring groove and install O-ring around the bearing housing.
- 2 Apply grease to the outer-bearing race and press it into the bearing housing.

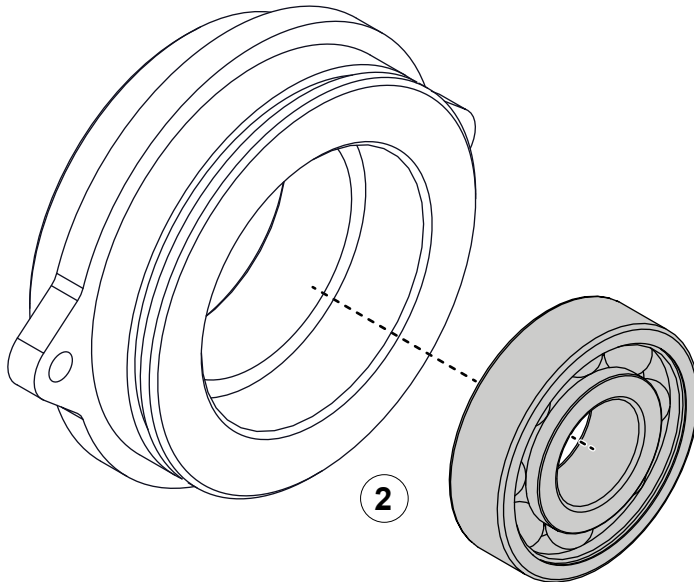
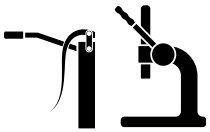

Assembling the Impeller Shaft

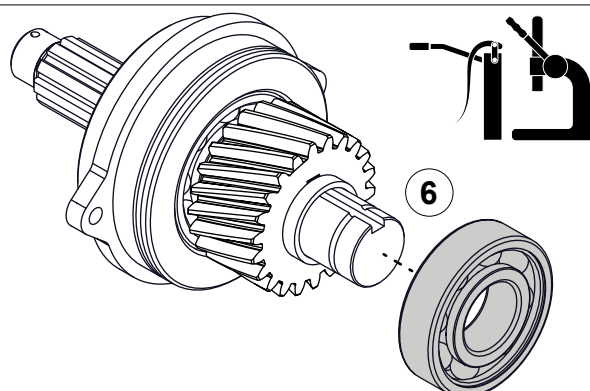
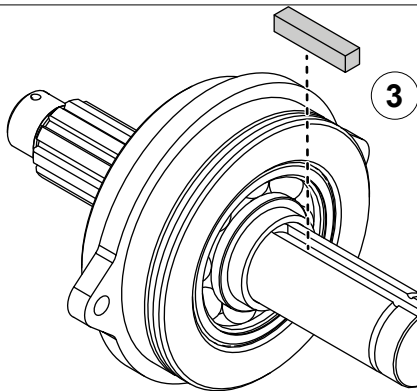
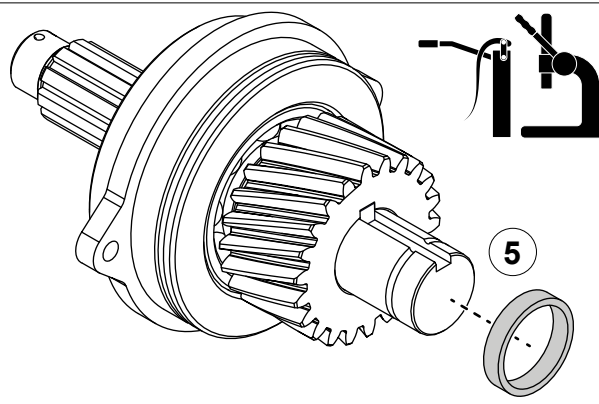
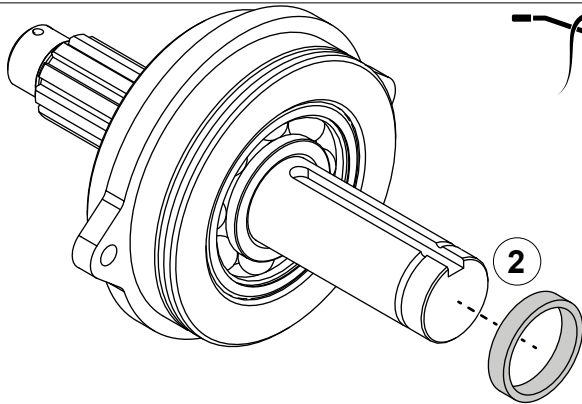
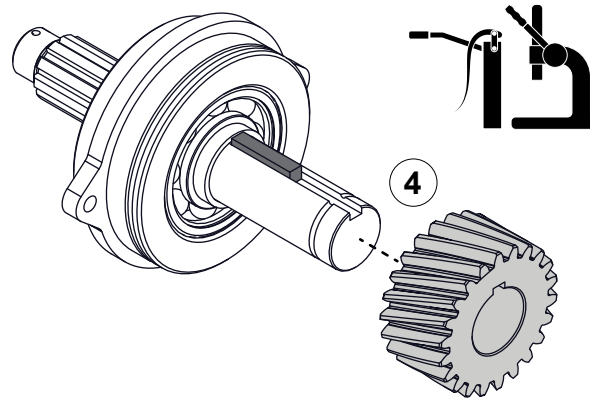
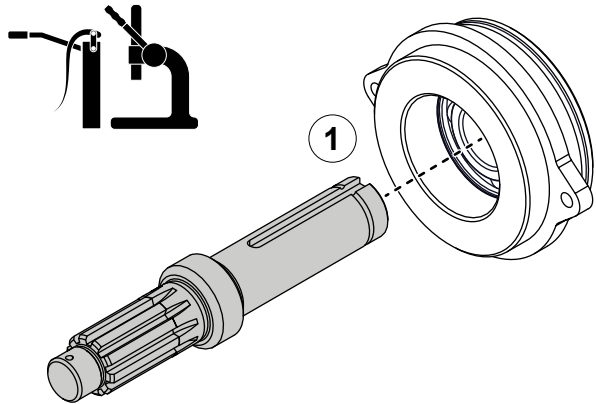

Use the illustrations and instructions to assemble the impeller shaft.

- 1 Apply grease to the inner-bearing race and press the shaft into the bearing-housing assembly.
- 2 Apply grease to the shaft and install the spacer.
- 3 Install the key into the keyway.
- 4 Apply grease to the shaft and align the driven gear to the key on the shaft. Press the components together.
- 5 Apply grease to the shaft and install the spacer.
- 6 Apply grease to the inner-bearing race and press the bearing to the impeller-shaft assembly.

Assembling the Impeller Shaft

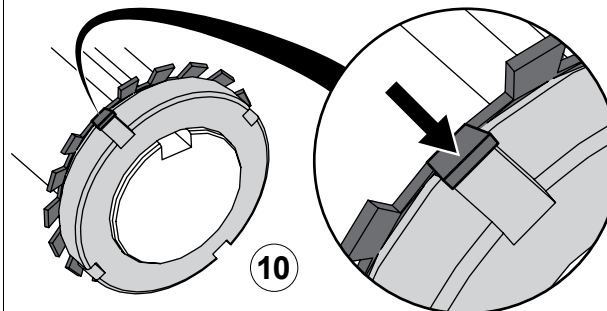
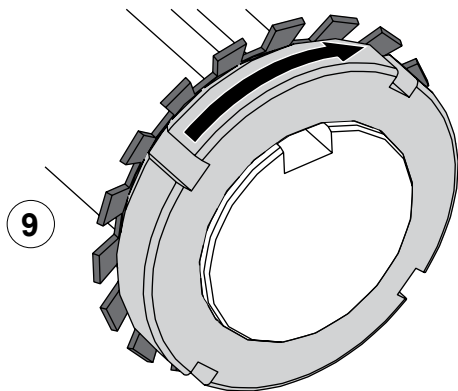
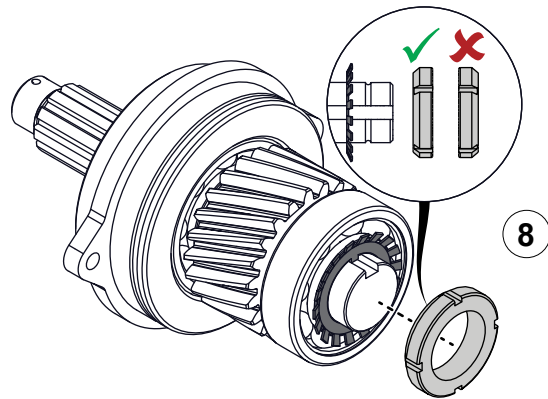
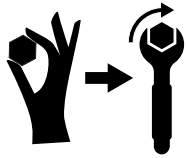
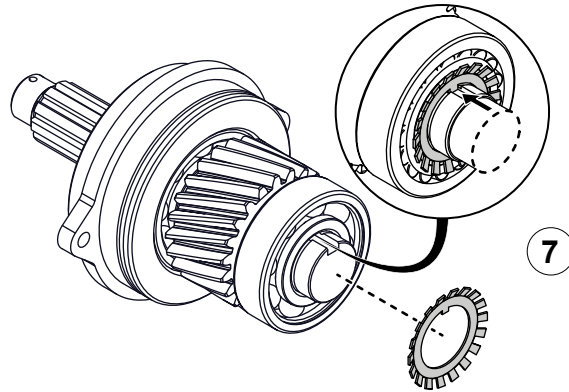

Use the illustrations and instructions to complete the assembly.

- 7 Install the bearing-lock washer inner tab into the keyway on the shaft.
- 8 Install the bearing-lock nut to the shaft—finger tight and then an additional 1/4 turn.
- 9 Thread the bearing locknut onto the impeller shaft until it contacts the bearing-lock washer. Apply a minimum of a quarter turn. Then continue turning until a tab on the bearing-lock washer aligns with a notch on the bearing-lock nut.
- 10 Fold the tab into the notch to lock the bearing locknut into place.

Installing the Impeller-Shaft

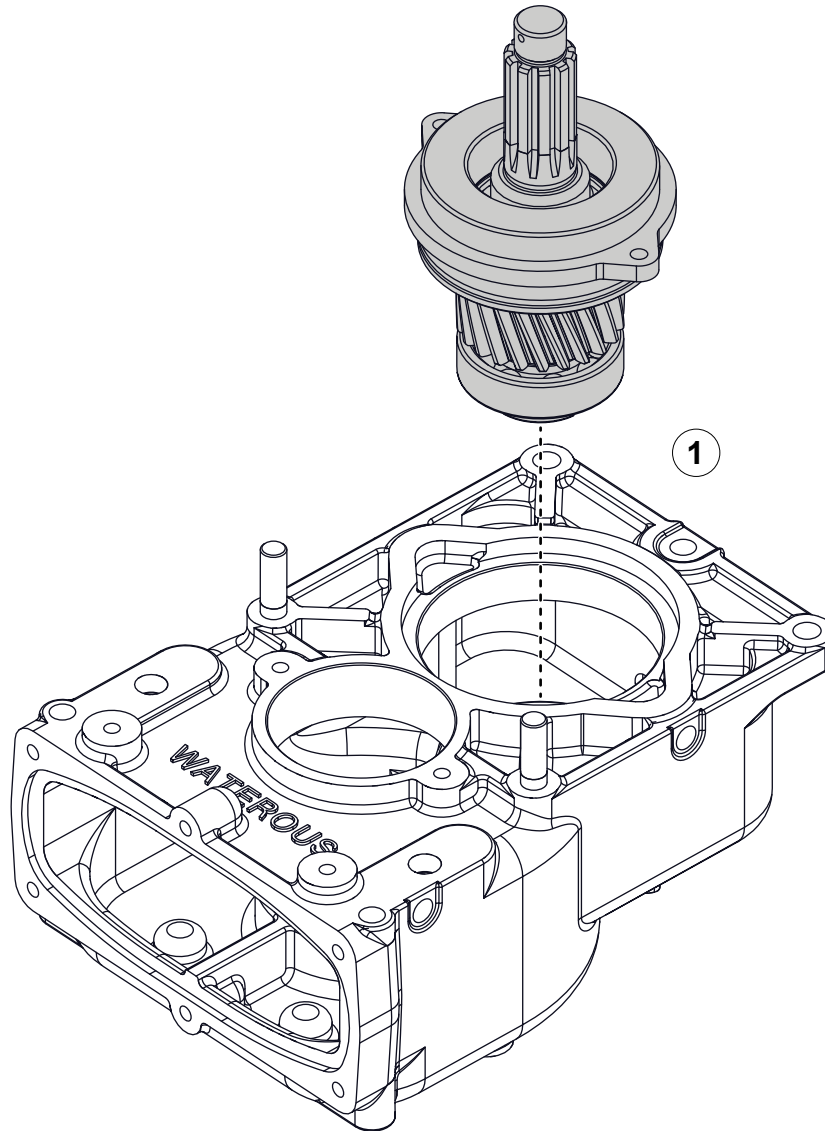
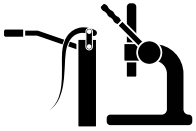

Use the illustration and instruction to install the impeller-shaft assembly.

- 1 Apply grease to the outer-bearing race and press the impeller-shaft assembly into the case.

Assembling the Drive Shaft

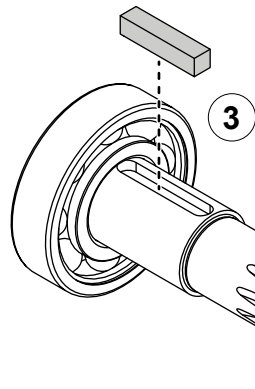
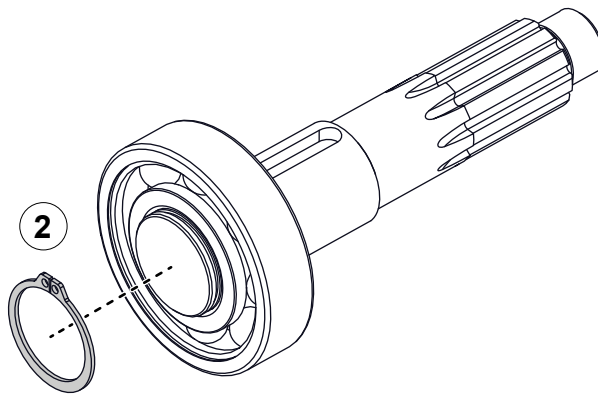
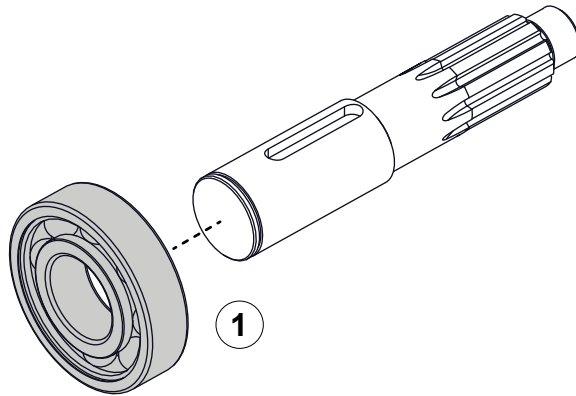
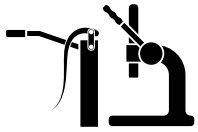

Use the illustrations and instructions to assemble the drive-shaft assembly.

- 1 Apply grease to the inner-bearing race and press the drive shaft and bearing together.
Note: Press the bearing onto the shaft until it is flush with the retaining-ring groove.
- 2 Install the retaining ring.
- 3 Install the key into the keyway.

Installing the Drive-Gear Components

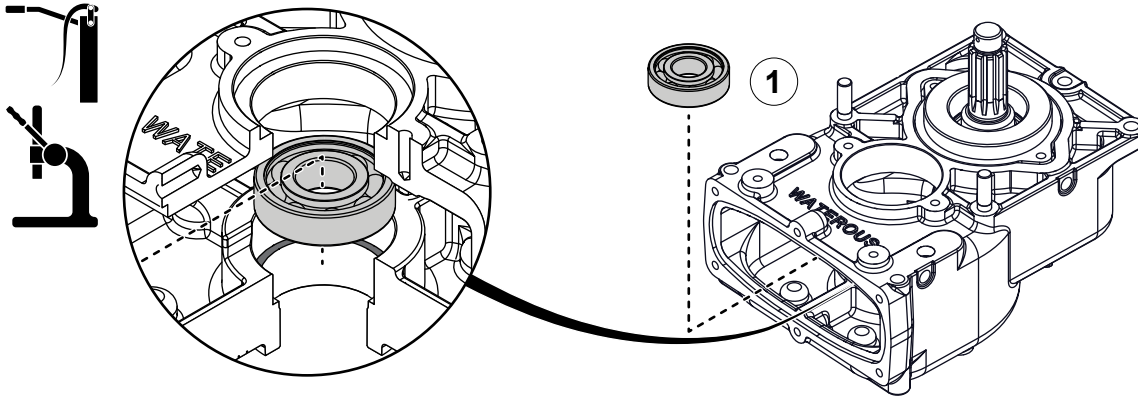

Use the illustrations and instructions to install the drive-gear components.

- 1 Apply grease to the outer-bearing race and press it into bearing pocket inside the case.
- 2 Align the drive gear over the bearing.
- 3 Apply grease to the drive shaft. Align the key on the drive shaft to the keyway on the drive gear and press the assembly together.

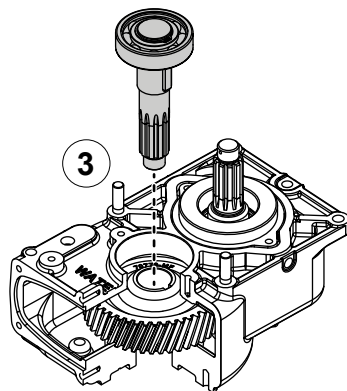
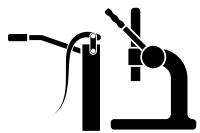
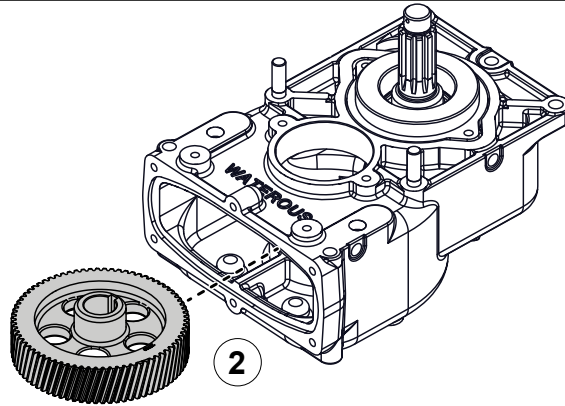

Installing the Bearing Cover

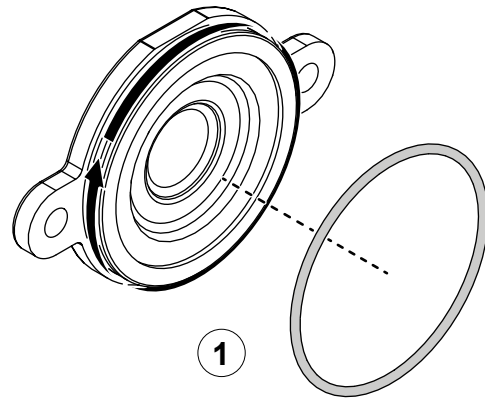

Use the illustrations and instructions to install the bearing cover.

- 1 Apply sealant to the O-ring groove and install the O-ring around the bearing cover.
- 2 Use the hardware that you removed earlier to securely install the bearing cover.

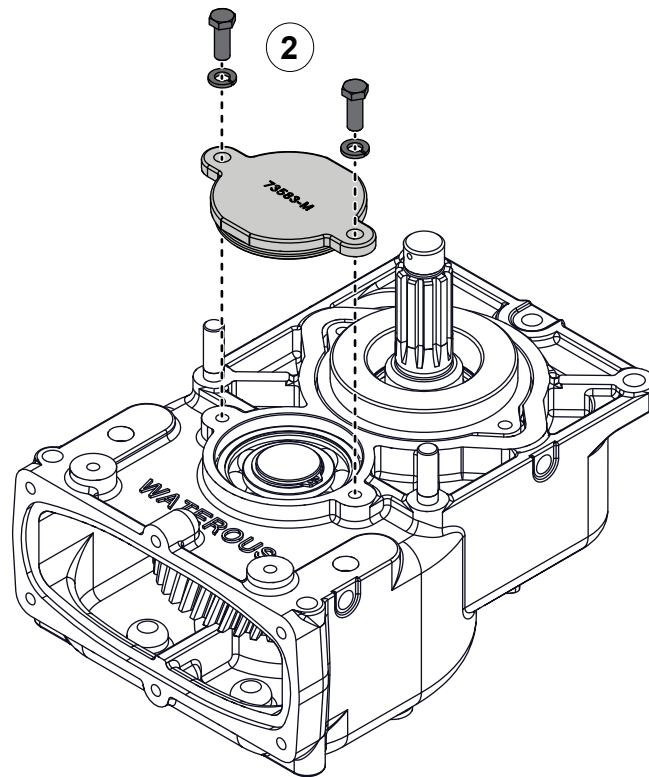

Installing the Bottom Cover

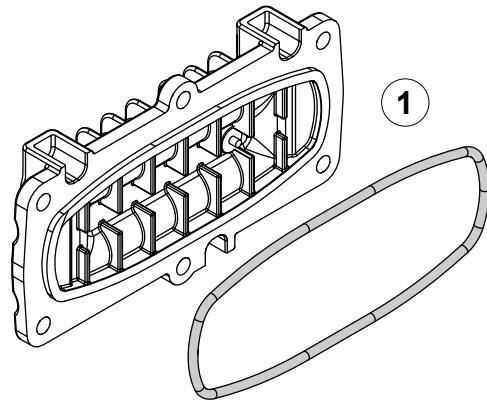

Use the illustrations and instructions to install the bottom cover.

Note: Refer to the SPL for your application to determine the bottom cover orientation.

- 1 Apply sealant around the O-ring and install the O-ring on the bottom cover.
- 2 Use the hardware that you removed earlier to securely install the bottom cover.

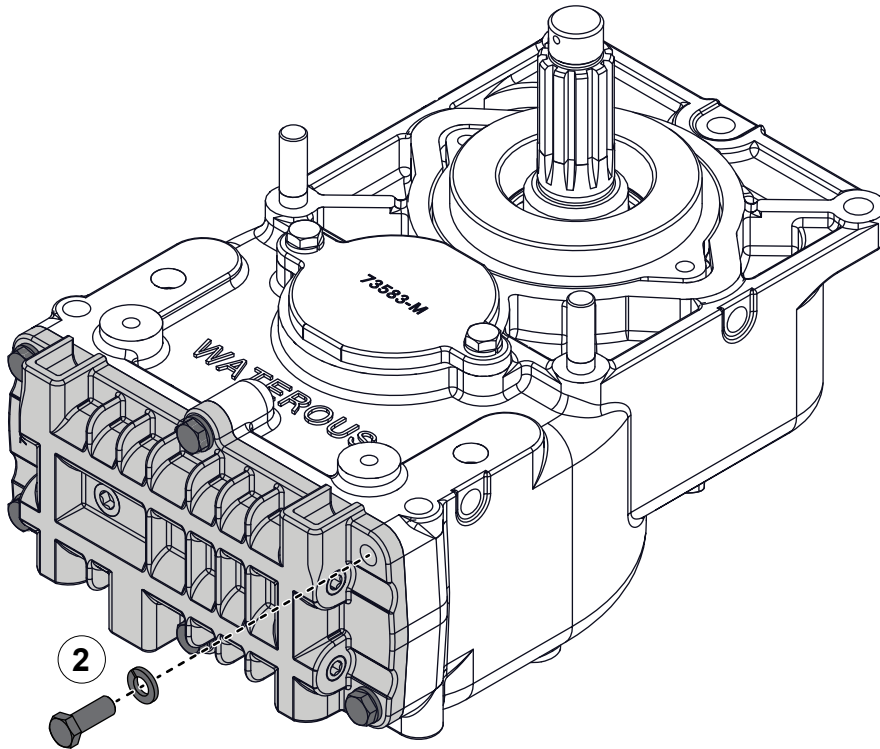

Installing the Drive-Shaft Components and Rear Adapter

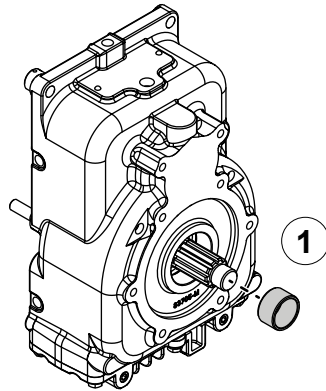

Use the illustrations and instructions to install the drive-shaft components.

- 1 Apply grease to the spacer and install it over the drive shaft.
- 2 Apply sealant to the seal and install it over the drive shaft.
- 3 Install the adapter and adapter nut provided by Waterous. Torque the nut to 400–450 ft-lb (542–610 N·m).

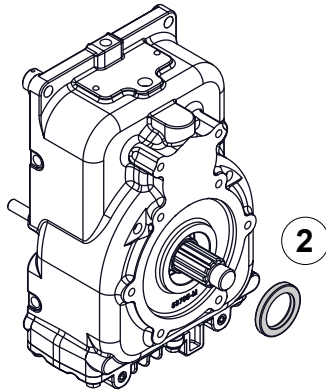

Note: If you are installing an adapter not provided by Waterous, refer to the manufacturer's installation instructions. Contact the adapter manufacturer for more information.

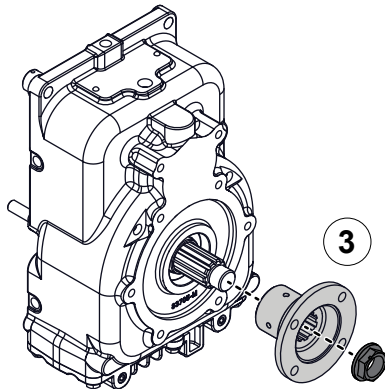

Installing the Impeller Shaft Components and Front Adapter

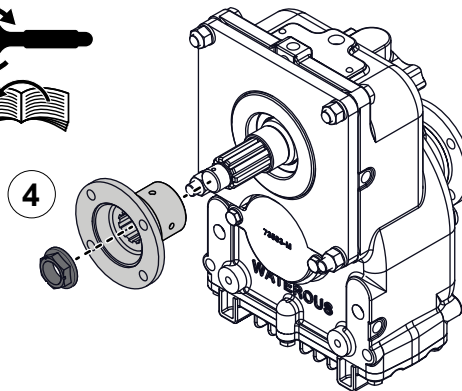
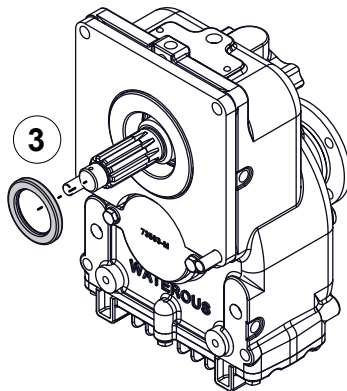
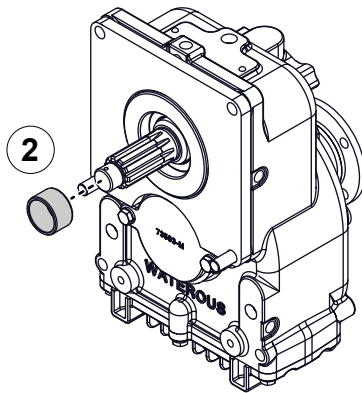
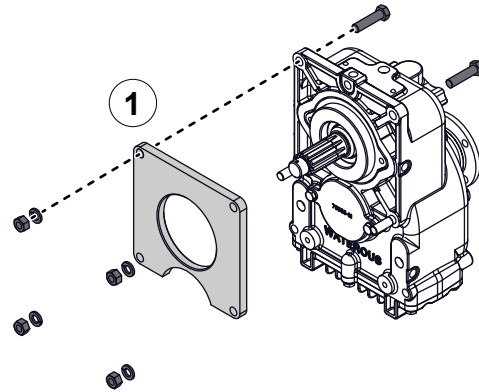

Use the illustrations and instructions to install the impeller-shaft components.

- 1 Use the hardware that you set aside earlier to secure install the adapter.
- 2 Apply grease to the spacer and install it over the output shaft.
- 3 Apply sealant to the seal and install it over the output shaft.
- 4 Install the adapter and adapter nut provided by Waterous. Torque the nut to 400–450 ft-lb (542–610 N·m).

Note: If you are installing an adapter not provided by Waterous, refer to the manufacturer's installation instructions. Contact the adapter manufacturer for more information.

Adding Oil to the Power Take-Off

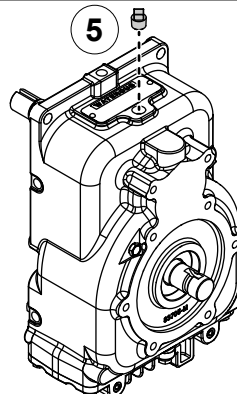
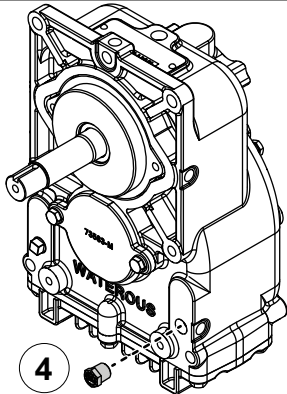
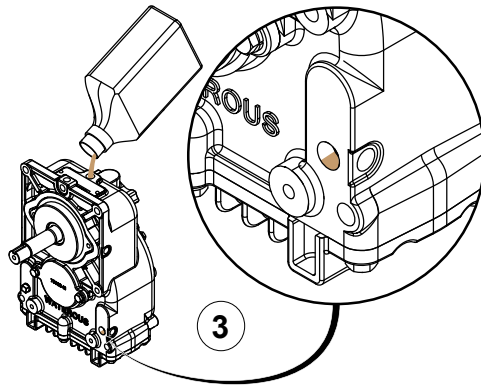
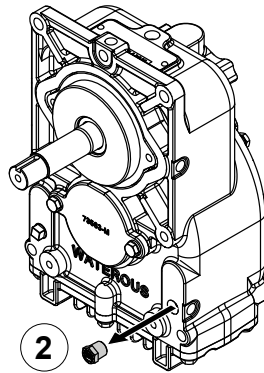
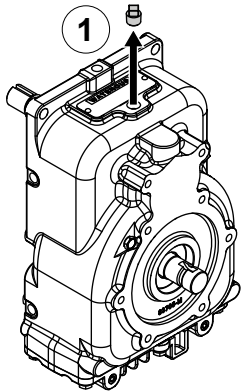

Use the illustrations and instructions to add oil to the power take-off. The illustrations may not represent your specific power take-off orientation. Refer to the SPL for your application to locate the oil-fill and oil level plug for your orientation.

Refer to the documentation provided with your equipment to determine the type of lubricant, and the amount, for your application. Contact Waterous for more information.

- 1 Remove and set aside the oil-fill plug.
- 2 Remove and set aside the oil-level plug.
- 3 Add lubricant to the power take-off.
Note: After pouring some oil into the case, allow it to settle before adding more to avoid over filling.
- 4 Securely install the oil-level plug.
- 5 Securely install the oil-fill plug.



Waterous Company
125 Hardman Avenue South
South Saint Paul, MN 55075
(651) 450-5000
www.waterousco.com