

# WATEROUS

Form Number: F-2939

Issue Date: Jun 9, 2022

Revision Date: Dec 13, 2024

## VENTURIS™ Air Primer System

### Installation, Operation, and Maintenance

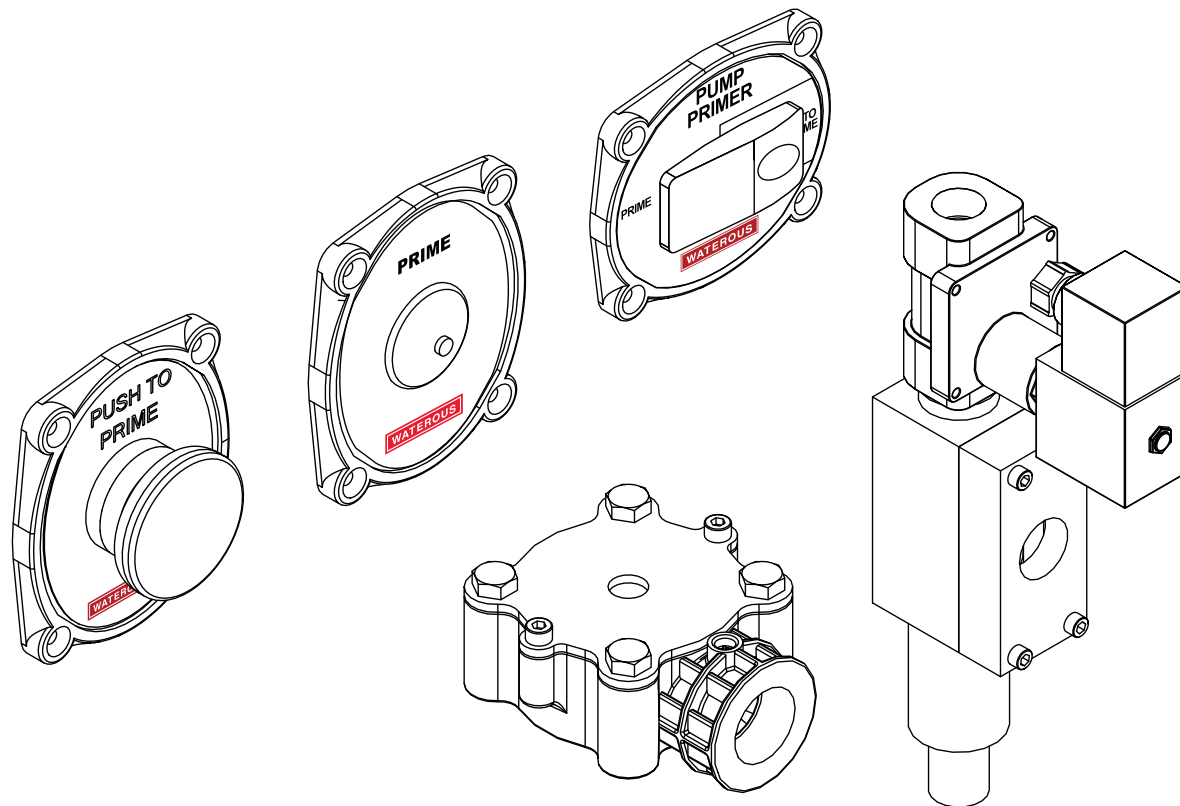

Waterous Company • 125 Hardman Avenue South • South Saint Paul, MN 55075 • (651) 450-5000

[www.waterousco.com](http://www.waterousco.com)



# Table of Contents

---

|  |           |   |           |
|--|-----------|---|-----------|
| <b>Safety</b>                                  | <b>4</b>  | Auto-Prime Switch Cutout Dimensions               | 34        |
| Safety Precautions                             | 4         | Standard Push Button Switch Cutout Dimensions     | 35        |
| <b>Introduction</b>                            | <b>5</b>  | Oversized Push Button Switch Cutout Dimensions    | 36        |
| Using this Document                            | 5         | Air Primer Mounting Dimensions                    | 37        |
| Viewing the Document Electronically            | 5         | Pressure Protection Valve Mounting Dimensions     | 38        |
| Printing the Document                          | 5         | Installing the Auto-Prime Switch                  | 39        |
| Additional Documentation                       | 5         | Panel Cutout and Mounting Holes                   | 39        |
| <b>Overview</b>                                | <b>7</b>  | Positioning the Switch                            | 40        |
| Panel Switch with Single Priming Valve         | 7         | Mounting the Enclosure                            | 41        |
| Standard Push Button System                    | 8         | Mounting the Panel                                | 42        |
| Oversized Push Button System                   | 10        | Installing the Standard Push Button Switch        | 43        |
| Auto-Prime System                              | 12        | Installing the Oversized Push Button Switch       | 44        |
| Auto-Prime with Additional Panel Switch System | 14        | Installing the Priming Valve                      | 45        |
| Multiple Priming Valve System                  | 16        | Installing the Pressure Switch                    | 46        |
| Auto-Prime Switch                              | 18        | Installing the Air Primer—Remote Mounting         | 47        |
| Standard Push Button Switch                    | 20        | Installing the Pressure Protection Valve—Optional | 48        |
| Oversized Push Button Switch                   | 21        | Installing the Priming Valve Solenoid—Optional    | 49        |
| Venturis Air Primer                            | 22        | Connecting the Vacuum Components                  | 50        |
| Priming Valve                                  | 23        | Connecting the Components                         | 51        |
| Pressure Protection Valve                      | 24        | Auto-Prime Switch                                 | 51        |
| Pressure Switch                                | 25        | Standard Push Button Switch                       | 52        |
| Priming Valve Solenoid                         | 26        | Oversized Push Button Switch                      | 53        |
| Priming Valve Solenoid Extension Cable         | 27        | Mixed Switches with Priming Valve Solenoids       | 54        |
| Pressure Switch Extension Cable                | 28        | Standard Switches with Priming Valve Solenoids    | 55        |
| Air Primer Extension Cable—Optional            | 29        | Additional Field Wired Cable                      | 56        |
| Oversized Push Button Y-Splitter               | 30        | <b>Operation</b>                                  | <b>57</b> |
| <b>Installation</b>                            | <b>32</b> | Basic Operation Overview                          | 57        |
| Installation Overview                          | 32        | Venturis Air Primer Operation Overview            | 58        |
| Determining Cable and Wire Routing             | 32        | Auto-Prime Switch Priming                         | 59        |
| Preparing for the Installation                 | 32        | Standard Switch Priming                           | 60        |
| Optional Equipment                             | 32        | Priming Multiple Locations                        | 61        |
| Tubing Requirements                            | 32        | <b>Maintenance</b>                                | <b>62</b> |
| Vacuum Tubing                                  | 32        | Maintenance Schedule                              | 62        |
| Compressed Air Tubing                          | 32        | Service Tool—Secondary Nozzle Removal Tool        | 63        |
| Compressor Requirement                         | 32        | Servicing the Vacuum Pump                         | 64        |
| Symbols  | 32        | Removing Components                               | 64        |
| Determining the Installation Requirements      | 33        | Installing Components                             | 66        |
| Installation Requirements                      | 33        |   |           |

## Safety Precautions

- Read and understand all the associated documentation before you begin the installation.
- Read and understand all the notices and safety precautions.
- Be aware that these instructions are only guidelines and are not meant to be definitive. Contact Waterous when you have questions about installing, operating, or maintaining the equipment.
- Do not install the equipment if you are not familiar with the tools and skills needed to safely perform the required procedures—proper installation is the responsibility of the purchaser.
- Do not operate the equipment when safety guards are removed.
- Do not modify the equipment.
- Regularly check for leaks and worn or deteriorated parts.

# NOTICE

## Before Operation

- **Read and understand all the instructions provided.**
- **Check all fluid levels and replenish if necessary.**
- **Remove all shipping plugs and install the operation plugs or caps.**



Use this document to install and operate your Waterous equipment. Understand the following conditions before continuing with the document:

- The instructions may refer to options or equipment that you may not have purchased with your system.
- The illustrations in this document are intended to convey concepts. Do not use the illustrations to determine physical attributes, placement, or proportion.
- Understand that your application may require additional steps, that are not described in the illustrations or instructions, to perform the installation.
- Any equipment described in this document is intended to be installed by a person or persons with the necessary skills and knowledge to perform the installation.
- Any equipment described in this document is intended to be operated by a person or persons with the basic knowledge of operating similar equipment.
- Do not install the equipment if you are not familiar with the tools and skills needed to safely perform required procedures—proper installation is the responsibility of the purchaser.

This document is divided into the following sections:

### SAFETY

This section describes general precautions and alert symbols in the document.

### INTRODUCTION

This section is an overview of the document.

### OVERVIEW

This section describes the components that make up the system.

### INSTALLATION

This section describes the installation and initial setup procedures.

### OPERATION

This section describes the equipment operation.

### MAINTENANCE

This section describes maintaining the equipment.

## Using this Document

Use the guidelines below when viewing this document.

### Viewing the Document Electronically

- View this document in landscape orientation.
- Use the table of contents to navigate directly to that section.
- Text **with this appearance** is linked to a reference.

### Printing the Document

- This document is designed to be printed on both sides and in color.
- Use a 3-ring binder to view and store this document.

## Additional Documentation

Additional documentation is available through the MyWaterous login at [Waterousco.com](http://Waterousco.com). Use your serial number to gain access to the service parts list associated with your system. Dimensional drawings are available through the Waterous Service department.



## Panel Switch with Single Priming Valve

There are 3 panel switch options available that operate the priming system.

### Auto-Prime Switch

Auto-prime with integrated push-to-prime operation.

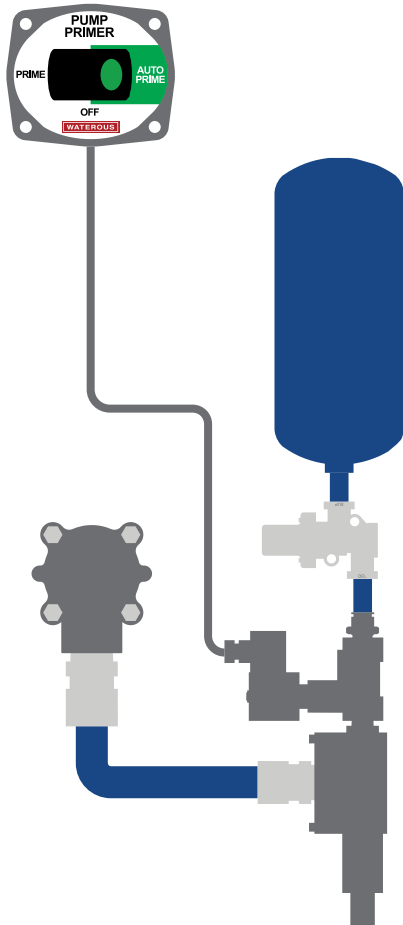

### Standard Push Button Switch

Standard push-to-prime switch.

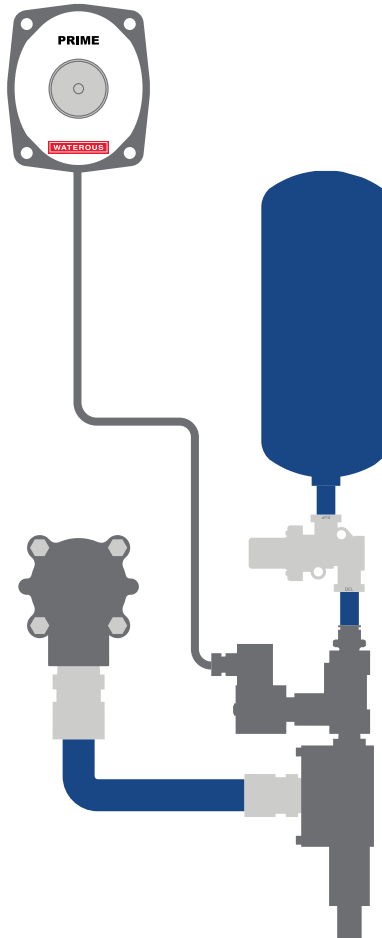

### Oversized Push Button Switch

Larger button push-to-prime switch preferred by some operators.

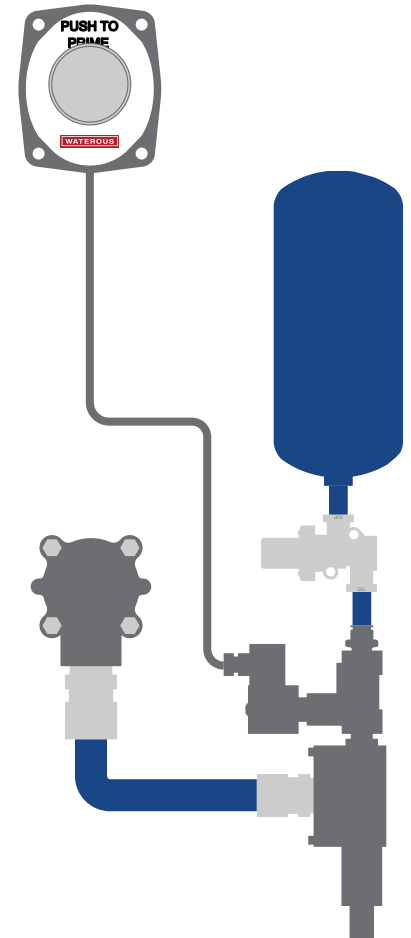

## Standard Push Button System

The Venturis air primer system uses the on-board air supply to create a vacuum to prime the fire pump. The basic system consists of a Venturis air primer, a priming valve, a standard push button switch, and a compressed air supply equipped with a pressure protection valve. Additional components, or a combination of components, allow you to operate the system from multiple locations and prime multiple locations individually or simultaneously.

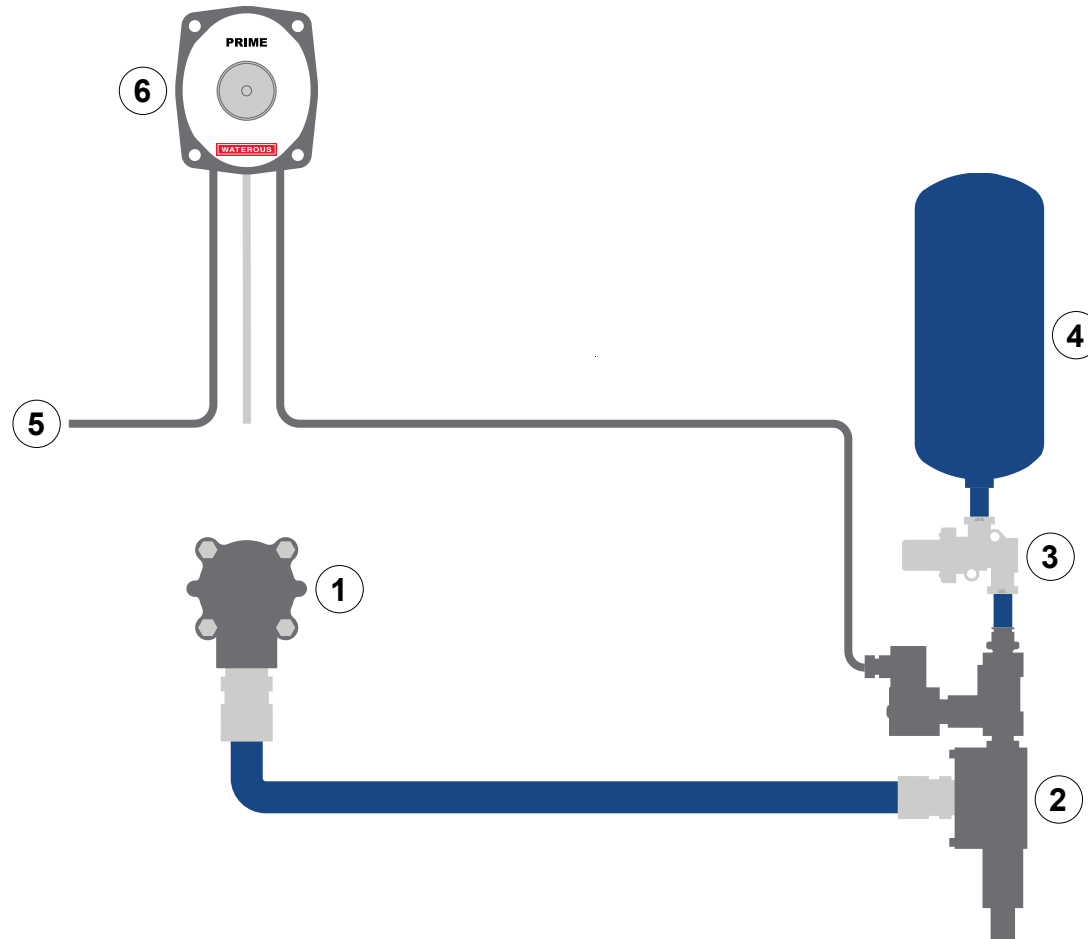



## Standard Push Button System

---

| Feature                       | Description  |
|-------------------------------|--|
| 1 Priming valve               | This allows air to evacuate the pump.                |
| 2 Venturis air primer         | This generates the vacuum.                           |
| 3 Pressure protection valve   | This maintains a reserve air-pressure in the system. |
| 4 On-board air supply         | This supplies compressed air to various systems.     |
| 5 Power                       | This connects to apparatus power.                    |
| 6 Standard push button switch | This operates the priming system.                    |

## Oversized Push Button System

The oversized push button option consists of a panel switch with a larger style button in addition to the base priming components.

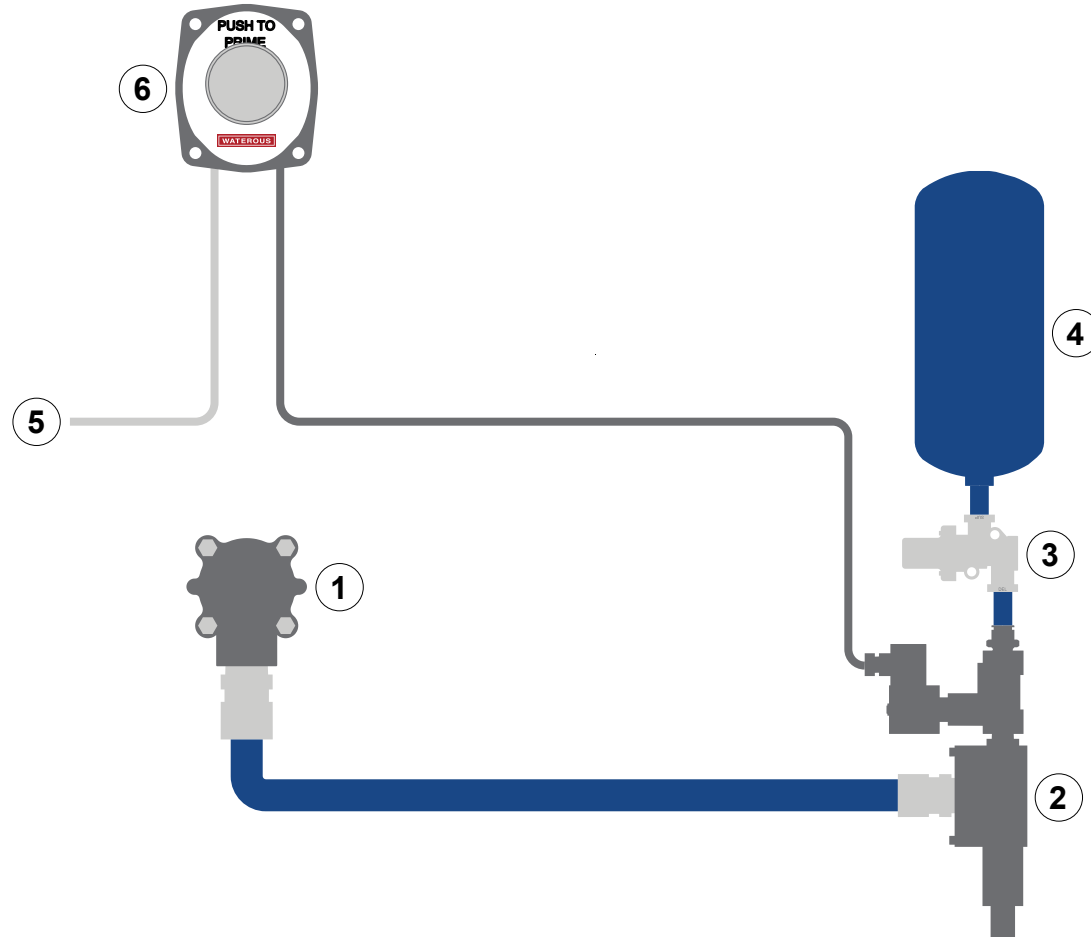

## Oversized Push Button System

---

| Feature                        | Description  |
|--------------------------------|--|
| 1 Priming valve                | This allows air to evacuate the pump.                |
| 2 Venturis air primer          | This generates the vacuum.                           |
| 3 Pressure protection valve    | This maintains a reserve air-pressure in the system. |
| 4 On-board air supply          | This supplies compressed air to various systems.     |
| 5 Power                        | This connects to apparatus power.                    |
| 6 Oversized push button switch | This operates the priming system.                    |

## Auto-Prime System

The auto-prime option consists of an auto-prime switch and a pressure switch in addition to the base priming components. In addition to automatic priming, the switch allows you to manually prime the fire pump.

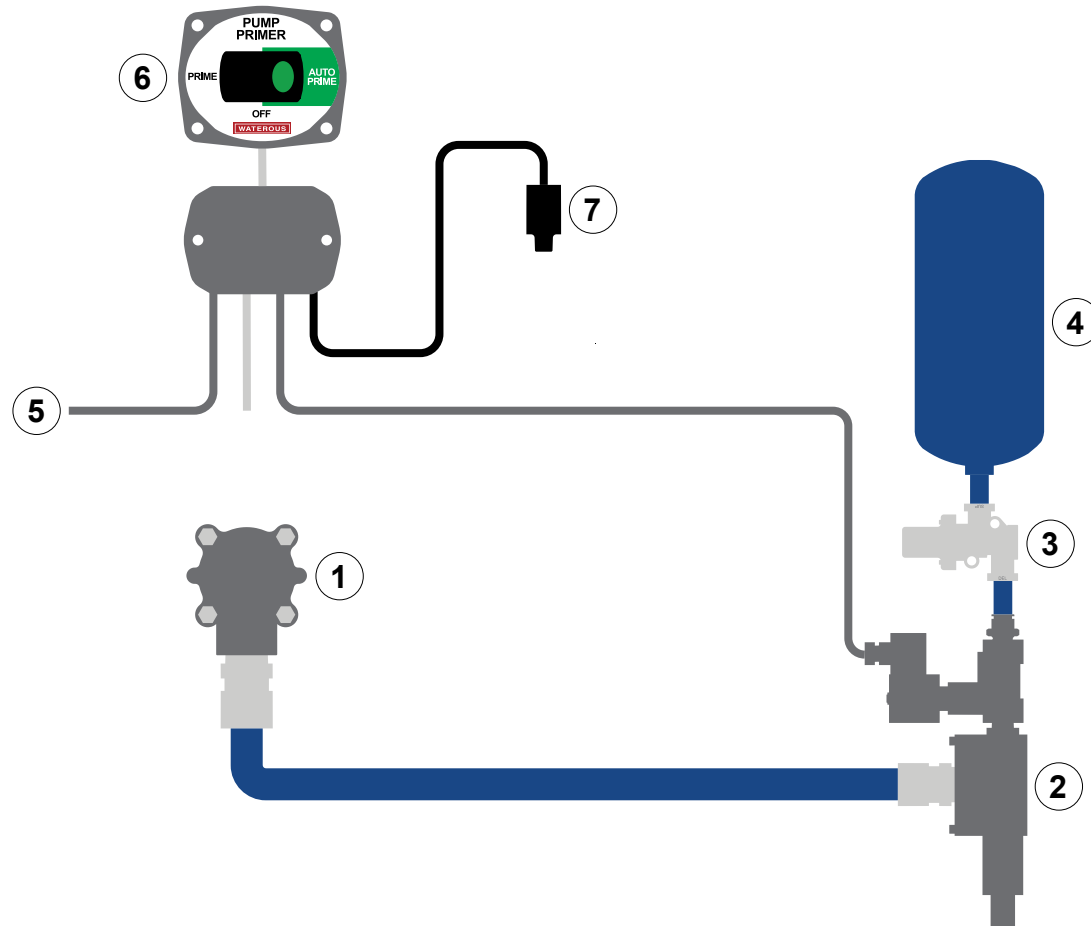

## Auto-Prime System

---

| Feature                     | Description  |
|-----------------------------|--|
| 1 Priming valve             | This allows air to evacuate the pump.                |
| 2 Venturis air primer       | This generates the vacuum.                           |
| 3 Pressure protection valve | This maintains a reserve air-pressure in the system. |
| 4 On-board air supply       | This supplies compressed air to various systems.     |
| 5 Power                     | This connects to apparatus power.                    |
| 6 Auto-prime switch         | This operates the priming system.                    |
| 7 Pressure switch           | This starts and stops the auto-prime operation.      |

## Auto-Prime with Additional Panel Switch System

The Venturis air primer system is configurable to include up to 6 priming valves.

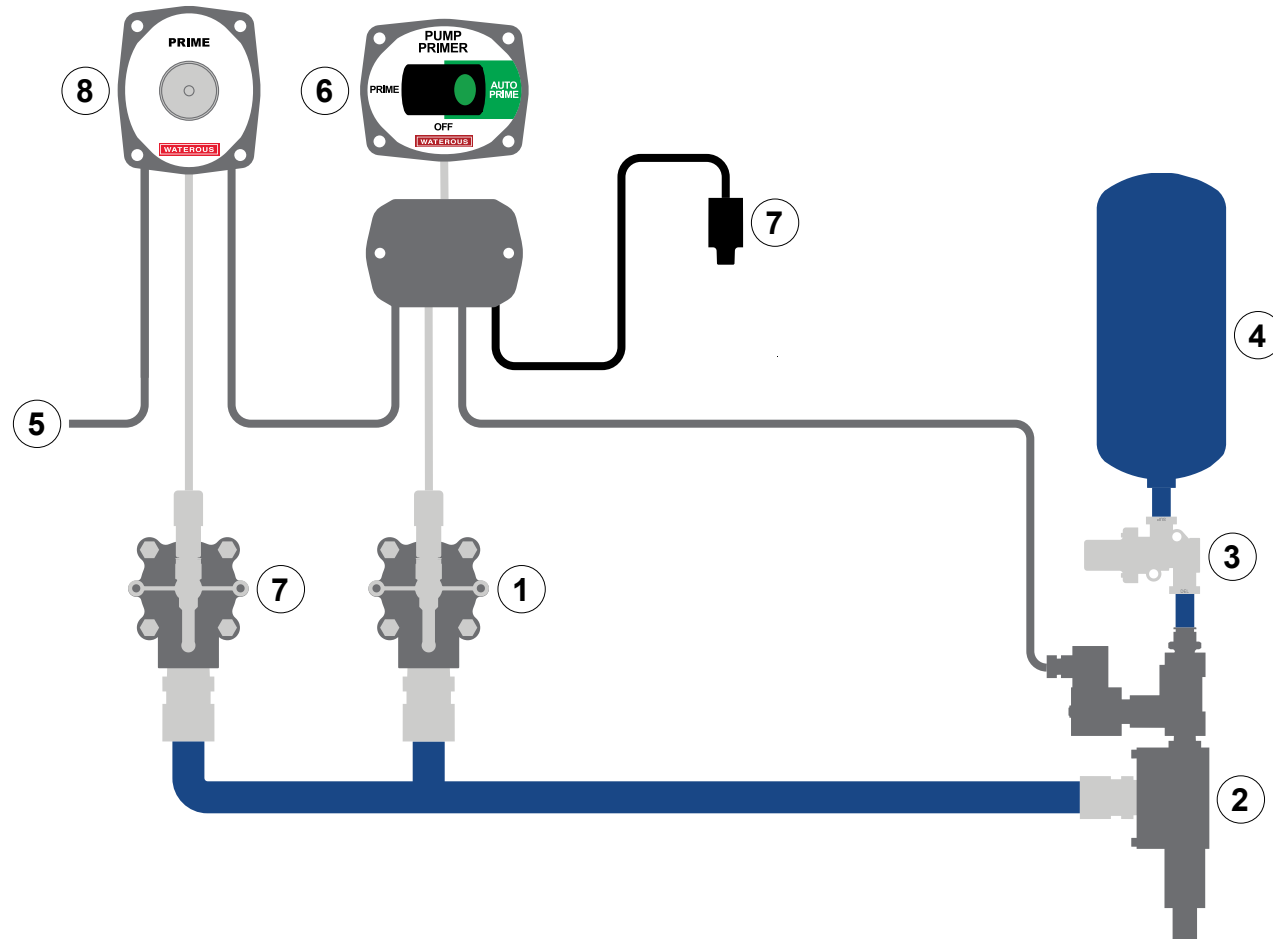

## Auto-Prime with Additional Panel Switch System

---

| Feature                     | Description  |
|-----------------------------|--|
| 1 Priming valve             | This allows air to evacuate the pump.                |
| 2 Venturis air primer       | This generates the vacuum.                           |
| 3 Pressure protection valve | This maintains a reserve air-pressure in the system. |
| 4 On-board air supply       | This supplies compressed air to various systems.     |
| 5 Power                     | This connects to apparatus power.                    |
| 6 Auto-prime switch         | This operates the priming system.                    |
| 7 Pressure switch           | This starts and stops the auto-prime operation.      |
| 8 Additional priming valve  | This operates an additional dedicated priming point. |
| 9 Additional panel switch   | This operates an additional priming valve.           |

## Multiple Priming Valve System

The Venturis air primer system is configurable to include up to 6 priming valves.

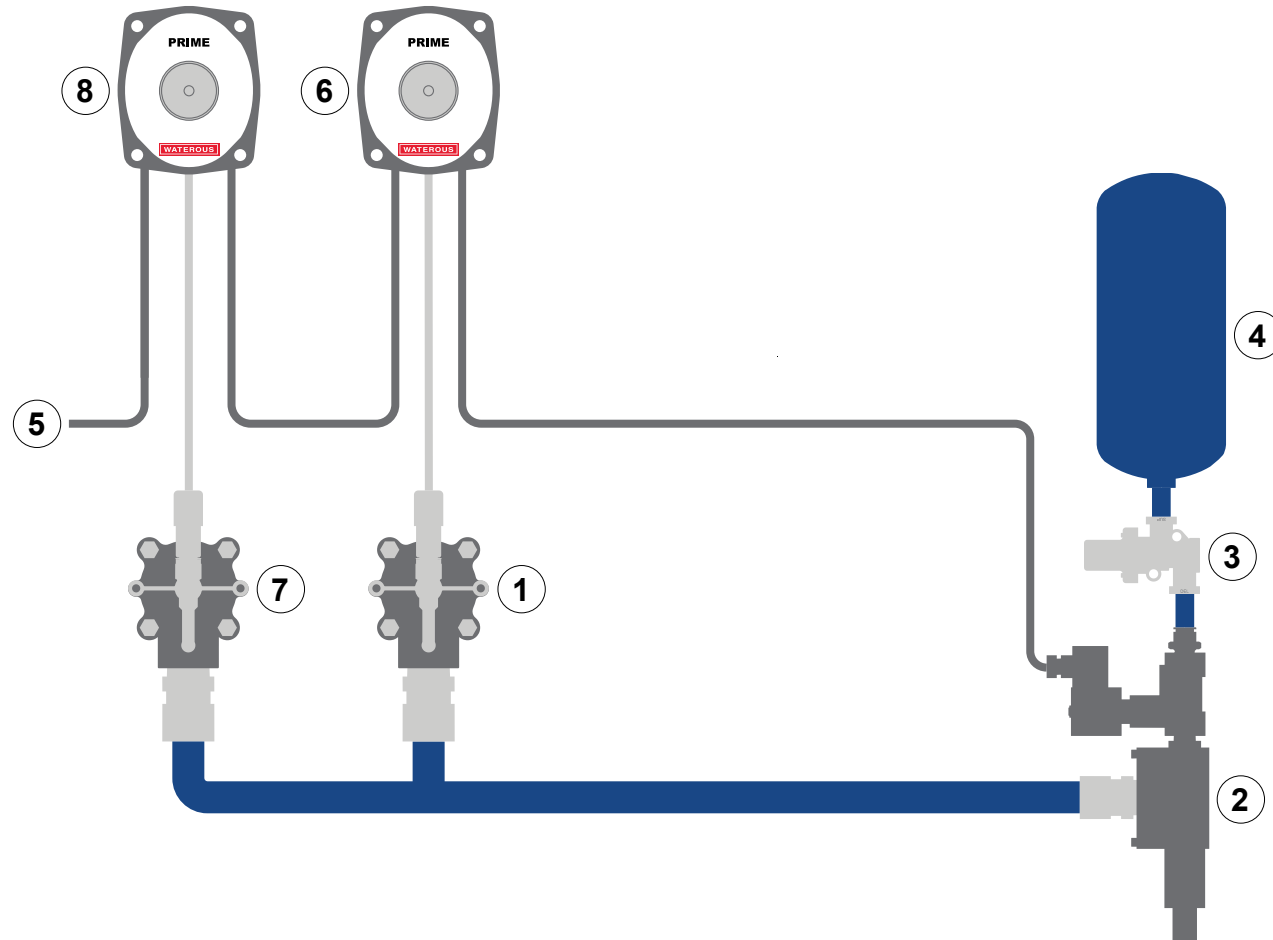



## Multiple Priming Valve System

---

| Feature                       | Description  |
|-------------------------------|--|
| 1 Priming valve               | This allows air to evacuate the pump.                |
| 2 Venturis air primer         | This generates the vacuum.                           |
| 3 Pressure protection valve   | This maintains a reserve air-pressure in the system. |
| 4 On-board air supply         | This supplies compressed air to various systems.     |
| 5 Power                       | This connects to apparatus power.                    |
| 6 Standard push button switch | This operates the priming system.                    |
| 7 Additional priming valve    | This operates an additional dedicated priming point. |
| 8 Additional panel switch     | This operates an additional priming valve.           |

## Auto-Prime Switch

This allows you to manually or automatically prime the pump.

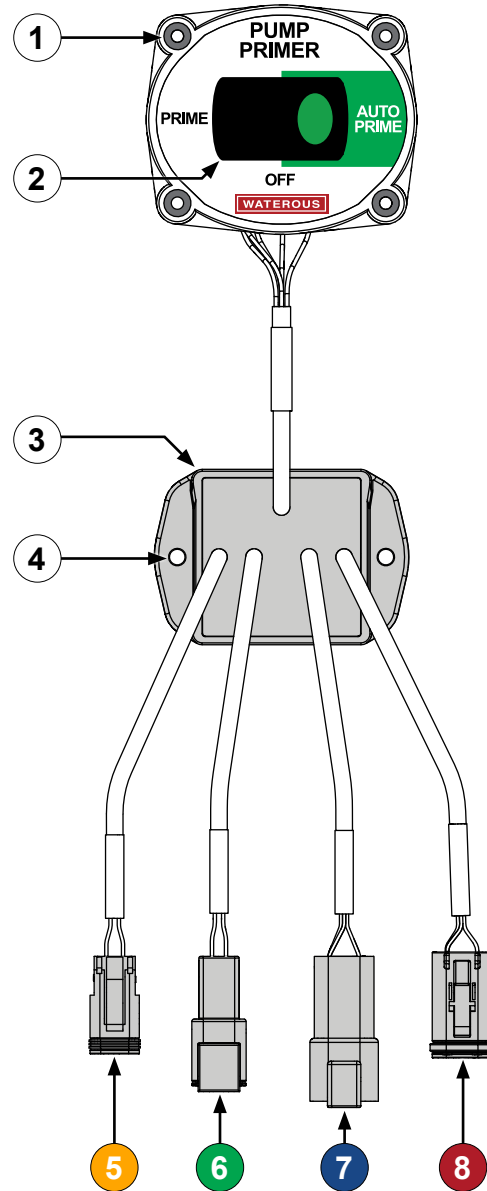

## Auto-Prime Switch

This allows you to manually or automatically prime the pump.

| Feature                            | Description   |
|------------------------------------|---|
| 1 Mounting holes—Panel             | This mounts the switch to the apparatus.                              |
| 2 Button                           | This operates the priming function.                                   |
| 3 Enclosure                        | This contains the electronic components.                              |
| 4 Mounting holes—Enclosure         | This mounts the enclosure to the apparatus.                           |
| 5 Pressure switch connector        | This connects to the pressure switch—DT06-2S.                         |
| 6 Priming valve solenoid connector | This connects to the priming valve solenoid when applicable—DTM04-2P. |
| 7 Air primer connector             | This connects to the air primer solenoid—DT04-4P.                     |
| 8 Power connector                  | This connects to apparatus power or to the previous switch—DT06-4S.   |

## Standard Push Button Switch

This allows you to manually prime the pump.

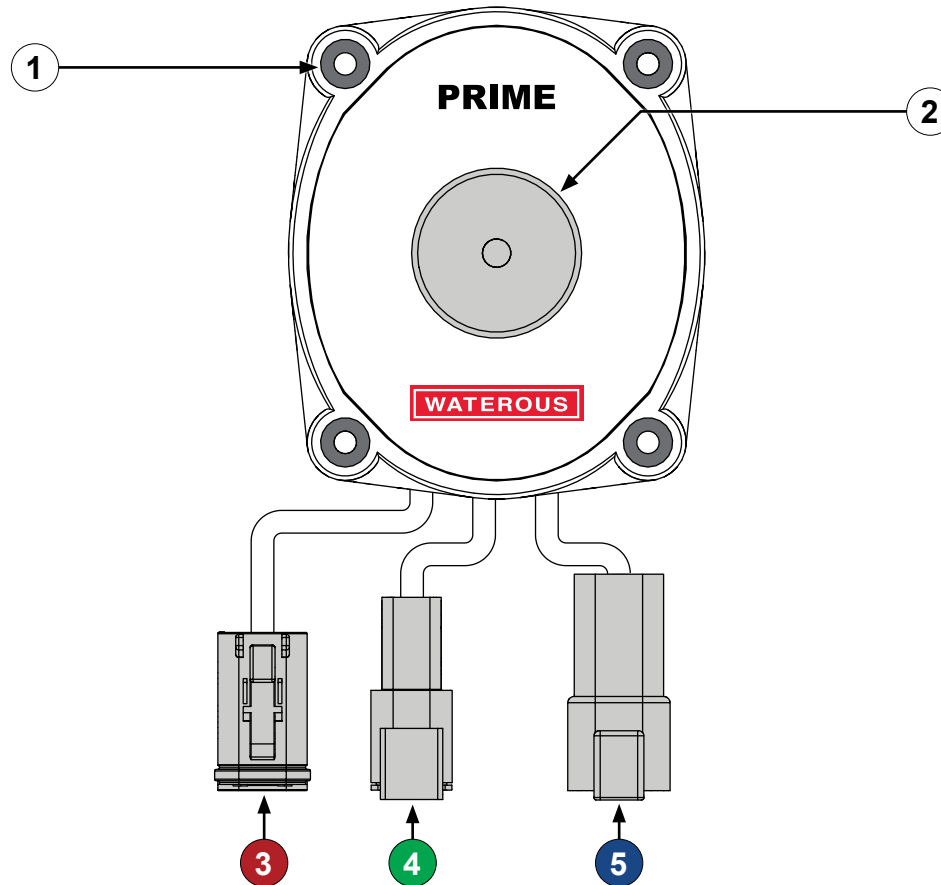

| Feature                            | Description   |
|------------------------------------|---|
| 1 Mounting holes                   | This mounts the switch to the apparatus.  |
| 2 Button                           | This activates the priming operation.   |
| 3 Power connector                  | This connects to apparatus power or to the previous switch—DT06-4S, Pin 1=12 V, Pin 2=Ground. |
| 4 Priming valve solenoid connector | This connects to the priming valve solenoid when applicable—DTM04-2P.                         |
| 5 Air primer connector             | This connects to the air primer solenoid—DT04-4P.   |

## Oversized Push Button Switch

This allows you to manually prime the pump with a larger style button.

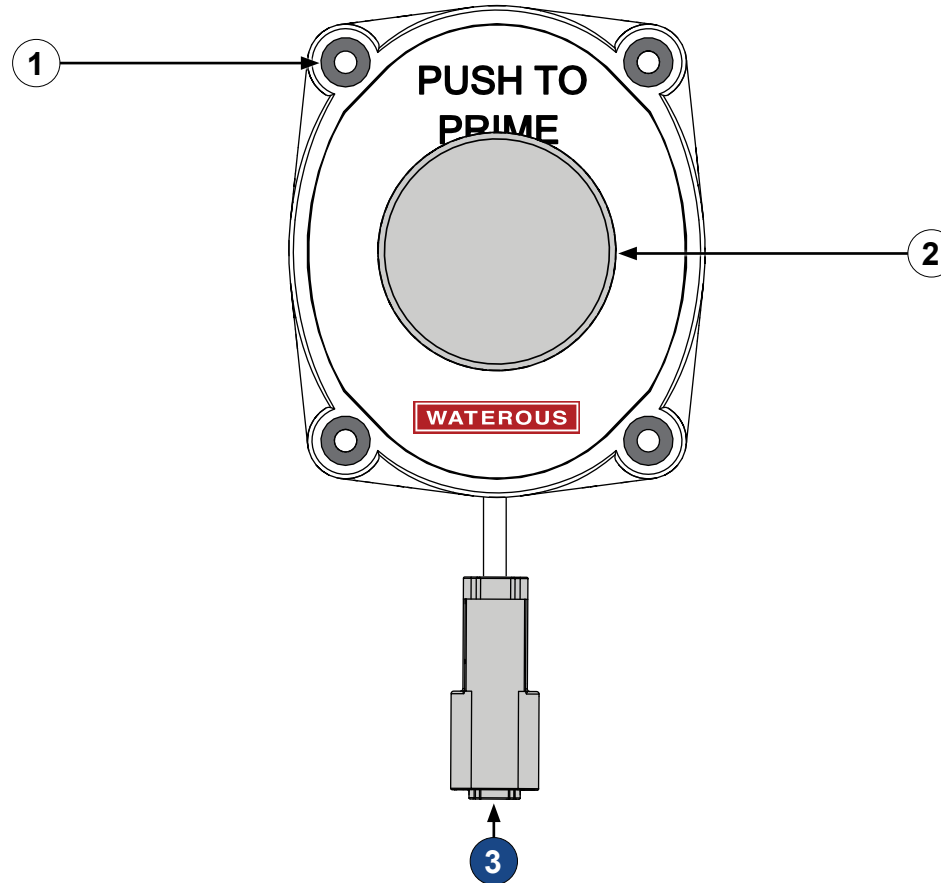

| Feature                | Description  |
|------------------------|--|
| 1 Mounting holes       | This mounts the switch to the apparatus.                                     |
| 2 Button               | This activates the priming operation.  |
| 3 Air primer connector | This connects to the air primer solenoid—DT04-4P using a Y-splitter—DT06-4S. |

## Venturis Air Primer

This generates the vacuum required to prime the fire pump.

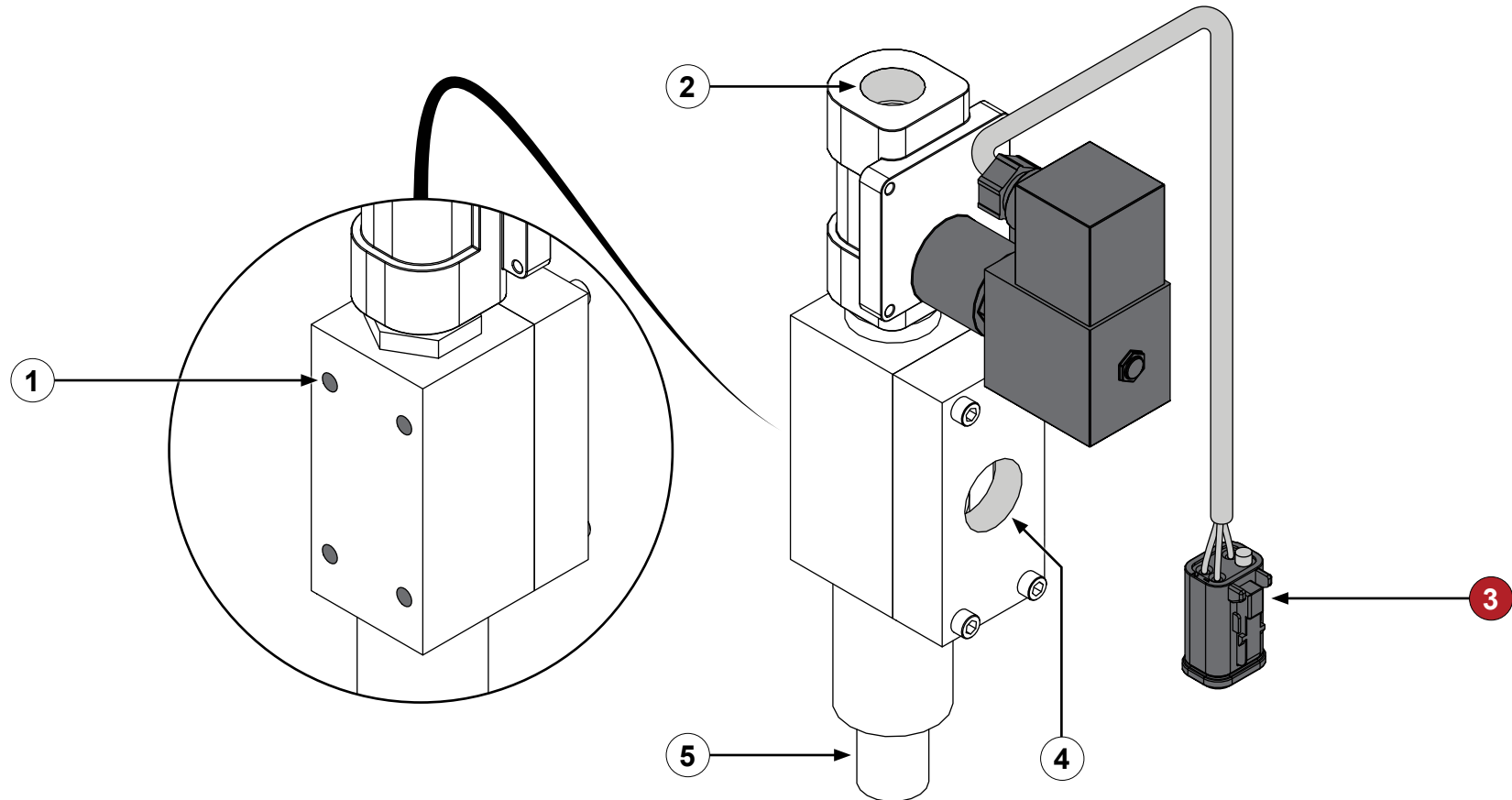

| Feature                | Description   |
|------------------------|---|
| 1 Mounting holes       | This mounts the air primer to the apparatus.                                    |
| 2 Compressed air inlet | This connects to the apparatus air supply—3/8 NPT.                              |
| 3 Switch connector     | This connects to the switch—DT06-4S, cable length: 118 inches (3.0 m).          |
| 4 Priming valve inlet  | This connects to the priming valves in your application—up to 6 priming valves. |
| 5 Exhaust port         | This is where the evacuated air exits the air primer—3/4-inch outer diameter.   |

## Priming Valve

This allows air to evacuate the fire pump.

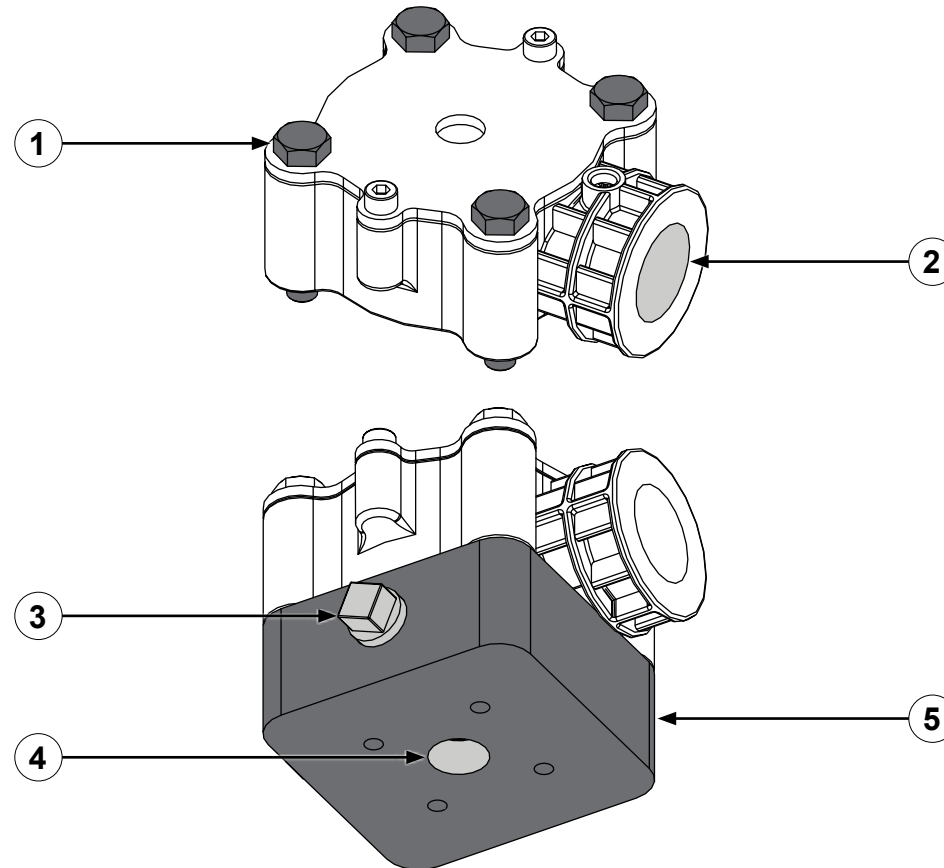

| Feature                | Description  |
|------------------------|--|
| 1 Mounting hardware    | This mounts the priming valve to the fire-pump intake or priming valve base. |
| 2 Vacuum outlet        | This connects to the air primer.   |
| 3 Vacuum inlet—plugged | This plugs the unused inlets.  |
| 4 Vacuum inlet         | This draws the vacuum from the pump.   |
| 5 Priming valve base   | This is an alternative mount for some applications.                          |

## Pressure Protection Valve

This reserves a supply of compressed air in the system to prevent total depletion of the air supplied to systems that share the air supply on the apparatus. This is an available option from Waterous, or is locally sourced by the installer. It is the responsibility of the installer to make sure that a pressure-protection device is incorporated into the pneumatics of the apparatus when a compressed air source is shared between the priming system and other vital systems such as the air-brake system on the apparatus.

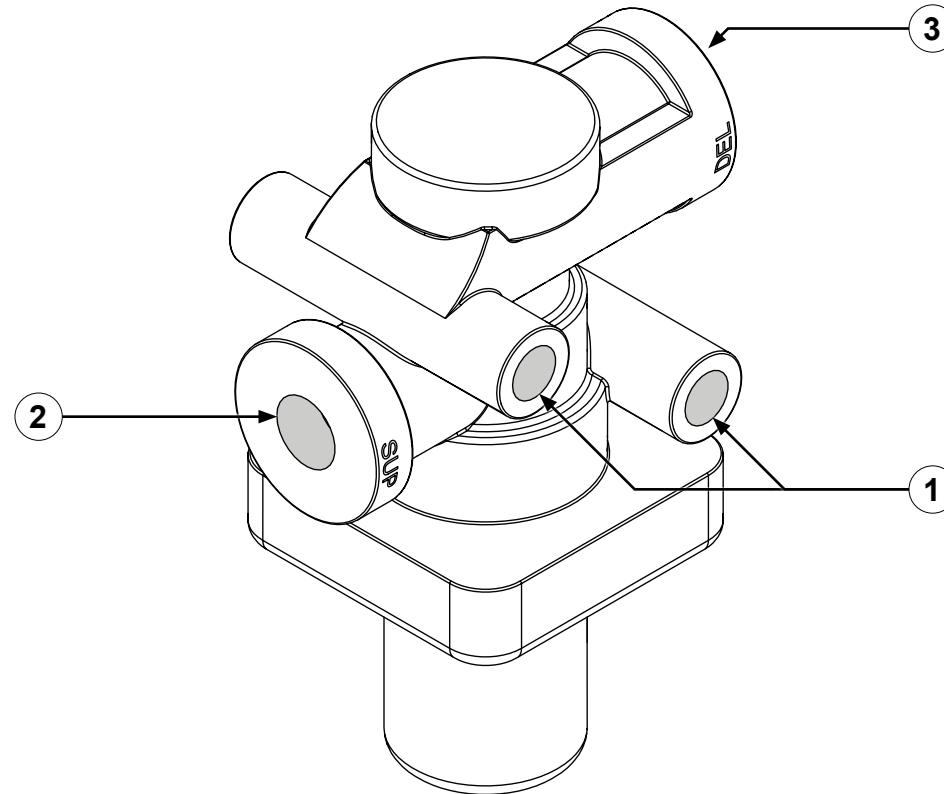

| Feature                | Description  |
|------------------------|--|
| 1 Mounting holes       | This mounts the valve to the apparatus.                                      |
| 2 Supply port—input    | This connects to the compressed-air supply—1/4 NPT, 70 PSI closing pressure. |
| 3 Delivery port—output | This connects to the air primer—1/4 NPT.                                     |



## Pressure Switch

This facilitates the auto-prime operation.

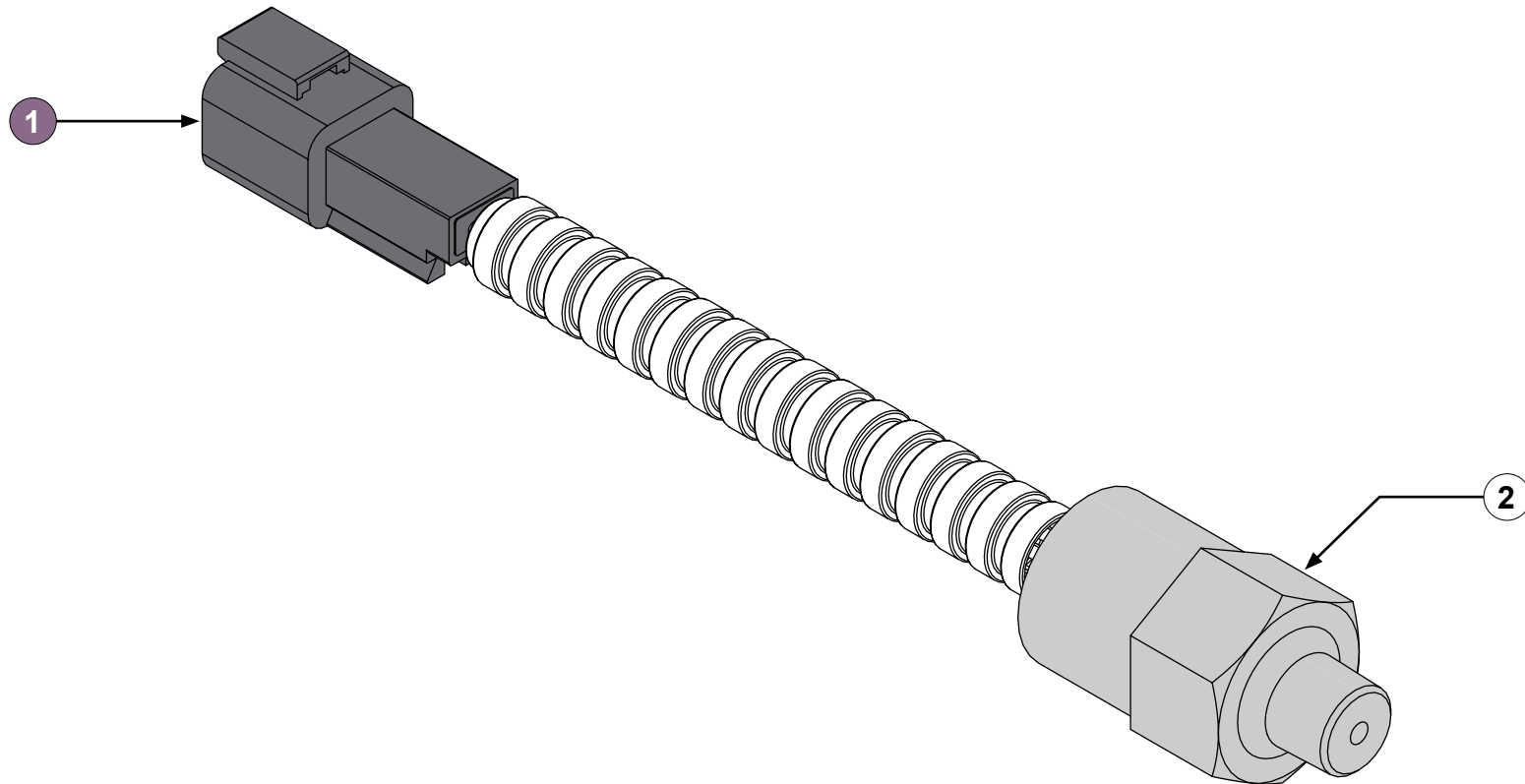

| Feature          | Description   |
|------------------|---|
| 1 Connector      | This connects to the auto-prime switch—DT04-2P, cable length: 10 inches (254 mm). |
| 2 Switch housing | This threads into the fire-pump discharge—1/4 NPT.                                |

## Priming Valve Solenoid

This allows you to manually prime individual sections of the apparatus plumbing. This is an optional component used with multi-location priming applications.

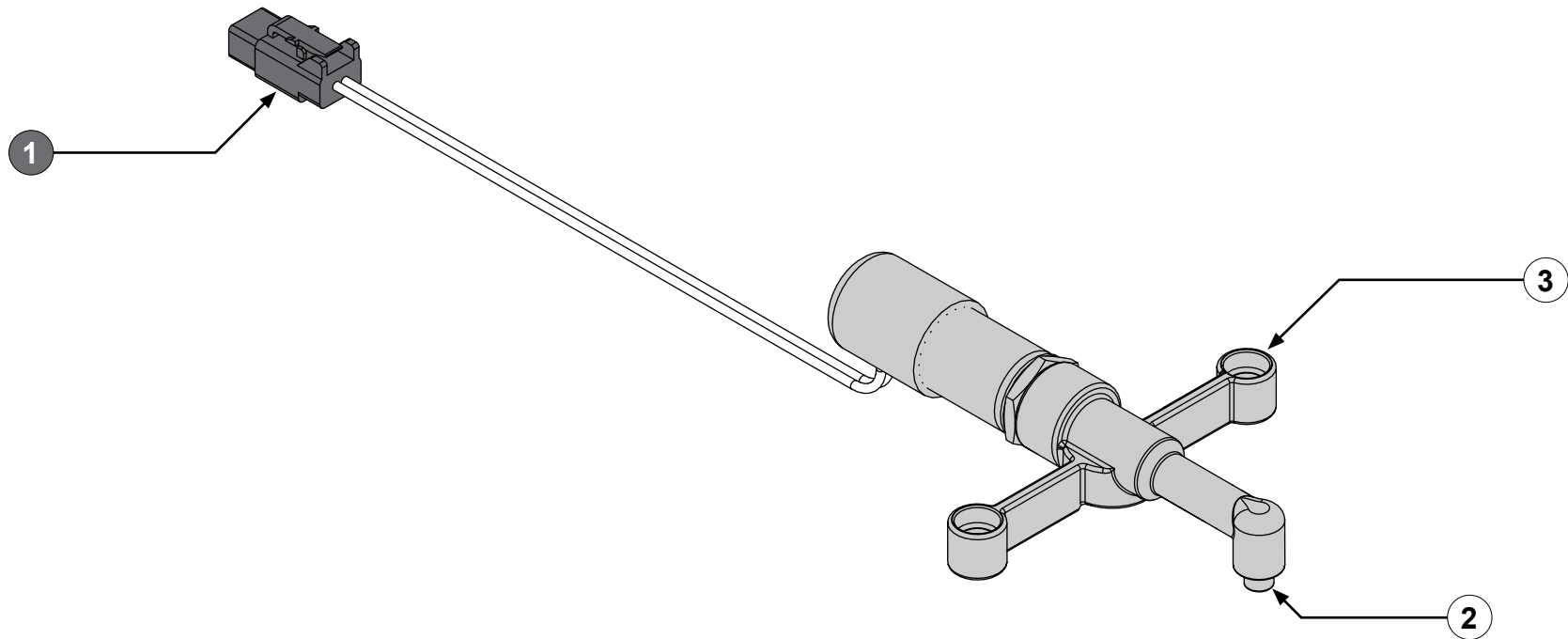

| Feature          | Description  |
|------------------|--|
| 1 Connector      | This connects to the switch—DTM06-2S, cable length: 6.5 inches (165 mm). |
| 2 Vent port      | This controls the air to move through the priming valve.                 |
| 3 Mounting holes | This mounts the solenoid to the priming valve.                           |

## Priming Valve Solenoid Extension Cable

This cable extends the distance between the switch and the priming-valve solenoid install location. **Note:** *The inclusion of this cable is dependent on your configuration. It is also available separately if required by your application.*

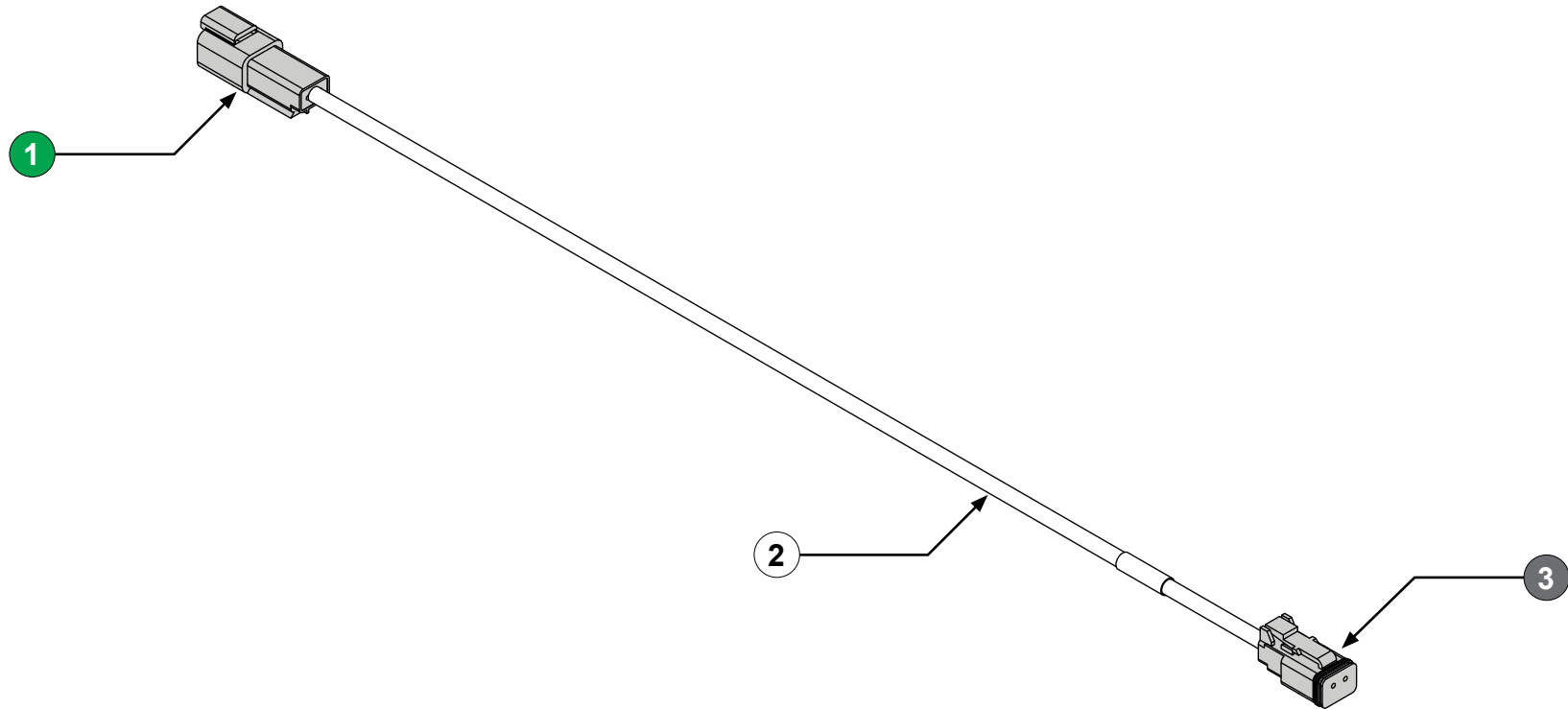

| Feature     | Description   |
|-------------|---|
| 1 Connector | This connects to the switch—DTM04-2P.                 |
| 2 Cable     | This cable length is 70 inches (1,778 mm).            |
| 3 Connector | This connects to the priming-valve solenoid—DTM06-2S. |

## Pressure Switch Extension Cable

This cable extends the distance between the switch and the pressure switch install location. **Note:** *The inclusion of this cable is dependent on your configuration. It is also available separately if required by your application.*

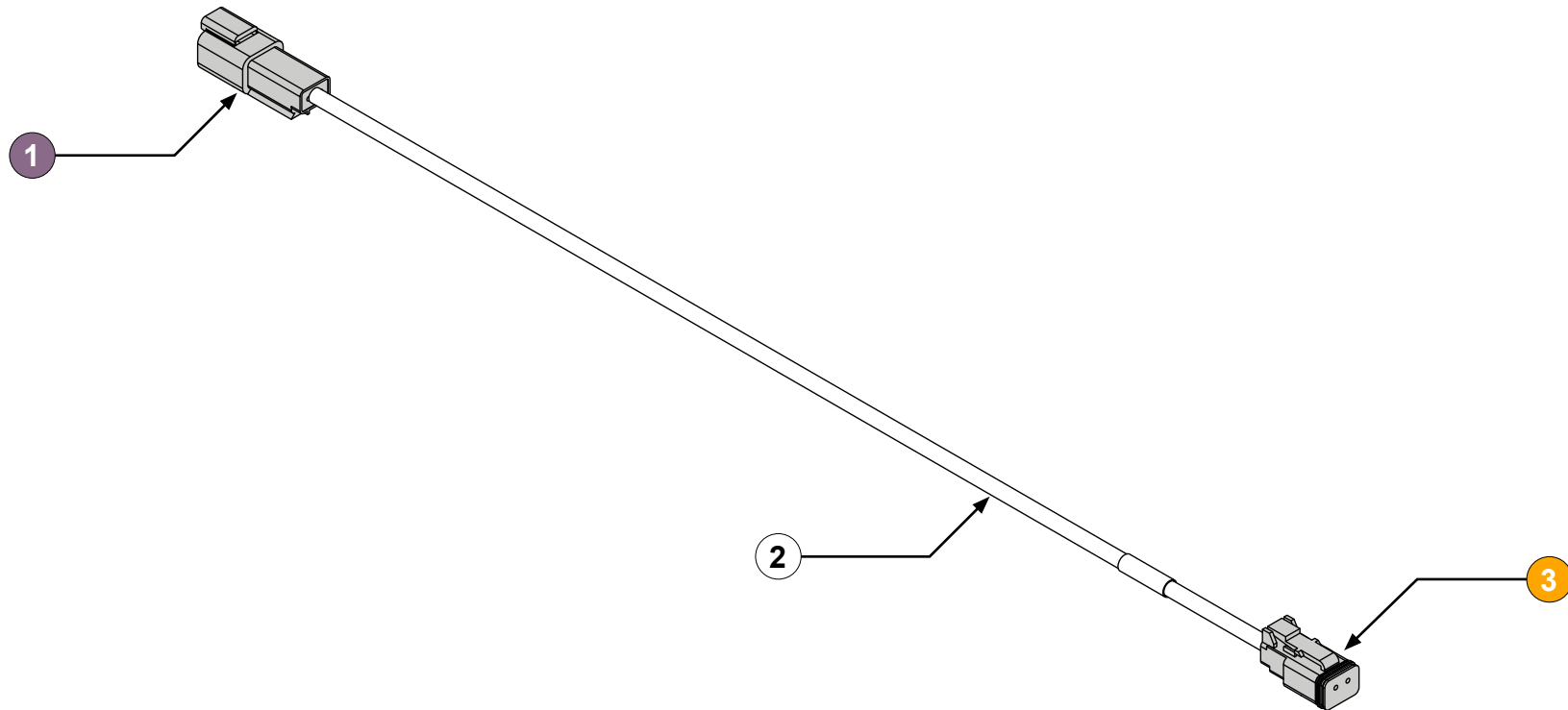

| Feature     | Description                                     |
|-------------|---|
| 1 Connector | This connects to the auto-prime switch—DT04-2P. |
| 2 Cable     | This cable length is 70 inches (1,778 mm).      |
| 3 Connector | This connects to the pressure switch—DT06-2S.   |

## Air Primer Extension Cable—Optional

This optional cable extends the distance between the switch and the air primer install location.

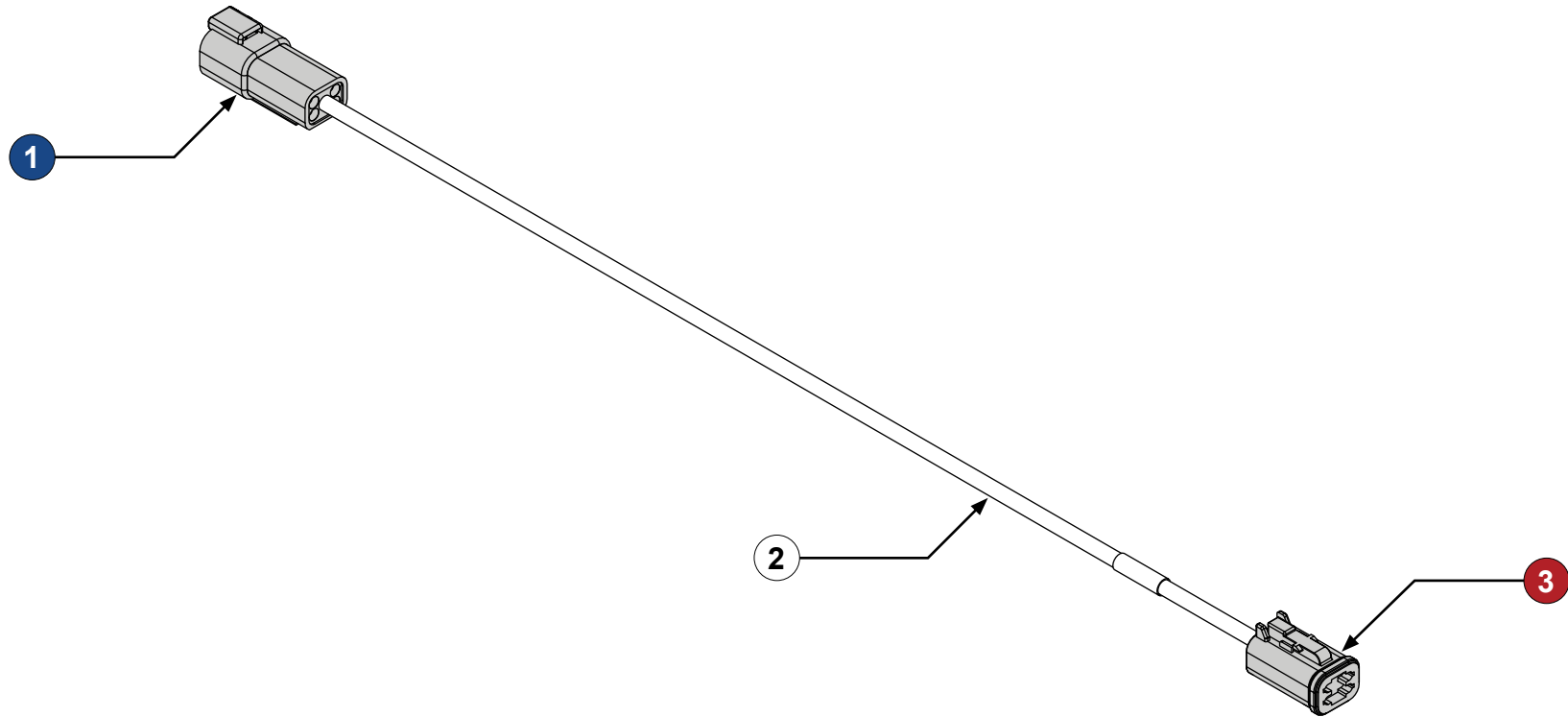

| Feature     | Description  |
|-------------|--|
| 1 Connector | This connects to the air primer solenoid or a solenoid-equipped priming valve—DT04-4P. |
| 2 Cable     | This cable length is 70 inches (1,778 mm).   |
| 3 Connector | This connects to the switch—DT06-4S.   |

## Oversized Push Button Y-Splitter

This splitter allows the use of the oversized push button switch.

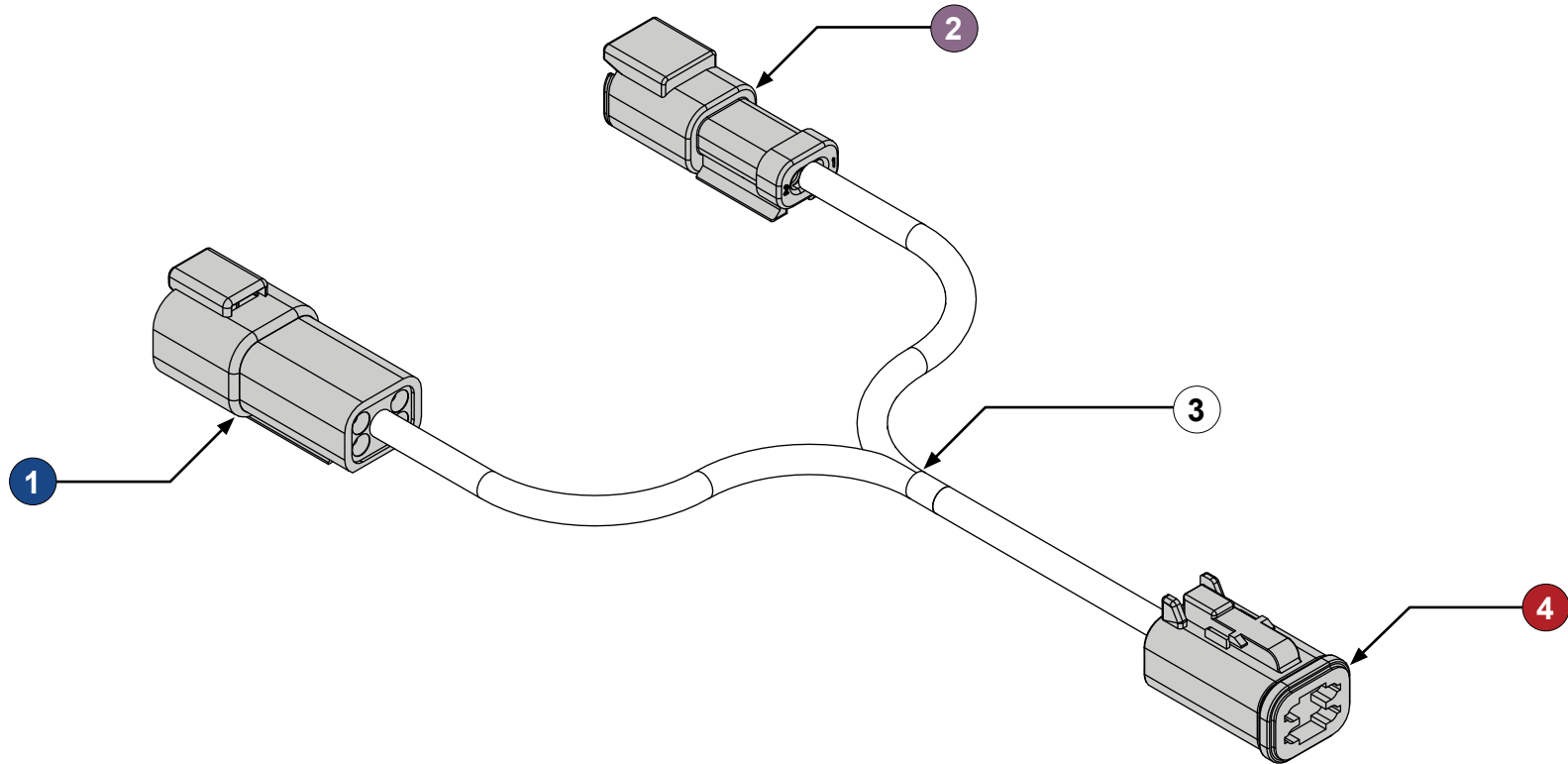

| Feature     | Description  |
|-------------|--|
| 1 Connector | This connects to the Venturis Air Primer—DT04-4P.          |
| 2 Connector | This connects to the apparatus power—DT04-2P.              |
| 3 Cable     | This cable length is 6 inches (152 mm).                    |
| 4 Connector | This connects to the oversized push button switch—DT06-4S. |



## Installation Overview

This equipment is intended to be installed by a person or persons with the basic knowledge of installing similar equipment. Contact Waterous with questions about installing the equipment. The installation may require the following tasks and abilities:

- Locating, drilling, and cutting features into the apparatus.
- Connecting electronic devices.
- Configuring and calibrating the system.
- Final testing.
- Do not install the equipment if you are not familiar with the tools and skills needed to safely perform required procedures—proper installation is the responsibility of the purchaser.

## Determining Cable and Wire Routing

Use the *Wiring Best Practices* document, available at [www.waterousco.com](http://www.waterousco.com), as a guide to select and route wiring for your application.

## Preparing for the Installation

Read and understand all the installation instructions before installing the equipment. Prepare a suitable, well-lit area, and gather all the necessary tools before you begin the installation.

# NOTICE

## Before Operation

- Read and understand all the instructions provided.
- Check all fluid levels and replenish if necessary.
- Remove all shipping plugs and install the operation plugs or caps.



## Optional Equipment

Be aware that the installation instruction may include optional equipment not included in your application.

## Tubing Requirements

Use the following specifications to locally source tubing for your application.

### Vacuum Tubing

This is only required if the air primer and priming valve are not installed at the factory.

- Outer diameter: 3/4-inch
- Inner diameter: 1/2-inch to 5/8-inch
- Color: Black, ultraviolet resistant
- Durometer: 61A minimum, must be compression fitting compatible
- Must have 2 fiber braids with oil resistant jacket
- Must withstand 25-inch Hg of vacuum
- Must be capable of servicing water
- Connection: 3/4-inch compression fitting

### Compressed Air Tubing

- Outer diameter: 1/2-inch
- Inner diameter: 3/8-inch

## Compressor Requirement

Your compressor must be rated for a minimum of 18 cfm at 1250 rpm to properly operate the air primer.

## Symbols

Symbols are used to illustrate additional tools or operations that are required to complete the instructions.



Drill—This symbol tells you to drill holes in the apparatus.



Jig saw—This symbol tells you to make a cutout in the apparatus.



## Determining the Installation Requirements

The Venturis priming system is available in various configurations. Ranging from factory installed on the pump and transmission, to individual, uninstalled components. The following instructions describe how to install and connect each of the components in the Venturis priming system. Use the instruction appropriate to your application to install your system.

The most basic system requires cutting and drilling the operator panel to install the switch, connecting the appropriate cables to various components, integrating into apparatus power, and connecting the hose or tubing components to the compressed-air supply on the apparatus.

## Installation Requirements

Use the following information to install the defined components.

Only install the air primer below the priming valve.

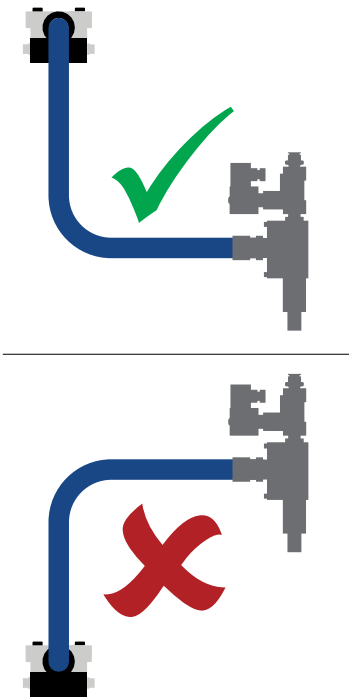

Only install the air primer with the exhaust directed downward.

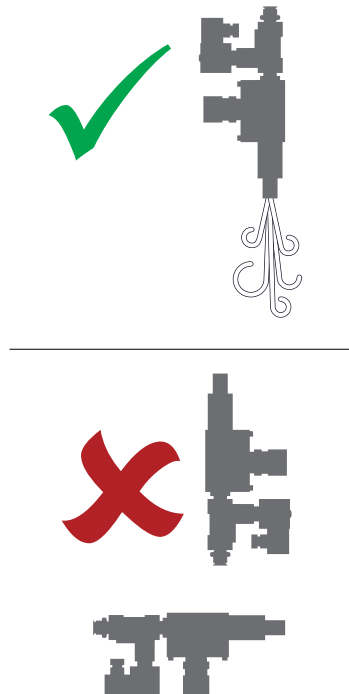

Do not install the air primer where the exhaust flow is impeded or where the exhaust flow will damage other components on the apparatus.

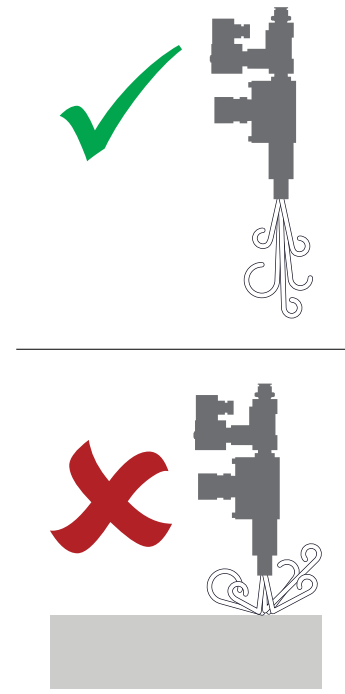

Make sure that you install a pressure protection valve when the compressed-air source is shared between systems on the apparatus.

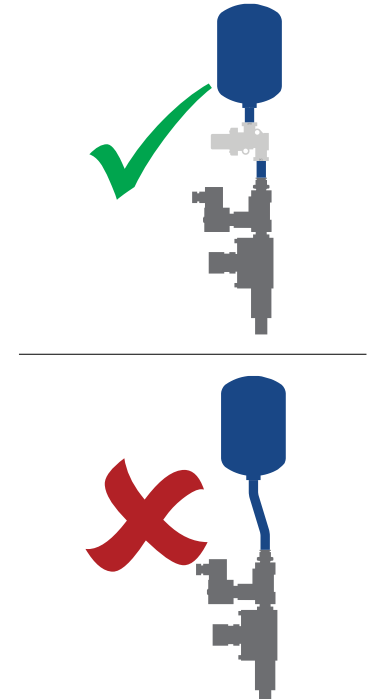

## Auto-Prime Switch Cutout Dimensions

Use the illustration to create the cutout and drill the mounting holes for the auto-prime switch.

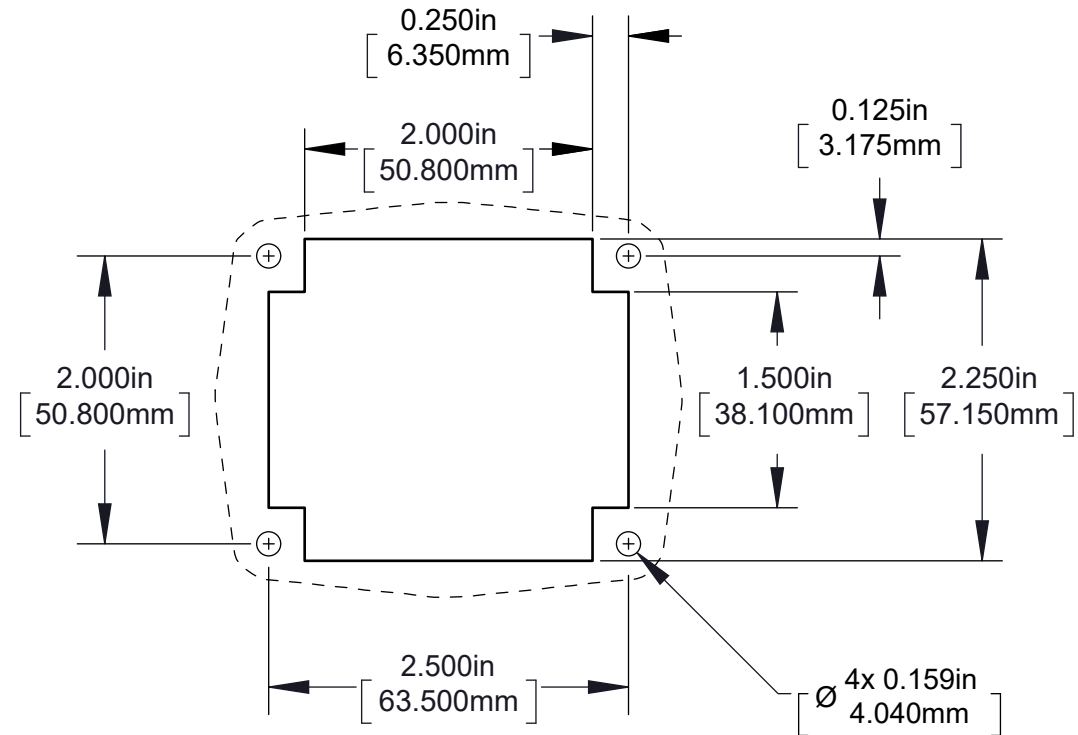

## Standard Push Button Switch Cutout Dimensions

Use the illustration to create the cutout and drill the mounting holes for the standard push button switch.

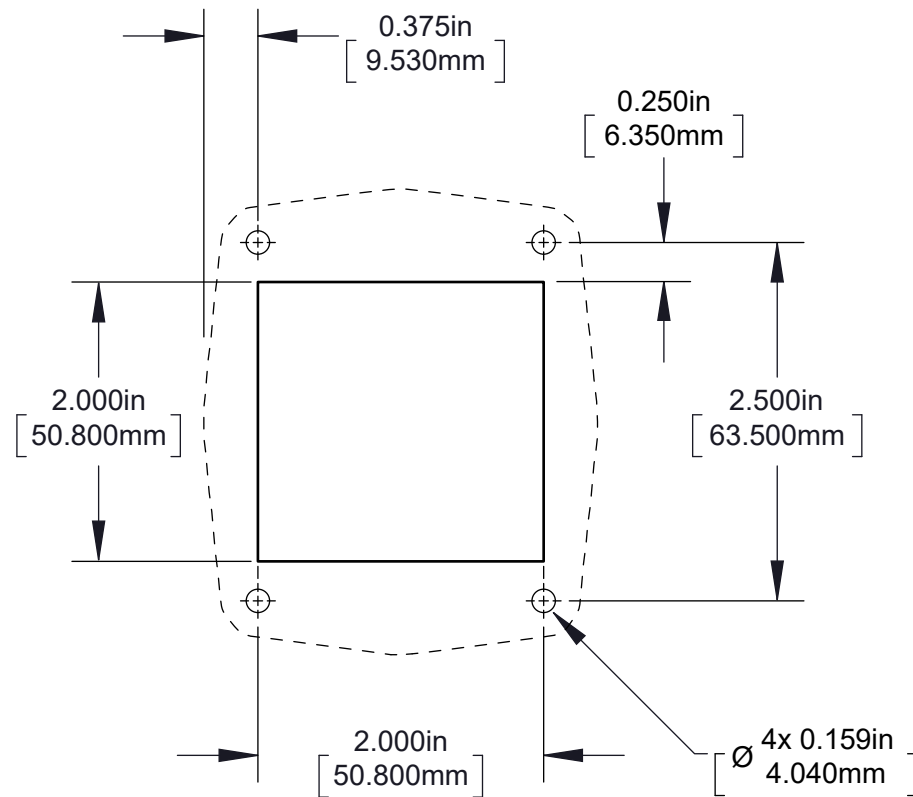

## Oversized Push Button Switch Cutout Dimensions

Use the illustration to create the cutout and drill the mounting holes for the oversized push button switch.

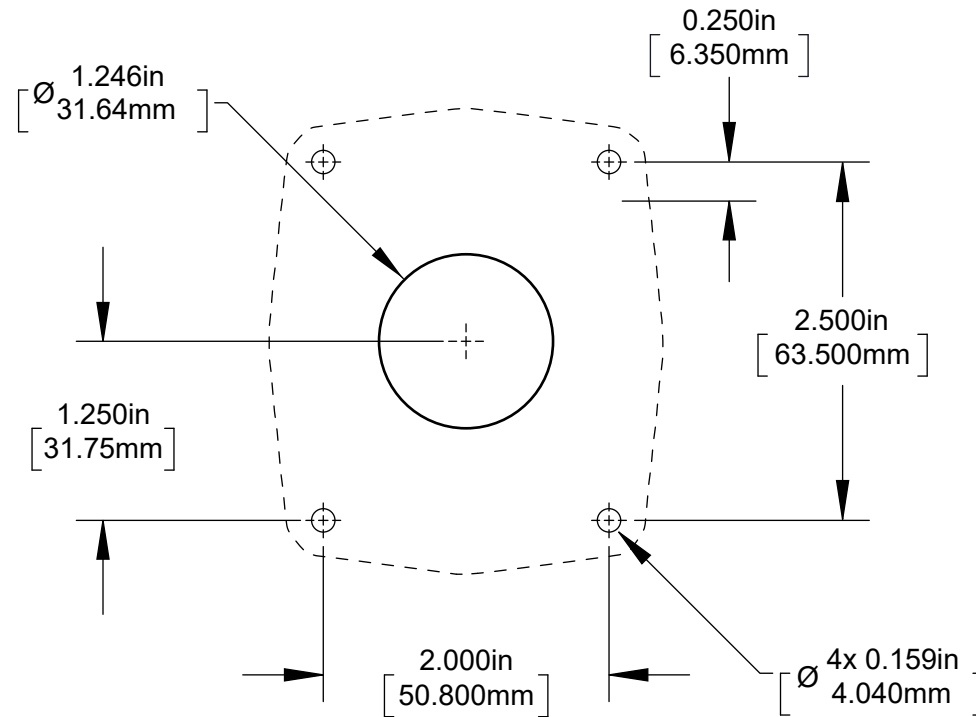

## Air Primer Mounting Dimensions

The air primer is typically mounted on the transmission at the factory, however it can also be mounted remotely. Use the illustration to drill the mounting holes for the air primer if you are mounting the air primer remotely.

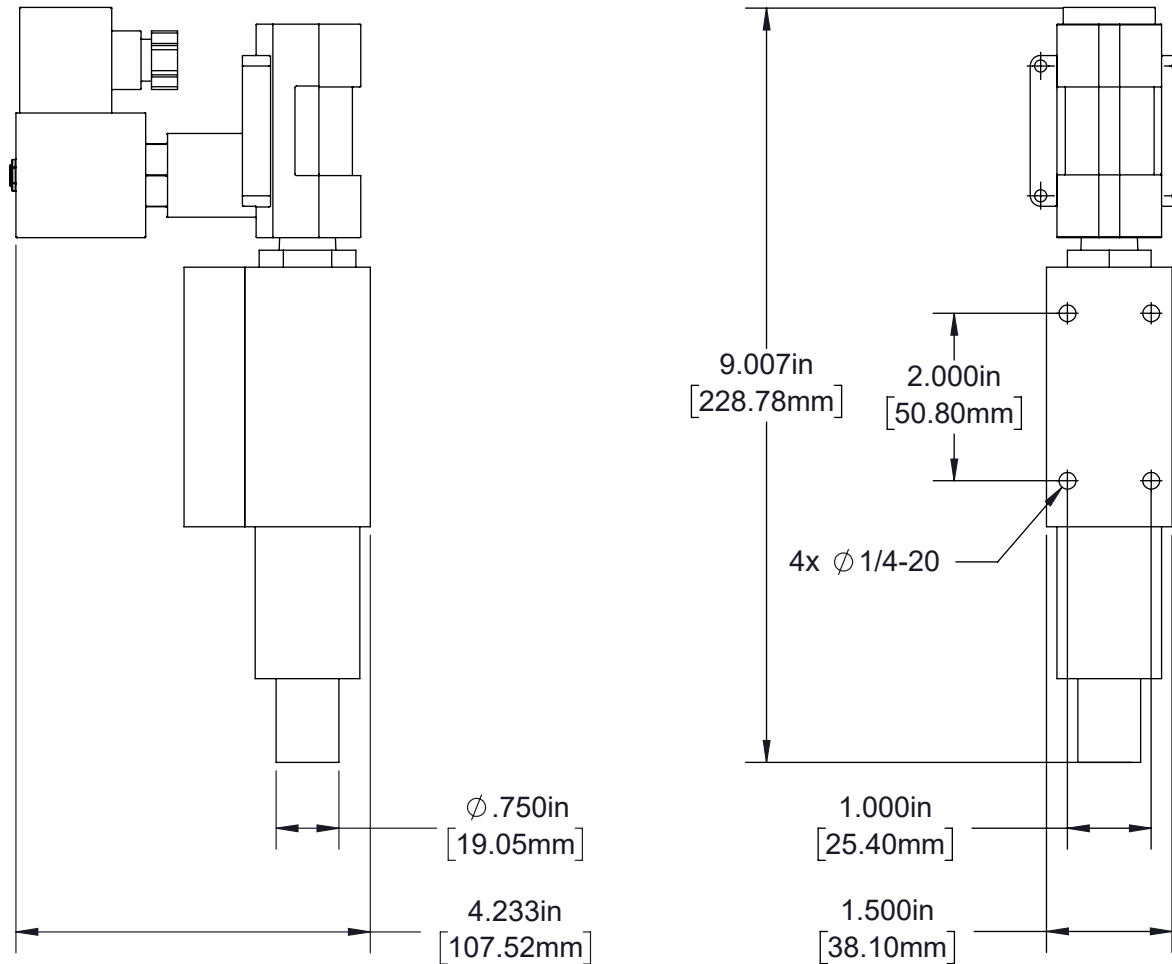

## Pressure Protection Valve Mounting Dimensions

Use the illustration to drill the mounting holes for the pressure protection valve.

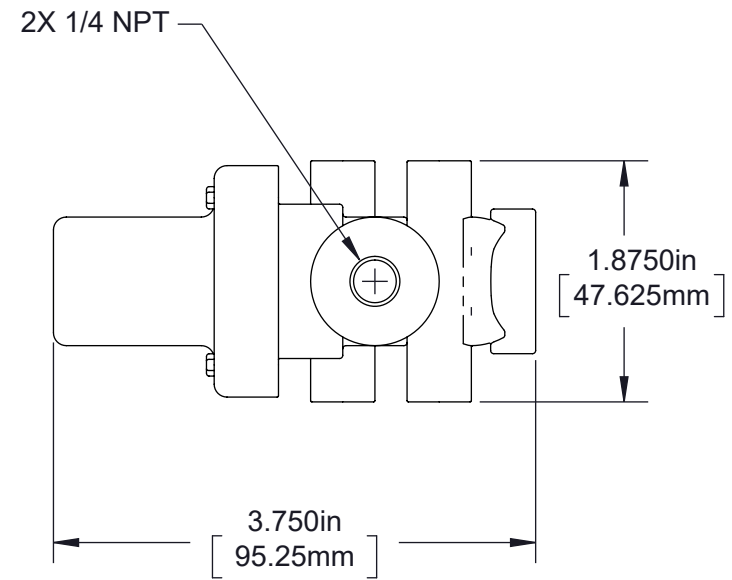
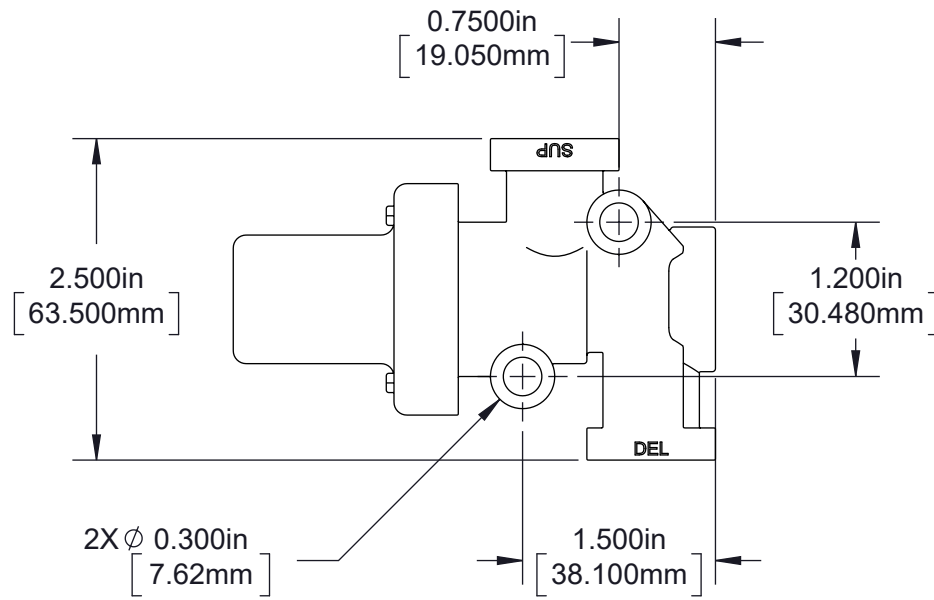

## Installing the Auto-Prime Switch

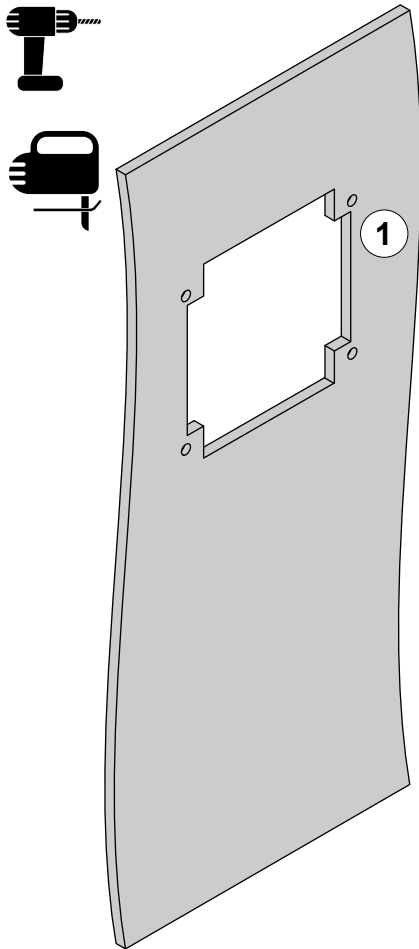

### Panel Cutout and Mounting Holes

Use the illustration and instruction to create the cutout and mounting holes for the auto-prime switch.

- 1 Create the cutout and drill the mounting holes for the switch. Refer to: **"Auto-Prime Switch Cutout Dimensions"** on page 34.

## Installing the Auto-Prime Switch

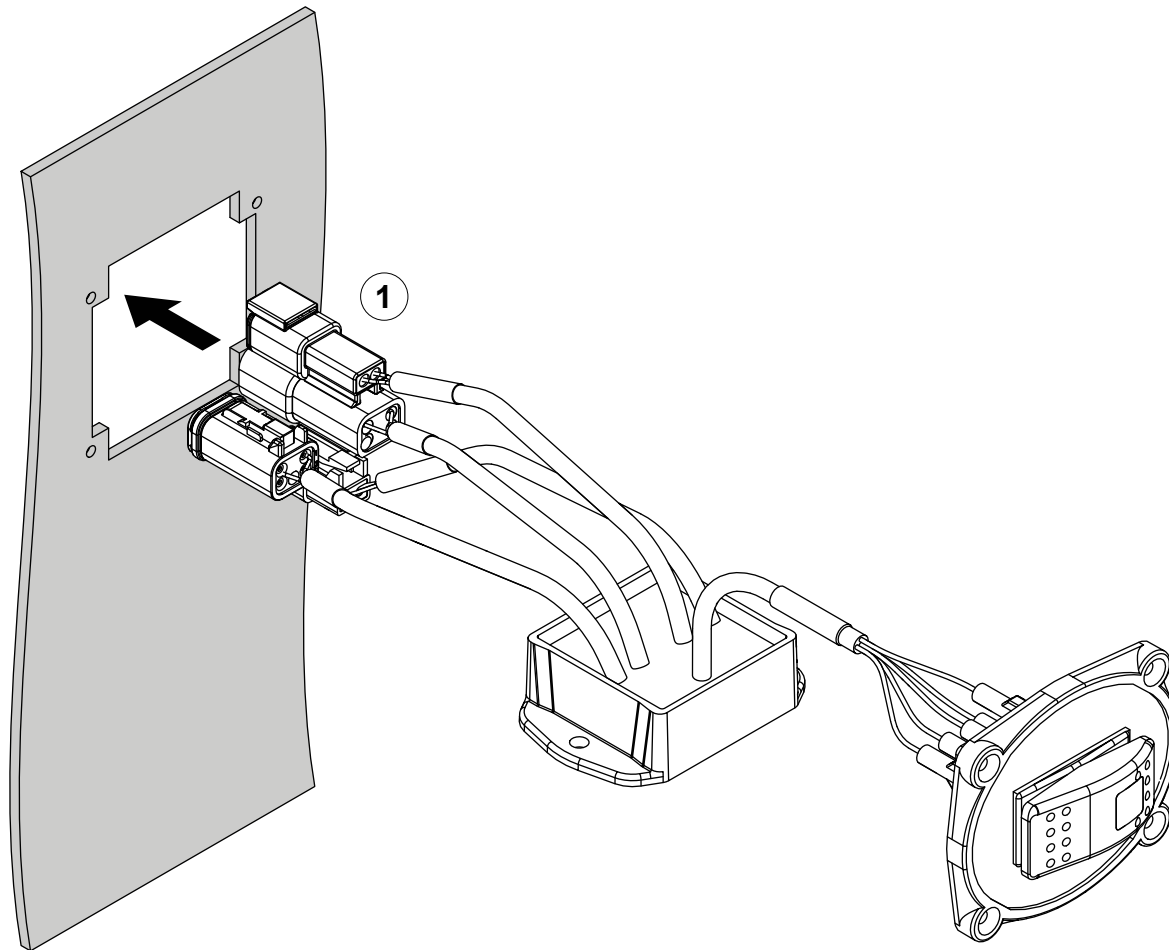

### Positioning the Switch

Use the illustration and instruction to mount the auto-prime switch on the panel.

- 1 Route the plugs and enclosure through the cutout to position it for installation.



## Installing the Auto-Prime Switch

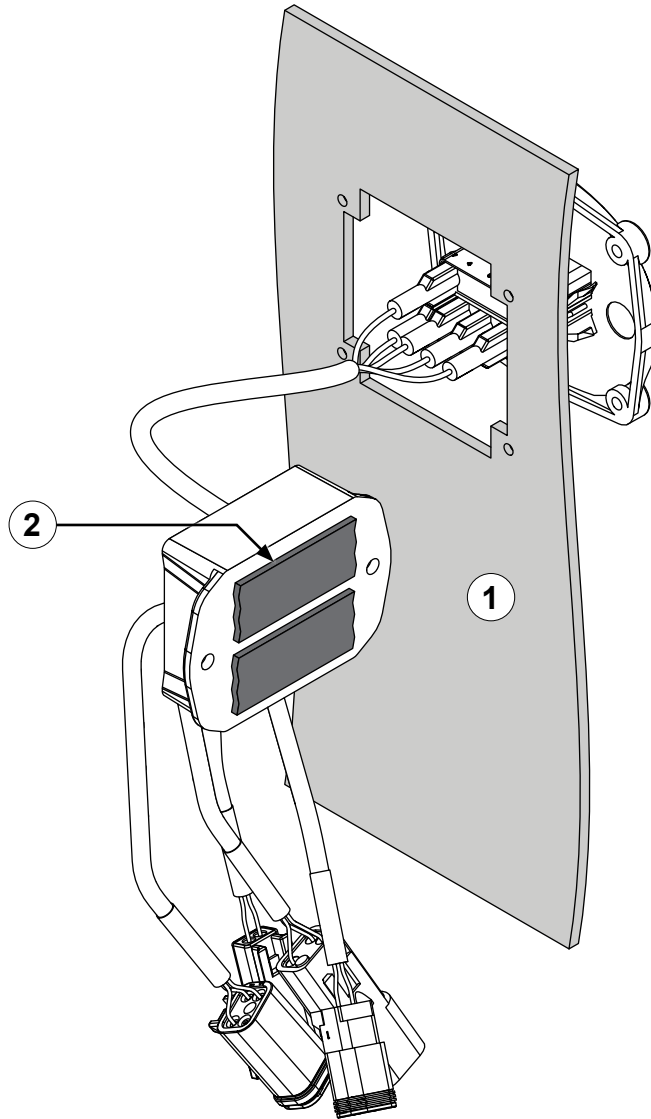

### Mounting the Enclosure

Use the illustration and instructions to mount the auto-prime switch on the panel.

- 1 Use a clean rag and alcohol to clean the area where you intend to mount the enclosure.
- 2 Use the included high-bond tape to affix the enclosure to the panel.

## Installing the Auto-Prime Switch

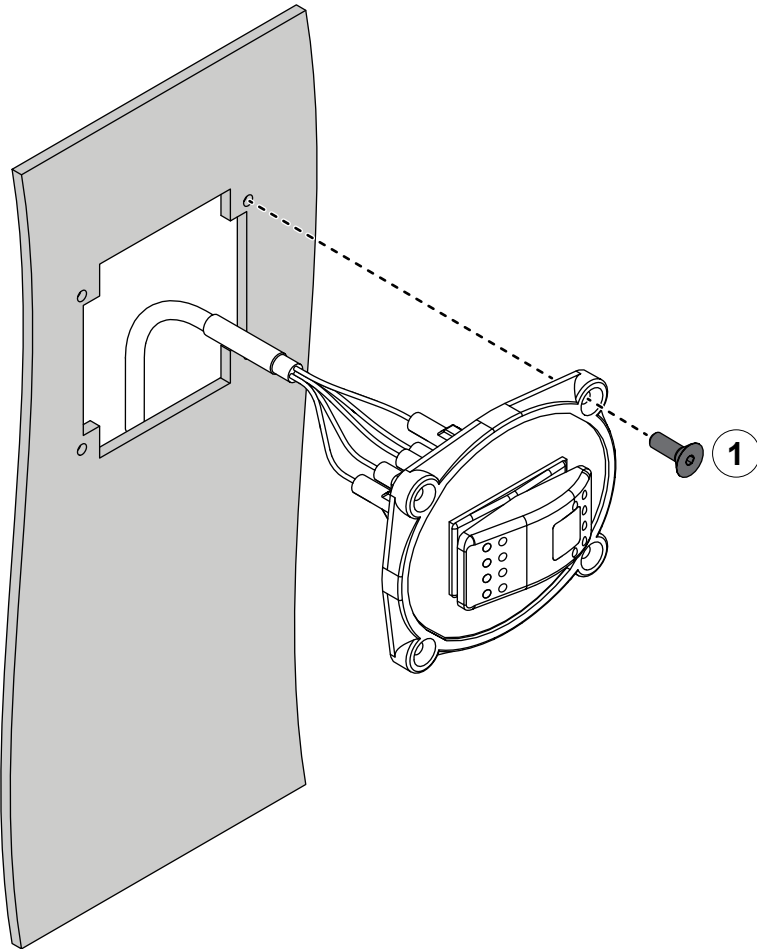

### Mounting the Panel

Use the illustration and instruction to mount the auto-prime switch on the panel.

- 1 Use locally sourced mounting hardware to install the switch.

## Installing the Standard Push Button Switch

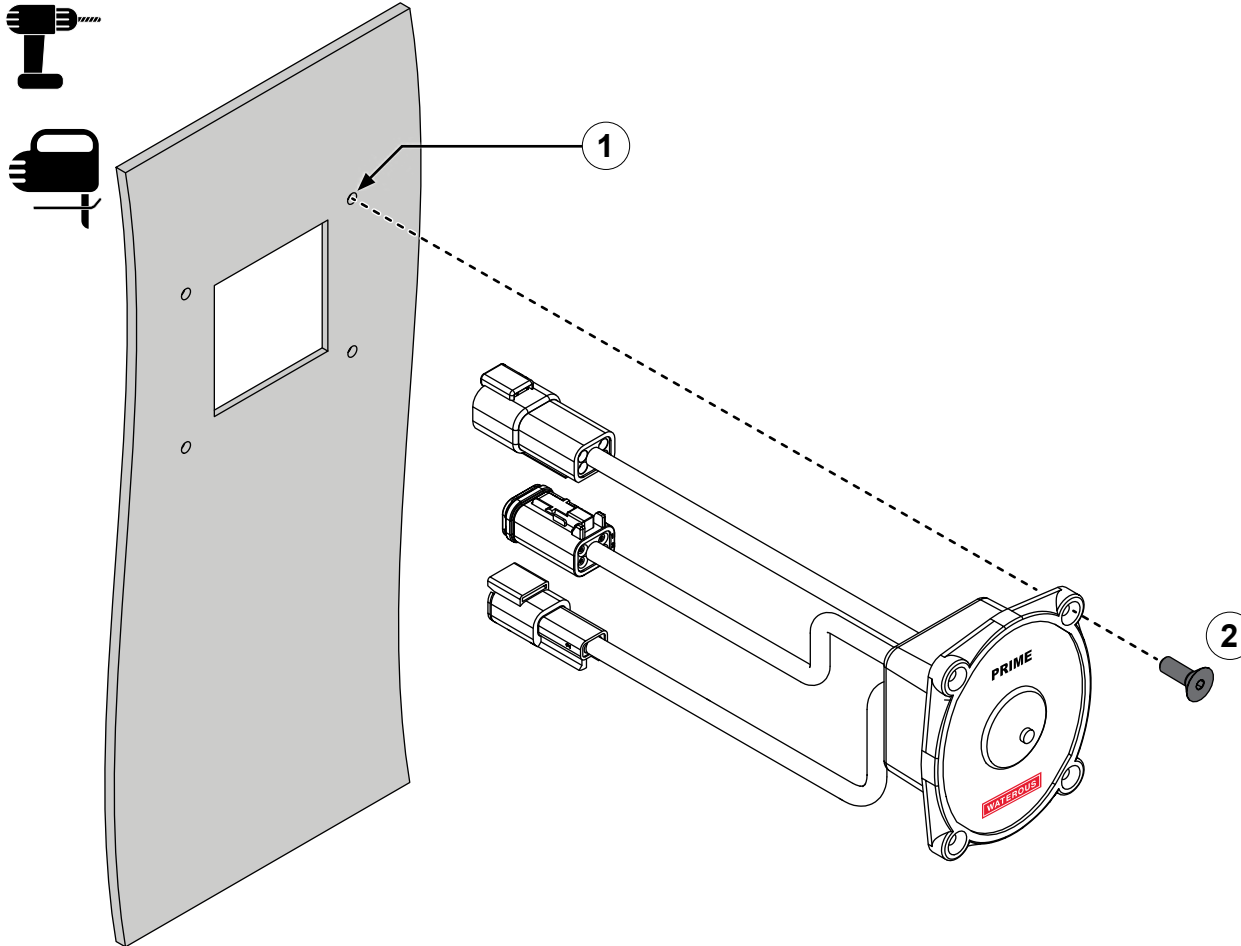

Use the illustration and instructions to mount the standard push button switch on the panel.

- 1 Create the cutout and drill the mounting holes for the switch. Refer to: **"Standard Push Button Switch Cutout Dimensions"** on page 35.
- 2 Insert the switch wiring through the cutout, then use locally sourced mounting hardware to install the switch.

## Installing the Oversized Push Button Switch

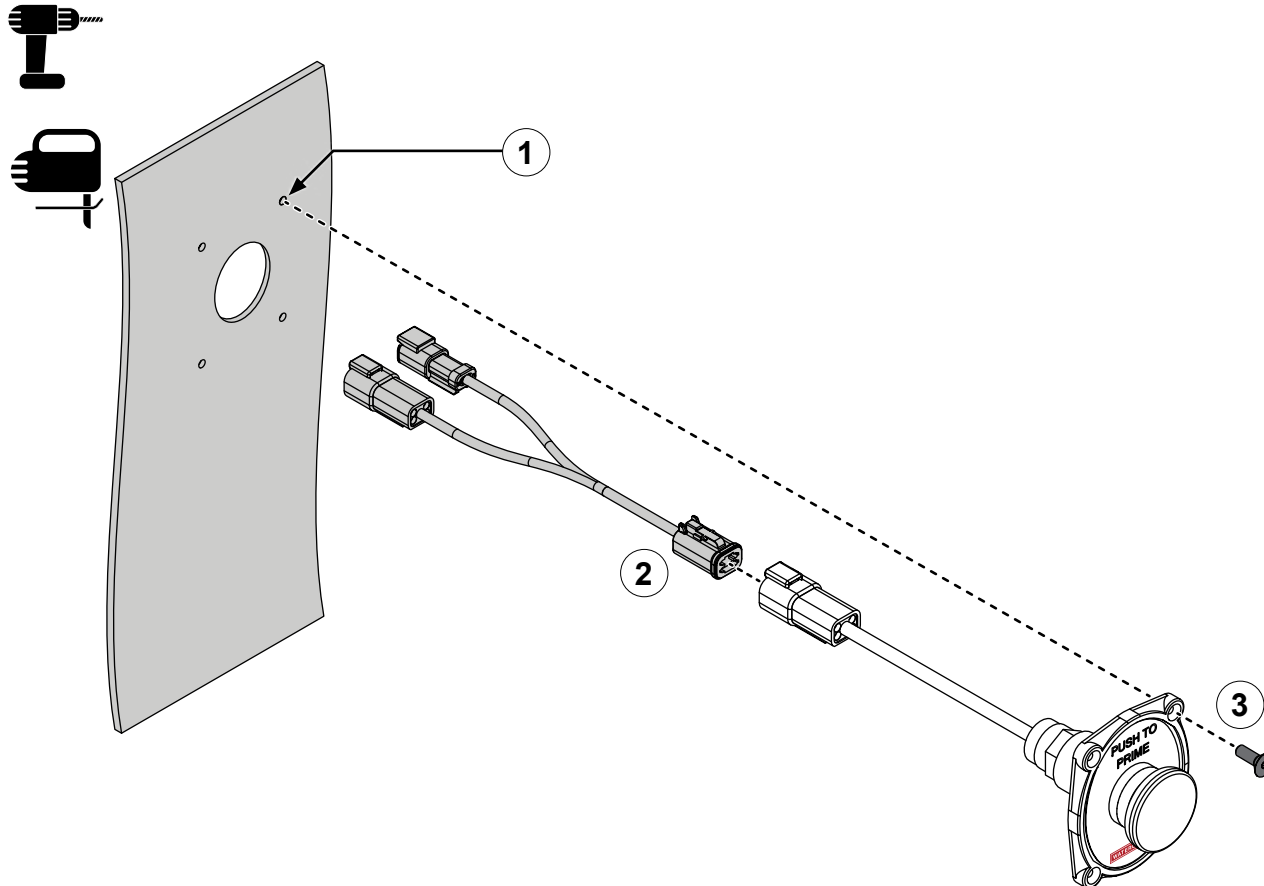

Use the illustration and instructions to mount the oversized push button switch on the panel.

- 1 Create the cutout and drill the mounting holes for the switch. Refer to: **"Oversized Push Button Switch Cutout Dimensions"** on page 36.
- 2 Connect the oversized push button Y-splitter to the oversized push button switch.
- 3 Insert the switch wiring through the cutout, then use locally sourced mounting hardware to install the switch.

## Installing the Priming Valve

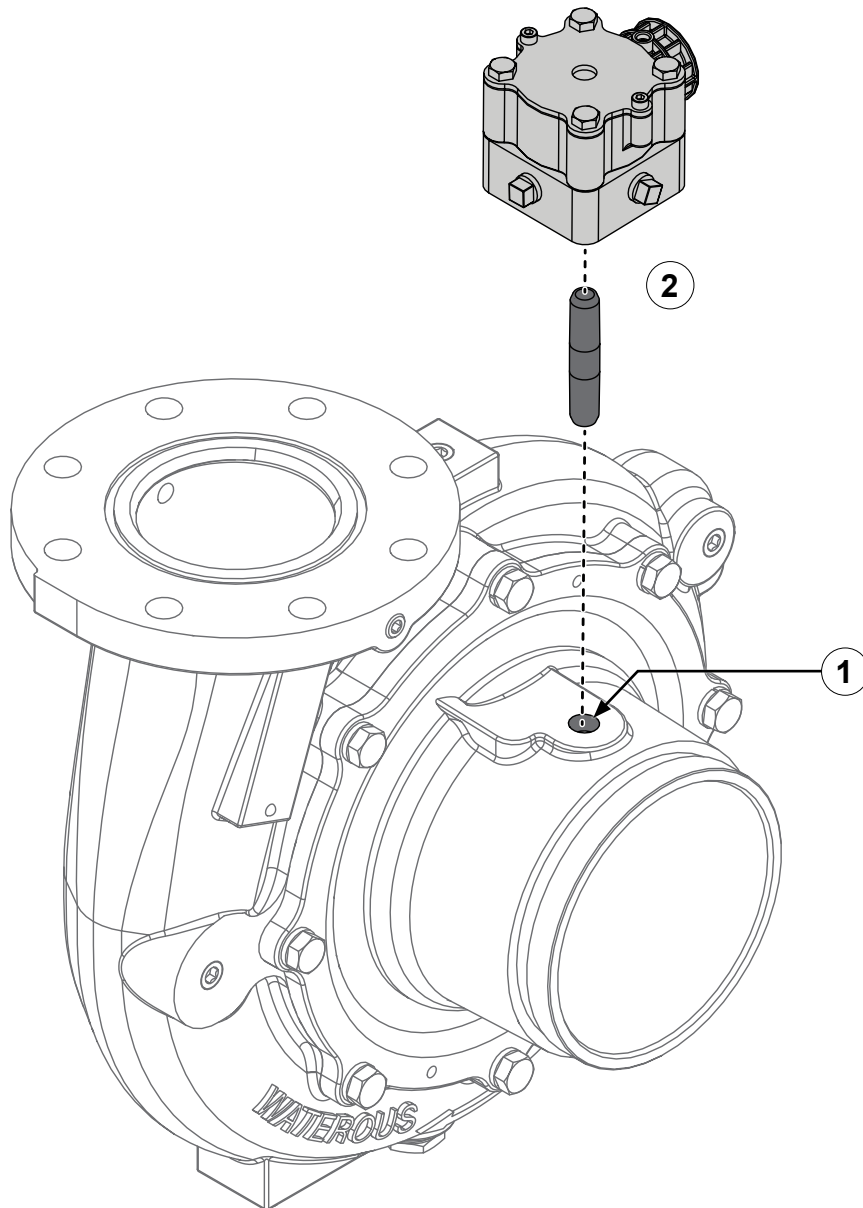

Use the illustration and instructions to install the priming valve. Use appropriate locally sourced air line and fittings. The illustration shows a typical priming valve installation on a typical fire pump—your specific application may differ in appearance. Regardless of appearance, use the following guidelines to install the priming valve in your application:

- The priming valve must be mounted above the air primer. Appropriately locate the priming valve if your application includes operating on hilly terrain.
- The vacuum hose or tubing must allow water to drain from the priming valve to the air primer.
- If additional priming valves are installed on the discharge side of fire pump, know that trapped water can impede proper priming.
- If required, use a hose or tube between the fire pump intake and the priming valve instead of a length of 3/8 NPT pipe.

- 1 Locate a suitable port on the pump intake.
- 2 Install an appropriate length of 3/8 NPT pipe into the port. Then install the priming valve to the pipe.

## Installing the Pressure Switch

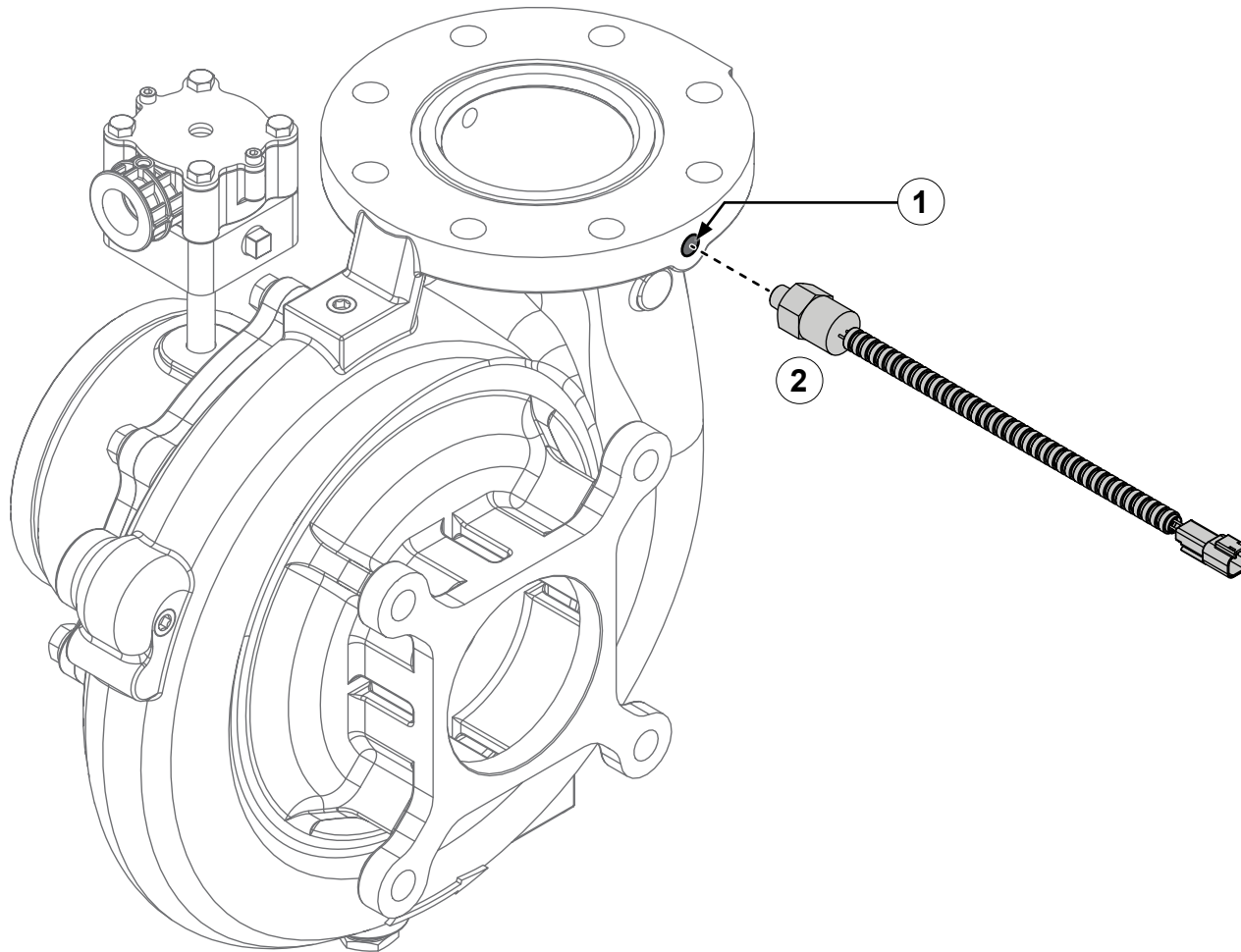

Use the illustration and instructions to install the pressure switch. The pressure switch is only required when operating the pump in auto-prime mode.

- 1 Locate a suitable 1/4 NPT port on the pump discharge.
- 2 Securely install the pressure switch to the pump.

## Installing the Air Primer—Remote Mounting

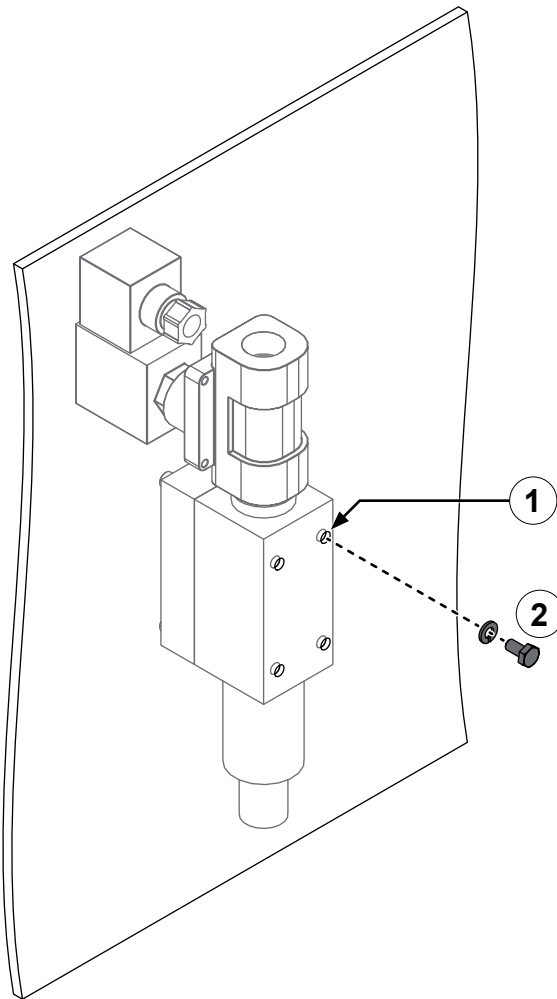

The air primer is typically factory-mounted on the transmission, but it can also be mounted remotely. Use the illustration and instructions to install the air primer. Before you install the air primer, refer to: **"Installation Requirements" on page 33** to determine a proper install location and orientation.

- 1 Drill the mounting holes for the air primer. Refer to: **"Air Primer Mounting Dimensions" on page 37.**
- 2 Use locally sourced mounting hardware to install the air primer.

## Installing the Pressure Protection Valve—Optional

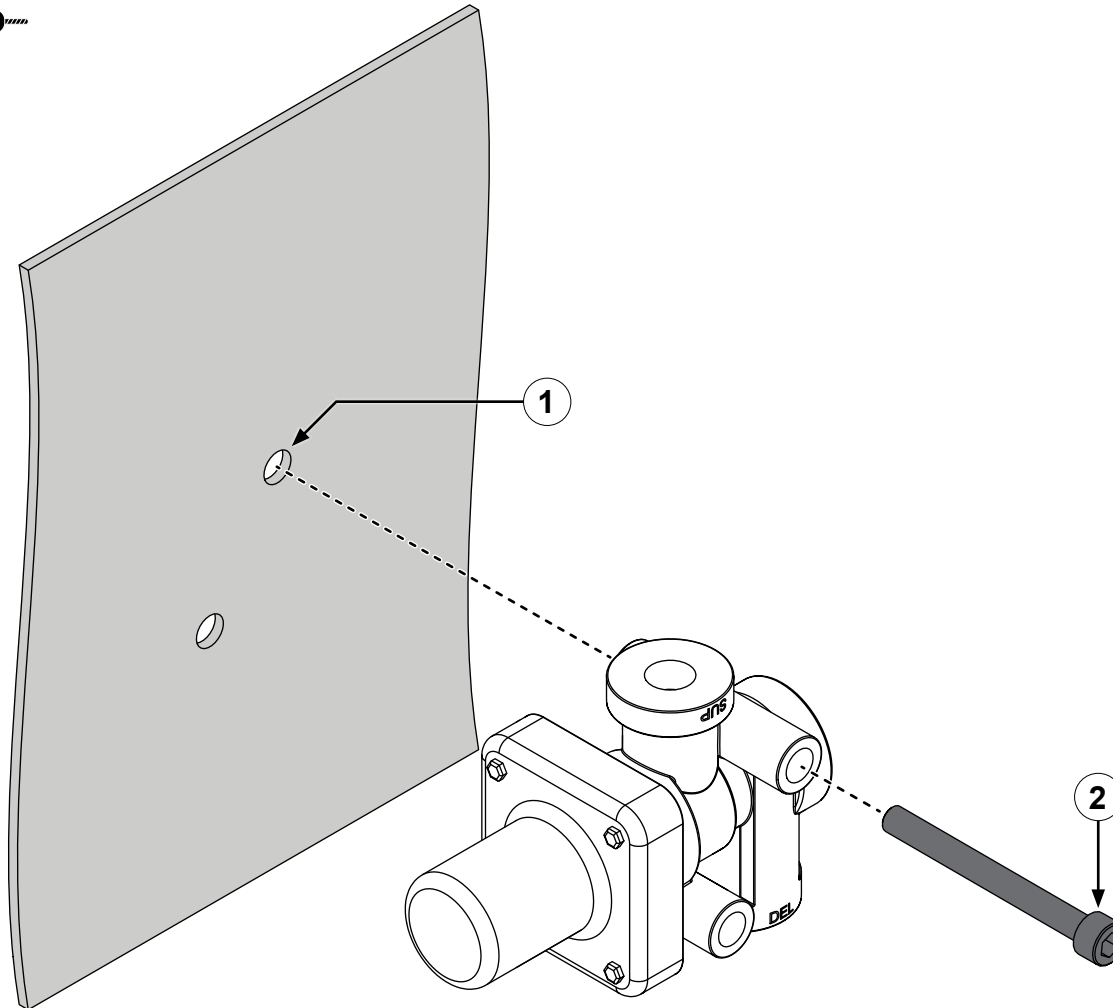

Use the illustration and instructions to install the pressure protection switch.

- 1 Drill the mounting holes for the air primer. Refer to: **"Pressure Protection Valve Mounting Dimensions" on page 38.**
- 2 Use locally sourced mounting hardware to install the pressure protection valve.



## Installing the Priming Valve Solenoid—Optional

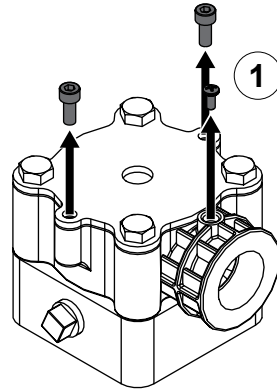

Use the illustration and instructions to install the optional priming valve solenoid.

- 1 Remove the #6 and the M5 screws from the priming valve.

**Note:** The removed screws are no longer needed, repurpose, recycle, or discard them.

- 2 Install the O-ring seals and align the solenoid over the priming valve.

- 3 Use the M5 x 16mm screw to secure the solenoid to the priming valve.

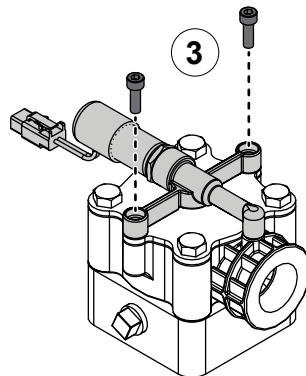
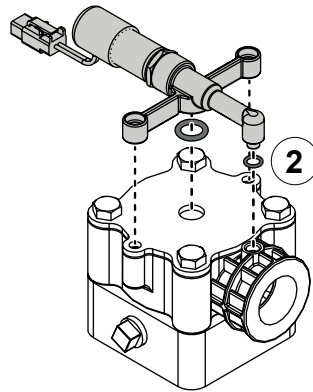

## Connecting the Vacuum Components

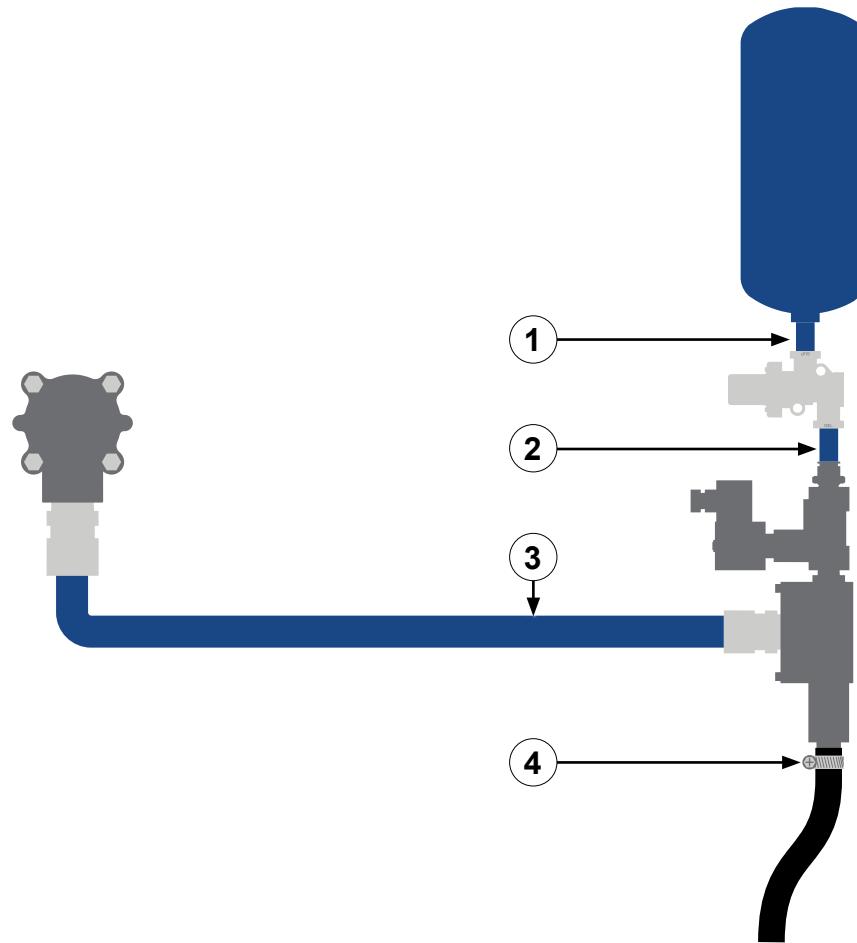

Use the illustration and instructions to connect the vacuum components. Your application may include factory-installed connected components. Otherwise, follow the applicable instructions to connect the components in your application. Use appropriate locally sourced air line and fittings.

- 1 Connect the air-supply from the apparatus to the pressure-protection valve.
- 2 Connect the pressure protection valve to the air primer.
- 3 Connect the air primer to the priming valve.

**Note:** Arrange the hose to allow any water to drain from the priming valve and exit through the air primer.

- 4 Use a 3/4-inch hose and a hose clamp to attach a hose that directs the priming-pump exhaust to a more suitable location.

**Note:** Make sure to use a minimal bend radius and arrange the hose to allow proper draining.

## Connecting the Components

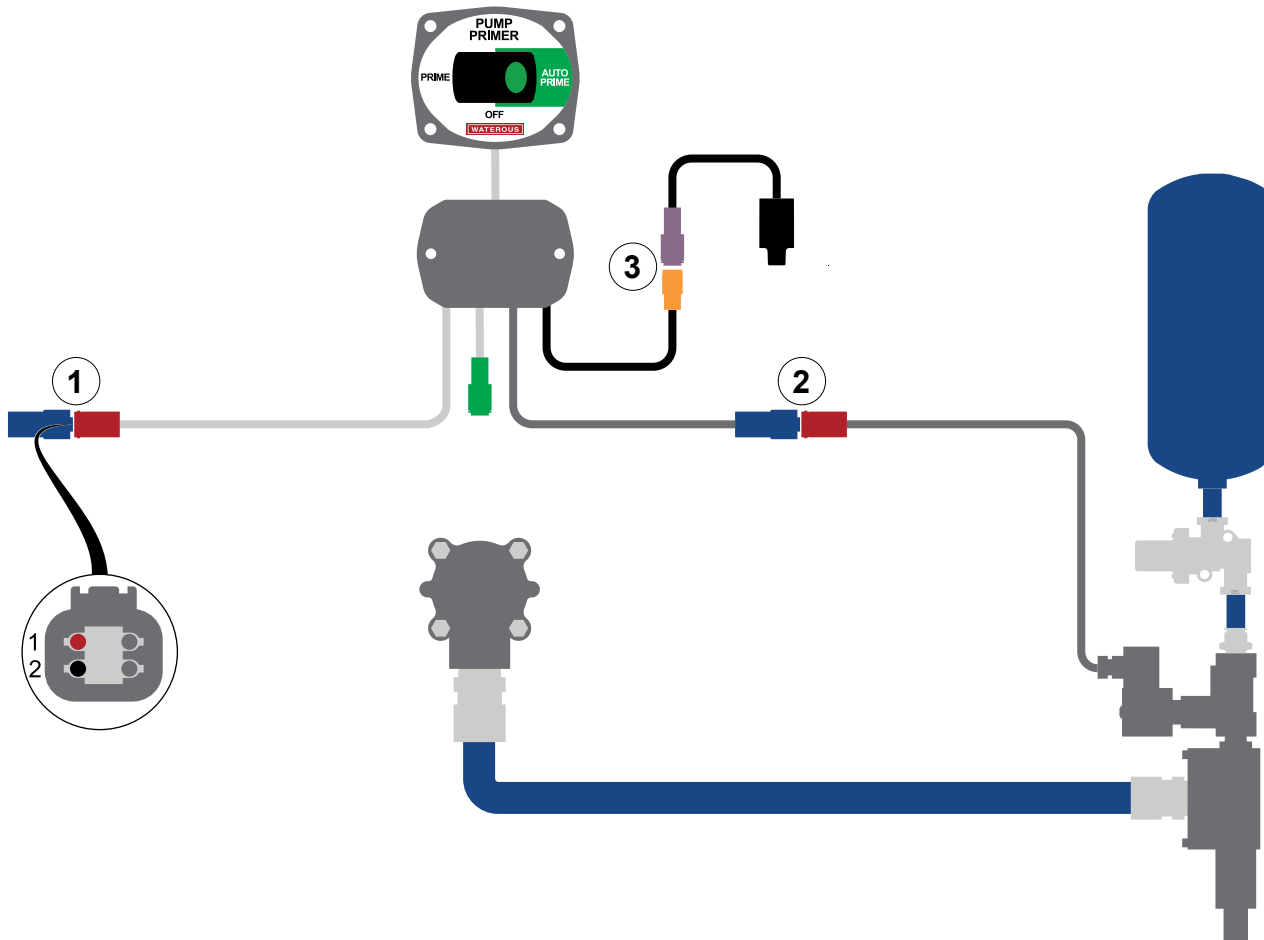

### Auto-Prime Switch

Use the illustration and instructions to connect the switch to the priming electronics.

- 1 Connect power and ground from the apparatus to the DT06-4S connector on the switch:
  - Pin 1=12 V
  - Pin 2=ground
- 2 Connect the priming-pump connector (DT04-4P) on the switch to the air primer connector (DT06-4S).
- 3 Connect the pressure switch connector (DT06-2S) on the switch to the pressure switch connector (DT04-2P).

**Note:** It is recommended to add an additional field wired cable between the panel switch and pressure switch to interconnect the auto priming system with the OK to PUMP circuit. Doing so prevents the system from operating unintentionally and depleting the air reserve. Refer to: **"Additional Field Wired Cable"** on page 56.

## Connecting the Components

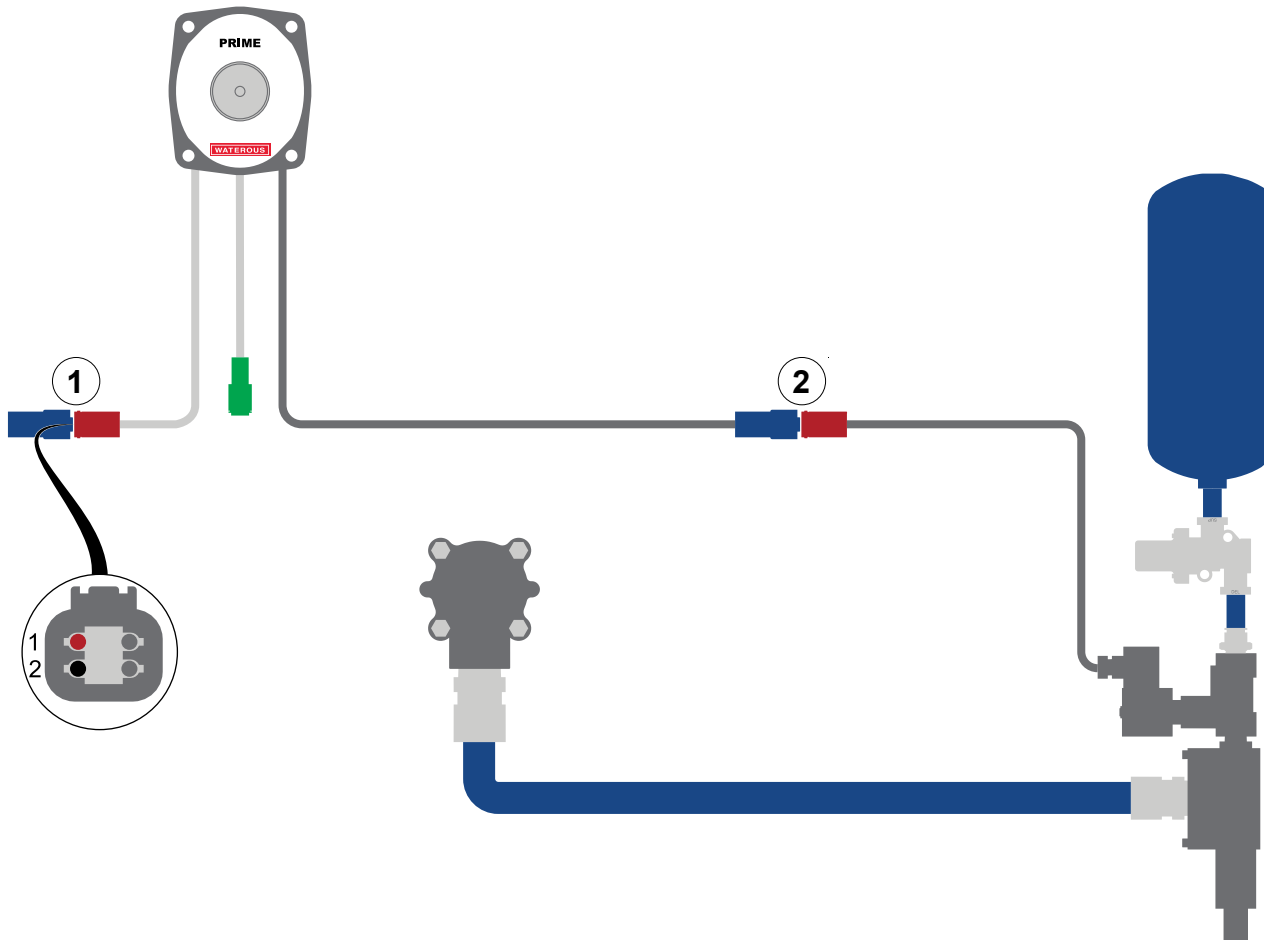

### Standard Push Button Switch

Use the illustration and instructions to connect the switch to the priming electronics.

- 1 Connect power and ground from the apparatus to the DT06-4S connector on the switch:
  - Pin 1=12 V
  - Pin 2=ground
- 2 Connect the priming-pump connector (DT04-4P) on the switch to the air primer connector (DT06-4S).

## Connecting the Components

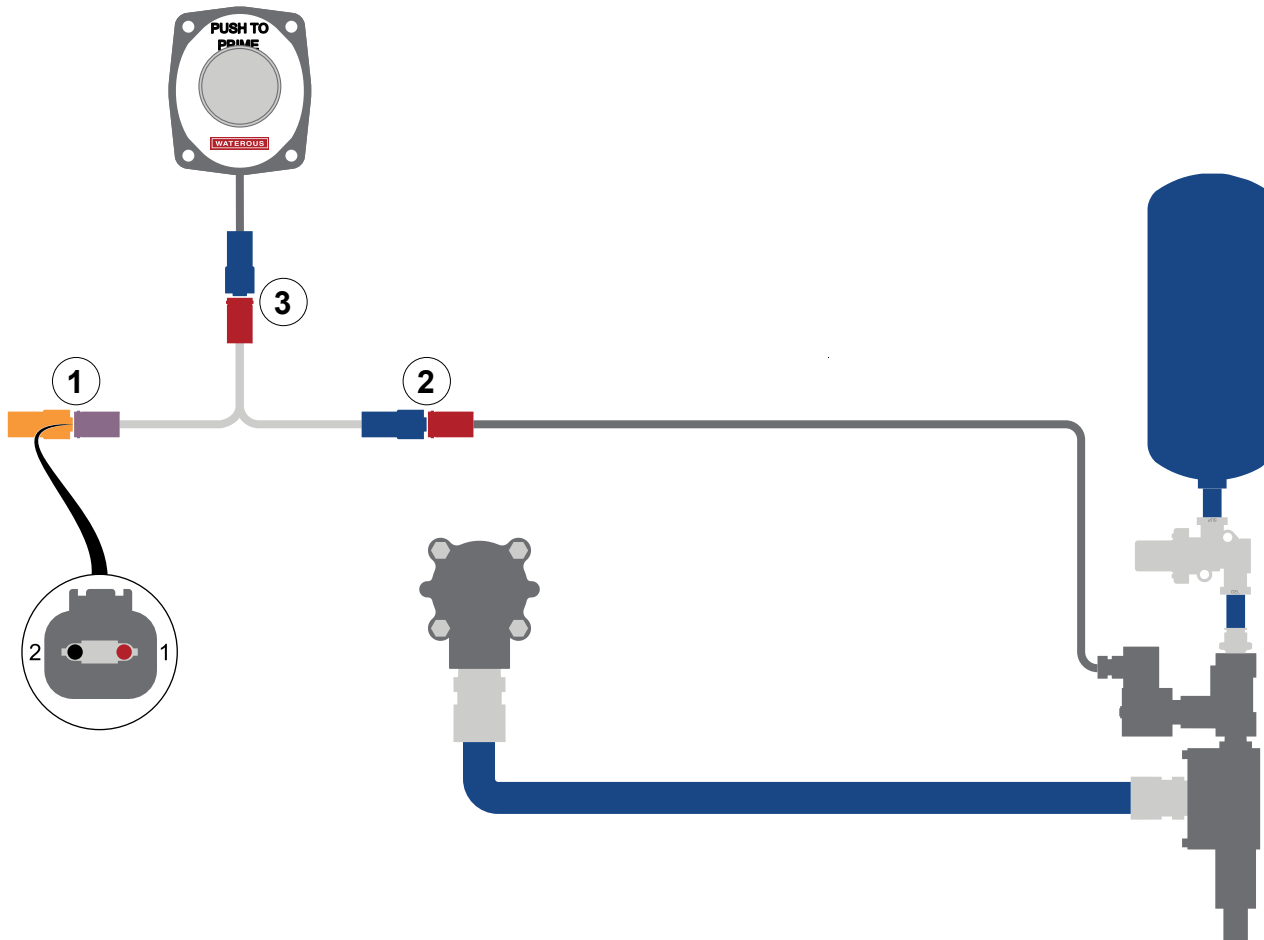

### Oversized Push Button Switch

Use the illustration and instructions to connect the switch to the priming electronics.

- 1 Connect power and ground from the apparatus to the DT04-2P connector on the oversized push button Y-splitter:
  - Pin 1=12 V
  - Pin 2=ground
- 2 Connect the priming-pump connector (DT04-4P) on the oversized push button Y-splitter to the air primer connector (DT06-4S).
- 3 Connect the oversized push button Y-splitter connector (DT06-4S) to the oversized push button switch connector (DT04-4P).

## Connecting the Components

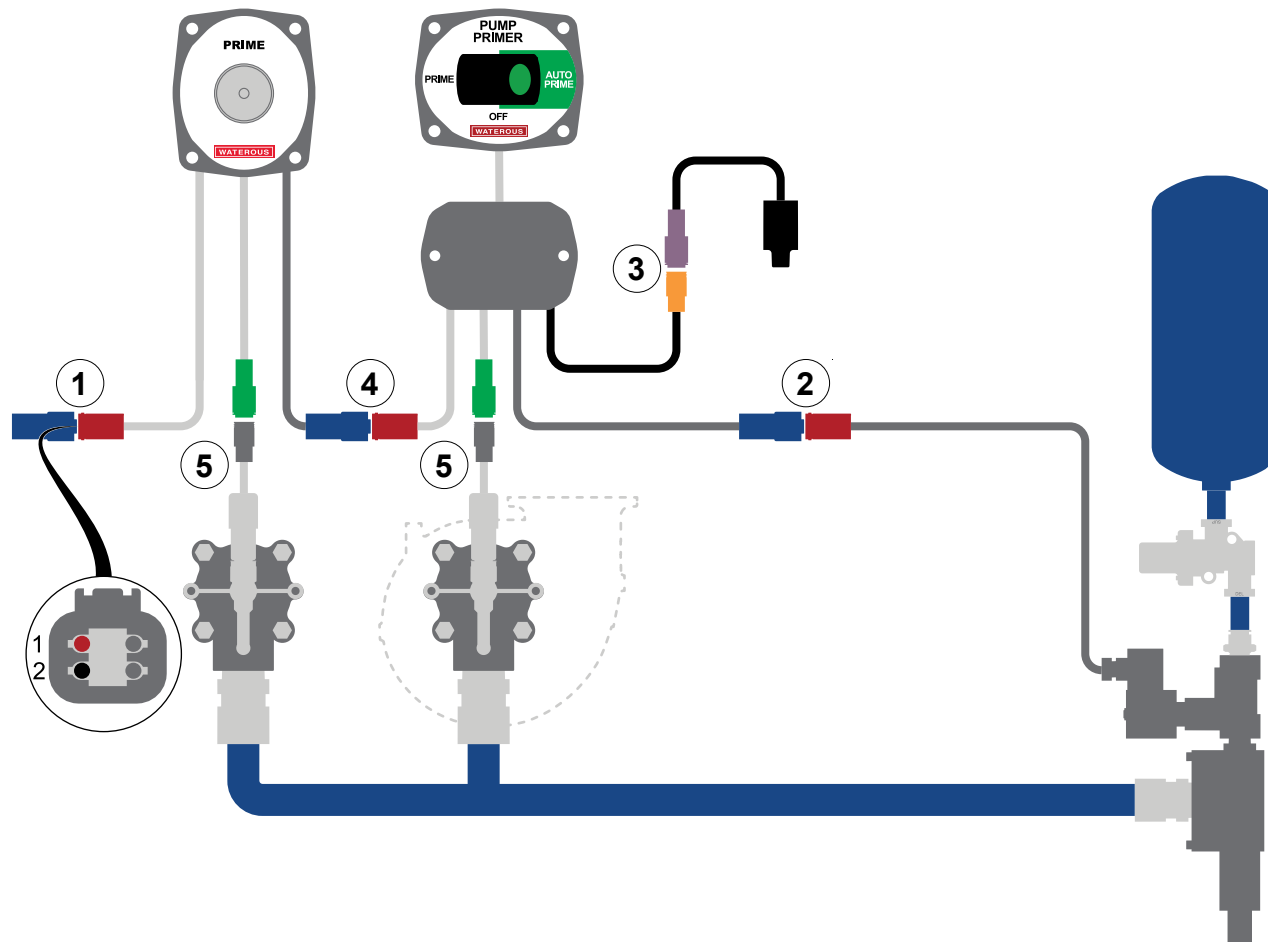

### Mixed Switches with Priming Valve Solenoids

Use the illustration and instructions to connect the switches and the priming electronics.

**Note:** You can connect up to 6 solenoid controlled priming valves, each with a dedicated switch, in your application. Also, it is recommended that you connect the auto-prime switch to the main pump priming valve.

1 Connect power and ground from the apparatus to the DT06-4S connector on the switch:

- Pin 1=12 V
- Pin 2=ground

2 Connect the priming-pump connector (DT04-4P) on the switch to the air primer connector (DT06-4S).

3 Connect the pressure switch connector (DT06-2S) on the switch to the pressure switch connector (DT04-2P).

**Note:** It is recommended to add an additional field wired cable between the panel switch and pressure switch to interconnect the auto priming system with the OK to PUMP circuit. Doing so prevents the system from operating unintentionally and depleting the air reserve. Refer to: **"Additional Field Wired Cable"** on page 56.

4 Connect the air primer connector (DT04-4P) from the previous switch to the power connector (DT06-4S) on the next switch.

5 Connect the priming valve solenoid connector (DTM04-2P) on the switch to the solenoid connector (DTM06-2S).

## Connecting the Components

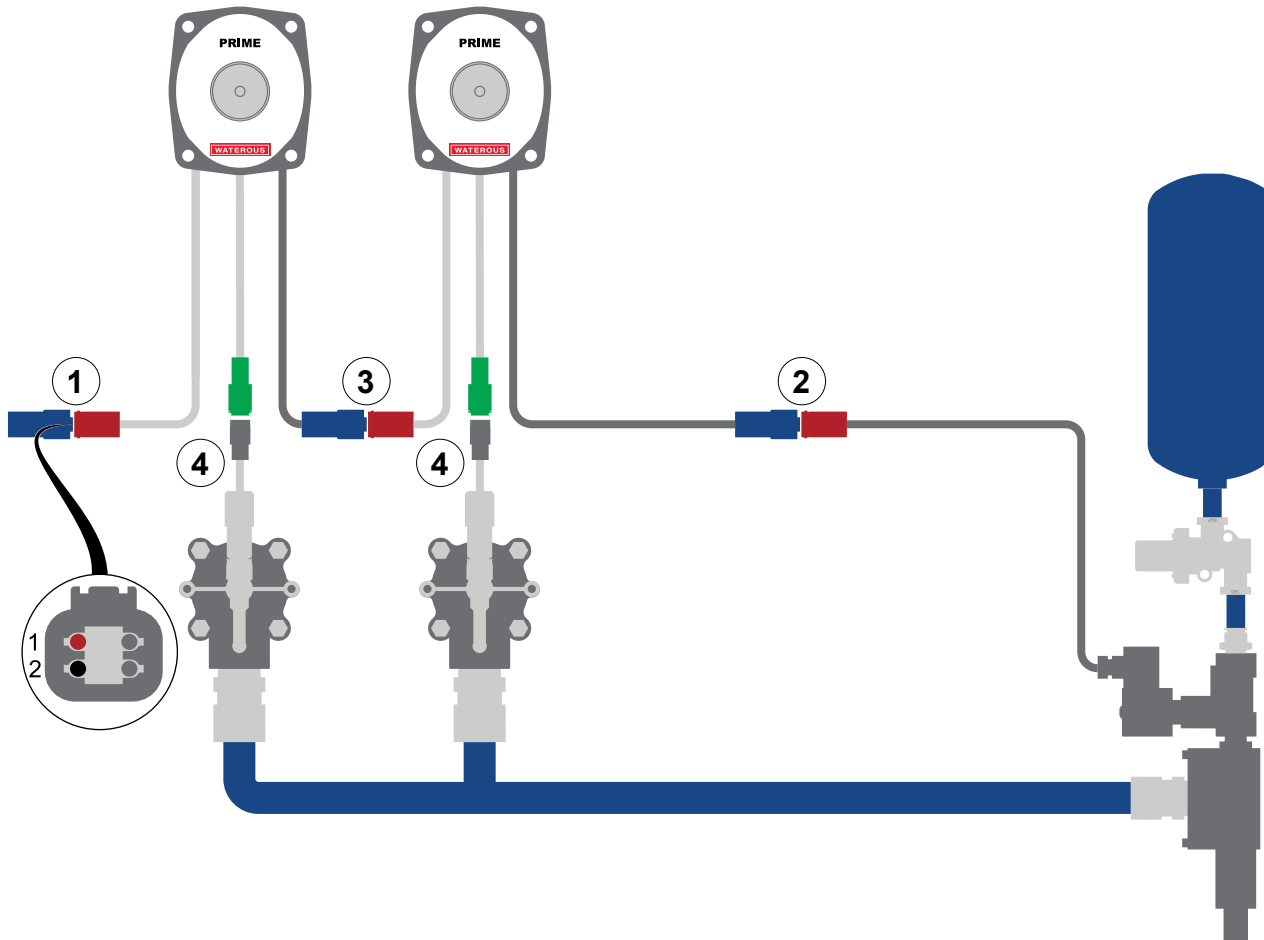

### Standard Switches with Priming Valve Solenoids

Use the illustration and instructions to connect the switches and the priming components.

**Note:** You can connect up to 6 solenoid controlled priming valves, each with a dedicated switch application.

- 1 Connect power and ground from the apparatus to the DT06-4S connector on the switch:
  - Pin 1=12 V
  - Pin 2=ground
- 2 Connect the priming-pump connector (DT04-4P) on the switch to the air primer connector (DT06-4S).
- 3 Connect the air primer connector (DT04-4P) from the previous switch to the power connector (DT06-4S) on the next switch.
- 4 Connect the priming valve solenoid connector (DTM04-2P) on the switch to the solenoid connector (DTM06-2S).

## Connecting the Components

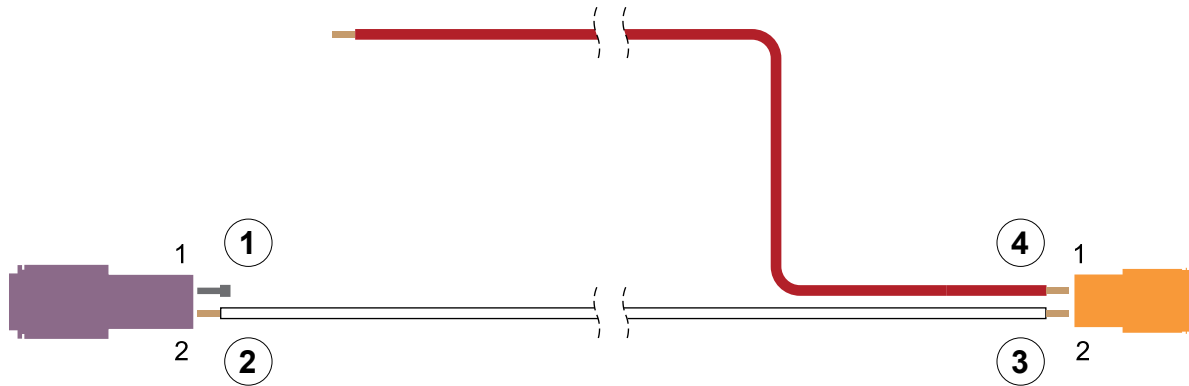

### Additional Field Wired Cable

Use the illustration and instructions to connect the additional field wired cable to the panel switch and pressure switch. Use appropriate locally sourced materials to assemble the additional field wired cable.

**Note:** Lengths and colors of wires used may vary depending on your application.

- 1 Plug pin 1 of a DT04-2P connector.
- 2 Connect white wire to pin 2 of the DT04-2P connector.
- 3 Connect white wire to pin 2 of a DT06-2S connector.
- 4 Connect red wire to pin 1 of the DT06-2S connector.
- 5 Connect the field wired cable (DT04-2P) to the panel switch (DT06-2S).
- 6 Connect the field wired cable (DT06-2S) to the pressure switch (DT04-2P).
- 7 Connect red wire from pin 1 of the DT06-2S connector of the additional field wired cable to the OK to PUMP circuit.

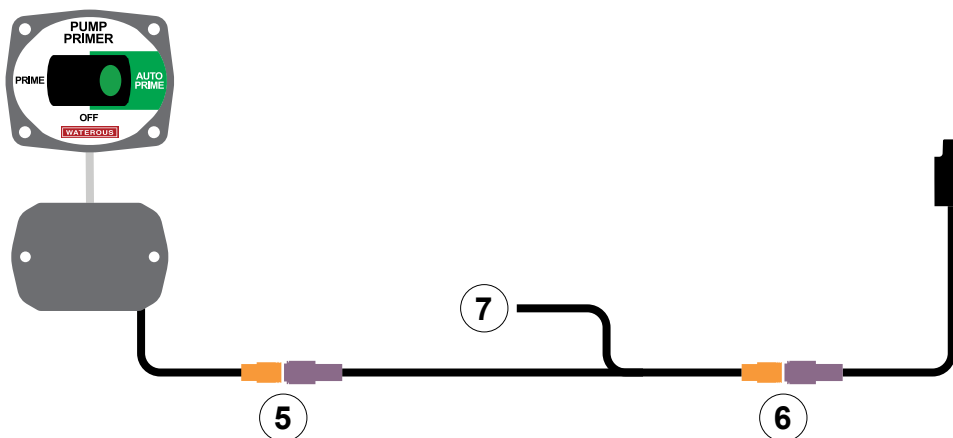



## Basic Operation Overview

The Venturis air priming system displaces air within the plumbing with water that primes the pump before operation.

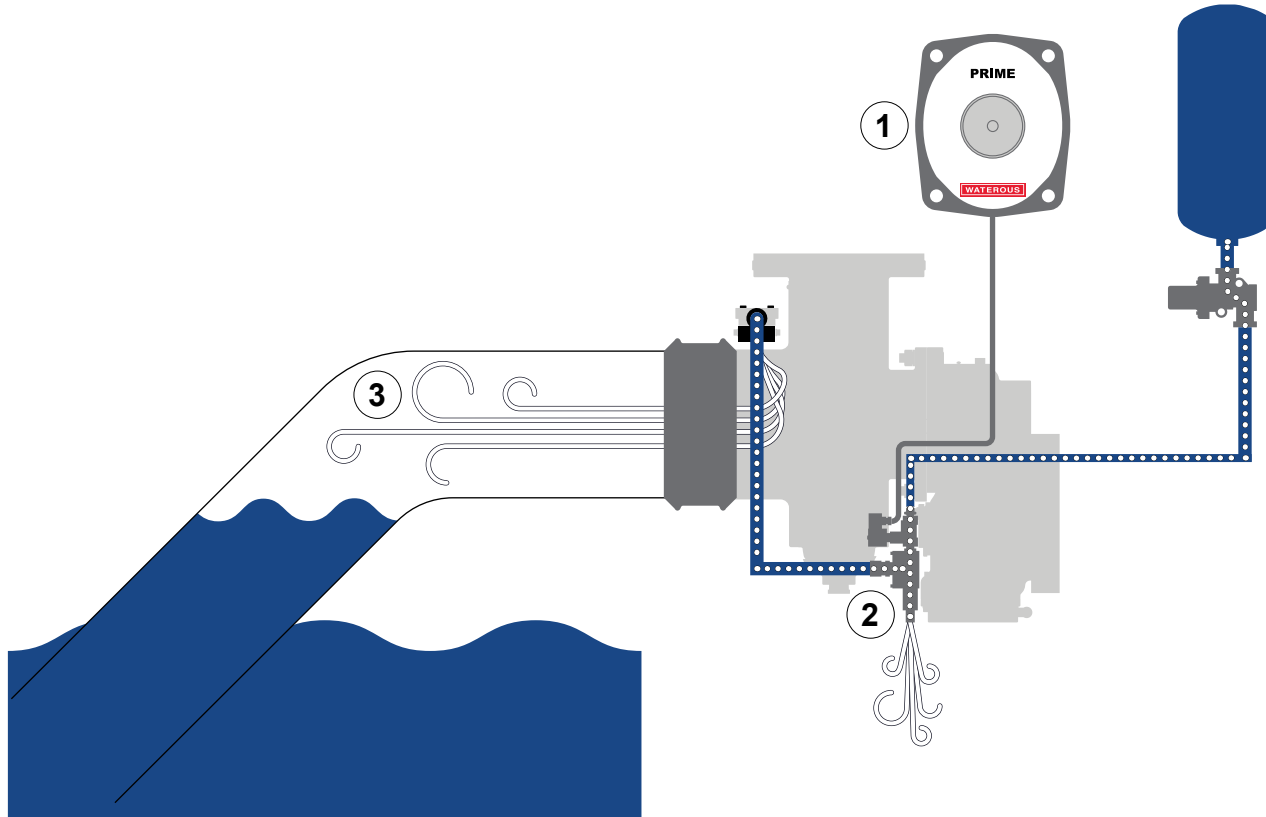

Use the illustration and instructions to understand the general overview about priming operation.

- 1 When you press the *PRIME* button, it opens the solenoid valve that allows compressed air to flow through the air primer.
- 2 Air exhausting through the air primer draws air in the plumbing through the priming valve on the pump.
- 3 As air is displaced, water is drawn into the pump to prime it.

## Venturis Air Primer Operation Overview

The Venturis air primer uses the venturi effect to prime the pump.

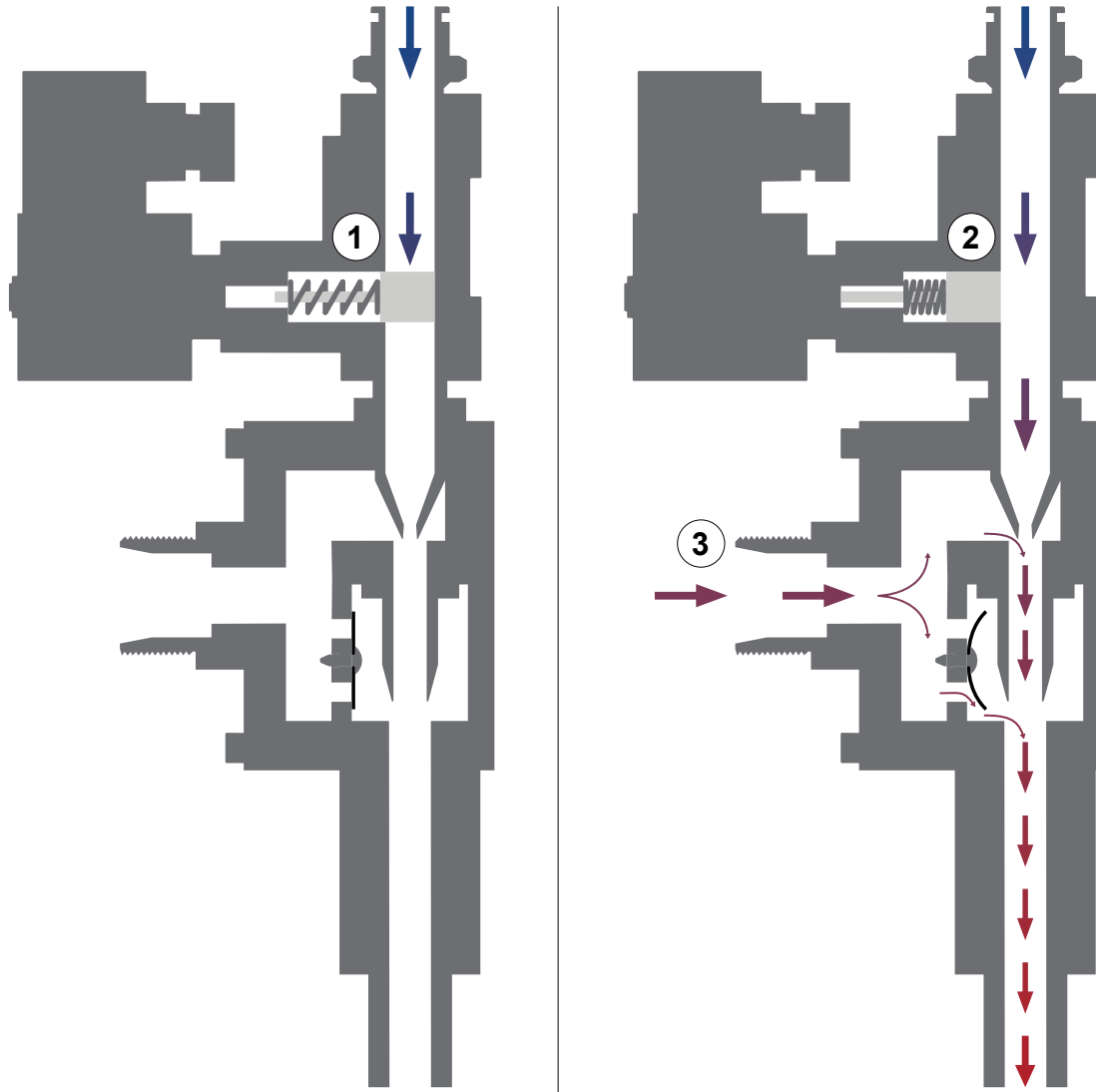

Use the illustration and instructions to understand the principles of operation of the air primer.

- 1 When not in use, a closed solenoid valve on the air primer assembly prevents operation.
- 2 When the solenoid valve is opened, compressed air flows through the inner-workings of the air primer.
- 3 As air passes through the inner-workings of the air primer, it creates a vacuum that displaces the air in the pump with water that primes the pump before operation.

## Auto-Prime Switch Priming

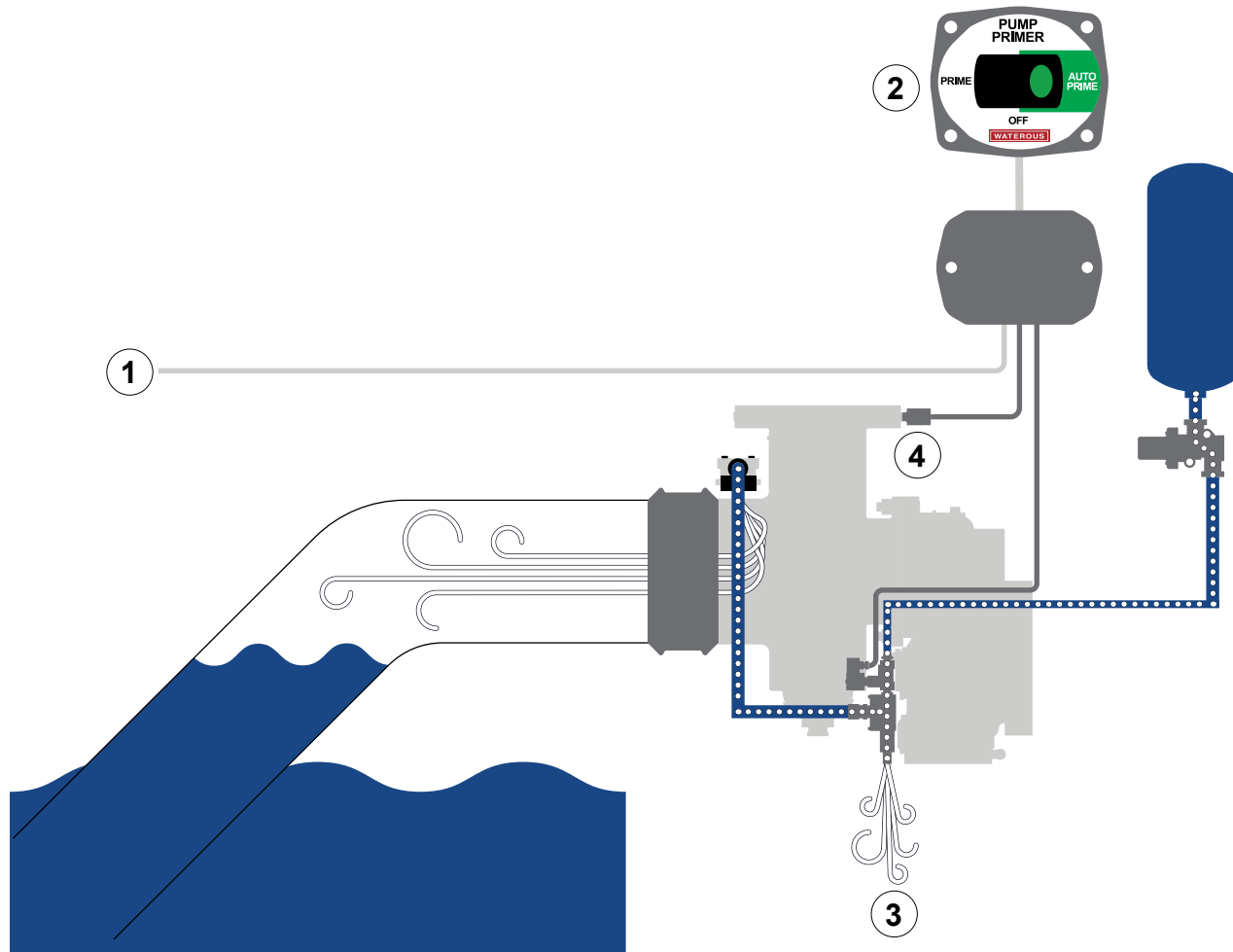

Use the illustration and instructions to operate the priming system using the auto-prime switch in manual and auto-prime mode.

- 1 Once power is applied, the priming system is enabled.
- 2 On the auto-prime switch, you can manually prime the fire pump by pressing and holding the *PRIME* side of the switch. Alternatively, you can enable the auto prime mode by pressing the *AUTO PRIME* side of the switch.
- 3 In either mode, the air primer begins evacuating the air in the intake which is replaced with water, this primes the fire pump.
- 4 In auto-prime mode, the pressure switch detects when priming is complete and stops the process.

## Standard Switch Priming

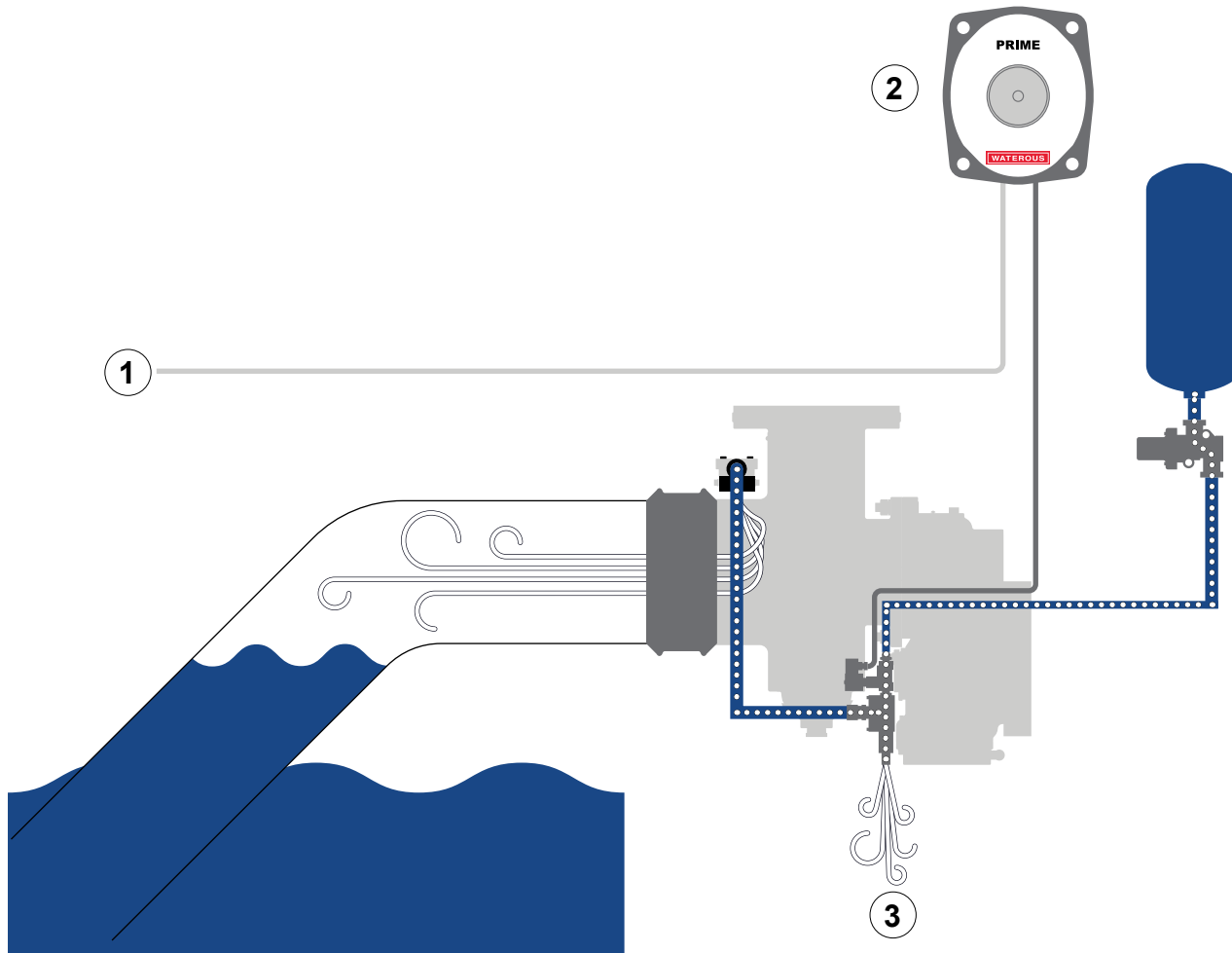

Use the illustration and instructions to operate the priming system using the standard switch.

- 1 Once power is applied, the priming system is enabled.
- 2 Press and hold the prime button until the priming process is complete.
- 3 While priming, the air primer begins evacuating the air in the intake which is replaced with water, this primes the water pump.

## Priming Multiple Locations

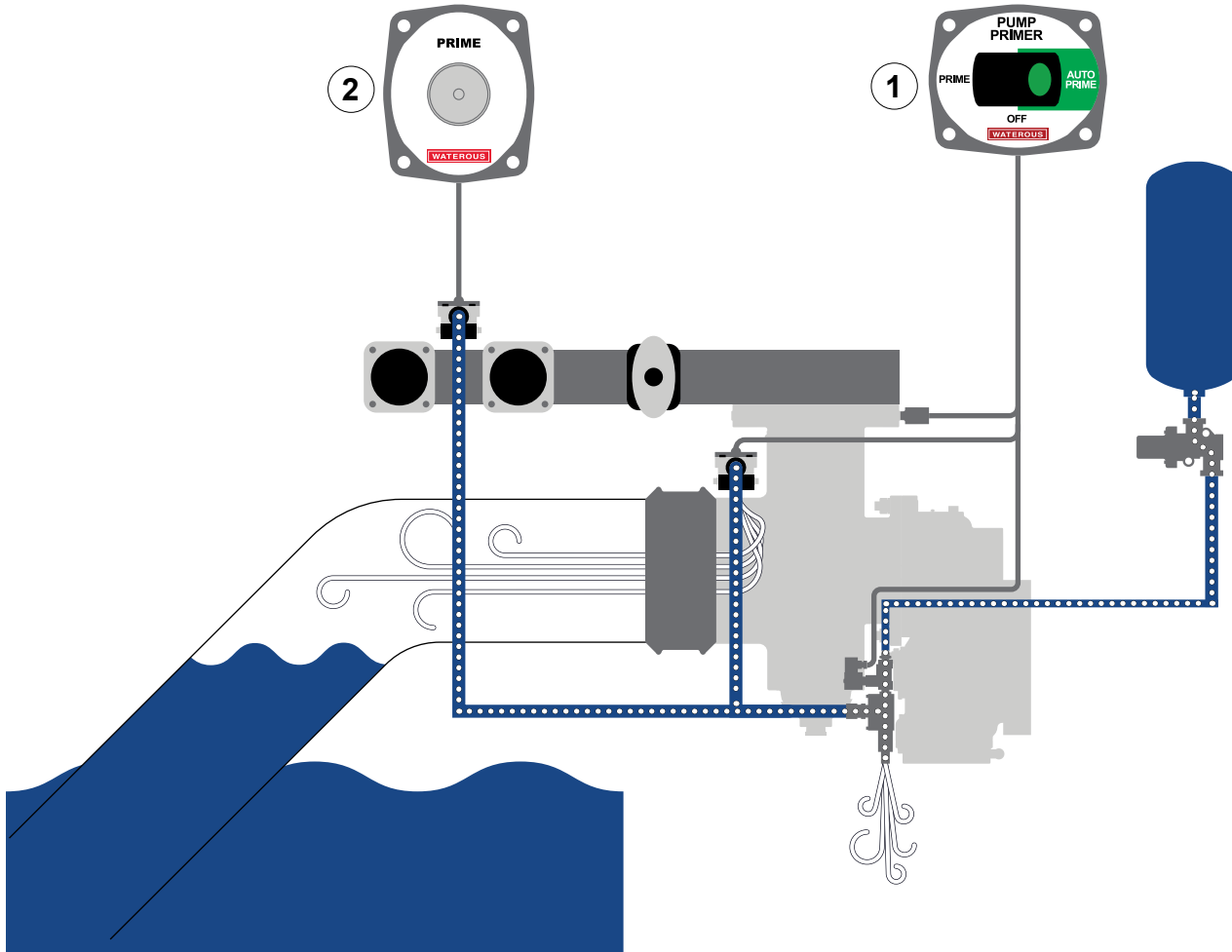

Use the illustration and instructions to prime an application with multiple priming valves. Know that each priming valve should be isolated and operated independently.

- 1 Use the auto-prime switch to prime the main pump priming valve on the pump.
- 2 Individually prime each remaining location as required.

## Maintenance Schedule

Perform the following procedures at the recommended intervals at a minimum. Environmental conditions determine the maintenance intervals. Inspect the components frequently, and create a maintenance schedule suitable to your application and environmental conditions. Replace wear components with equivalent components.

| Operation               | Before Initial Operation | Monthly | 12 Months | As Required | Comment  |
|-------------------------|--------------------------|---------|-----------|-------------|--|
| Verify proper operation | X                        |         |           |             |  |
| Inspect O-ring          |                          |         | X         |             | Replace with equivalent part if degraded or damaged. |
| Inspect the seal        |                          |         | X         |             | Replace with equivalent part if degraded or damaged. |
| NFPA testing            |                          |         | X         |             |  |

## Service Tool—Secondary Nozzle Removal Tool

The secondary nozzle removal tool allows you to remove the secondary nozzle. The tool is available through Waterous, or use the illustration to make the tool.

Part Number: 53780

Material: Aluminum Tube Stock

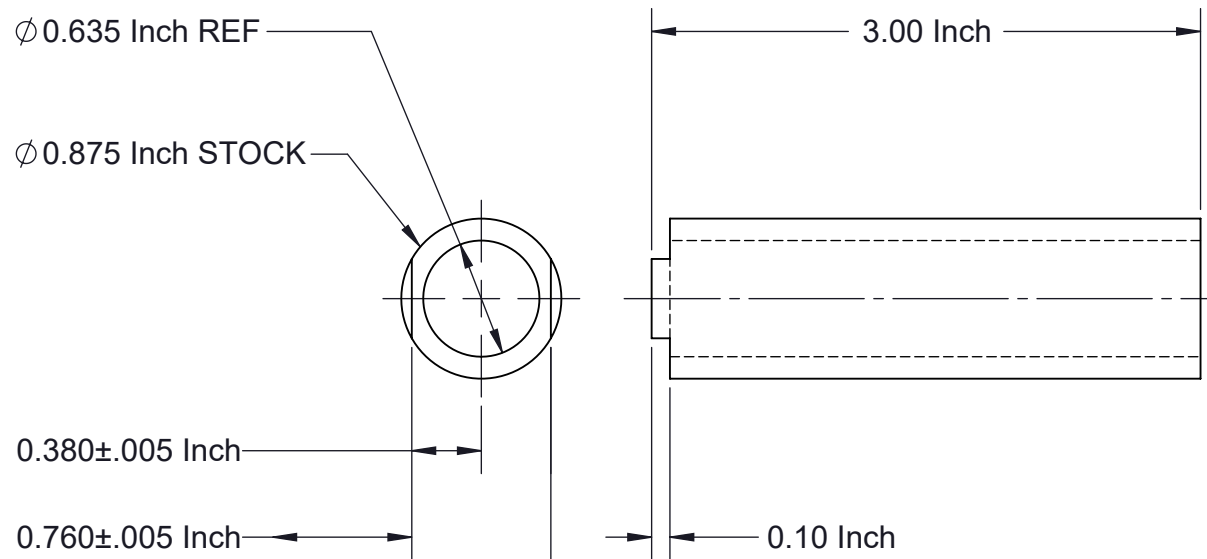

## Servicing the Vacuum Pump

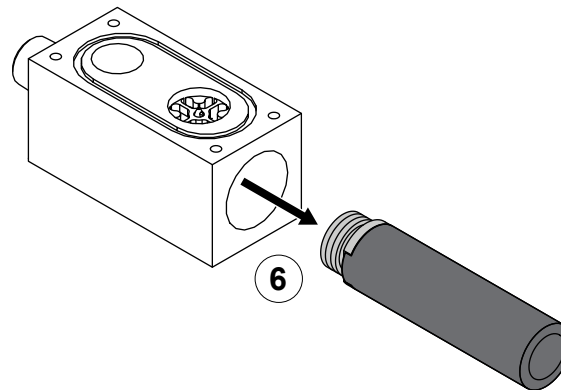
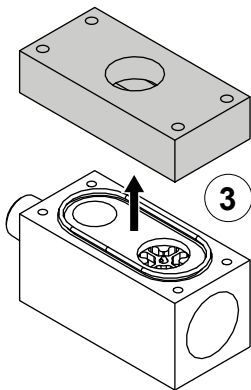
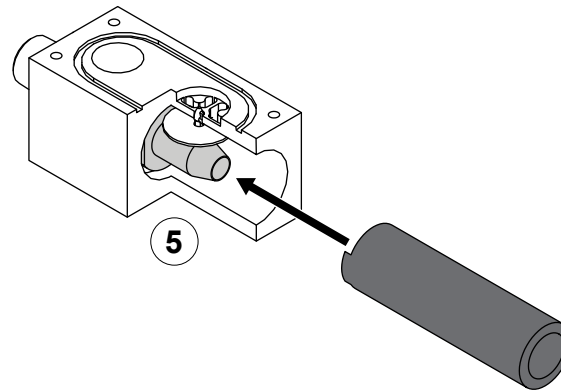
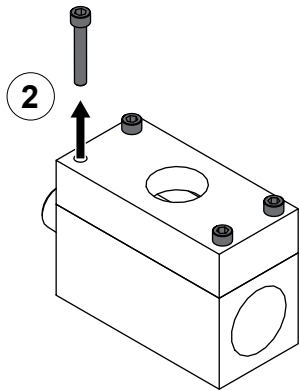
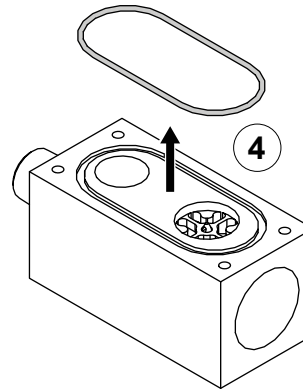
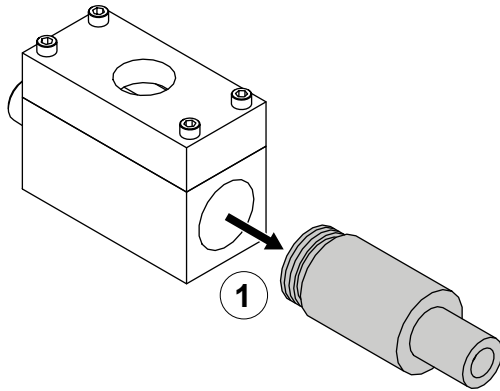

### Removing Components

Use the illustration and instructions to service the air primer. Before beginning the procedure, removing any debris on and around the air primer to prevent contaminating the interior of the air primer.

- 1 Remove and set aside the outlet nozzle.
- 2 Remove and set aside the cover screws.
- 3 Remove and set aside the cover.
- 4 Remove and inspect the O-ring. Replace the O-ring with an equivalent if it is degraded or damaged.
- 5 Use the service tool to remove the secondary nozzle.
- 6 Remove and set aside the secondary nozzle.



## Servicing the Vacuum Pump

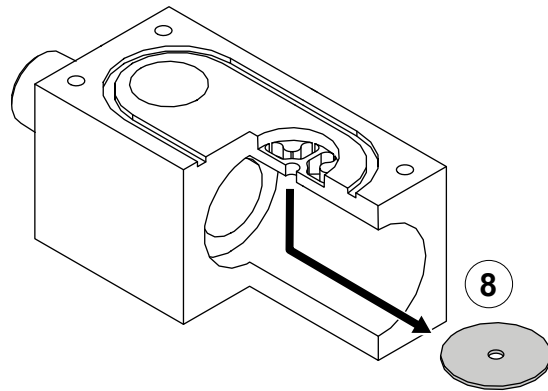
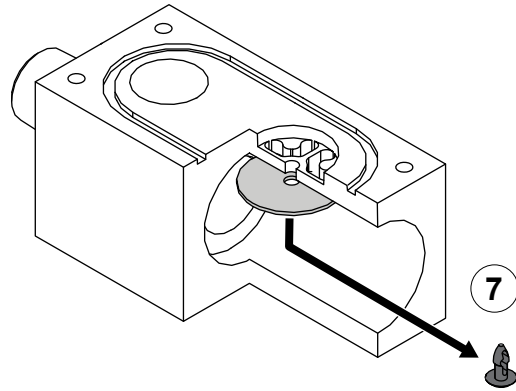

### Removing Components

Use the illustration and instructions to service the air primer.

- 7 Remove and inspect the push-in rivet. Replace the push-in rivet with an equivalent if it is degraded or damaged.
- 8 Remove and inspect the seal. Replace the seal with an equivalent if it is degraded or damaged.

## Servicing the Vacuum Pump

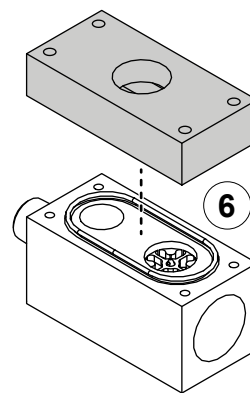
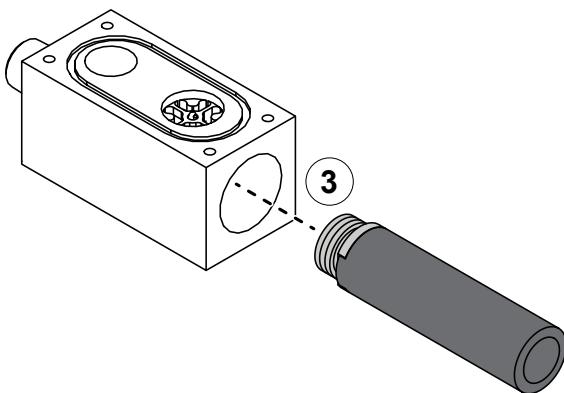
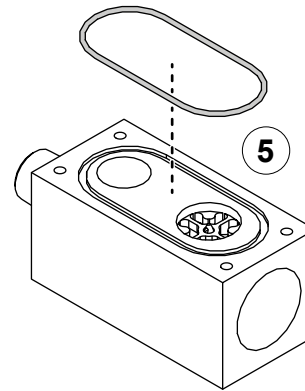
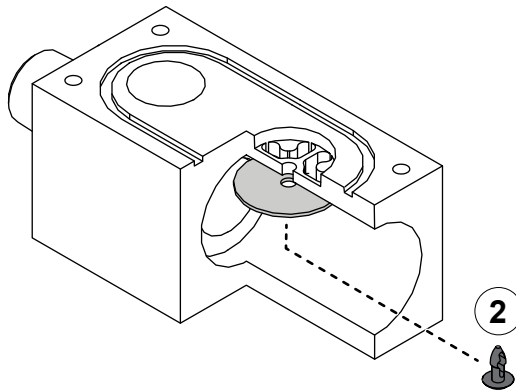
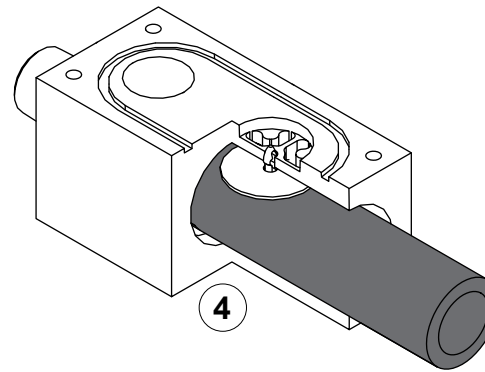
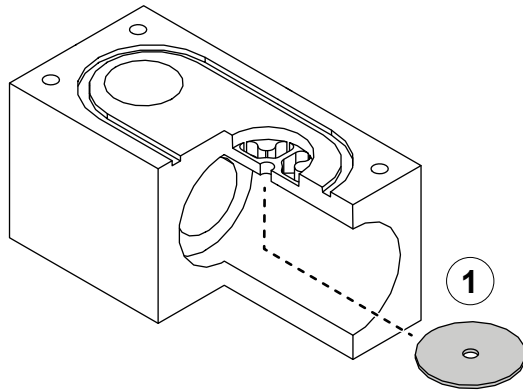

### Installing Components

Use the illustration and instructions to service the air primer. If required, use equivalent part replacements.

**Note:** Make sure that you remove any debris from the interior of the pump to prevent any performance degradation.

- 1 Position the seal over the opening.
- 2 Install the push-in rivet to secure the seal.
- 3 Insert the secondary nozzle into the service-tool.
- 4 Use the service-tool to install the secondary nozzle.
- 5 Install the O-ring.
- 6 Align the cover over the O-ring.

## Servicing the Vacuum Pump

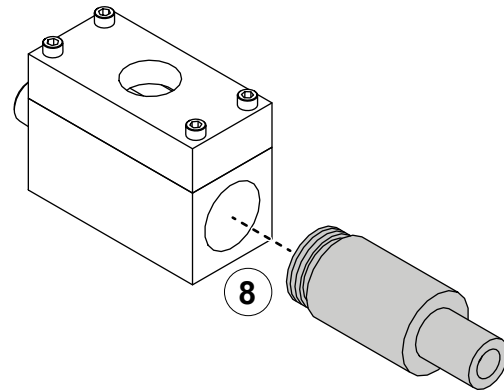
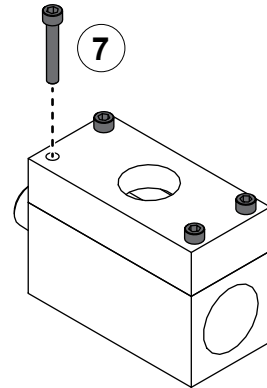

### Installing Components

Use the illustration and instructions to service the air primer. If required, use equivalent part replacements.

7 Use the screws that you removed earlier to secure the cover to the body.

8 Install the outlet nozzle to the body.

**WATEROUS**

Waterous Company  
125 Hardman Avenue South  
South Saint Paul, MN 55075  
(651) 450-5000  
[www.waterousco.com](http://www.waterousco.com)