

# CZ Series Centrifugal Fire Pumps

# Operation and Maintenance

Form No.	Section	Issue Date	Rev. Date
F-1031	2111	04/90	6/4/20

## Table of Contents

<b>Safety Information</b> .....	1, 2
<b>General Description</b> .....	3
Components .....	3
Options .....	3
<b>Operating Instructions</b> .....	4
Pumping from Water Tank.....	4
Pumping from Hydrant or in Relay .....	5
Pumping from Draft .....	6
Fire Hose Testing.....	7
<b>Maintenance</b> .....	8
Corrosion Protection.....	8
Optional Intake Screens.....	8
Optional Anodes .....	8
Lubrication .....	9
Mechanical Seal .....	9
Overheat Protection Manager (OPM) .....	9

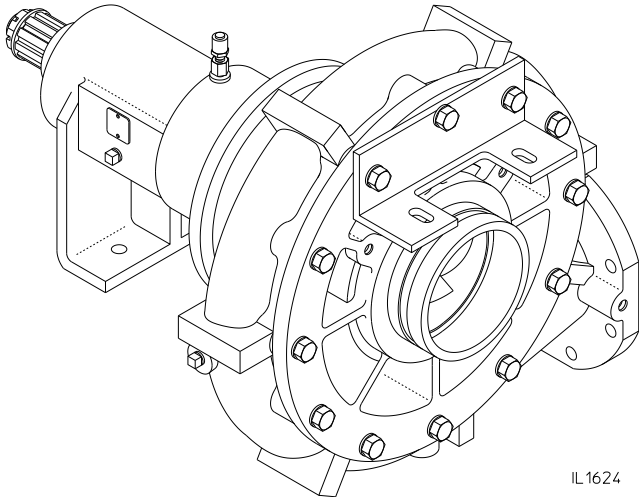

## Illustrations

Figures:

1. CZ Series Fire Pump .....	3
2. CZU Series Fire Pump .....	3
3. Zinc Intake Screens .....	8
4. Bolt-on Anodes .....	8
5. Threaded Anodes .....	8
6. CZ Pump.....	9
7. CZ and CZU Pump.....	10



Read through the safety information and operating instructions carefully before using your Waterous Fire Pump.

**WATEROUS**

Visit us at [www.waterousco.com](http://www.waterousco.com)

## Safety Information



Read through the safety information and operating instructions carefully before using your Waterous Fire Pump.

### **WARNING**

Death or serious personal injury might occur if proper operating procedures are not followed. The pump operator, as well as individuals connecting supply or discharge hoses to the apparatus must be familiar with these pump operating instructions as well as other operating instructions and manuals for the apparatus, water hydraulics and component limitation.

### **WARNING**

#### **Pressure Hazard. May result in personal injury.**

Prior to connection or removal of hoses, caps or other closures with pump intake or pump discharge connections, relieve pressure by opening drains or bleeder valves. Bleeder valves should also be used while filling a hose connected to an intake with water.

### **WARNING**

#### **Scalding Water Hazard. May result in serious burns.**

When operating the pump, be sure to open at least one discharge valve slightly to prevent the pump from overheating. If the pump runs for a few minutes completely closed, it may heat the water enough to scald someone when the valve is opened. Overheating can damage the packing, seals and other pump parts. If the apparatus builder has installed a by-pass system or other provision designed to prevent overheating, opening a discharge valve may be unnecessary.

## Safety Information



Read through the safety information and operating instructions carefully before using your Waterous Fire Pump.



### WARNING

**Hose Testing Hazard. May result in serious personal injury.**

Due to a potential for catastrophic hose failure during service testing of fire hose, it is vital that safety precautions be taken to prevent exposure of anyone to this danger. Fire pumps on fire department apparatus are not designed for and should not be used for service testing of fire hoses. Hose testing machines should be used for service testing of fire hoses.



### WARNING

**Pressure Hazard. May result in serious personal injury.**

If a fire pump on a fire department apparatus is used for service testing of fire hoses, the procedures in NFPA 1962 **MUST be followed** including the use of a fire department gate valve with a ¼-inch (6 mm) hole drilled through the gate installed between the fire apparatus discharge outlet and the hose test layout to prevent a volume surge from the pump in the event a hose bursts during testing.



### WARNING

**Scalding Water Hazard. May result in serious burns.**

If a fire pump on a fire department apparatus is used for service testing of fire hoses, pump discharge water must be circulated through a by-pass system or discharged through a slightly open discharge valve, or some other provision must be used to prevent overheating. If the pump runs for a few minutes without adequate flow through the pump, water may be heated enough to scald someone when a valve is opened.

# Introduction

This instruction contains the information needed for operation and maintenance of CZ Series centrifugal pumps.

## General Description

The CZ Series centrifugal fire pumps are direct-drive, single stage, vertically-split and designed to operate from a water tank, hydrant or from draft. CZ Series pumps are equipped with a 5" intake and are capable of pumping 950 gpm at 260 psi (3600 l/m @ 18 bar). CZU Series pumps are equipped with a 6" intake and are capable of pumping 1500 gpm at 250 psi (5675 l/m @ 17.3 bar).

**OPERATION LIMITS: Do not operate pump beyond max. pressure (350 psi) or max. speed (4000 rpm for CZ; 4200 rpm for CZU).**

**Fail to do that may result in personal injury or premature pump failure.**

## Components

### Body Assembly

This assembly includes the body, intake and discharge adapters, bearing housing and related parts. The body and adapters are either cast iron or bronze.

### Impeller Shaft Assembly

This assembly consists of a bronze impeller mounted on a stainless steel shaft with wear rings, mechanical seal and related parts. The impellers are balanced and the impeller shaft is supported by ball bearings.

### Mechanical Seals

#### CZ

The mechanical seal consists of a flat, highly polished (lapped), spring-fed carbon ring that is sealed to and ro-

tates with the impeller shaft. It presses against a highly polished (lapped), silicone carbide, stationary ring that is sealed in the pump body. This seals the shaft and prevents air from entering and water from leaving. A mechanical seal does not leak or drip water, even when pumping.

#### CZU

The mechanical seal consists of a flat, highly polished (lapped), spring-fed carbon ring that is seated in the pump volute. It presses against a highly polished (lapped), stainless steel ring that is seated in and rotates with the impeller. This seals the shaft and prevents air from entering and water from leaving. Additional O-rings around the washer help keep the shaft dry during pump operation. A mechanical seal does not leak or drip water, even when pumping.

## Options

### Intake Screens

Zinc die cast screens are normally used in the intake fittings, with brass screens available optionally. Although the screens are chemically treated (coated) to inhibit corrosion, the water being pumped may still corrode the screens. Such corrosion is "sacrificial"; that is, it will help prevent corrosion in the rest of the pump the same way the magnesium anodes protect the metal parts of a water heater.

### Anodes

As additional corrosion protection for iron body pumps, Waterous has anodes available to fit any unused opening in the intake fitting. Anodes provide an additional sacrificial surface to the water to supplement the intake screens.

### Overheat Protection Manager (OPM)

The Overheat Protection Manager (OPM) acts as a safety device by releasing hot water to the ground or back to the water tank from the discharge area of the pump.

Figure 1. CZ Series Fire Pumps

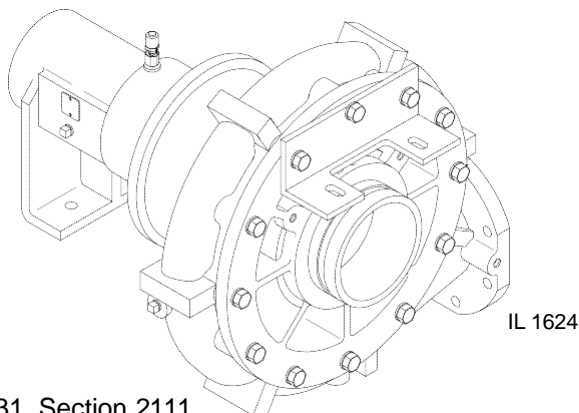
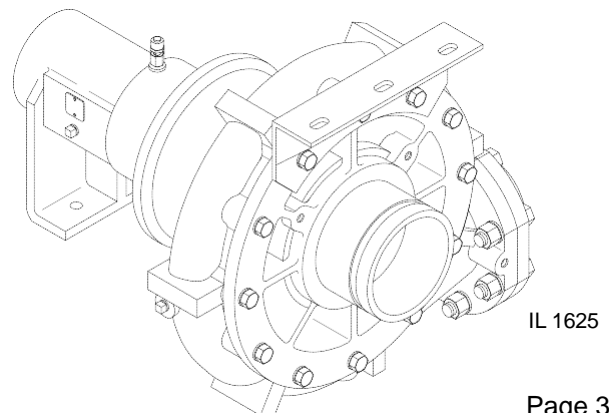

Figure 2. CZU Series Fire Pumps



# Operating Instructions

## Pumping from Water Tank

### **WARNING**

**Pressure Hazard. May result in personal injury or death.**

Prior to connection of hoses, caps or other closures with pump intake or pump discharge connections, relieve pressure by opening drains.

### **WARNING**

**Scalding Water Hazard. May result in serious burns.**

When operating the pump, be sure to open at least one discharge valve slightly to prevent the pump from overheating. If the pump runs for a few minutes completely closed, it may heat the water enough to scald someone when the valve is opened. Overheating can damage the packing, seals and other pump parts. If the apparatus builder has installed a by-pass system or other provision designed to prevent overheating, opening a discharge valve may be unnecessary.

1. Open valves in piping between water tank and pump intake, and at least one discharge valve.
2. Allow about 30 seconds for water to flow into pump.

**NOTE: Priming the pump may be necessary under some conditions because of air trapped in pump and piping.**

3. Engage pump drive and accelerate engine to obtain desired discharge pressure and capacity.

### **CAUTION**

Do not attempt to pump more water than is available from water tank. Always make sure compound gage reading stays above zero.

For pump and roll operation, engage the PTO as directed by the apparatus builder.

### *After Pumping*

### **WARNING**

**Pressure Hazard. May result in personal injury or death.**

Prior to removal of hoses, caps or other closures with pump intake or pump discharge connections, relieve pressure by opening drains.

1. Disengage pump drive.
2. If pumping anything but clean water, remove all intake and discharge caps, open all valves and open all drains. Flush entire system with clean, fresh water for several minutes to remove all traces of impurities.
3. If pump is kept full of water when not in use, make sure water is clean and non-corrosive. Make sure the pump is completely full or completely drained – never partially full.

### *NOTICE*

**Freezing water hazard. May cause damage to the pump.**

If the pump is exposed to freezing temperatures, drain all water from pump, lines and accessories.

4. Close all drains and install intake and discharge caps.
5. If truck is equipped with a priming pump, operate it until fluid is discharged from priming pump discharge pipe. Also check fluid level in priming tank, and refill if necessary.

## Pumping from Hydrant or in Relay

### WARNING

#### **Pressure Hazard. May result in personal injury or death.**

Prior to connection of hoses, caps or other closures with pump intake or pump discharge connections, relieve pressure by opening drains or bleeder valves.

### WARNING

#### **Scalding Water Hazard. May result in serious burns.**

When operating the pump, be sure to open at least one discharge valve slightly to prevent the pump from overheating. If the pump runs even for a few minutes completely closed it may heat the water enough to scald someone when the valve is opened. Overheating can damage the packing, seals and other pump parts. If the apparatus builder has installed a by-pass system or other provision designed to prevent overheating, opening a discharge valve may be unnecessary.

**NOTE: Limit inlet pressure to 150 psi (10.3 bar) if possible. The pump will operate properly with higher intake pressure but it will accelerate mechanical seal wear.**

1. Engage pump drive.
2. Open intake, hydrant and other valves as necessary to allow water to enter pump.  
**NOTE: Bleeder valves should be used while filling a hose connected to an intake with water.**
3. Open discharge valves and accelerate engine to obtain desired discharge pressure and capacity.
4. Set relief valve or other pressure governing device to desired pressure.

### NOTICE

Do not attempt to pump more water than is available from hydrant or relaying pumper. Always make sure compound gage reading stays above zero.

### *After Pumping*

### WARNING

#### **Pressure Hazard. May result in personal injury or death.**

Prior to removal of hoses, caps or other closures with pump intake or pump discharge connections, relieve pressure by opening drains or bleeder valves.

1. Disengage pump drive.
2. If pumping anything but clean water, remove all intake and discharge caps, open all valves and open all drains. Flush entire system with clean, fresh water for several minutes to remove all traces of impurities.
3. If pump is kept full of water when not in use, make sure water is clean and non-corrosive. Make sure the pump is completely full or completely drained – never partially full.

### NOTICE

#### **Freezing water hazard. May cause damage to the pump.**

If the pump is exposed to freezing temperatures, drain all water from pump, lines and accessories.

4. Close all drains and install intake and discharge caps.
5. If truck is equipped with a priming pump, operate it until fluid is discharged from priming pump discharge pipe. Also check fluid level in priming tank, and refill if necessary.

## Pumping from Draft

### **WARNING**

#### **Pressure Hazard. May result in personal injury or death.**

Prior to connection of hoses, caps or other closures with pump intake or pump discharge connections, relieve pressure by opening drains.

### **WARNING**

#### **Scalding Water Hazard. May result in serious burns.**

When operating the pump, be sure to open at least one discharge valve slightly to prevent the pump from overheating. If the pump runs even for a few minutes completely closed it may heat the water enough to scald someone when the valve is opened. Overheating can damage the packing, seals and other pump parts. If the apparatus builder has installed a by-pass system or other provision designed to prevent overheating, opening a discharge valve may be unnecessary.

#### **NOTE: To get full capacity, quick prime and maintain pump efficiency:**

- a.) Position truck as near as possible to water supply.
  - b.) Avoid humps or sharp bends in intake hose. Make sure no part of hose is higher than pump intake inlet. (Air pockets in intake hose may cause loss of prime or erratic pump action and may reduce pump capacity.)
  - c.) Make sure all intake connections are tight and discharge valves are closed.
  - d.) Immerse intake strainer at least two feet below water surface to prevent pump from drawing air (Whirlpools forming above intake strainer indicate that strainer is too close to surface of water.)
  - e.) Make sure intake strainer is far enough from bottom to prevent pumping sand, gravel or other foreign matter.
1. Prime the pump. (See separate instructions supplied with primer.)
  2. Engage pump drive.
  3. Open discharge valves and accelerate engine to obtain desired discharge pressure and capacity.
  4. Set relief valve or other pressure governing device to desired pressure.

## After Pumping

### **WARNING**

#### **Pressure Hazard. May result in personal injury or death.**

Prior to removal of hoses, caps or other closures with pump intake or pump discharge connections, relieve pressure by opening drains.

1. Disengage pump drive.
2. If pumping anything but clean water, remove all intake and discharge caps, open all valves and open all drains. Flush entire system with clean, fresh water for several minutes to remove all traces of impurities.
3. If pump is kept full of water when not in use, make sure water is clean and non-corrosive. Make sure the pump is completely full or completely drained – never partially full.

### **NOTICE**

#### **Freezing water hazard. May cause damage to the pump.**

If the pump is exposed to freezing temperatures, drain all water from pump, lines and accessories.

4. Close all drains and install intake and discharge caps.
5. If truck is equipped with a priming pump, operate it until fluid is discharged from priming pump discharge pipe. Also check fluid level in priming tank, and refill if necessary.

# Fire Hose Testing



## WARNING

### **Hose Testing Hazard. May result in serious personal injury.**

Due to a potential for catastrophic hose failure during service testing of fire hose, it is vital that safety precautions be taken to prevent exposure of anyone to this danger. Fire pumps on fire department apparatus are not designed for and should not be used for service testing of fire hoses. Hose testing machines should be used for service testing of fire hoses.

NFPA 1962 *Standard for the Inspection, Care, and use of Fire Hose, Couplings, and Nozzles and the Service Testing of Fire Hose* provides requirements and testing procedures for service-testing fire hose at least annually. NFPA 1962 includes procedures for service testing with either a hose testing machine or with a pump on a fire department fire apparatus.



## WARNING

### **Pressure Hazard. May result in serious personal injury.**

If a fire pump on a fire department apparatus is used for service testing of fire hoses, the procedures in NFPA 1962 **MUST be followed** including the use of a fire department gate valve with a ¼-inch (6 mm) hole drilled through the gate installed between the fire apparatus discharge outlet and the hose test layout to prevent a volume surge from the pump in the event a hose bursts during testing.

During fire hose testing with a fire pump on a fire department fire apparatus, the fire pump is required to be operated at high discharge pressure with little or no flow out of the apparatus.



## WARNING

### **Scalding Water Hazard. May result in serious burns.**

If a fire pump on a fire department apparatus is used for service testing of fire hoses, pump discharge water must be circulated through a by-pass system or discharged through a slightly open discharge valve, or some other provision must be used to prevent overheating. If the pump runs for a few minutes without adequate flow through the pump, water may be heated enough to scald someone when a valve is opened.

## NOTICE

If a fire pump on a fire department apparatus is used for service testing of fire hoses, operating the pump at high discharge pressure with little or no flow may result in severe damage to the pump.



# Maintenance

## Corrosion Protection

### Optional Intake Screens

Once per month check to make sure the intake screens are not clogged or damaged. Also check for corrosion, and replace screens if damage is severe. For the screen to adequately control corrosion, there must be a strong electrical contact between the screen and the fitting. Remove any corrosion, debris or paint from the counter bore that will insulate the screen from the intake fitting. If the screen does not fit tightly, adjust the gap of the slot on the outside diameter of the screen to ensure a tight fit.

**NOTE:** These screens are die-cast which results in a slight taper from one side to the other. Install the screen with the thinner cross-section facing out to minimize flow restriction.

Figure 3. Intake Screens

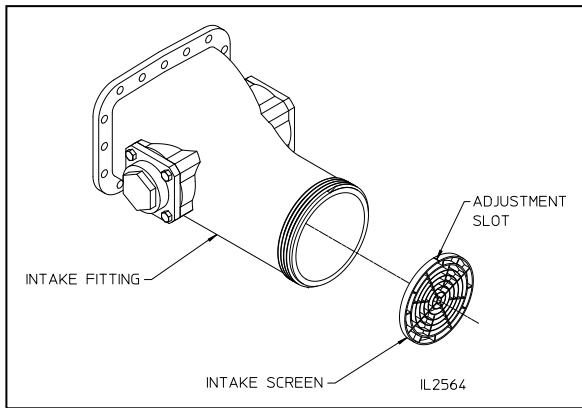

### Optional Anodes

Twice per year, remove the anodes and check for erosion of the replaceable elements. Replace the elements if more than half of either of the elements has eroded. Anodes are normally mounted on the pump intake piping, but they may also be installed in the discharge piping if no intake mounting locations were available. Physical mounting of the anode may be via an NPT tap or bolt-on flange as described below.

**NOTE:** The replaceable elements must make contact with water to be effective. Do not paint or use any other coating on the replacement elements.

### Bolt-on Anodes

Unscrew the (4) hex head screws from the pump. If elements require replacement, unscrew the hex head cap screw.

**NOTE:** There is no need to remove the threaded anode adapter from the anode flange for element replacement. The screw was installed using thread sealant so higher force than normal may be necessary to remove.

Replace one or both elements as necessary. Install the hex head screw using Loctite 242 (blue) on the screw threads. Mount the anode assembly back on the fitting.

Figure 4. Bolt-on Anodes

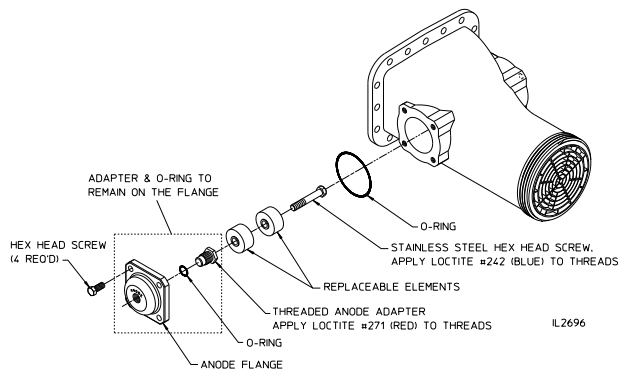

### Threaded Anodes

**NOTE:** The 2-1/2 in. hex is threaded into a bushing that should remain on the pump. Be sure to restrain the bushing when removing the 2-1/2 in. hex.

Unscrew the 2-1/2 in. hex from the pump. If the elements require replacement, unscrew the hex head cap screw.

**NOTE:** The screw was installed using thread sealant so higher force than normal may be necessary to remove.

Replace one or both elements as necessary. Install the hex head screw using Loctite 242 (blue) on the screw threads. Remove any paint or corrosion from the face around the NPT tap on the pump. Apply thread sealant to the threads and screw the 2-1/2 in. hex into the pipe tap until tight.

Figure 5. Threaded Anodes

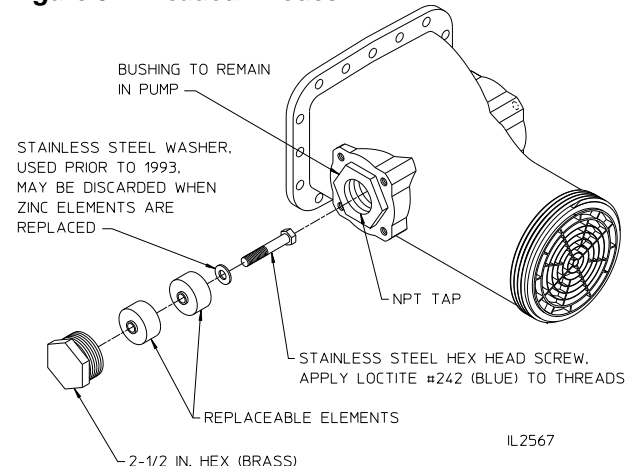

## Lubrication

A fluid splash system, within the bearing housing, lubricates the bearings. Check fluid level monthly by removing the square head pipe plug on side of bearing housing marked OIL LEVEL. The oil should be level with the bottom of the hole.

### NOTICE

If fluid level is low, locate the source of the leak and repair. If the fluid level is high, loosen the drain plug until the fluid drops to the proper level. If excessive water drains out, change the fluid and determine the source of the water leakage and repair.

### NOTICE

**Fluid temperature hazard.  
May cause premature seal wear and damage.**

Fluid temperature should not exceed 250 F (121 C) for an extended period of time in order to prevent seal wear and damage.

To add fluid, remove filler plug or breather on the bearing housing and pour fluid through the opening. Fill to bottom thread of oil level hole. *Do not Overfill.* Use non-detergent SAE 30 oil.

Drain bearing housing by removing magnetic drain plug from bottom and refill with new lubricant after each accumulated 100 hours of pump operation, or at least every spring and fall. (Under severe service conditions, where pump has been used continuously at high output, change fluid more frequently.) The capacity is approximately 1/4 quart. Be sure to clean drain plug and breather.

**Figure 6. CZ Pump**

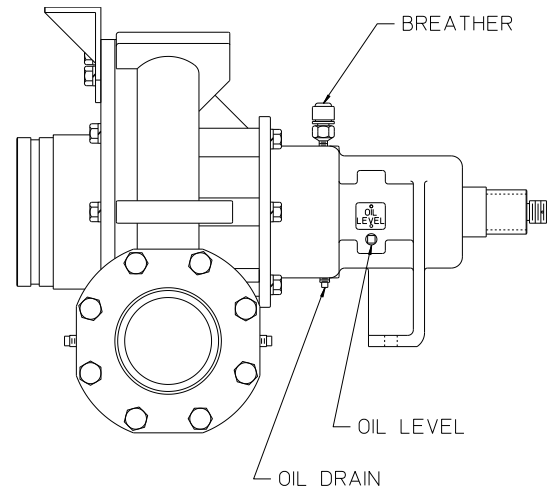

FROM DPL81700

## Mechanical Seal

A mechanical shaft seal is used and no adjustment is required. When the pump operates, the water being pumped cools and lubricates the shaft seal to prevent it from overheating.

### NOTICE

Prolonged dry pump operation or operating a dry pump at high speeds will reduce the life of the mechanical seal.

If the mechanical seal leaks, replace the entire seal.

The same drain (weep hole) is used to vent the mechanical seal on the pump shaft and the oil seal for the bearing housing. Inspect for water (mechanical seal) or oil (oil seal) leaks.

## Overheat Protection Manager

Check the electrical circuit by pressing the test button located on the panel plate every 100 hours of pump operation or every six months, whichever comes first.

If the light does not flash, the light bulb or flasher may need replacement (provided all wire connections are solid).

**Figure 7. Cross-Sectional View, CZ and CZU**

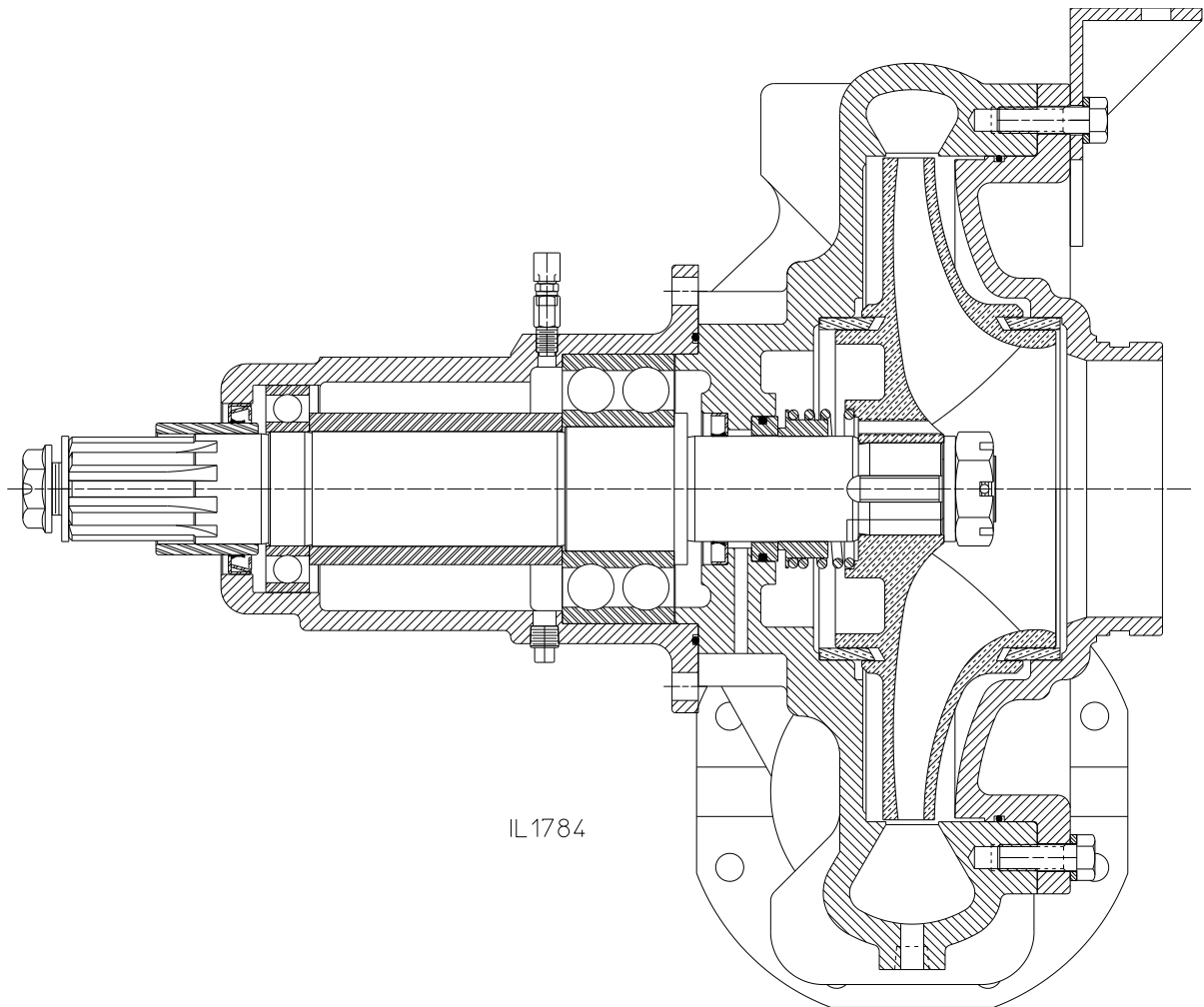

IL 1784