

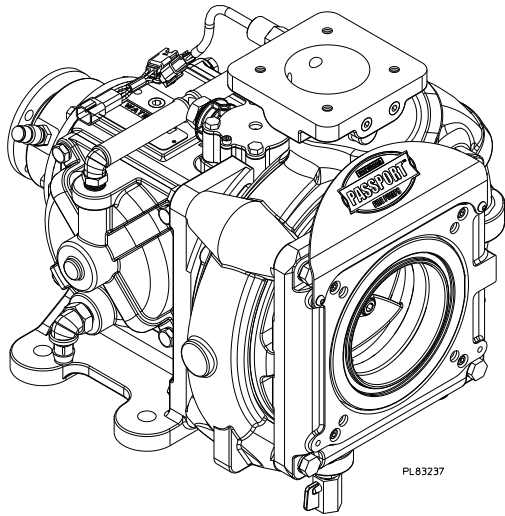

S200-P Series Centrifugal Fire Pumps Operation and Maintenance Instructions

Table of Contents



Read through the safety information and operating instructions carefully before using your S200-P Series Fire Pump.

Safety Information	2, 3
Introduction	4
General Description	4
Operational Limits	4
Components	5
Operating Instructions	
Pumping from Hydrant or in Relay	6
Pumping from Water Tank	7
Pumping from Draft	8
Fire Hose Testing.....	9
Maintenance	10
Mechanical Seal.....	10
Lubrication	10
Testing	10

NOTE: Instructions subject to change without notice

Safety Information



Read through the safety information and operating instructions before using your Fire Pump.

WARNING

Death or serious personal injury might occur if proper operating procedures are not followed. The pump operator, as well as individuals connecting supply or discharge hoses to the apparatus must be familiar with these pump operating instructions as well as other operating instructions and manuals for the apparatus, water hydraulics and component limitation.

WARNING

Pressure Hazard. May result in personal injury.

Prior to connection or removal of hoses, caps or other closures with pump intake or pump discharge connections, relieve pressure by opening drains or bleeder valves. Bleeder valves should also be used while filling a hose connected to an intake with water.

WARNING

Scalding Water Hazard. May result in serious burns.

When operating the pump, be sure to open at least one discharge valve slightly to prevent the pump from overheating. If the pump runs for a few minutes completely closed, it may heat the water enough to scald someone when the valve is opened. Overheating can damage the packing, seals and other pump parts. If the apparatus builder has installed a by-pass system or other provision designed to prevent overheating, opening a discharge valve may be unnecessary.

WARNING

Unexpected Truck Movement. May result in serious personal injury or death.

Failure to properly shift transmission in accordance to the transmission operation instructions may result in unexpected truck movement which may result in serious personal injury or death.

Intended Uses

The S200-P series pump is a centrifugal water pump that is intended to be used for firefighting operations. It is an incomplete machine that is intended to be incorporated into completed apparatus such as firefighting vehicles.

The S200-P series pump is not intended to pump fuels, combustible liquids, oil, solids or slurries.

Operator Training

It is intended that the S200-P series pumps will be operated by personnel trained in firefighting tactics and the use of centrifugal firefighting water pumps.

Noise

While the pump is in operation, use appropriate ear protection to guard against the noise generated by the pump.

The maximum sound pressure level is 85dB as measured at factory conditions.

Pump Operation

- Make sure all rotating components are adequately guarded to prevent accidental contact.
- Do not place any object or hand into the intake of the pump while in operation.
- Do not disconnect the discharge hoses while they are pressurized.
- Do not unfasten any component while the pump is in operation.
- Use suitable hoists or lifting devices when removing or installing the pump.

Safety Information



Read through the safety information and operating instructions before using your Fire Pump.



WARNING

Hose Testing Hazard. May result in serious personal injury.

Due to a potential for catastrophic hose failure during service testing of fire hose, it is vital that safety precautions be taken to prevent exposure of anyone to this danger. Fire pumps on fire department apparatus are not designed for and should not be used for service testing of fire hoses. Hose testing machines should be used for service testing of fire hoses.



WARNING

Pressure Hazard. May result in serious personal injury.

If a fire pump on a fire department apparatus is used for service testing of fire hoses, the procedures in NFPA 1962 **MUST be followed** including the use of a fire department gate valve with a ¼-inch (6 mm) hole drilled through the gate installed between the fire apparatus discharge outlet and the hose test layout to prevent a volume surge from the pump in the event a hose bursts during testing.



WARNING

Scalding Water Hazard. May result in serious burns.

If a fire pump on a fire department apparatus is used for service testing of fire hoses, pump discharge water must be circulated through a by-pass system or discharged through a slightly open discharge valve, or some other provision must be used to prevent overheating. If the pump runs for a few minutes without adequate flow through the pump, water may be heated enough to scald someone when a valve is opened.

Introduction

This instruction contains the information needed for operation and maintenance of the S200-P Series fire pump.

General Description

The S200-P series are pedestal mounted fire pumps designed to meet the EN 1028 Standard:

2000 L/min @ 10 bar	2000 L/min @ 15 bar
3000 L/min @ 10 bar	3000 L/min @ 15 bar

Before operating the S200-P pump, read the following instructions carefully.

Operational Limits

Maximum Angle of Inclination

The maximum angle of inclination for pump operation is 15 degrees.

Maximum Pump Speed

The pump has a maximum operating speed that is listed in Table 1. **Do not exceed this speed.**

Priming Speed

When priming the pump, the optimal pump speed is 2000 rpm and the recommended maximum priming speed is 2200 rpm.

NOTE: Engaging the primer at speeds higher than 2200 rpm for an extended period of time will not improve primer performance and will negatively affect service for life.

S200-P Series

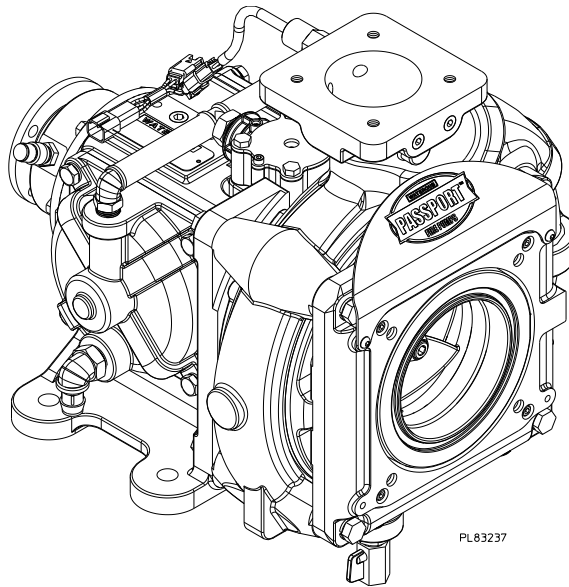

Table 1: S200-P Specifications

EN Designation (EN 1028-1)		FPN 10-2000	FPN 15-2000	FPN 10-3000	FPN 15-3000
Nominal Flow Rate Q _N	l/min	2000	2000	3000	3000
Nominal Rated Pressure P _N	bar	10	15	10	15
Nominal Speed N _N	min ⁻¹	2970	3610	3180	3780
Maximum Speed N ₀	min ⁻¹	3600	4050	3600	4050
Limit Pressure P _{alim}	bar	17	20	17	20
Priming Speed N _s	min ⁻¹	2000	2000	2000	2000
Priming Time for 6m Suction Height (EN 1846-3)	sec	≤40 (1) DN100 Hose	≤40 (1) DN100 Hose	≤40 (2) DN100 Hoses or (1) DN150 Hose	≤40 (2) DN100 Hoses or (1) DN150 Hose

Components

Body Assembly

The body is constructed of corrosion-resistant bronze and other composite components.

Impeller

The impeller is constructed of bronze.

Impeller Shaft Assembly

The impeller shaft assembly consists of an impeller mounted on a stainless steel shaft with self-lubricated sealed bearings.

Pedestal (Primer Housing)

The pedestal is constructed of anodized aluminum and supports the piston primers and main bearings. Contains no oil so no maintenance is required.

Mechanical Seal

The mechanical seal consists of a flat, highly polished (lapped), self-adjusting (spring-fed) carbon ring that is sealed in the pump body. The carbon ring presses against a highly-polished rotating ring that is sealed to and rotates with the impeller. Mechanical seal is retained in an easily removable seal housing.

Pump Drain

One 3/4" drain with a 1/4 turn manual valve is provided on the volute.

Automatic Piston Primer

The pump is equipped with two automatic piston primers. For best performance, operate primers at 2000 rpm (pump speed). The primers will still perform at lower speeds, but priming time will increase. Operating the primers at speeds greater than 2200 rpm will not significantly improve priming time and can negatively affect service life of the priming system. Primer may be equipped with a manual shut-off.

Thermal Relief Valve

The thermal relief valve opens as the temperature of the water inside the pump reaches 490 C. The valve opens and diverts water to one of the following locations:

To the holding tank, vehicle tank or to atmosphere (ground).

Tachometer Connection

A magnetic pick-up feeds the pump shaft revolutions to a tachometer which displays the pump impeller speed in revolutions per minute (four pulses per revolution).

Lubrication

No lubrication is required as the bearings are sealed, pedestal and primers are oil-free and the mechanical seal is maintenance free.

Components

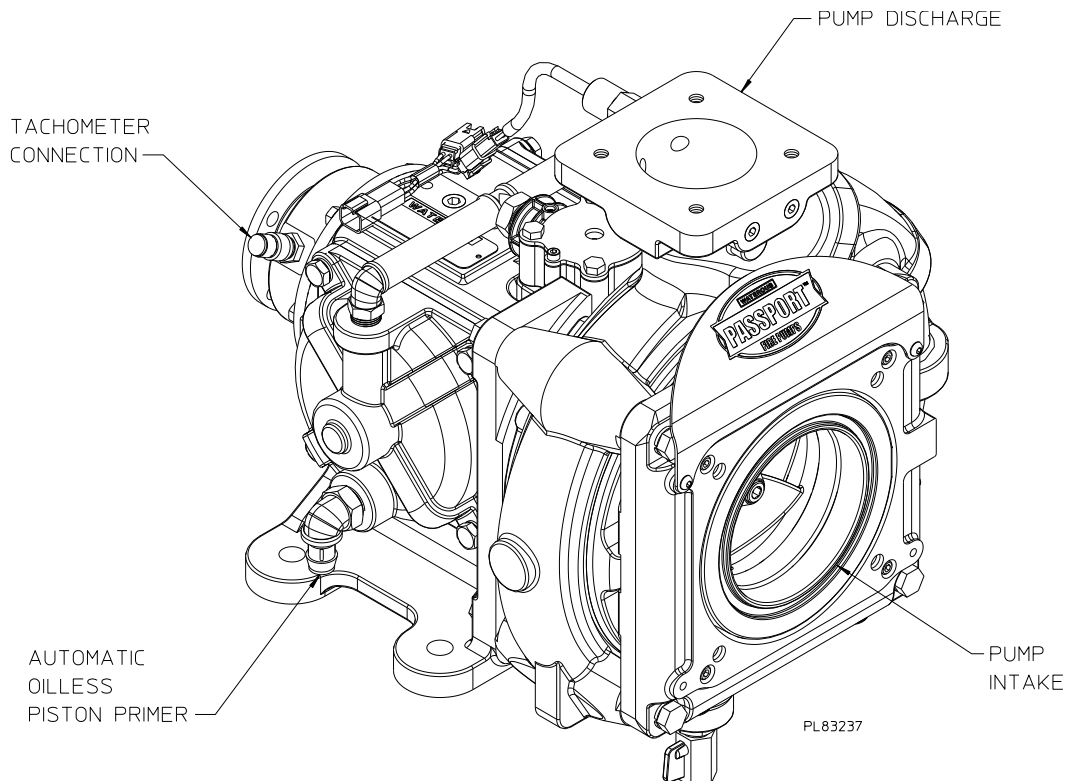

Operating Instructions

Pumping from Hydrant or in Relay

WARNING

Pressure Hazard. May result in personal injury.

Prior to connection or removal of hoses, caps or other closures with pump intake or pump discharge connections, relieve pressure by opening drains or bleeder valves. Bleeder valves should also be used while filling a hose connected to an intake with water.

WARNING

Scalding Water Hazard. May result in serious burns.

When operating the pump, be sure to open at least one discharge valve slightly to prevent the pump from overheating. If the pump runs for a few minutes completely closed, it may heat the water enough to scald someone when the valve is opened. Overheating can damage the packing, seals and other pump parts. If the apparatus builder has installed a bypass system or other provision designed to prevent overheating, opening a discharge valve may be unnecessary.

1. Open intake, hydrant and other valves as necessary to allow water to enter the pump.
2. Allow about 30 seconds for water to flow into pump.
3. Engage pump drive in accordance with the vehicle operation instructions and accelerate engine to obtain desired discharge pressure and capacity.

NOTICE

This pump has a mechanical seal, limit intake pressure to 75 psi (5 bar) if possible. Although the pump will operate properly with higher intake pressure, such operation will greatly accelerate mechanical seal wear.

NOTE: The S200-P pump has an automatic priming system that will engage or disengage when the discharge pressure rises above or falls below a predetermined setting.

4. Open discharge valves and accelerate engine to obtain desired discharge pressure and capacity.

NOTICE

Do not attempt to pump more water than is available from the hydrant or relaying pumper. Always make sure the intake pressure compound-gage reading stays above zero. Some fire departments operate at a minimum intake pressure of 15 psi (1 bar) when pumping from hydrant or in relay to prevent a "soft" intake hose from collapsing.

5. Set low pressure relief valve or other governing device to desired pressure (relief valve or governing device not supplied by Waterous).

After Pumping

1. If pumping anything but clean water, remove all intake and discharge caps, open all valves and open all drains. Flush entire system with clean, fresh water for several minutes to remove all traces of impurities.
2. Cycle the piston primers. Operate them until all the fluid is discharged from the piston primer discharge pipes.

NOTICE

Freezing water hazard. May cause damage to the pump.

If the pump is exposed to freezing temperatures, drain all water from pump, lines and accessories.

3. If pump is kept full of water when not in use, make sure water is clean and non-corrosive. Make sure the pump is completely full or completely drained (never partially full).
4. Disengage pump drive in accordance with the vehicle operation instructions.
5. Close all drains and install intake and discharge caps.

Pumping from Water Tank

WARNING

Pressure Hazard. May result in personal injury.

Prior to connection or removal of hoses, caps or other closures with pump intake or pump discharge connections, relieve pressure by opening drains or bleeder valves. Bleeder valves should also be used while filling a hose connected to an intake with water.

WARNING

Scalding Water Hazard. May result in serious burns.

When operating the pump, be sure to open at least one discharge valve slightly to prevent the pump from overheating. If the pump runs for a few minutes completely closed, it may heat the water enough to scald someone when the valve is opened. Overheating can damage the packing, seals and other pump parts. If the apparatus builder has installed a bypass system or other provision designed to prevent overheating, opening a discharge valve may be unnecessary.

1. Open valve(s) in piping between water tank and pump intake and at least one discharge valve.
2. Allow about 30 seconds for water to flow into pump.

NOTE: The S200-P pump has an automatic priming system that will engage or disengage when the discharge pressure rises above or falls below a predetermined setting.

3. Engage pump drive in accordance with the vehicle operation instructions and accelerate engine to obtain desired discharge pressure and capacity.

NOTICE

Do not attempt to pump more water than is available from the water tank. Always make sure the intake pressure compound gage reading stays above zero.

4. Open discharge valves and accelerate engine to obtain desired discharge pressure and capacity.
5. Set low pressure relief valve or other governing device to desired pressure (relief valve or governing device not supplied by Waterous).

After Pumping

1. If pumping anything but clean water, remove all intake and discharge caps, open all valves and open all drains. Flush entire system with clean, fresh water for several minutes to remove all traces of impurities.
2. Cycle the piston primers. Operate them until all the fluid is discharged from the piston primer discharge pipes.

NOTICE

Freezing water hazard. May cause damage to the pump.

If the pump is exposed to freezing temperatures, drain all water from pump, lines and accessories.

3. If pump is kept full of water when not in use, make sure water is clean and non-corrosive. Make sure the pump is completely full or completely drained (never partially full).
4. Disengage pump drive in accordance with the vehicle operation instructions.
5. Close all drains and install intake and discharge caps.

Pumping from Draft

WARNING

Pressure Hazard. May result in personal injury.

Prior to connection or removal of hoses, caps or other closures with pump intake or pump discharge connections, relieve pressure by opening drains or bleeder valves. Bleeder valves should also be used while filling a hose connected to an intake with water.

WARNING

Scalding Water Hazard. May result in serious burns.

When operating the pump, be sure to open at least one discharge valve slightly to prevent the pump from overheating. If the pump runs for a few minutes completely closed, it may heat the water enough to scald someone when the valve is opened. Overheating can damage the packing, seals and other pump parts. If the apparatus builder has installed a bypass system or other provision designed to prevent overheating, opening a discharge valve may be unnecessary.

NOTE: To get full capacity, quick prime and maintain pump efficiency:

- a. Position vehicle as near as possible to water supply.
- b. Avoid humps and sharp bends in intake hose. Make sure no part of hose is higher than pump inlet. (Air pockets in intake hose may cause loss of prime or erratic pump action, and may reduce pump capacity.)
- c. Make sure all intake connections are tight and discharge valves are closed.
- d. Immerse intake strainer at least two feet (.5 M) below water surface to prevent pump from drawing air. (Whirlpools forming above intake strainer indicate that strainer is too close to surface of water.)
- e. Make sure intake strainer is far enough from bottom to prevent sand, gravel and other foreign matter from being drawn into the pump.
6. Open suction valve (if equipped) as necessary to allow water to enter the pump.
7. Engage pump drive in accordance to with the vehicle operation instructions and accelerate engine to obtain desired discharge pressure and capacity.

NOTE: The S200-P pump has an automatic priming system that will engage or disengage when the discharge pressure rises above or falls below a predetermined setting.

8. Open discharge valves, and accelerate engine to obtain desired discharge pressure and capacity.
9. Set low pressure relief valve or other governing device to desired pressure (relief valve or governing device not supplied by Waterous).

After Pumping

1. If pumping anything but clean water, remove all intake and discharge caps, open all valves and open all drains. Flush entire system with clean, fresh water for several minutes to remove all traces of impurities.
2. Cycle the piston primers. Operate them until all the fluid is discharged from the piston primer discharge pipes.

NOTICE

Freezing water hazard. May cause damage to the pump.

If the pump is exposed to freezing temperatures, drain all water from pump, lines and accessories.

3. If pump is kept full of water when not in use, make sure water is clean and non-corrosive. Make sure the pump is completely full or completely drained (never partially full).
4. Disengage pump drive in accordance with the vehicle operation instructions.
5. Close all drains and install intake and discharge caps.

Fire Hose Testing



WARNING

Hose Testing Hazard. May result in serious personal injury.

Due to a potential for catastrophic hose failure during service testing of fire hose, it is vital that safety precautions be taken to prevent exposure of anyone to this danger. Fire pumps on fire department apparatus are not designed for and should not be used for service testing of fire hoses. Hose testing machines should be used for service testing of fire hoses.

NFPA 1962 *Standard for the Inspection, Care, and use of Fire Hose, Couplings, and Nozzles and the Service Testing of Fire Hose* provides requirements and testing procedures for service-testing fire hose at least annually. NFPA 1962 includes procedures for service testing with either a hose testing machine or with a pump on a fire department fire apparatus.



WARNING

Pressure Hazard. May result in serious personal injury.

If a fire pump on a fire department apparatus is used for service testing of fire hoses, the procedures in NFPA 1962 **MUST be followed** including the use of a fire department gate valve with a ¼-inch (6 mm) hole drilled through the gate installed between the fire apparatus discharge outlet and the hose test layout to prevent a volume surge from the pump in the event a hose bursts during testing.

During fire hose testing with a fire pump on a fire department fire apparatus, the fire pump is required to be operated at high discharge pressure with little or no flow out of the apparatus.



WARNING

Scalding Water Hazard. May result in serious burns.

If a fire pump on a fire department apparatus is used for service testing of fire hoses, pump discharge water must be circulated through a by-pass system or discharged through a slightly open discharge valve, or some other provision must be used to prevent overheating. If the pump runs for a few minutes without adequate flow through the pump, water may be heated enough to scald someone when a valve is opened.

CAUTION

If a fire pump on a fire department apparatus is used for service testing of fire hoses, operating the pump at high discharge pressure with little or no flow may result in severe damage to the pump.

Maintenance

NOTICE

All pump maintenance can be performed using standard tools.

Mechanical Seal

NOTICE

The pump shaft is sealed with a mechanical seal and no adjustment is required. When the pump is in operation, the water being pumped lubricates and cools the seal. If the seal leaks, replace the entire seal.

NOTICE

Prolonged dry pump operation or operating a dry pump at high speeds will reduce the life of the mechanical seal.

Lubrication

NOTICE

No lubrication is needed. The bearings are sealed, the primer and pedestal are oil-free and the mechanical seal is lubricated by water..

Testing

NOTICE

An annual test should be performed to check pump performance. This will reveal the condition of the internal components and if any repairs are required.