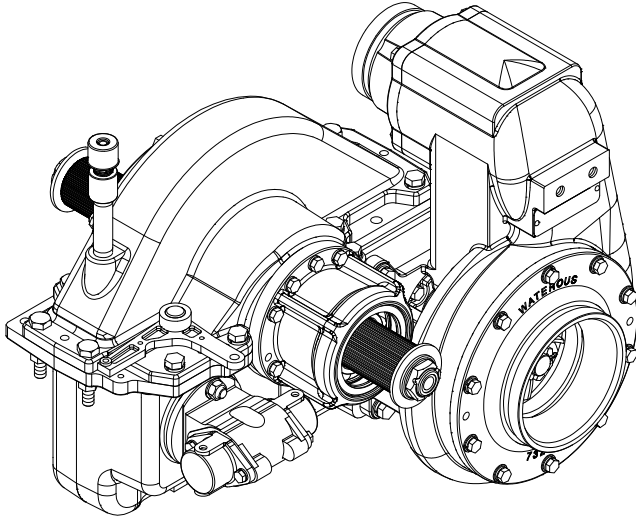

Table of Contents



Safety Information	2
Introduction	3
General Description	3
Components	3
Pump Models	4
Operating Instructions	
Pumping from Water Tank	5
Pumping from in Relay	6
Pumping from Draft	7
Mechanical Seal	8
Lubrication	9



Read through the operation instructions carefully before using your Waterous RF-600 Series Pump

NOTE: Instructions subject to change without notice

Safety Information



Read through the safety information and operating instructions carefully before using your Waterous Pump.

WARNING

Death or serious personal injury might occur if proper operating procedures are not followed. The pump operator, as well as individuals connecting supply or discharge hoses to the apparatus must be familiar with these pump operating instructions as well as other operating instructions and manuals for the apparatus, water hydraulics and component limitation.

WARNING

Unexpected Truck Movement. May result in serious personal injury or death.

Failure to properly shift transmission in accordance to the transmission operating instructions may result in unexpected truck movement which may result in serious personal injury or death.

WARNING

Pressure Hazard. May result in personal injury.

Prior to connection or removal of hoses, caps or other closures with pump intake or pump discharge connections, relieve pressure by opening drains or bleeder valves. Bleeder valves should also be used while filling a hose connected to an intake with fluids.

WARNING

Scalding Water Hazard. May result in serious burns.

When operating the pump, be sure to open at least one discharge valve slightly to prevent the pump from overheating. If the pump runs for a few minutes completely closed, it may heat the water enough to scald someone when the valve is opened. Overheating can damage the packing, seals and other pump parts. If the apparatus builder has installed a by-pass system or other provision designed to prevent overheating, opening a discharge valve may be unnecessary.

Introduction

This instruction contains the information needed for operation and maintenance of RF-600 Series pumps.

General Description

The RF-600 series pumps are single stage centrifugal end suction pumps providing capacities up to 600 GPM (2200 L/min). RF-600 models are midship mounted with a Victaulic® discharge fitting.

Components

Body Assembly

This assembly includes a single stripping edge volute body, intake adapter and related parts. The body and adapters are anodized aluminum.

Impeller Shaft Assembly

This assembly consists of a aluminum, flame-plated impeller mounted on a stainless steel shaft, wear rings, mechanical seal and related parts. The impeller is balanced and the impeller shaft is supported by ball bearings.

Mechanical Seal

The mechanical seal consists of a flat, highly polished (lapped), spring-fed carbon ring that is sealed to and rotates with the impeller shaft. It presses against a highly polished (lapped) silicon carbide mating ring that is sealed in the volute body. This seals the shaft and prevents air from entering and water from leaving. A mechanical seal does not leak or drip water, even when pumping.

Pump Models

RF-600 Series

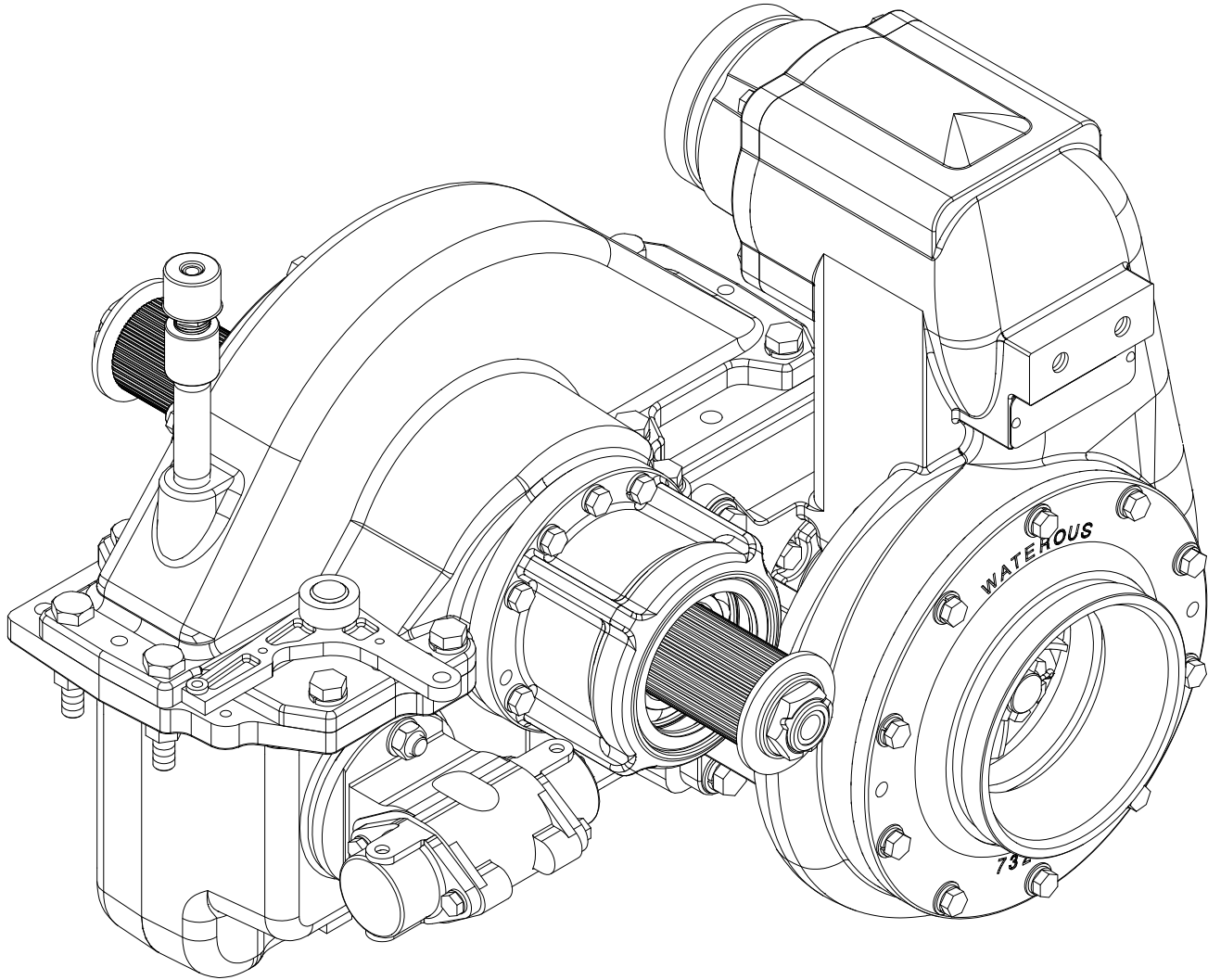

Operating Instructions

Pumping from Tank

WARNING

Pressure Hazard. May result in personal injury or death.

Prior to connection of hoses, caps or other closures with pump intake or pump discharge connections, relieve pressure by opening drains.

WARNING

Scalding Water Hazard. May result in serious burns.

When operating the pump, be sure to open at least one discharge valve slightly to prevent the pump from overheating. If the pump runs for a few minutes completely closed, it may heat the water enough to scald someone when the valve is opened. Overheating can damage the packing, seals and other pump parts. If the apparatus builder has installed a by-pass system or other provision designed to prevent overheating, opening a discharge valve may be unnecessary.

1. Open valve(s) in piping between tank and pump intake and at least one discharge valve.
2. Allow about 30 seconds for water or fuel to flow into pump.

WARNING

Unexpected Truck Movement. May result in personal injury or death.

Failure to properly shift transmission in accordance with the transmission operating instructions may result in unexpected truck movement which may result in serious personal injury or death.

3. **WRX Transmission:** Engage pump in accordance with transmission instructions.

CAUTION

Do not attempt to pump more water or fuel than is available from the tank. Always make sure the intake pressure compound gage reading stays above zero.

4. Set relief valves or other pressure governing device to desired pressure.

After Pumping

WARNING

Pressure Hazard. May result in personal injury or death.

Prior to removal of hoses, caps or other closures with pump intake or pump discharge connections, relieve pressure by opening drains.

1. Disengage pump drive. If equipped with a WRX transmission disengage pump drive in accordance with the transmission instructions.
2. If pumping anything but clean water, remove all intake and discharge caps, open all valves and open all drains. Flush entire system with clean, fresh water for several minutes to remove all traces of impurities.
3. Close all drains and install intake and discharge caps.

Pumping in Relay

WARNING

Pressure Hazard. May result in personal injury or death.

Prior to connection of hoses, caps or other closures with pump intake or pump discharge connections, relieve pressure by opening drains or bleeder valves.

WARNING

Scalding Water Hazard. May result in serious burns.

When operating the pump, be sure to open at least one discharge valve slightly to prevent the pump from overheating. If the pump runs even for a few minutes completely closed it may heat the water enough to scald someone when the valve is opened. Overheating can damage the packing, seals and other pump parts. If the apparatus builder has installed a by-pass system or other provision designed to prevent overheating, opening a discharge valve may be unnecessary.

WARNING

Unexpected Truck Movement. May result in personal injury or death.

Failure to properly shift transmission in accordance with the transmission operating instructions may result in unexpected truck movement which may result in serious personal injury or death.

4. **WRX Transmission:** Engage pump in accordance with transmission instructions.
5. Open intake and other valves as necessary to allow water or fuel to enter the pump.

NOTE: Bleeder valves should be used while filling a hose connected to an intake with water or fuel.

CAUTION

Limit intake pressure to 75 psi (5.2 bar) if possible. Although the pump will operate properly with higher intake pressure, such operation will greatly accelerate mechanical seal wear.

6. Open discharge valves and accelerate engine to obtain desired discharge pressure and capacity.
7. Set relief valves or other pressure governing device to desired pressure.

CAUTION

Do not attempt to pump more water or fuel than is available from the hydrant or relaying pumper. Always make sure the intake pressure compound gage reading stays above zero.

NOTE: Some fire departments operate at a minimum intake pressure of 10 psi (.7 bar) when pumping in relay to prevent a "soft" intake hose from collapsing.

After Pumping

WARNING

Pressure Hazard. May result in personal injury or death.

Prior to removal of hoses, caps or other closures with pump intake or pump discharge connections, relieve pressure by opening drains or bleeder valves.

1. Disengage pump drive. If equipped with a WRX transmission disengage pump drive in accordance with the transmission instructions.
2. If pumping anything but clean water, remove all intake and discharge caps, open all valves and open all drains. Flush entire system with clean, fresh water for several minutes to remove all traces of impurities.
3. If pump is kept full of water when not in use, make sure water is clean and non-corrosive. Make sure the pump is completely full or completely drained (never partially full).

CAUTION

4. Close all drains and install intake and discharge caps.
5. If truck is equipped with a priming pump, operate it until fluid is discharged from priming pump discharge pipe. If equipped with a priming tank, check fluid level and refill if necessary.

Pumping from Draft

WARNING

Pressure Hazard. May result in personal injury or death.

Prior to connection of hoses, caps or other closures with pump intake or pump discharge connections, relieve pressure by opening drains.

WARNING

Scalding Water Hazard. May result in serious burns.

When operating the pump, be sure to open at least one discharge valve slightly to prevent the pump from overheating. If the pump runs even for a few minutes completely closed it may heat the water enough to scald someone when the valve is opened. Overheating can damage the packing, seals and other pump parts. If the apparatus builder has installed a by-pass system or other provision designed to prevent overheating, opening a discharge valve may be unnecessary.

WARNING

Unexpected Truck Movement. May result in personal injury or death.

Failure to properly shift transmission in accordance with the transmission operating instructions may result in unexpected truck movement which may result in serious personal injury or death.

NOTE: To get full capacity, quick prime and maintain pump efficiency:

- a) Position vehicle as near as possible to water or fuel supply.
- b) Avoid humps and sharp bends in intake hose. Make sure no part of hose is higher than pump inlet. (Air pockets in intake hose may cause loss of prime or erratic pump action, and may reduce pump capacity.)
- c) Make sure all intake connections are tight and discharge valves are closed.

- d) Immerse intake strainer at least two feet below water or fuel surface to prevent pump from drawing air. (Whirlpools forming above intake strainer indicate that strainer is too close to surface of water.)
 - e) Make sure intake strainer is far enough from bottom to prevent sand, gravel and other foreign matter from being drawn into the pump.
1. **RF-600:** Engage pump in accordance with transmission instructions.
 2. Set relief valves or other pressure governing device to desired pressure.

After Pumping

WARNING

Pressure Hazard. May result in personal injury or death.

Prior to removal of hoses, caps or other closures with pump intake or pump discharge connections, relieve pressure by opening drains.

1. Disengage pump drive. If equipped with a WRX transmission disengage pump drive in accordance with the transmission instructions.
2. If pumping anything but clean water, remove all intake and discharge caps, open all valves and open all drains. Flush entire system with clean, fresh water for several minutes to remove all traces of impurities.

CAUTION

Freezing water hazard. May cause damage to the pump.

If the pump is exposed to freezing temperatures, drain all water from pump, lines and accessories.

3. Close all drains and install intake and discharge caps.

Mechanical Seal

A mechanical shaft seal is used and no adjustment is required. When the pump operates, the water being pumped cools and lubricates the shaft seal to prevent it from overheating.

CAUTION

Prolonged dry pump operation or operating a dry pump at high speeds will reduce the life of the mechanical seal.

If the mechanical seal leaks, replace the entire seal.

The RF-600 is equipped with drain notches on the pump body/transmission mounting flange or bearing housing. If any water or fuel seeps through the mechanical seal in the pump or oil seeps through the oil seal in the transmission or bearing housing, a V-ring on the impeller shaft directs the oil or water into the drain notches. This prevents water from entering into the oil in the transmission/bearing housing or oil from entering into the water supply of the pump.

Lubrication

1. Check the lubrication fluid level monthly by checking the sight plug or by removing the oil level plug. The fluid should be level with the bottom of the oil level hole.

CAUTION

Low or excessive lubrication fluid may cause damage.

If lubricant fluid level is low, locate source of leak and repair. If level is high, loosen oil level plug and drain until proper level is reached. If any water drains out, change lubrication fluid and determine source of water leakage and repair.

2. Change lubrication fluid and clean breather once a year or after each 100 hours of operation, whichever comes first. Lubrication fluid may be added through the oil level hole or by removing the breather and adding fluid through the opening. Any type of automatic transmission fluid (ATF) may be used.

3. Quantities of lubrication fluid if system is completely drained and refilled:

RF-600 Series Models:

Approximately 8 quarts of ATF.