

Discharge Relief Valve

Operation and Maintenance

| Form No. | Section | Issue Date | Rev. Date |
|----------|---------|------------|-----------|
| F-1031 | 2302.6 | 11/95 | 2/19/18 |

Table of Contents

| | |
|---|---|
| Safety Information | 2 |
| General Description | 3 |
| Operating Instructions | 7 |
| After Pumping | 7 |
| Maintenance Instructions | 8 |
| Service Checks (Indicator Lights) | 8 |

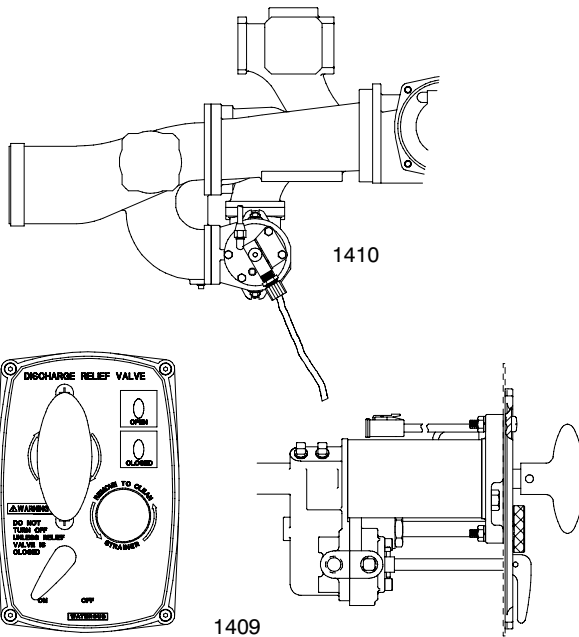

Illustrations

Figures:

1. Pilot Valve 3
2. Relief Valve 3
3. Discharge Relief Valve Operation - OFF Position 4
4. Discharge Relief Valve Operation - ON Position, Main Valve Closed 5
5. Discharge Relief Valve Operation - ON Position, Main Valve Closed 6



Read through the safety information and operating instructions carefully before using your Waterous Fire Pump.



Visit us at www.waterousco.com

Safety Information



Read through the safety information and operating instructions carefully before using your Waterous Discharge Relief Valve.

WARNING

Death or serious personal injury might occur if proper operating procedures are not followed. The pump operator, as well as individuals connecting supply or discharge hoses to the apparatus must be familiar with these pump operating instructions as well as other operating instructions and manuals for the apparatus, water hydraulics and component limitation.

WARNING

Pressure Hazard. May result in personal injury.

Always reduce pressure with engine throttle to ensure the relief valve is closed before turning the four-way valve OFF.

WARNING

If the intake pressure increases greatly because of a reduction in flow, the relief valve will not be able to control the discharge pressure to the selected setting. The relief valve cannot control discharge pressure to an amount lower than intake pressure plus about 50 psi. When operating from draft or booster tank, the relief valve may not control at discharge pressures less than about 90 psi.

WARNING

Scalding Water Hazard. May result in serious burns.

When operating the pump, be sure to open at least one discharge valve slightly to prevent the pump from overheating. If the pump runs for a few minutes completely closed, it may heat the water enough to scald someone when the valve is opened. Overheating can damage the packing, seals and other pump parts. If the apparatus builder has installed a by-pass system or other provision designed to prevent overheating, opening a discharge valve may be unnecessary.

General Description

The Waterous discharge relief valve system provides sensitive pump control to protect firefighters from sudden pressure surges resulting from changes in discharge flows from the pump. Designed with a "built-in-memory," this system has a wide continuous range of pressure control from a minimum of 75 to a maximum of 300 psig depending upon pump performance characteristics, and may be put in or taken out of operation without disturbing the pressure setting. This allows you leave the system at a pre-set "ready-to-use" pressure setting.

The Waterous discharge relief valve system incorporates two separate units; a panel mounted pilot valve which controls the operation of the relief valve proper, and the relief valve which is normally mounted on the pump.

The pilot valve has two controls, one to adjust the relief valve operating pressure, and the other, an ON-OFF control, to place the relief valve in or out of operation.

The ON-OFF control lets the operator put the relief valve out of operation (hydraulically holding the relief valve closed) when a pressure higher than set pressure or higher than 300 psig is desired. Turning this control ON permits the relief valve to operate again at whatever pressure was previously set without further adjustment.

The relief valve is mounted on the pump or in the piping between the intake and discharge sides of the pump. It modulates flow between discharge and intake by ranging between the fully open and fully closed position in response to hydraulic signals from the pilot valve. The relief valve is available in three sizes. For pumps with rated capacities of 750 gpm or less, a two-inch outlet diameter relief valve is used. For pumps with rated capacities of 1250 gpm through 2250 gpm, a three-inch or 4-inch outlet diameter relief valve is used.

Two indicator lights show the position of the relief valve; green for fully closed and amber for at least partially open.

Figure 1. Pilot Valve

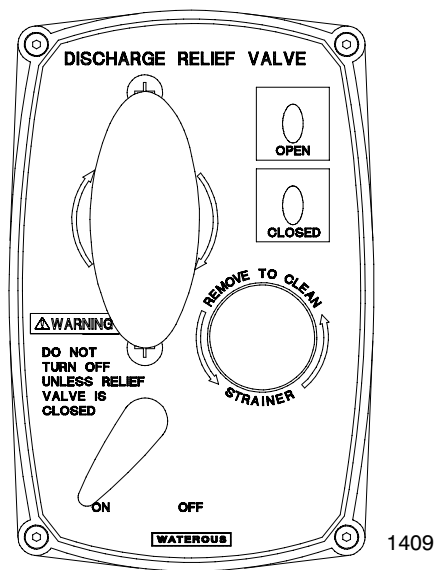

Pilot Valve - Mounted on the pump control panel. Hydraulically controls the operation of the relief valve.

Figure 2. Relief Valve

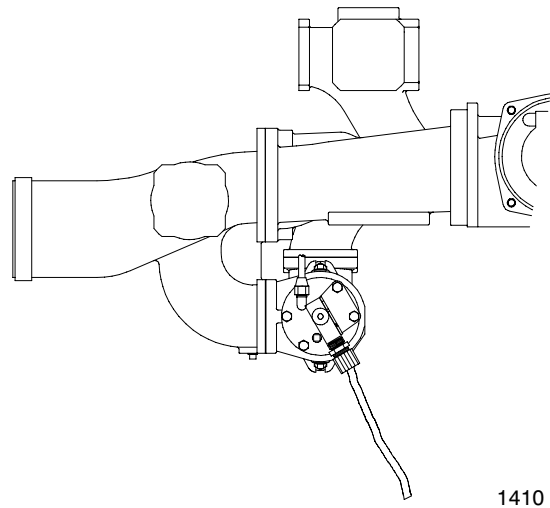

Relief Valve - Shown mounted between discharge and intake on a standard Waterous midship mounted pump.

Figure 3. Discharge Relief Valve Operation - OFF Position

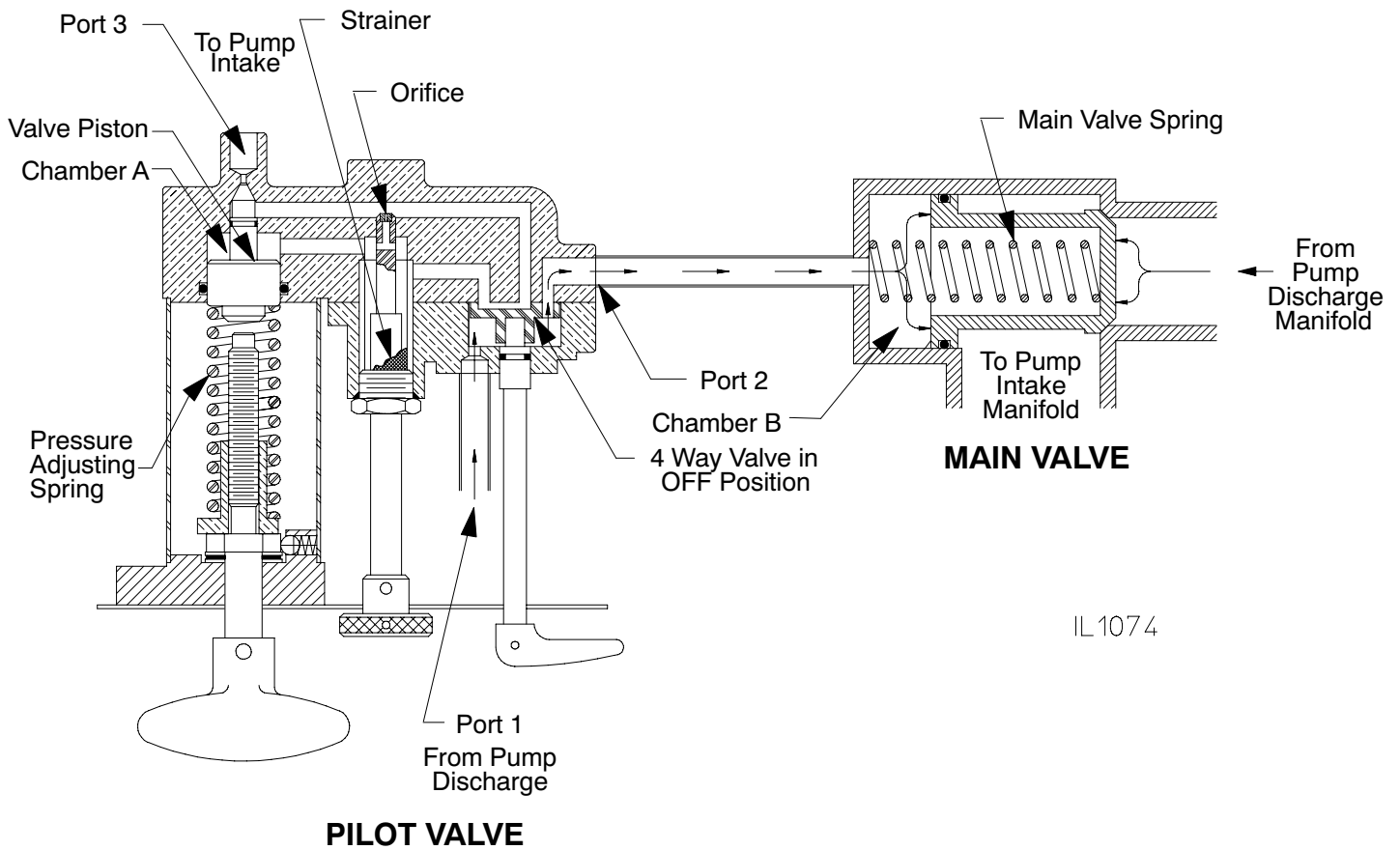

IL1074

With the pump operating, water enters the main valve from the pump discharge manifold at full discharge pressure. It also enters the four way valve at full discharge pressure through port 1. With the four way valve OFF, water passes through the four way valve and out port 2 to main valve chamber B, bypassing the pilot valve.

In this condition, water pressure is equal on both sides of the main valve. Since the valve diameter is greater at the flange end of the main valve than at the seating end, the total force applied to the flange end by water in chamber B is also greater. This force imbalance combined with the force of the main valve spring holds the main valve closed. The main valve remains closed, regardless of the discharge pressure.

The pilot valve is usually turned OFF only when discharge pressures above 300 psi are required, or if higher pressures are desired without the necessity of disturbing the pilot valve setting.

Figure 4. Discharge Relief Valve Operation - ON Position Main Valve Closed

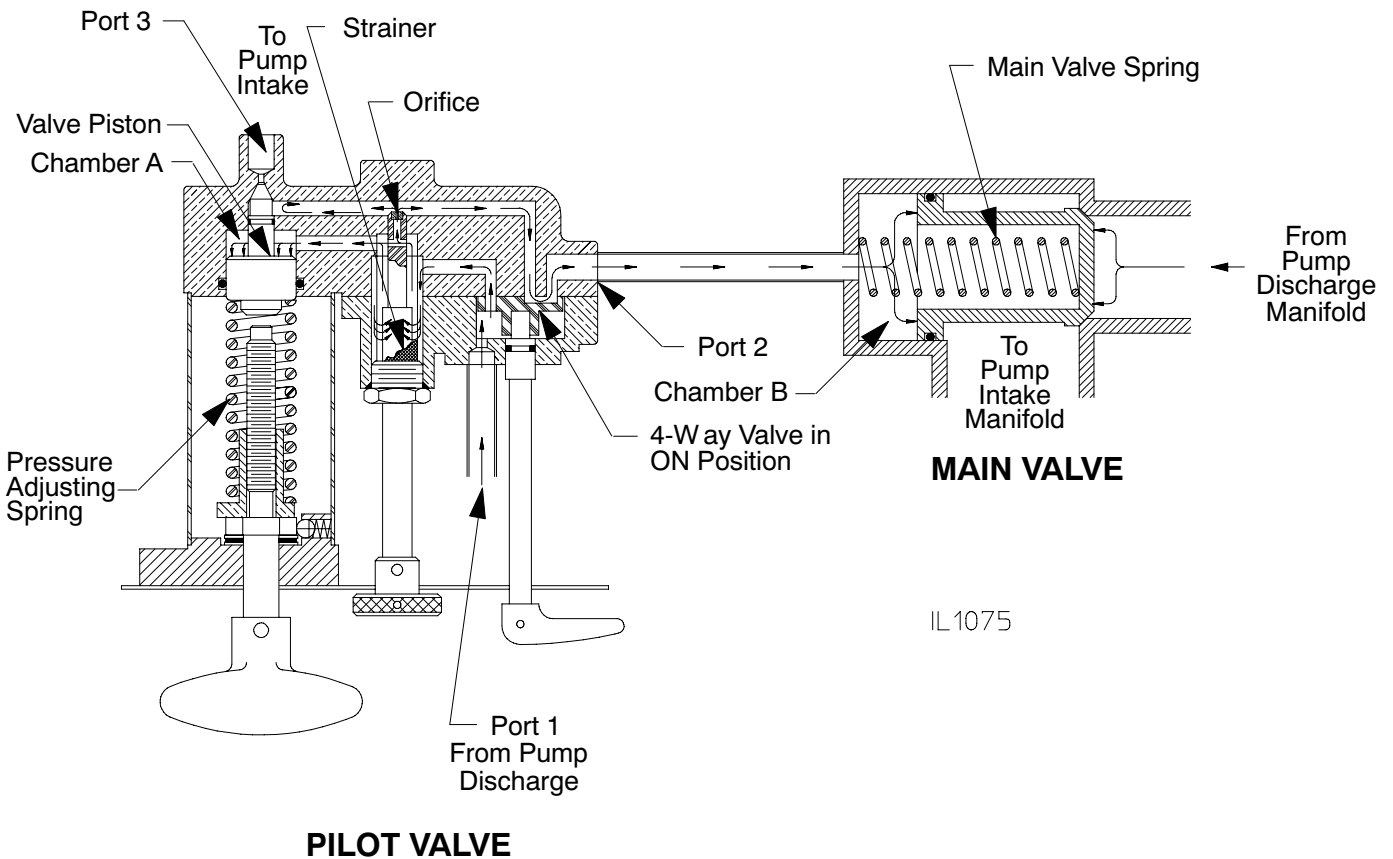

With the pump operating, water enters the main valve from the pump discharge manifold at full discharge pressure. It also enters the four way valve at full discharge pressure through port 1. With the four way valve ON, water passes through the strainer and fills chamber A above the valve piston. Water also passes through the orifice, back through the four way valve and out port 2 to the main valve chamber B.

In this condition, water pressure is equal on both sides of the main valve. Since the valve diameter is greater at the flange end of the main valve than at the seating end, the total force applied to the flange end by the water in chamber B is also greater. This force imbalance combined with the force of the main valve spring holds the main valve closed.

As long as pump discharge applies a load to the pilot valve piston that is less than the compression load of the pressure adjusting spring, the piston remains seated, preventing discharge through port 3 back to pump intake.

Figure 5. Discharge Relief Valve Operation - ON Position Main Valve Open

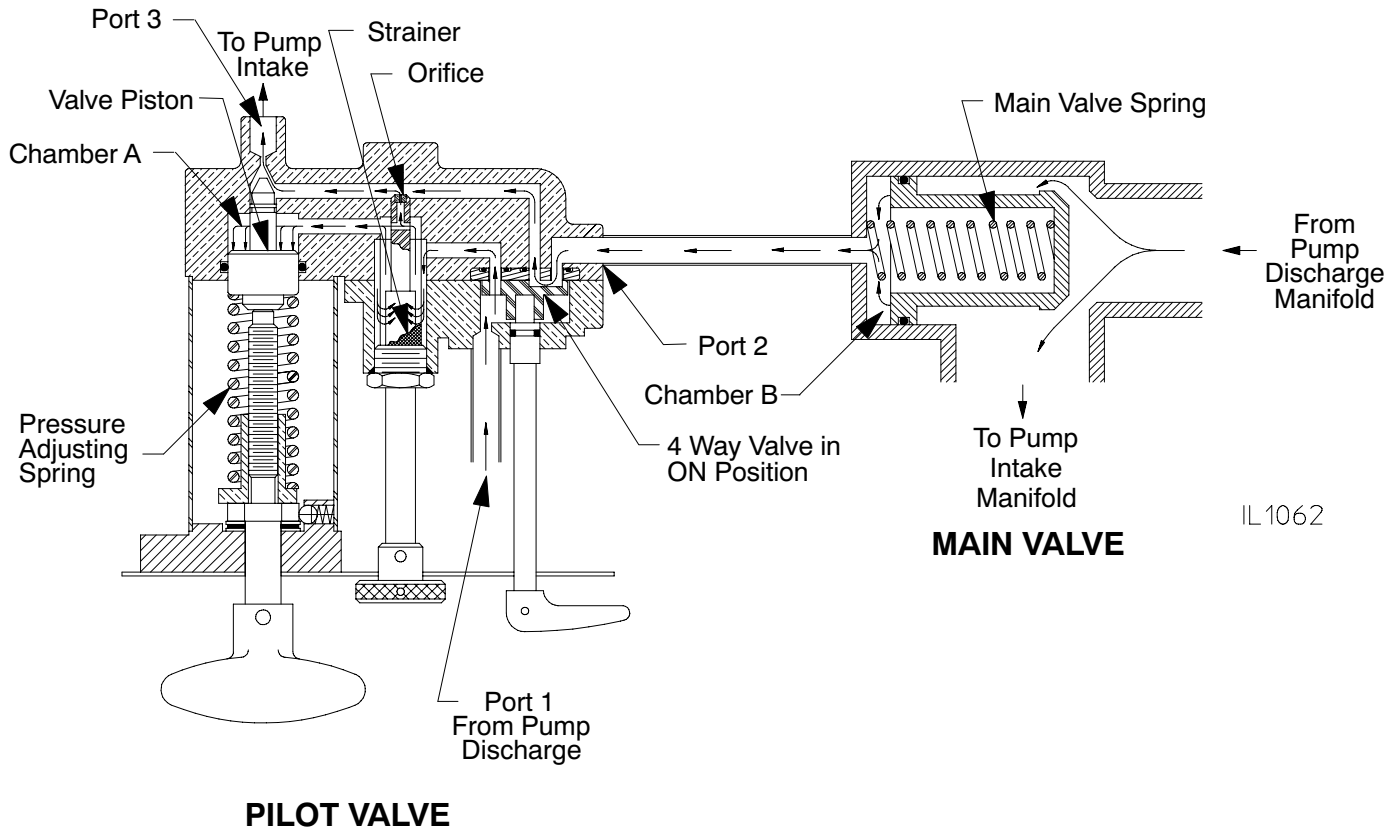

When a discharge valve is closed or the engine is accelerated, the pump discharge pressure in chamber A may exceed the compression load of the pressure adjusting spring. In this case the valve piston unseats and water is allowed to escape through port 3 to the pump intake. The orifice through which the water must flow from the pilot valve to the main valve causes the pressure in chamber B to be lowered. The force exerted on the seating end of main valve now exceeds that on the flanged end, and the valve opens. Some or all of the discharge water now bypasses from the discharge manifold back to the intake side of the pump.

If the discharge pressure drops below the compression setting on the pressure adjusting spring, the valve piston will reseat and stop flow through port 3 allowing pressure to build up in chamber B and reclose the main valve. Usually the pressure drops to a level where the pressure in chamber B increases enough to balance discharge pressure acting on the opposite end of the main valve, so the main valve is neither fully open nor fully closed.

Operating Instructions

To adjust the system for opening pressures below 300 psi, use the following procedure:

Note: To prevent minor pressure surges from opening the relief valve, many pump operators set the pilot valve about 5 psi above the intended discharge pressure

WARNING

Pressure Hazard. May result in personal injury.

Always reduce pressure with engine throttle to ensure the relief valve is closed before turning the four-way valve OFF.

1. Reduce pump discharge pressure with engine throttle. Make sure four way valve is OFF.
2. Open at least one discharge valve. Accelerate engine until pressure gage indicates relief valve opening pressure.
3. Turn four way valve ON.
4. Watch pressure gage or indicating lights:

Note: Indicator lights enable the pump operator to know at any time whether the relief valve is open or closed. A green light is on when the relief valve is closed, and an amber light shows when the valve is open.

- a. If gage reading drops below desired pressure (relief valve opens), turn pilot valve handle clockwise until pressure increases to desired value (relief valve closes).
- b. If gage reading does not drop, slowly turn pilot valve handle counterclockwise until gage pressure drops about 5 or 10 psi below desired setting (relief valve opens). Gradually turn handle clockwise until gage needle is steady at desired discharge pressure (relief valve closes).

5. The relief valve will now automatically prevent discharge pressures much greater than the one for which it is set. To readjust relief valve at a different pressure, repeat the procedure outlined in steps 1 through 4.

WARNING

If the intake pressure increases greatly because of a reduction in flow, the relief valve will not be able to control the discharge pressure to the selected setting. The relief valve cannot control discharge pressure to an amount lower than intake pressure plus about 50 psi. When operating from draft or booster tank, the relief valve may not control at discharge pressures less than about 90 psi.

Note: When the relief valve is open, water may be heard rushing through it at high velocity.

If discharge pressures greater than 300 psi are required, the four way valve must be OFF. This bypasses the pilot valve and keeps the relief valve seated, regardless of discharge pressures. Turning the four way valve does not disturb the pilot valve setting. To actuate the pilot valve, turn the four way valve ON.

After Pumping

If the relief valve will be exposed to freezing temperatures, turn the pilot valve on and open the drain cock in the relief valve cover to drain. Some systems may have a separate drain control for the pilot valve.

CAUTION

Failure to drain the valve in freezing weather may result in serious damage. Failure to close the valve after draining may cause the relief valve to stay open while pumping.

Maintenance Instructions

If the relief valve operation is sluggish or erratic, the cause can usually be traced to fine sand, grit or other foreign material clogging one of the valves or strainer. At least monthly, follow the exercise instructions below to ensure proper relief valve operation.

1. Engage the pump per appropriate instructions and increase pump discharge pressure to 150 psi.
2. With the pilot valve OFF, remove the strainer assembly. Clean the strainer and the orifice in the end of the rod.
3. Cover stainer opening with hand and slowly turn the pilot valve ON and OFF several times. Water should flow from the strainer opening in the ON position and the relief valve should open (amber light). The water flow should stop and the relief valve should close (green light) in the OFF position.
4. Check the strainer O-rings and replace if required; replace the strainer assembly (hand tight only).
5. With the pilot valve OFF, turn the pressure adjustment handle counterclockwise until it stops.
6. Slowly turn the pilot valve ON. The relief valve should open (amber light) and pump discharge pressure should decrease.
7. Slowly turn the pilot valve OFF. The relief valve should close (green light) and pump discharge pressure should rise back to 150 psi.
8. Repeat steps 6 and 7 until the system responds quickly when turned ON and OFF.
9. Reset the pilot valve to the desired setting and decrease engine speed to idle.

WARNING

Scalding Water Hazard. May result in serious burns.

When operating the pump, be sure to open at least one discharge valve slightly to prevent the pump from overheating. If the pump runs for a few minutes completely closed, it may heat the water enough to scald someone when the valve is opened. Overheating can damage the packing, seals and other pump parts. If the apparatus builder has installed a by-pass system or other provision designed to prevent overheating, opening a discharge valve may be unnecessary.

Service Checks (Indicator lights)

The relief valve system should normally require minimal attention other than the basic exercise procedure described on this page. If the procedure does not correct relief valve operation, follow the instructions below.

Open relief valve drain, drain cock on the relief valve cover (if it is accessible), or unfasten the connection between the pilot valve and relief valve (at the relief valve). If the pressure then decreases, the relief valve is not stuck, and the trouble can be attributed to the pilot valve. If the pressure does not decrease, however, the main valve is stuck.

If either pilot valve or relief valve is inoperable, disassemble, clean and rebuild according to the instructions provided in the repair kit for each item.

These indicating lights usually require no attention other than routine bulb replacement. The information below is necessary only if more extensive repairs are required, or the valve is disassembled for any reason.

If the indicator lights do not work properly, check out the indicating system as directed below.

1. Make sure switch is adjusted properly as directed below.
2. Check all wiring for loose terminals, damaged insulation or broken wire strands, especially near terminals. Make sure ground wire is firmly connected to a mounting screw.
3. Connect a jumper wire alternately between a ground and the harness terminals on the indicator lights to make sure bulbs and sockets are in good order. Replace bulbs or sockets as necessary.
4. Manually operate control switch. If lights do not operate in sequence (amber light on when switch plunger is depressed, and green light on when it is released), the switch is probably defective, and should be replaced.

If the switch is replaced or has been temporarily removed from its mounting bracket, adjust the clearance between the switch plunger and actuating rod so that insertion of a 0.015 inch feeler gage will light the amber indicator, but insertion of a 0.010 inch gage will not.