

Cable Operated, Remote Mounted Drain Valves

Operation and Maintenance

Form No.	Section	Issue Date	Rev. Date
F-1031	2308.1	12/03/93	08/16/10

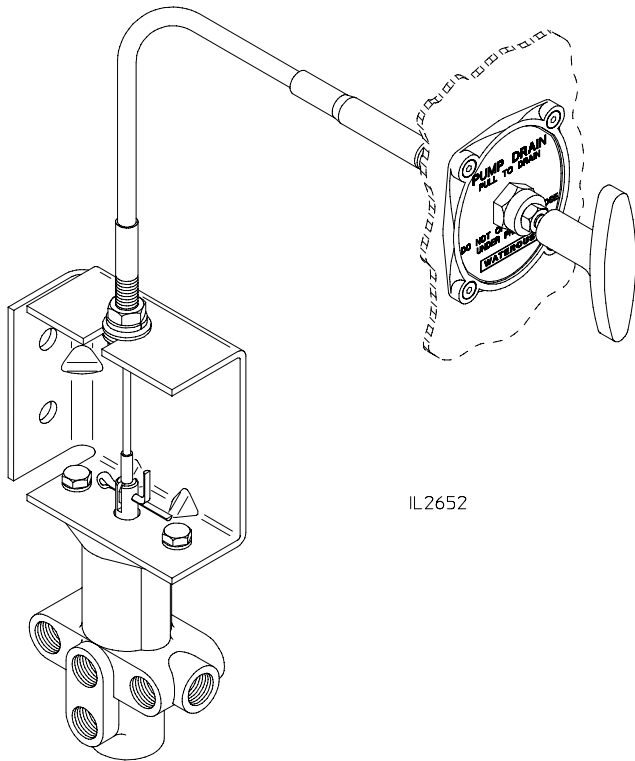

Table of Contents

General Description	2
Operating Instructions	2
Maintenance	2
Drain Locations, CM Series Pumps	3
Drain Locations, CS Series Pumps	3
Explanation of Drain Valve Ports	4



Read through the installation instructions carefully before installing your Waterous Drain Valve.



Visit us at www.waterousco.com

Introduction

This instruction contains the information needed for operation and maintenance of the Cable Operated Drain Valve.

General Description

The Waterous manifold drain valve allows drainage of the fire pump and most related equipment with a single panel-mounted control, eliminating the need to open several petcocks every time the pump and accessories need to be drained. The manifold drain valve consists of a stainless steel plunger in a bronze body which has multiple 1/2 inch NPT ports. It is designed to use discharge pressure to keep the valve shut during operation.

Intake and discharge ports on the drain valve are isolated when the plunger is closed, to prevent flow from pump

discharge back to pump intake through the drain valve.

The drain valve provides for flexibility in mounting arrangements and can be mounted on the pump transmission case on pumps equipped with split shaft transmissions, or in almost any other convenient locations. A convenient panel-mounted push-pull cable control operates the valve.

A special U-cup packing arrangement tightly seals pump and accessory drain ports from the atmosphere.

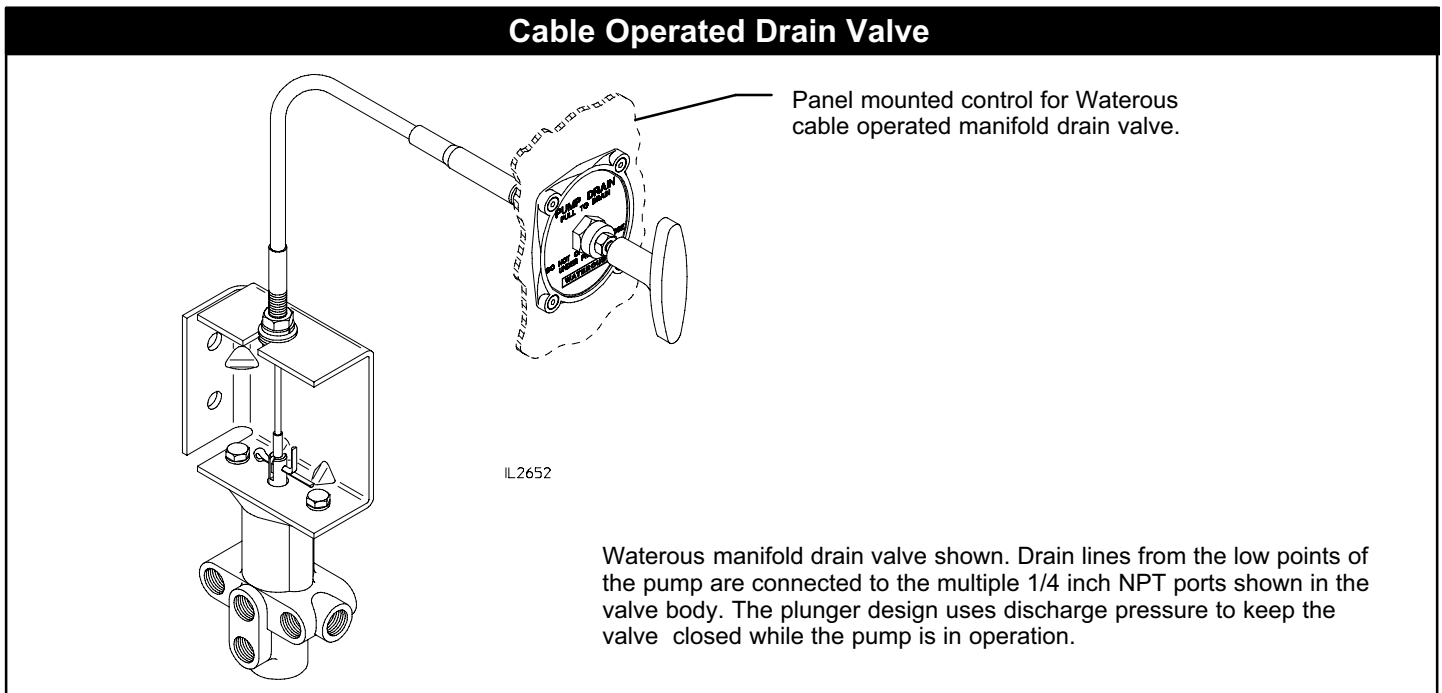

Operating Instructions

To Open Valve

Pull the control knob out until the drain valve is in the full open position (approximately 1-7/8 inch of travel).

CAUTION

Do not open drain valve with pump running. Pump discharge pressure holds the valve closed. Attempting to force the valve open under pressure may damage the cable or valve.

To Close Valve

Push the control knob in as far as it will go and tap sharply with palm of hand to seat plunger.

CAUTION

Do not close drain valve with pump running. Damage to the seals may result.

Maintenance

Sand or other foreign particles in the water may settle in the drain valve. At least once per month, open the drain valve to flush out the valve and the lines. If the valve is difficult to open, it may be tapped upward from the bottom with a suitable punch.

CAUTION

Do not open or close the valve under pressure. Damage to the cable or seals may result.

Drain Locations, CM Series Pumps

Bottom View

Forward
↑

Discharge Pilot Valve
(On apparatus panel)
Drain Separately

Discharge Relief Valve Cap
Drain Separately

Discharge Relief Valve

Manifold Drain Valve

(Optional both ends)

- ① 1st Stage Volute
- ② 2nd Stage Volute
- ③ 2nd Stage Intake
- ④ Transfer Valve
- ⑤ Main Discharge Barrel
- ⑥ Relief Valve Elbow or Adapter
- ⑦ Relief Valve Body
- ⑧ Intake Fittings (Depends on type of Intake fitting)
- ⑨ Seal Cooling Line

NOTE: If the pump has a foam manifold, its drains should be plumbed into a separate drain valve. Do not plumb into drain valve used for the pump.

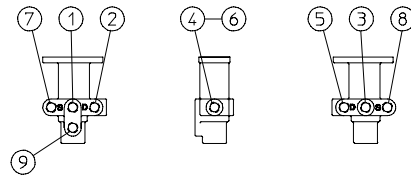

Manifold Drain Valve Details

Drain Locations, CS Series Pumps

Bottom View

Forward
↑

Discharge Pilot Valve
(On apparatus panel)
Drain Separately

Discharge Relief Valve Cap
Drain Separately

Discharge Relief Valve

Manifold Drain Valve

(Optional both ends)

- ① Intake Volutes
- ② Discharge Volute
- ③ Crossover Passage
- ④ Main Discharge Barrel
- ⑤ Relief Valve Elbow or Adapter
- ⑥ Relief Valve Body
- ⑦ Intake Fittings (Depends on type of Intake fitting)
- ⑧ Mechanical Seal/Packing Chambers

NOTE: If the pump has a foam manifold, its drains should be plumbed into a separate drain valve. Do not plumb into drain valve used for the pump.

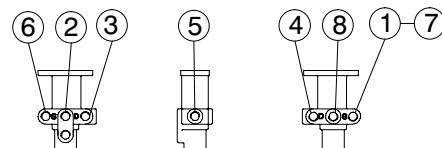

Manifold Drain Valve Details

Drain Valve Ports

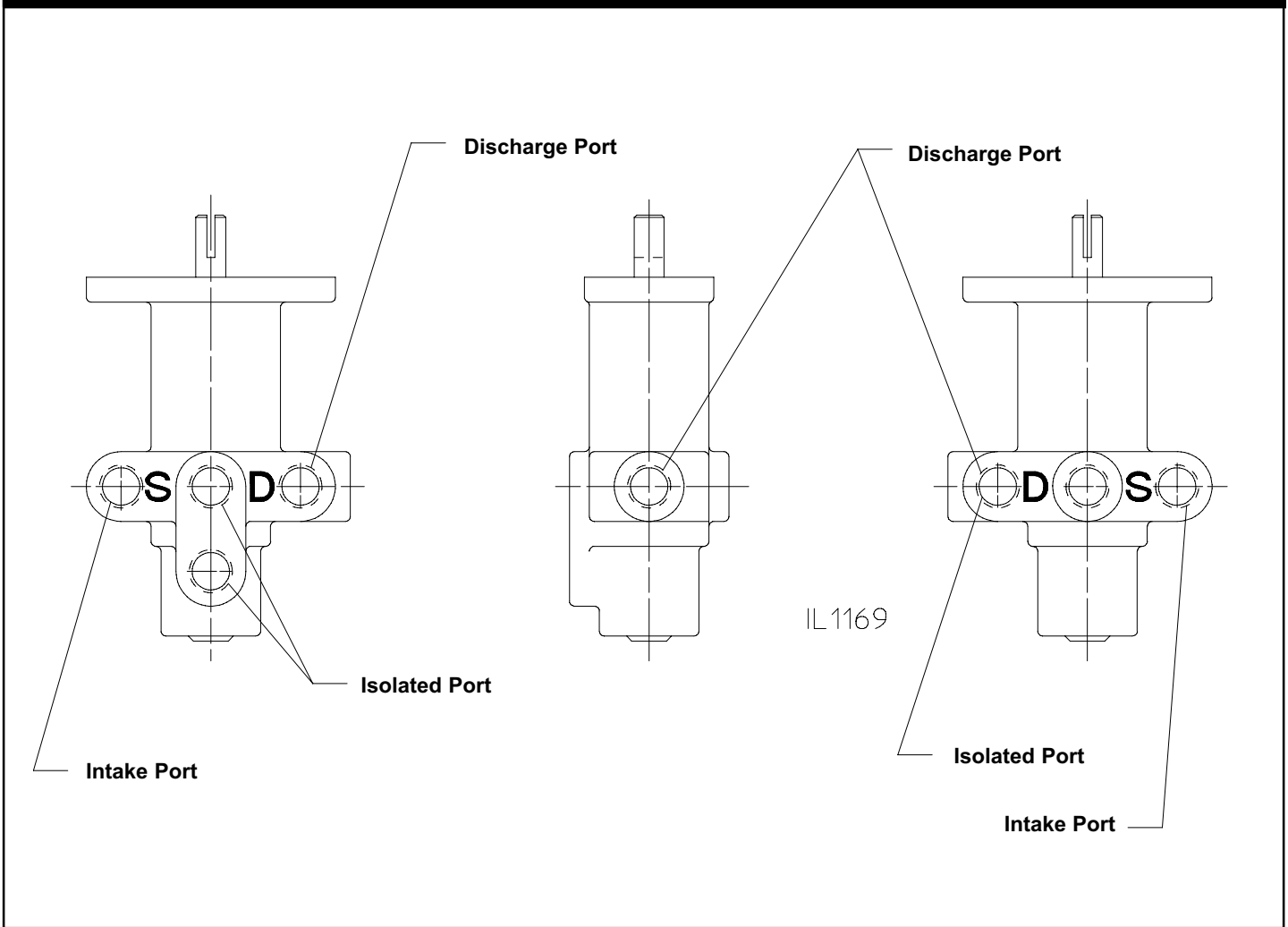

Explanation of Drain Valve Ports

Discharge Ports (3)

All pump and accessory passages which are normally under full discharge pressure.

Intake Ports (2)

All pump and accessory passages which are connected to pump intake.

Isolated Ports (3)

Pump passages such as first stage discharge and second stage intake are connected here. These ports are not connected to pump intake and are not under full discharge pressure.

Note: The following drain valves are not to be connected to the drain valve. Separate drains must be used for these.

- Intake relief valve cap
- Discharge relief valve cap
- Discharge pilot valve (on apparatus panel)
- Extra pressure stage (model CMH or CSH pumps)
- Foam manifold
- Passageways which carry foam