

Table of Contents



Read through the installation instructions carefully.

NOTE: Instructions subject to change without notice.

SECTION 1. INSTALLATION OVERVIEW	4
SECTION 2. INSTALLING THE WATEROUS COMPONENTS	5
A. PTO Installation	5
B. Air Compressor Installation	6
I. Using the mounting flange with a bracket	9
II. Compressor Oil Discharge	11
III. Connecting the Compressor to the PTO	11
C. Air Inlet and Filter	11
D. Air-Oil Reservoir (Sump) Installation.....	12
E. Optional Oil Check Valve	14
I. Vertical Sump	15
II. Horizontal Sump (Optional).....	15
III. Oil Fill and Sight Glass.....	17
F. Oil Temperature Gauge (all sumps).....	18
G. Separator Installation	19
H. Heat Exchanger Assembly Installation	20
I. Connecting the cooler water lines and wye-strainer	21
II. Wye Strainer for Cooler.....	21
I. Auto-Sync Control System Installation.....	23
I. Electric Valves (Solenoids)	23
II. Manual.....	24
J. Balance Valve Installation.....	25
K. Air Pressure Gauge	26
SECTION 3. INITIAL POWER-UP	27
A. Post-Installation, Pre-Power Up Safety Check	27
B. Initial Compressor System Power-up.....	27
SECTION 4. INITIAL ADJUSTMENT OF THE AUTO-SYNC AIR BALANCING SYSTEM	27
A. Electric Auto-Sync Initial Setup.....	28
I. UNLOAD Mode Initial Setting.....	28
II. FIXED Mode Initial Setting.....	30
III. AUTO Mode Initial Setting.....	30
B. Manual Auto-Sync Initial Setup.....	32
I. UNLOAD Mode Initial Setting.....	32
II. FIXED Air Initial Setting:.....	33
III. AUTO Air Initial Setting:	33
SECTION 5. SUGGESTED THIRD-PARTY COMPONENTS	35
A. Suggested components for CAFS discharges:	35
B. Suggested Hose	36
I. Push-on.....	36
II. Air Brake.....	36
III. Hydraulic	36
C. Power take-off suggestions.....	37
SECTION 6. TROUBLESHOOTING GUIDE	38
A. Troubleshooting - CAFS	38
SECTION 7. DRAWINGS	42
SECTION 8. BASIC DRIVELINE INSTALLATION SUGGESTIONS	60
A. U-Joint Operating Angles.....	60
I. Reducing and Canceling Vibration	60
B. Single Plane and Compound U-Joint Operating Angles	60
I. Single Plane	60
II. Compound Angles.....	63
III. True U-Joint Operating Angle	63
IV. Angle Size	64
C. Eliminating Compound Angle Induced Vibrations.....	65
SECTION 9.CONDITIONAL 5-YEAR WARRANTY POLICY	68

Warnings, Cautions, and Notes

Warning	A warning alerts you to a procedure, practice or condition that may result in death or long term injury to personnel or destruction of equipment.
----------------	---

Caution	A caution alerts you to a procedure or condition that may result in serious damage to equipment or its failure to operate as expected
----------------	---

Note: A note points out important information. Failure to read the note may not result in physical harm to personnel or equipment. It may waste time and money.

ATTENTION:

Defects in replacement part(s), component(s) or product(s) manufactured by others and furnished by WATEROUS is understood that the only warranty provided for such replacement part(s), component(s) or product(s), shall be the warranty provided by the manufacturer of said replacement part(s), component(s) or product thereof which, if assignable, WATEROUS will assign to Buyer, if requested by Buyer.

Defects in replacement part(s), component(s) or product(s), not furnished by Waterous, but suggested in the installation guide, are the responsibility of the installer and the manufacturer of said replacement part(s), component(s) or product(s). Waterous will not be responsible for any replacement part(s), component(s) or product(s) that are not furnished or purchased from Waterous.

WARRANTY INSERT: (last page)

The aforesaid warranty excludes any responsibility or liability of WATEROUS for:

- c) any product or part, altered, modified, serviced or repaired other than by WATEROUS, without its prior written consent; and
- d) the cost of dismantling, removing, transporting, storing, or insuring the defective product or part and the cost of reinstallation.

Disclaimer: These instructions are guidelines only and in no way meant to be definitive. During installation, standard safety precautions and equipment should be used where appropriate. Because the tools used and the skill/experience of the installer can vary widely, it is impossible to anticipate all conditions under which this installation is made, or to provide cautions for all possible hazards. Proper installation is the responsibility of the purchaser. All bolts, setscrews, and belts must be checked prior to start-up AND after the initial operation. Damages due to poor installation are the responsibility of the installer.

Waterous reserves the right to make modifications to the system without notice

Figure(s)

Figure 1 Compressor, side view	7
Figure 2 Compressor Bottom mounting bolt pattern	8
Figure 3 Compressor and Mounting bracket.....	8
Figure 4 Compressor with Oil Discharge Fitting Installed	11
Figure 5 Compressor input shaft and companion flange	11
Figure 6 Typical compressor with drive shaft connected.	11
Figure 7 Sump height to Compressor.....	13
Figure 8 Optional Oil Check Valve.....	14
Figure 9 Horizontal sump, inlets and outlets.....	16
Figure 10 Oil fill and sight glass in a Wye fitting	17
Figure 11 Ideal installation, with sight glass and oil fill easy to access	17
Figure 12 90° Elbow on a sight glass for better visibility	17
Figure 13 Two elbows on an oil fill cap for accessibility.....	17
Figure 14 Separator/filter side view with fittings.....	19
Figure 15 Separator/filter and bracket detail.....	19
Figure 16 Hydraulic Filter, top, showing flow direction arrows	21
Figure 17 Wye Strainer.....	22
Figure 18 Wye-strainer installed, with cleanout valve.....	22
Figure 19 Clean Strainer.....	22
Figure 20 Dirty Strainer.....	22
Figure 21 Typical Air Pressure Gauge.....	26
Figure 22 Manual Control Panel	32
Figure 23 Piloted Balance Trim Valve (PBTV).....	32
Figure 24 Typical CAFS Discharge.....	35
Figure 25 Basic CAFS Schematic.....	42
Figure 26 Vertical Sump Kit	43
Figure 27 Horizontal Sump Kit (Optional)	44
Figure 28 Compressor Dimensions	45
Figure 29 Companion Flange, 28mm Bore.....	46
Figure 30 Vertical 8" Sump.....	47
Figure 31 Horizontal 6" Sump (Optional)	48
Figure 32 Cooler and Hydraulic Filter Assembly.....	49
Figure 33 Piloted Balance Trim Valve (PBTV).....	50
Figure 34 Compressor Installation Angles	51
Figure 35 Separator Filter Assembly	52
Figure 36 Separator Bracket.....	53
Figure 37 Hydraulic Schematic, Vertical Sump.....	54
Figure 38 Hydraulic Schematic, Horizontal Sump (Optional).....	55
Figure 39 Air Schematic, Manual Auto-sync, Vertical Inlet	56
Figure 40 Air Schematic, Electrical Auto-sync, Vertical Inlet	57
Figure 41 Electric Schematic, Auto-sync	58
Figure 42 Auto-sync Panel Cutouts	59
Figure 43 Operating Angle.....	60
Figure 44 Angles in the side view	61
Figure 45 Angles in the top view.....	61
Figure 46 Angle Chart.....	62
Figure 47 Compound Operating Angles	63
Figure 48 Operating Angle - Uphill.....	66
Figure 49 Operating Angle - Downhill.....	67
Figure 50 Driveline Run-out Spec.....	68

SECTION 1. INSTALLATION OVERVIEW

Notes: The instructions are for a typical system. A custom order system will have a similar installation procedure.

The illustrations shown in this manual may differ slightly from the parts that were shipped.

The primary use of the compressor kits is to provide compressed air for Compressed Air Foam Systems (CAFS) in fire-fighting vehicles. Water to cool the compressor is supplied by the vehicle's pump, from its tank or an exterior source. If the kit is not installed in a fire-fighting vehicle, the compressor requires alternate cooling, such as an air-oil cooler.

The compressor kits do not include:

- (PTO) Transmission power take-off and drive shaft
- Foam proportioner, foam tank, foam distribution manifold for CAFS
- Air, water and hydraulic hoses and hose fittings
- Air and water check valves
- Air discharge valves
- Air manifold
- Master air pressure gauge

New installation tasks include:

- Installing the PTO (follow the manufacturer's instructions)
- Installing the foam proportioner (follow the manufacturer's instructions)
- Installing the compressor and connecting it to the PTO
- Installing the rest of the hydraulic system (sump, filters, and cooler)
- Installing gauges, valves, and the Auto-Sync controls
- Running water, air and hydraulic tubing for control systems, cooling, and compressed air delivery.
- Filling and testing the hydraulic system
- Calibrating the Auto-Sync system

Retrofitting into existing apparatus also includes:

- Modifying the water distribution system to install compressed air inputs, foam distribution manifold, check valves, the compressor cooling loop, and the balance valve.
- Installing additional discharges (optional)

SECTION 2. INSTALLING THE WATEROUS COMPONENTS

Refer to the Basic CAFS, Hydraulic, and Auto-Sync schematics in this manual to see how the Waterous components connect to the vehicle's foam and water distribution systems. Within the guidelines given here, components can be installed wherever there is room for them to be securely mounted. See the dimensional drawings in the rear.

Warning: Do not damage the vehicle chassis (also called frame or undercarriage) during installation. Check with the vehicle manufacturer to make sure the planned welds and bolts are in acceptable areas.

- Components must be bolted to brackets welded to the pump compartment frame, or bolted directly to the pump compartment frame.
- Allow enough clearance for routine maintenance, including clearance for checking oil, adding oil, adjusting pressure, changing filters, cleaning screens, or opening drain valves.
- The compressor must be horizontal, with its drive angle matched to the PTO.
- The sump (oil/air reservoir) can be mounted at the same level as the compressor, or below it. If the sump must be mounted above the compressor (12 inches maximum), contact Waterous for the correct check valve to prevent compressor flooding.
- The sump must be vertical, level, and in the proper orientation. Any extension to the sight glass must be straight and level.
- The oil sight glass must be visible after all the components are installed so oil level can be monitored easily.
- The heat exchanger must be installed horizontally, with the drain at the lowest point.
- To prevent damage to hydraulic and air lines, or accidentally disconnecting them, run them along the support beams of the pump compartment whenever possible, bundled with cable ties or other fasteners.
- Wires, hoses, or tubing that passes through metal, such as a compartment panel, must have a protective bushing or shield around the edge of the hole to protect against abrasion.
- To make troubleshooting easier, use colored air hoses and shown on the air schematic.
- Labeling the lines is strongly recommended.

A. PTO Installation

Follow the PTO manufacturer's installation guidelines.

Remember that the driveline angles on the compressor need to match the driveline angles on the PTO. If you have questions concerning driveline angle, please contact the driveline supplier.

Caution: Because the compressor is cooled by water from the fire pump, we strongly suggest that the compressor be disabled when the pump is off. This is accomplished by using the "OK to PUMP" circuit to trigger the PTO system.

Wiring the PTO switch circuit in parallel with the "OK to Pump" light is one way to ensure that the PTO and compressor cannot be activated unless the fire pump is engaged.

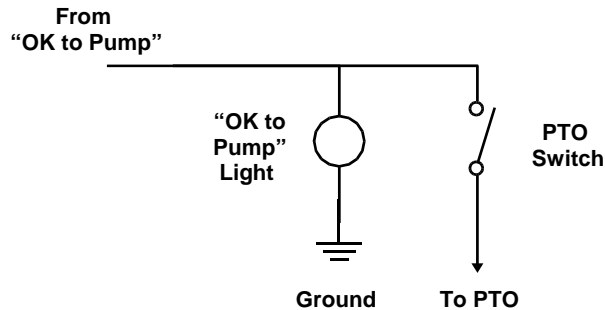

B. Air Compressor Installation

Warning: Drive flanges may be loosely installed for shipping purposes only. They must be securely fastened during driveline installation process.

All fasteners should be checked by the installer prior to operating the unit.

Caution: The air compressor cannot be installed on its side. It must remain upright, with the air intake on the top.

Incorrect driveline angles between the PTO and the compressor input shaft can lead to driveline failure and/or cause the air compressor to fail. If you have questions concerning driveline angles, please contact your driveline supplier.

Note: Looking towards the front of the vehicle, the compressor is usually installed on the left side of the main drive shaft. Installation on the right side of the shaft is possible, but usually more difficult.

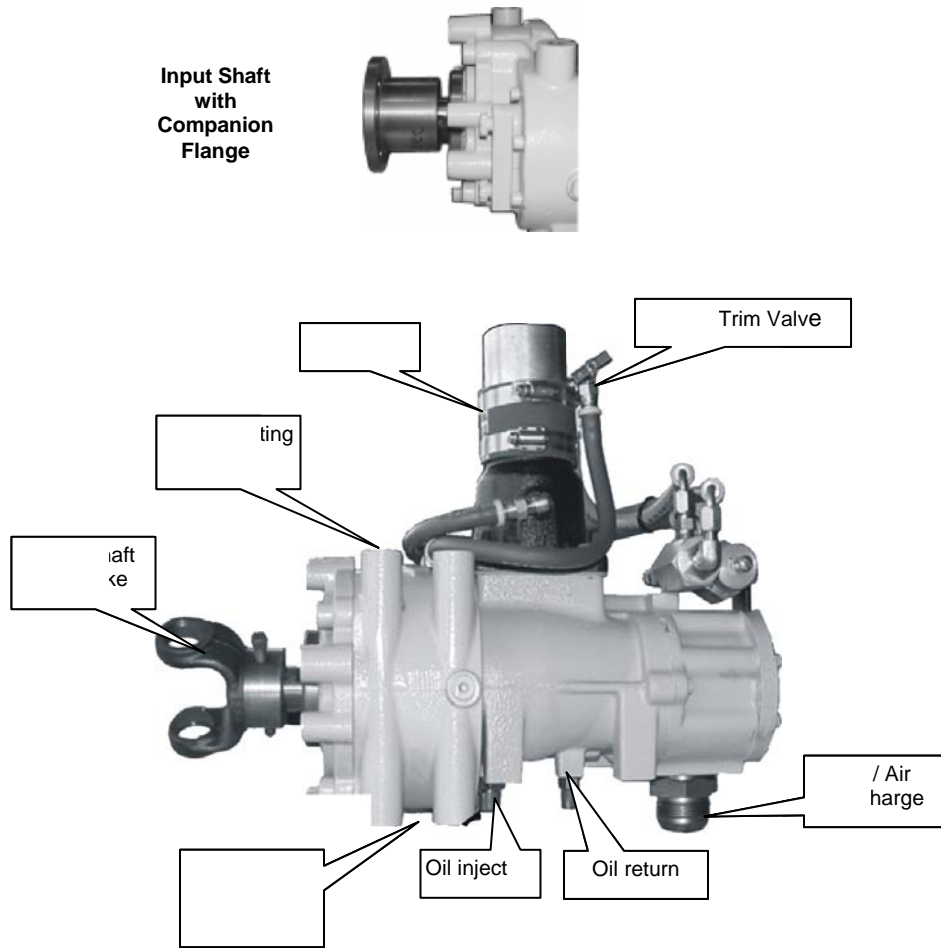

Figure 1 Compressor, side view

The mounting bracket is included with the system. The correct metric mounting bolts (12 mm) are provided with the compressor kit.

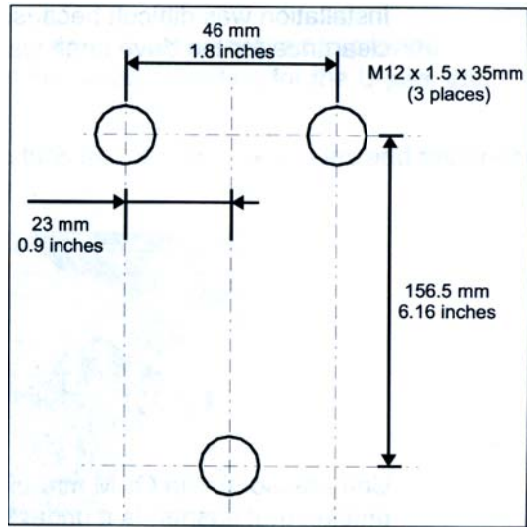

Figure 2 Compressor Bottom mounting bolt pattern
(center to center)

The bracket arm is bolted in place, using the vertical extension and the adjustable mounting bracket moved left or right to position the compressor. After the position is determined, weld the mounting bracket to the bracket arm to secure the compressor.

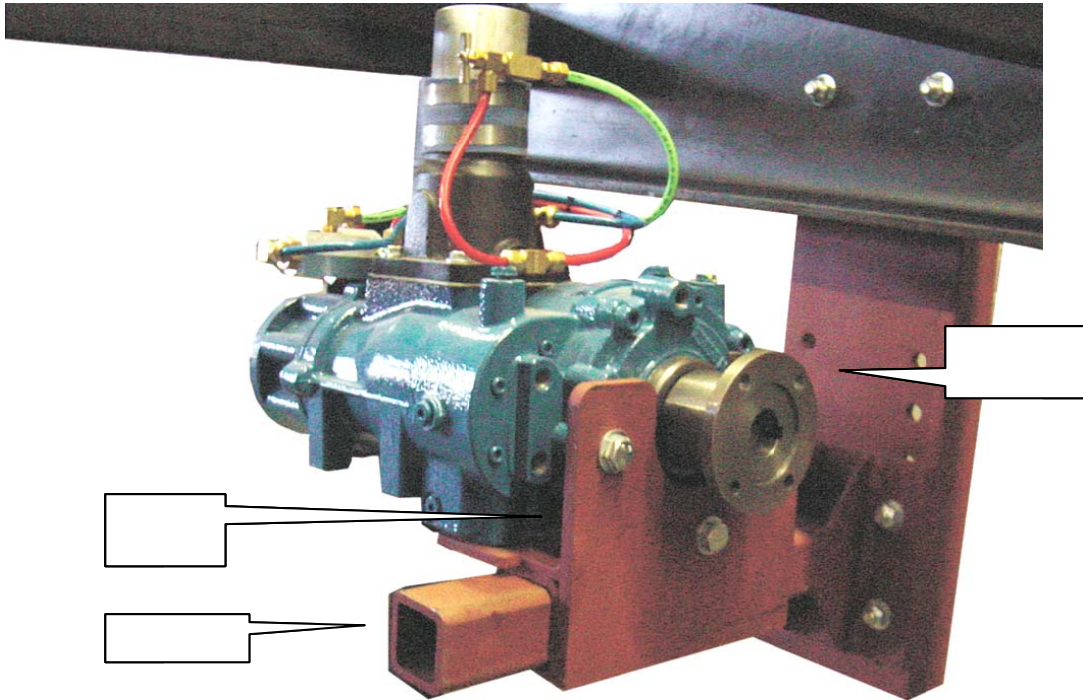
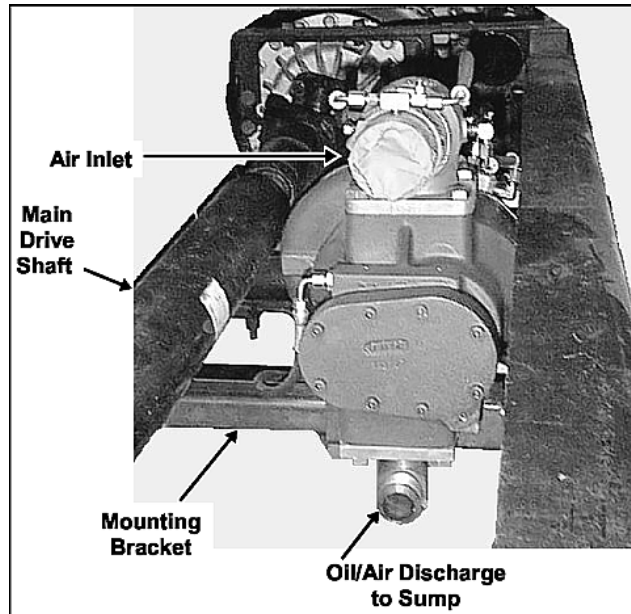

Figure 3 Compressor and Mounting bracket

Compressor on universal bracket in a non-typical installation.

The vehicle had a PTO-driven pump on the left side of the drive shaft. Installation was difficult because the clearance for the drive shaft was tight.



Compressor on an OEM manufactured bracket that suspends it under the pump cabinet.

The main drive shaft is to the left of the compressor.

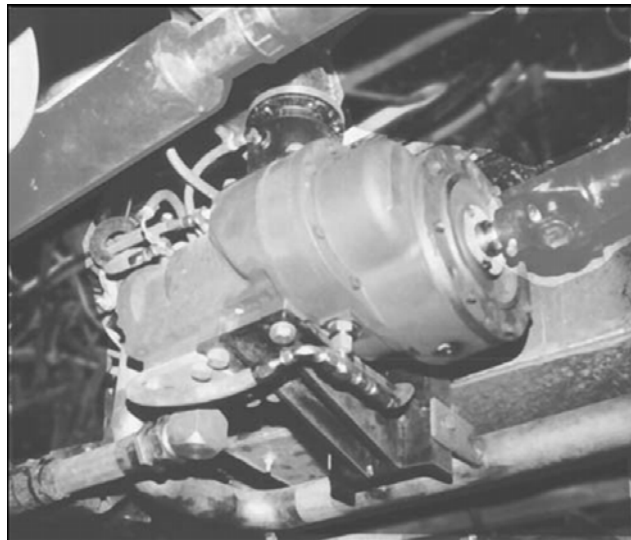

I. Using the mounting flange with a bracket

A bracket of this style must fit at least half way around the input shaft, using a minimum of 3 studs (M8 x 1.25 x 25) in the flange and through the mounting plate for a secure mount. This mounting method does not require any supports under the compressor (see illustration on page 9).

1/2-inch steel is the recommended material. The bracket must be braced to provide adequate support. Typically the bracket is part of the safety shielding for the U-joint and compressor input shaft.

Remove the cap screws, insert (M8 x 1.25 x 25) studs into the exposed holes and fasten the compressor to the bracket with 8mm locking nuts.

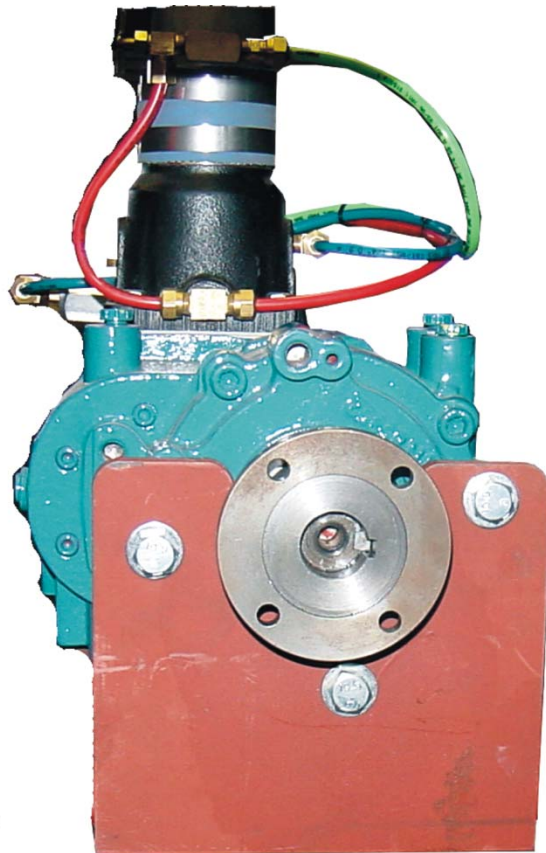

Compressor mounting flange

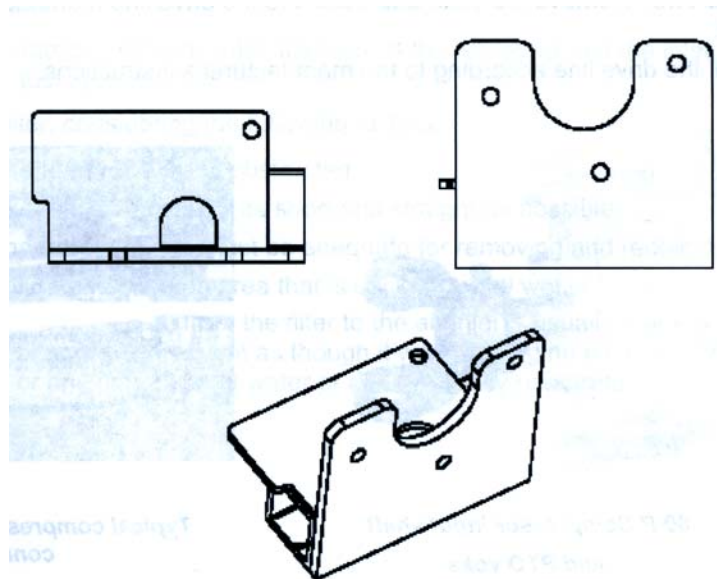

Typical face plate for a compressor mounting bracket

II. Compressor Oil Discharge

Pull the protective cover off of the discharge area, and remove any plastic protectors that may be in the discharge opening.

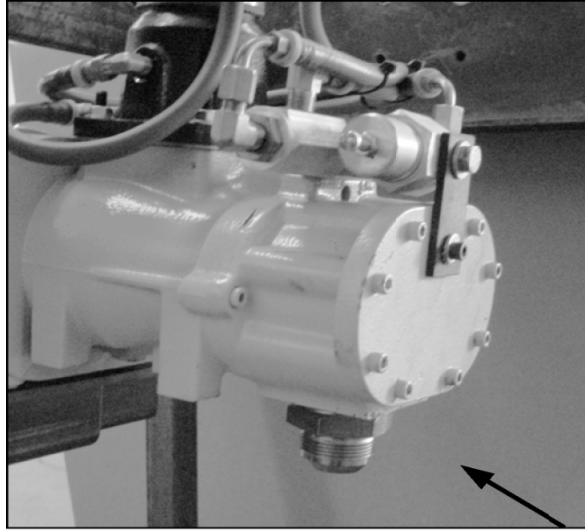

Figure 4 Compressor with Oil Discharge Fitting Installed

III. Connecting the Compressor to the PTO

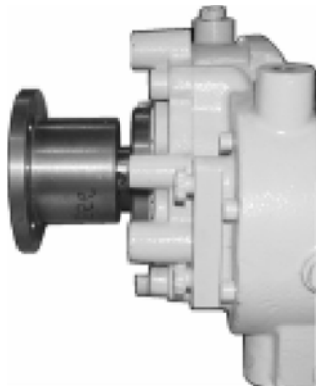

Figure 5 Compressor input shaft and companion flange

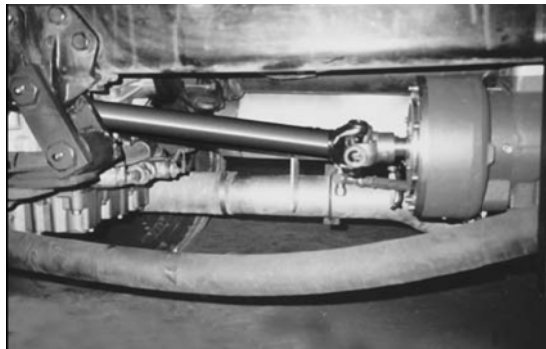

Figure 6 Typical compressor with drive shaft connected.

The compressor is shipped with the companion flange attached to the input shaft by the two set screws.

Install the drive line according to the manufacturer's instructions.

C. Air Inlet and Filter

Mount the air filter, considering the following factors:

- Air intake area must be unobstructed.

- Air intake tubing should be as short and straight as possible.
- Maintenance clearance must be adequate for removing and replacing the filter.
- The filter should be in an area that is unlikely to get wet.

The air inlet tubing (included) from the filter to the air inlet is usually made of thin-wall metal tubing and rubber elbows. Plumb it as though it were an engine air inlet. Do not use flexible exhaust tubing or any material that water or dirt can easily penetrate.

D. Air-Oil Reservoir (Sump) Installation

Note: Waterous will not be responsible for systems where the sump and sight glass are installed such that the oil level cannot be checked or does not display the correct oil level due to improper installation.

The sump works best when it is installed so that the sight glass opening is below the discharge outlet of the air compressor, although mounting the sump at the same level as the compressor is acceptable. In some cases, finding room for the sump can be difficult. It is acceptable to mount the oil sump up to 12 inches higher than the air compressor. However, over 12 inches will require the installation of a check valve (Figure 8) to prevent oil from flooding the compressor.

The check valve may be ordered from Waterous when ordering the system.

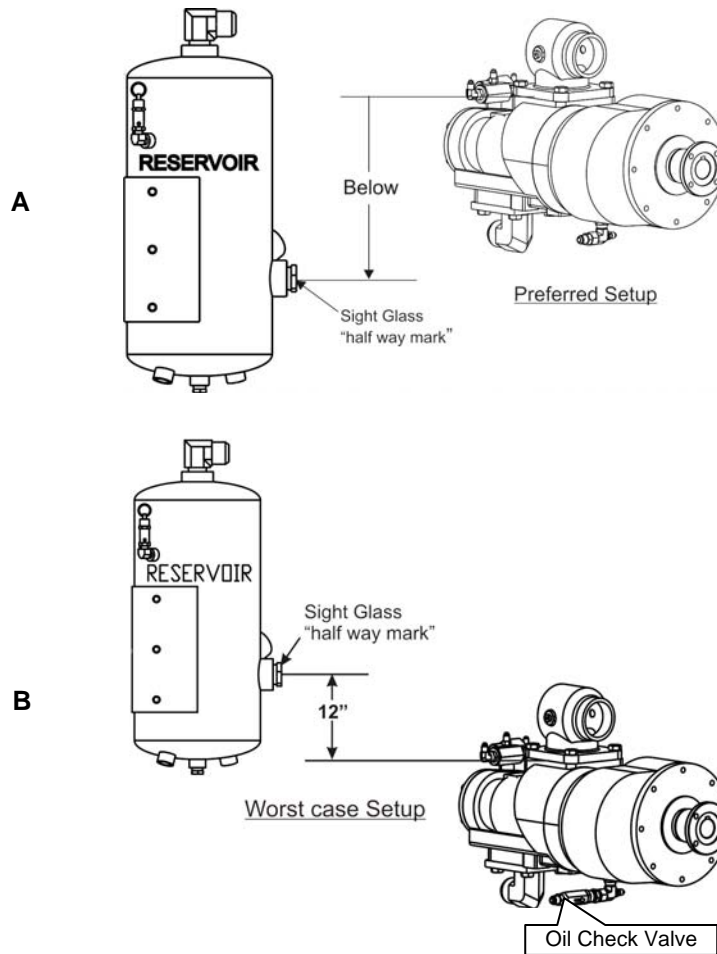

Figure 7 Sump height to Compressor

E. Optional Oil Check Valve

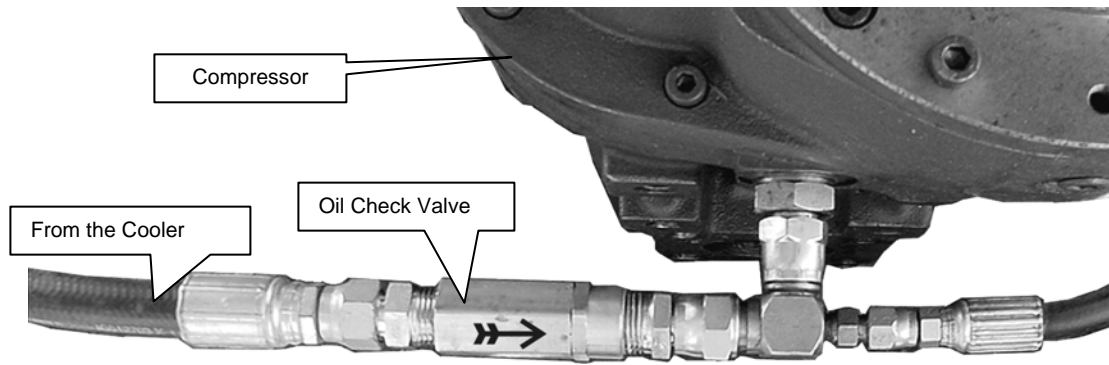

Figure 8 Optional Oil Check Valve

I. Vertical Sump

Vertical sump fittings



Vertical sump, rear view

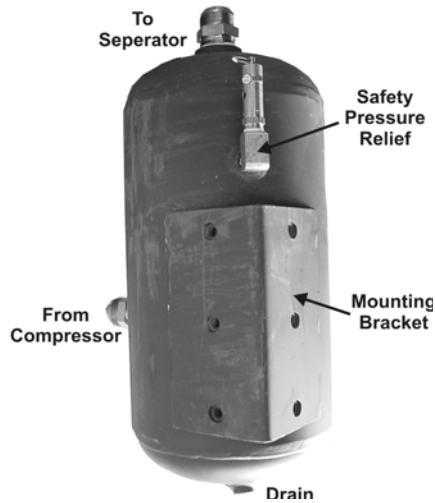

Vertical sump, bottom view

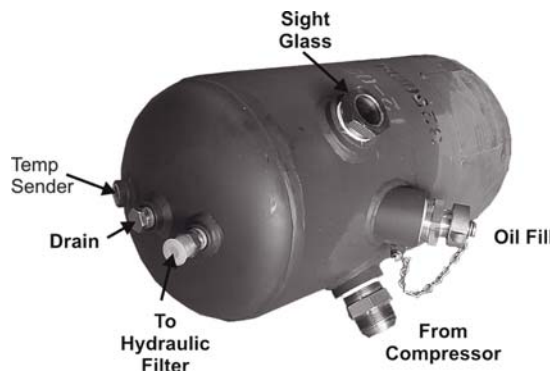

Note: Some models of this sump may have alternate connection for temperature sender at plug by oil drain.

II. Horizontal Sump (Optional)

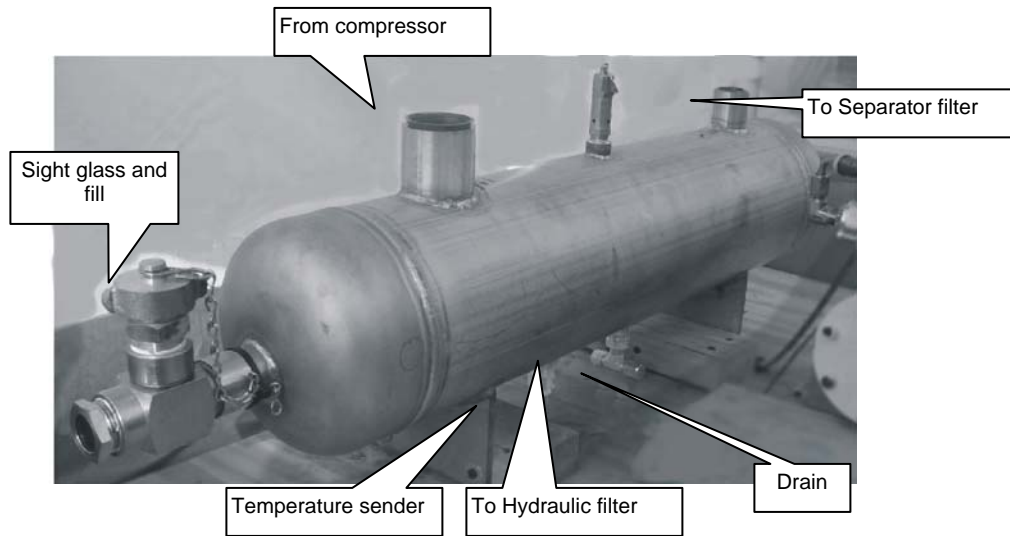

Figure 9 Horizontal sump, inlets and outlets

- Horizontal sump has mounting holes in the legs. Bolt the sump to the pump compartment frame.
- Make sure there is adequate clearance for the fittings and lines under the sump.
- This sump has no optional input or output ports. Connect it as shown here.

III. Oil Fill and Sight Glass

The oil fill and sight glass on the sump may share the same inlet if installed in a wye fitting as shown below, or be installed in separate inlets. Locate these fittings for ease of checking oil level and adding oil to the sump.

If the oil sight glass needs to be extended for visibility, use rigid pipe to ensure that the level displayed is as accurate as possible. The sight glass/oil fill extension must be straight and level.



Figure 10 Oil fill and sight glass in a Wye fitting



Figure 11 Ideal installation, with sight glass and oil fill easy to access



Figure 12 90° Elbow on a sight glass for better visibility



Figure 13 Two elbows on an oil fill cap for accessibility.

F. Oil Temperature Gauge (all sumps)

Mount the gauge on the pump operator's control panel where it will be easy to monitor.

- The gauge connects to the larger of the two prongs on the sender.
- The smaller prong, which is labeled "WK", may be used to activate an oil temperature warning light or alarm (not provided). Waterous recommends installing an over-temperature device.
This prong is one side of a temperature sensitive switch that will close at 250°F. The other side is grounded through the metal of the sump.
The prong can be connected to the negative side of an audible alarm or warning light.
- Follow the installation instructions in the temperature gauge box to connect the sender to the gauge and the warning light.



Temperature sender on Sump

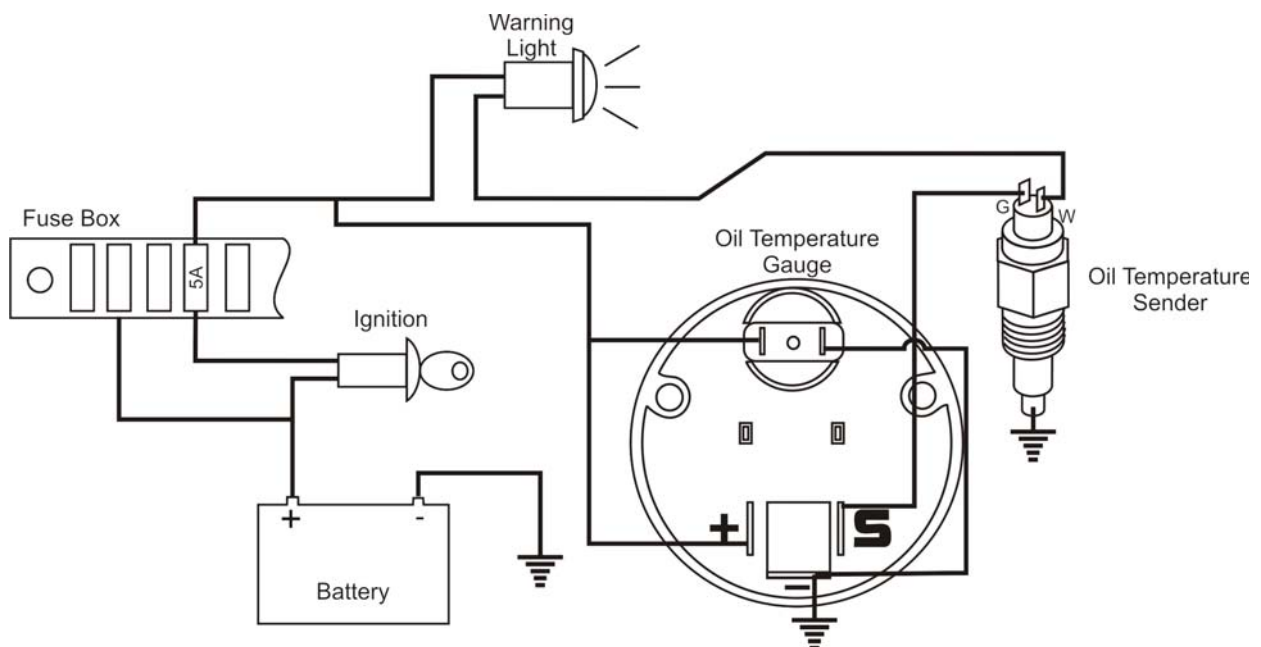

G. Separator Installation

The separator filter can be installed anywhere there is room to securely mount it and run the hydraulic and air lines.

- Install it vertically, with the housing up, the filter element down.
- Make sure there is room to remove and replace the filter element.
- Connect the output to the air manifold, the balance valve, and the fixed/manual regulator on the compressor.

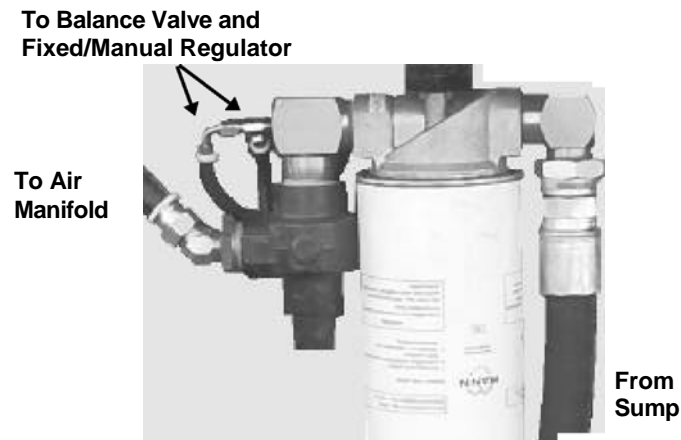

Figure 14 Separator/filter side view with fittings

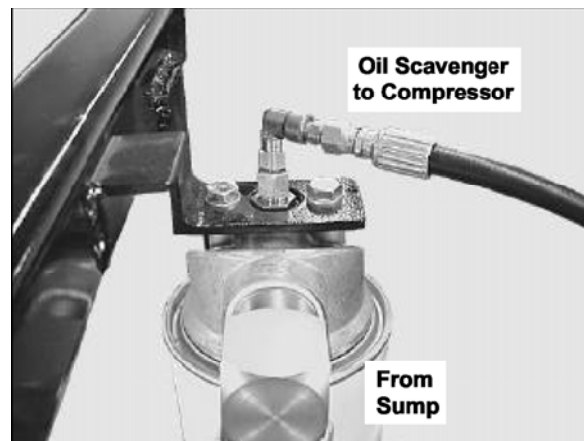
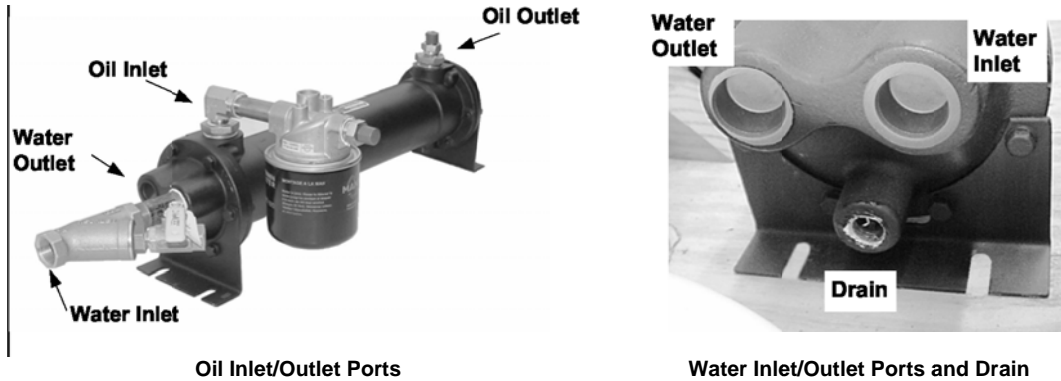

Figure 15 Separator/filter and bracket detail

H. Heat Exchanger Assembly Installation

Caution: Do not install a shutoff valve in the heat exchanger water supply. This will result in system overheat and failure, and void the manufacturer's warranty.

The oil returning to the compressor is cooled by passing it through a water-cooled heat exchanger, usually called the cooler.



- The oil inlet and outlet may be reversed if it makes installation easier.
- The water inlet and outlet may be reversed if it makes installation easier.
- Install the cooler so that it can be drained to prevent freeze damage.

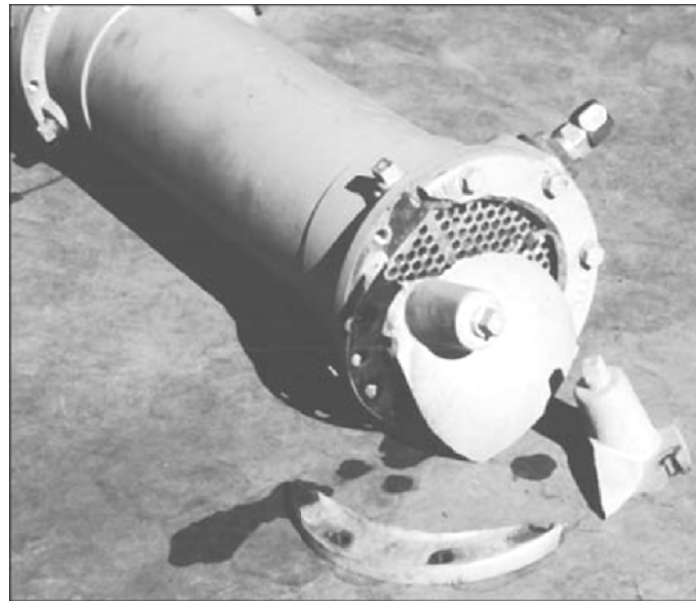

**Freeze damage to undrained cooler,
also showing the small diameter of the water tubes**

- The cooler must be installed horizontally, with the drain at the lowest point, and with a slight slope toward the water drain end.
- The drain hose should be 0.5" I.D. minimum to provide proper drainage.
- The outlet of the drain hose must be lower than the cooler's drain outlet and the drain hose should be a continuous downward run (no goosenecks) to allow proper drainage.

To mount the cooler on the side of a compartment, unbolt the brackets from the ends and reattach them so the cooler can be installed with the drain at the lowest point.

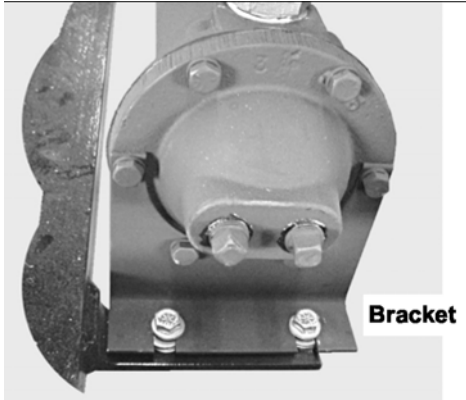

Adjustable Mounting Brackets

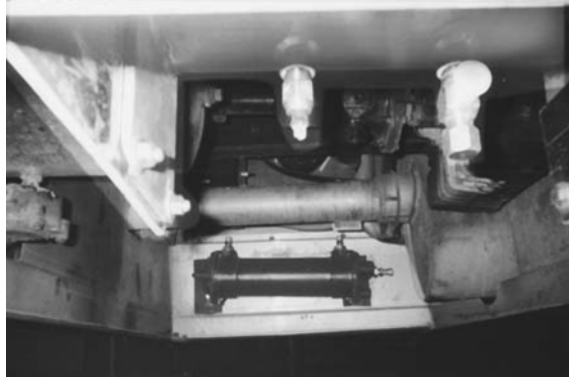

Cooler mounted on the side of a pump compartment, with the cooler body sloping toward the drain for better drainage.

I. Connecting the cooler water lines and wye-strainer

The cooler water is supplied by diverting water through a fitting (OEM supplied) from the discharge side of the fire pump (see page 53 or 54). The cooling water supply hose should be 3/8" I.D. to supply the proper flow for cooling the system. The cooler discharge water may be routed to the booster tank fill tower or returned to the inlet side of the pump, as per the end user's preference.

Normally, coolant water is returned to the booster tank and a check valve is installed in-line to prevent backflow from the tank through the cooler. During drafting and hydrant-supplied operations, the booster tank may overflow because of the cooler water return. If this is objectionable, route the return line to the inlet side of the pump. In this case, it is not necessary to install an in-line check valve, but it will be necessary for the pump operator to open the tank fill valve during operation to prevent overheating the fire pump.

Caution: The Hydraulic filter is a one-way filter. Insure it has been mounted so the oil will flow in the direction indicated by the arrows on the top of the filter.

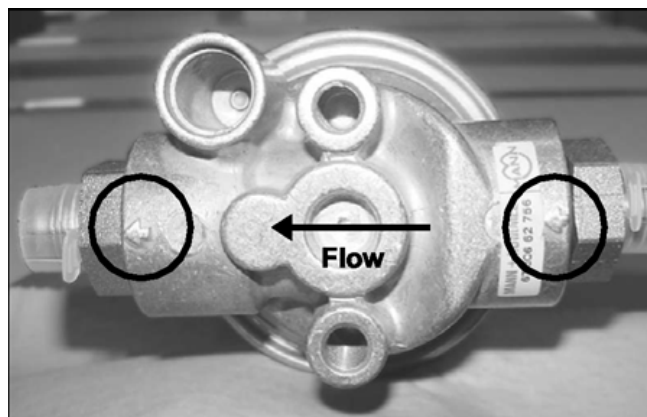

Figure 16 Hydraulic Filter, top, showing flow direction arrows

II. Wye Strainer for Cooler

A wye-strainer is provided to strain water before it enters the cooler's water inlet. The wye strainer requires regular inspection, and should be in an easily accessible location for inspection, removal, and cleaning.

Caution: Waterous is not responsible for damage due to plugged strainers. If the customer's water system contains excessive debris, or the vehicle relies on drafting for its water supply, it may be necessary to install a larger strainer and/or a clean-out valve on the wye-strainer.

Without good water flow through the heat exchanger, the compressor will overheat. Compressor performance will be inadequate, and it may fail completely.

Omitting the Wye-strainer or removing the screen from the Wye does not improve water flow. It will allow debris into the cooler, which can clog the tiny heat exchanger tubes and restrict water flow.



Figure 17 Wye Strainer



Figure 18 Wye-strainer installed, with cleanout valve.

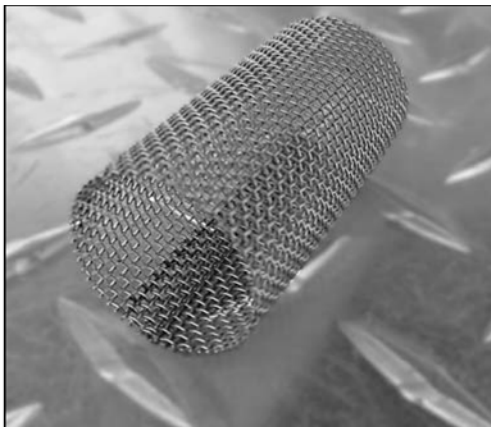

Figure 19 Clean Strainer

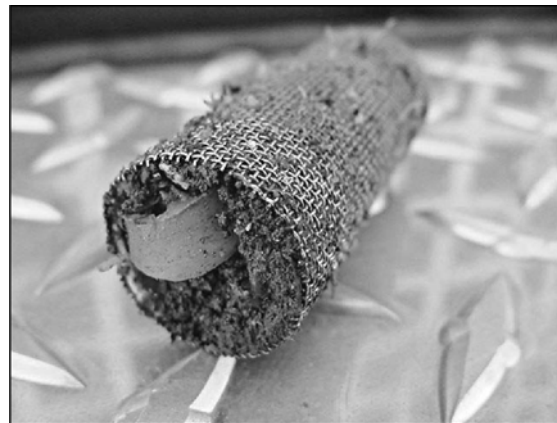

Figure 20 Dirty Strainer

I. Auto-Sync Control System Installation

The Auto-Sync control system electric solenoid valves (systems prior to January 2004, and all SP systems, have manual control valves).

I. Electric Valves (Solenoids)

The solenoid assembly comes on a mounting bracket with the connecting wires and connector already installed.



Electrical Auto Sync Control Switch



Auto Sync solenoid assembly (electric)

1. Install the Auto-Sync control on the pump operator's control panel to run the control wires.

2. Install the Auto-sync control on the pump operator's control panel.
3. Run the control wire from the solenoids to the switch and plug the connectors together.
4. Connect the remaining wire to a +12V supply.
5. Secure the wires to the compartment frame.

Note: If there is excess wire, do not coil it. Coils of wire act as antennas, either receiving or radiating stray EMF signals and interfere with this or other equipment. Bundle the wire harness back on itself, and secure it in a bundle with the folded wires parallel to each other.

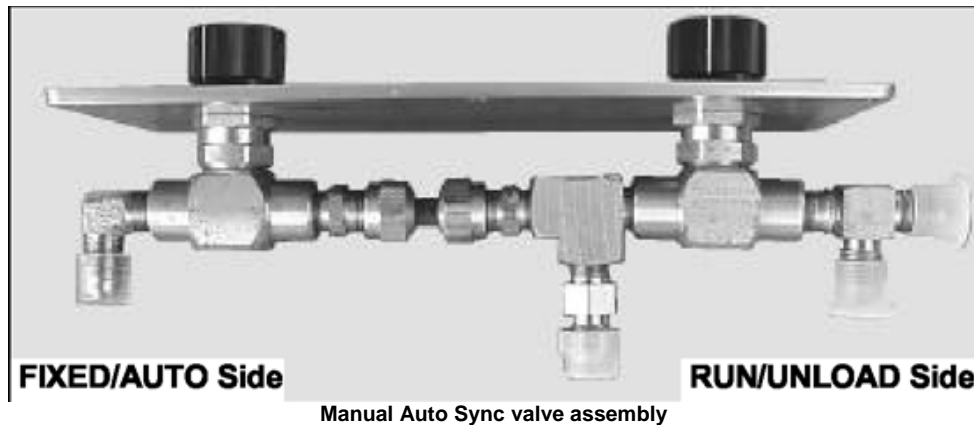

Manual Auto Sync valve assembly



Manual Auto Sync Control

II. Manual

Install the control assembly on the pump control panel.

1. Turn the control knobs to FIXED and RUN.
2. Loosen the setscrews and remove the knobs and nuts from the front of the assembly.
3. Remove the label plate.
4. Use the label as a template for making the holes for the control valves and the mounting bolts, or use the dimensional drawing provided.
5. From the rear, insert the valve stems through the mounting holes.
6. Attach the label to the pump control panel.
7. Replace the nuts and knobs on the front of the assembly, making sure to align the knob indicators to FIXED and RUN.

Make sure the knobs do not bottom out on the label plate. This will prevent the system from working properly.

8. Tighten the setscrews.

J. Balance Valve Installation

Install the Piloted Balance Valve (PBV) so it is accessible for adjusting. Ensure that the water connection is from the discharge side of the pump, and that the valve is correctly oriented, with the water entering the bottom of the valve.

Note: Waterous will not accept responsibility for the performance of any systems with an inaccessible PBV.

Air in from Separator
Filter and
Air out to RUN/UNLOAD
side of Auto Sync Control
Manifold



Air out to
FIXED/AUTO side of
Auto Sync Control
Manifold

Water from discharge
side of Fire Pump

Piloted Balance Valve inlets and outputs, with push-on hoses.

Caution: DO NOT use oil or hose clamps on the Auto-Sync system push-on hoses.

The push-on hose and fittings can be installed more easily if the hose ends are first soaked in hot water with a small amount of dish soap.

Connect the Auto-Sync system air hoses as shown in the Auto-Sync Air Schematic, and connect the water line from the discharge side of the fire pump.

Colored hoses are supplied with the compressor kit, long enough for an average installation, with push-on hose fittings. The schematic is also color coded, which simplifies the installation. Future service issues are easy to resolve as long as the colored hose is used as suggested and supplied.

K. Air Pressure Gauge



Figure 21 Typical Air Pressure Gauge

An air pressure gauge (not included) must be installed

SECTION 3. INITIAL POWER-UP

A. Post-Installation, Pre-Power Up Safety Check

Before you power-up the Waterous system:

1. Remove all tools, shop towels, hose trimmings and other debris from the compartments.
2. Double-check all hydraulic, air, and water lines against the schematics, testing to make sure each connection is tight and that the hose is fully inserted onto the fitting.
3. Check all of the unused inlets. Plastic shipping caps must be removed and replaced with the appropriate plug or cap.
4. Make sure all drain valves are closed.
5. Make sure the gauges are connected to the appropriate sender (temperature, pressure, etc.)
6. Fill the sump with the specified hydraulic oil until the oil level is 1/2 way up the sight glass. You will need to add more oil later, to compensate for oil that remains in the hydraulic lines and the compressor.

Oil used in the system is ISO 68wt hydraulic oil. It must be "Low-foaming" or "Anti-foam".

7. Make sure the foam proportioner is operating properly. (see the manufacturer's installation guide).
8. Make sure the fire pump is operating properly and that water flows through the oil cooler.
9. Make sure the connection between the compressor drive shaft and the PTO is secure and that the driveline angles match.

B. Initial Compressor System Power-up

Warning: Compressed air can be dangerous. Make sure the pressure is allowed to bleed down to atmospheric pressure before opening any connections or valves.

1. Remove the air filter plumbing and pour 8 to 16 ounces of hydraulic oil into the air inlet of the compressor.
2. Replace the air filter plumbing.
3. Place the Auto-Sync system in UNLOAD and AUTO (UNLOAD for electric Auto-Sync)
4. Start the vehicle's engine and engage the PTO.
5. With the system powered up, turn the Auto-Sync to the RUN/FIXED positions (FIXED for electric Auto-Sync). Air pressure should rise to about 110 PSI.
6. Check for leaks by listening for hissing noises at the fittings.
7. Shut the PTO off, allow the pressure to bleed off, and then add oil to the sump to bring the oil level 1/2 way up the sight glass.
8. Proceed to "Adjusting the Auto-Sync Air Balancing System".

SECTION 4. INITIAL ADJUSTMENT OF THE AUTO-SYNC AIR BALANCING SYSTEM

This seldom needs adjusting after the initial setup if the rest of the system is well maintained.

Note: Do not adjust the Auto Sync components to compensate for problems elsewhere in the CAFS system.

Before you make any adjustments, make sure:

- the oil level in the sump is correct,
- the air and oil filters are not overdue for servicing,
- the oil is not overdue for changing,
- the compressor is not overheating,
- the oil cooler strainer is clean,
- the air lines do not have leaks.

Always start by adjusting UNLOAD mode, then FIXED, then AUTO.

A common problem is unauthorized adjustment of the balance valve in an attempt to improve performance.

If unauthorized adjustments to the Auto Sync are a problem we suggest placing a seal over the adjustment points. This will let maintenance personnel know if the system has been tampered with.

A. Electric Auto-Sync Initial Setup

Colored hoses and fittings are supplied with the compressor kit for the average installation. The schematic is color coded to simplify installation. This also makes future service issues easier to resolve, provided suggested hose colors are used.

CAFS retrofit kits and any other system shipped as separate components will need calibrating after installation.

NOTE: Before you make any adjustments, make sure the oil level in the sump is correct, and the air lines do not have leaks or obstructions. Do not adjust the Auto-Sync components to compensate for problems elsewhere in the CAF system.

Always start by adjusting UNLOAD mode, then FIXED, then AUTO.

I. UNLOAD Mode Initial Setting

1. Set the controls on the Auto-Sync control panel to UNLOAD.



Electric Control Panel

2. Close all air discharges.
3. Locate the Air Inlet Trim Valve (AITV), near the air inlet on the compressor.

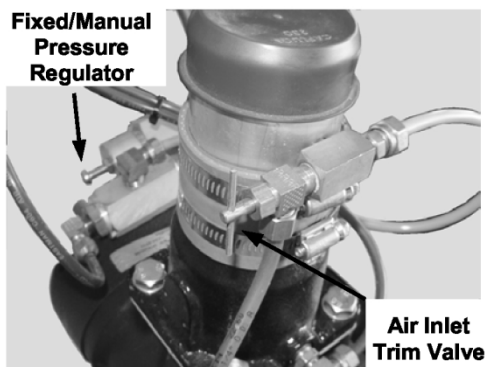

Compressor adjustment points

4. Turn the AITV valve clockwise until it is completely closed, then open it three full turns.
5. Locate the Piloted Balance Valve (PBTV), and turn the needle valve counterclockwise to full open.

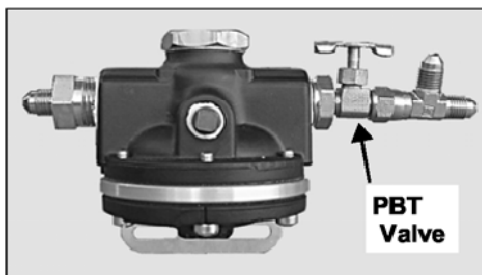

Piloted Balance Trim Valve (PBTV)

6. Start the fire pump, and with the engine at idle, establish water flow through a discharge or tank re-circulation.
7. Engage the PTO.

CAUTION: Do not engage the PTO above 1000 engine RPM

8. With 80-SP systems, the main pressure gauge should read approximately 40 PSI with all discharges closed. Some systems may read lower. This is acceptable.

II. FIXED Mode Initial Setting

The FIXED pressure for a newly installed PTO retrofit kit is about 110 PSI. It must be adjusted to 150 PSI.

1. Locate the Fixed/Manual Pressure Regulator on the compressor and loosen the lock nut on the adjustment screw.
2. Place the controls on the Auto-Sync control panel to FIXED. Wait until the compressor pressure stabilizes.
3. The target operating pressure is 145-150 PSI. Monitor the air pressure reading as you adjust the regulator screw. Give the system several seconds to stabilize between adjustments, and make partial turns of the screw to avoid overshooting the target pressure.
 - Turning the screw IN (CW) will increase pressure.
 - Turning the screw OUT (CCW) will decrease pressure.
4. After the desired fixed pressure is achieved, tighten the lock nut.
5. Verify that the fixed regulator is performing properly by varying the engine speed as you watch the air pressure gauge. The pressure should remain steady at the setting you made. Repeat steps 2 through 4 if needed.
6. Turn the controls to UNLOAD and back to FIXED. The air pressure should rise to the fixed pressure. It may overshoot and drop back to the target pressure, but that is normal.
7. After the FIXED mode is adjusted, proceed to AUTO mode adjustment.

III. AUTO Mode Initial Setting

The pressure for the FIXED mode must have been correctly set before you attempt to adjust the AUTO mode.

1. Make sure the fire pump is operating at 100 PSI at the main discharge, with minimal flow.
2. Place the controls on the Auto-Sync control panel to AUTO.
3. Read the main air pressure and water discharge pressure gauges.
4. The air pressure reading should be equal or up to 5% higher than the water pressure. If the readings are in this range, go to step 7 and verify the operation at other pressures.
5. If the air pressure is not within +5% of the water pressure, adjust it as follows:
 - If the air pressure is too high, turn the AITV clockwise in 1/2 turn increments to close it, checking air and water pressure after each 1/2 turn.

- If the air pressure is too low, turn the AITV counterclockwise 1/2 turn to open it and check pressures. If the air pressure is still too low, open the valve another 1/2 turn and check the pressures again.
 - Do not open the Air Inlet Trim Valve more than this. Use the PBTV if the pressure remains too low.
6. If the air pressure remains too low, close the needle valve on the Piloted Balance Trim Valve (PBTV) one full turn clockwise and check the pressure gauges.

Repeat closing the PBTV one full turn until the air pressure is equal to or up to 5% higher than the water pressure.

If the air pressure is too high after a full-turn of the PBTV, turn the Air Inlet Trim Valve clockwise to lower the pressure until the air pressure is equal to or up to 5% higher than the water pressure.

7. Verify the Auto-Sync system settings by varying the fire pump discharge pressure and monitoring the water and air pressure gauges. The air pressure should rise and fall with the water pressure, matching it within 5%. Pressures should match at static pressure only. It is normal for the pressures to be unmatched when flowing water, air, or solution.

B. Manual Auto-Sync Initial Setup

Air Control circuit is preset and adjusted at the factory prior to shipments. In most cases, the factory settings will provide satisfactory performance for typical CAFS and auxiliary air applications. The FIXED air operation is factory set at 145-150 PSI. The AUTO air operation is set (or trimmed) to match fire pump discharge pressure (+/- 5%).

If the air control circuit requires changing or the circuit has lost its factory setting, the following procedure can be used to "fine tune" the system.



Figure 22 Manual Control Panel

I. UNLOAD Mode Initial Setting

1. Preset the Inlet Air Trim Valve (IATV) by closing the valve, then opening it 3 turns.
2. Preset the Piloted Balance Trim Valve (PBTV) to full open.

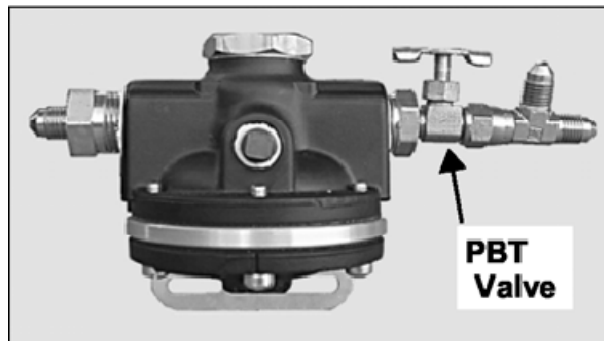
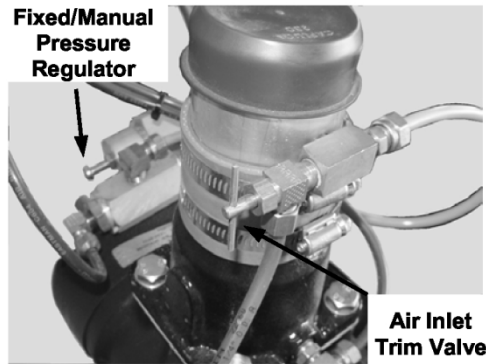

Figure 23 Piloted Balance Trim Valve (PBTV)

3. Start the fire pump and, at idle, establish water flow either through a discharge or tank recirculation.
4. The Auto-Sync Control Panel should be in the FIXED/UNLOAD mode and all air discharges closed.
5. Start the air compressor by placing the compressor engage switch to "ON."



Compressor adjustment points

6. The main air pressure gauge should read 40-50 PSI. In the UNLOAD mode, this minimum pressure is always present to provide compressor oil circulation.

We are ready to proceed with final adjustments for the FIXED and AUTO modes.

II. FIXED Air Initial Setting:

1. To set the pressure for the FIXED operation, first locate the "Fixed Pressure Regulator." The regulator has an adjustment screw with lock nut.
2. Loosen the regulator's lock nut.
3. Go to the Auto-Sync Panel and place controls to the FIXED/UNLOAD positions. The compressor will build pressure to some valve and hold (regulate).
4. While monitoring the air pressure gauge, adjust the screw on the Fixed Pressure Regulator until the desired pressure is reached. Turning the screw IN will INCREASE pressure and turning the screw OUT will DECREASE pressure.
5. Once the desired regulated pressure is achieved, tighten down the lock nut.
6. Verify the fixed regulator is performing by varying the compressor speed and monitoring the air pressure gauge. The pressure should remain steady at your fixed pressure setting.

With the final adjustments to the FIXED air mode complete, proceed with setting the AUTO air mode.

III. AUTO Air Initial Setting:

1. With the fire pump operating at 100 PSI main discharge and minimum flow, place the Auto-Sync controls to the AUTO/RUN position.
2. Monitor main water discharge pressure gauge and the air pressure gauge. The pressure readings should be the same. If not, proceed to step 3.
3. The Inlet Air Trim Valve (IATV) is the first valve to adjust.
 - a. If the air pressure is too high, close the trim valve in half turn increments, monitoring both water and air pressure gauges, until the pressures match. Once the pressures match, no further adjustments are needed, proceed to step 5.
 - b. If the air pressure is too low, open the trim valve a half turn, then check water and air pressure gauges.

- c. If the air pressure is still too low, open the trim valve another half turn. If air pressures match, no further adjustments are needed, proceed to step 5.
 - d. If air pressure is still too low, proceed to step 4.
4. The Inlet Air Trim Valve (IATV) is now four turns open from fully closed. It is not desirable to have the trim valve open more than four turns. In order to extend its range, go to the Piloted Balance Trim Valve (PBTV).
 - a. From the fully open position, close the PBTV one turn then check water and air pressure gauges.
 - b. If air is still too low, close the PBTV one additional turn and check gauges.
 - c. Keep repeating this process until air pressure matches or is slightly higher than water pressure.
 - d. The final adjustment can be done using the IATV and step 4.
5. Verify the piloted balance valve is performing by varying the fire pump discharge pressure and monitoring the water and air pressure gauges. The air pressure should follow the water pressure and match it. If not, repeat the final adjustment procedure.
6. If the air pressure remains too low, close the needle valve on the Piloted Balance Trim Valve (PBTV) one full turn clockwise and check the pressure gauges.
7. Repeat closing the PBTV one full turn until the air pressure is equal to or up to 5% higher than the water pressure.
8. If the air pressure is too high after a full-turn of the PBTV, turn the Air Inlet Trim Valve clockwise to lower the pressure until the air pressure is equal to or up to 5% higher than the water pressure.
9. Verify the Auto-Sync system settings by varying the fire pump discharge pressure and monitoring the water and air pressure gauges. The air pressure should rise and fall with the water pressure, matching it within 5%. Pressures should match at static pressure only. It is normal for the pressures to be unmatched when flowing water, air, or solution.

SECTION 5. SUGGESTED THIRD-PARTY COMPONENTS

Note: These are guidelines useful for many installations, but selection of third-party components is at the discretion of the system installer or vehicle manufacturer.

A. Suggested components for CAFS discharges:

The installer must provide fittings and tubing to connect the CAFS components to the vehicle's discharge outlets. These are suggested parts for the common discharge sizes. If the planned discharge system is not covered in this guideline, please contact Waterous.

Note: Waterous strongly suggests that every CAFS discharge have an air check valve and a water check valve, as shown below.

The air check valve prevents foam solution from back flowing into the compressor and contaminating the oil. The water check valve isolates the discharge, preventing CAF from back flowing into the foam solution manifold and exiting through another discharge.

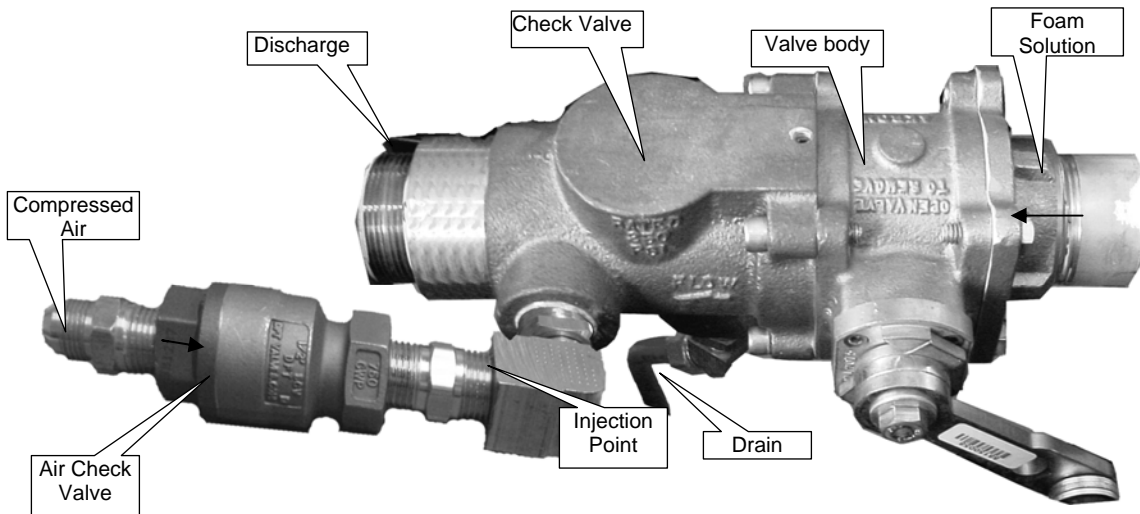

Figure 24 Typical CAFS Discharge

B. Suggested Hose

The inside diameter (I.D.) of the hose is the most important factor, and any hose with the correct I.D. and rated to withstand the expected air system pressures (500 PSIG burst pressure) may be used.

I. Push-on

We have found the most cost-effective hose is the push-on type hose. H101 or H201 general-purpose hose has an acceptable working pressure. Gates, Dayco, Parker, Weatherhead and Aeroquip brands will suffice. All of these hoses come in a variety of colors for color-coding the lines by purpose.

Discharge:	Suggested:
1" booster reel or 1" remote	Use 3/8" ID air hose.
1.5" and 2"	Use 1/2" ID air hose
2-1/2"	Use 3/4" ID air hose
Auxiliary Air Outlet	Use 3/8" ID air hose

II. Air Brake

Air brake tubing may also be used provided strict attention is paid to the inside diameters:

Size	Working PSI	Burst PSI
.375" OD is .250" ID	150	1400
.500" OD is .375" ID	150	950
.625" OD is .500" ID	150	900
.750" OD is .625" ID	150	800

Discharge fittings and Kits: Lists are available on request for various discharges.

III. Hydraulic

For the hydraulic portion of the compressor system, it is necessary to use SAE 100R1 or SAE 100R5 as a minimum. Hose sizes necessary for installation are:

#4 for the scavenger from the separator filter to compressor.

#8 for the oil inject and cooler circuit.

#24 for the air out of the sump to the separator filter assembly.

C. Power take-off suggestions

There are many PTO suppliers and many types of transmissions available, and the choice of PTO will in part depend on what can be installed in the vehicle. "Hot Shift" PTOs are commonly used.

Make sure that there will be room to install the air compressor on a bracket close to the PTO, with their drive angles matched.

Caution: The driveline angles **MUST** be matched to prevent serious damage to the compressor, PTO, or transmission.

Specific gear ratios vary among the different transmissions and PTO suppliers. The ratios suggested below are a guide for selecting the PTO. With these ratios, the rated CFM is usually achieved with the engine speed near 1400 RPM.

Caution: A higher speed on the PTO means the CAFS system will reach the desired CFM at lower engine speeds. Exceeding the compressor's rated RPM can damage the compressor, and void the warranty. In such applications, an over speed cut-out should be installed on the PTO to protect the compressor.

To calculate the possible compressor RPM, use this equation:

Engine RPM x gear ratio on PTO x 3.64 = compressor RPM

The compressor is rated for a maximum of 10000 RPM on the compressor rotor at a pump rate of 80 CFM. The rated CFM is usually achieved with the engine speed near 8700 RPM.

CFM required	PTO speed	HP average
60-80	180% HI	25

SECTION 6. TROUBLESHOOTING GUIDE

A. Troubleshooting - CAFS

Observed Symptom	Probable Cause	Suggested Remedy
Lack of air pressure from compressor	Lack of air supply to clutch (for air-clutch systems)	Repair air leak or re-establish air supply
Compressor not engaging	No PTO engagement	Confirm OK TO PUMP light is on, if not check wiring for damage or disconnected wire, check PTO.
Compressor engaging. No air supply to discharges or insufficient air supply.	Auto-Sync switches not in correct position.	Confirm 40 PSI in UNLOAD position (200 CFM systems) and 50+ in run position. Smaller compressors have lower UNLOAD pressures. Verify when in FIXED/RUN whether pressure reflects 145-150 PSI
	(electric valves) Verify there is power to the air solenoid and check operation of solenoid.	Air discharge solenoid not working. Repair/replace solenoid Air solenoid working - leak between solenoid and discharge. Repair leak.
	Air check valve defective	Replace or correct installation.
	Trim valve out of adjustment	Refer to trim valve instructions
	Restricted minimum pressure valve	Clean rust or debris from valve
	Air plumbed before discharge valve seal	Relocate to discharge side of discharge valve
	Incorrect air line size	Size according to discharge and replace line with correct size.
System functioning correctly, pressure gauge reading obviously incorrect.	Gauge malfunction, air line detached	Check for air leaks, replace gauge
FIXED has pressure but AUTO has no pressure	No water supply to balance valve.	Check line for proper installation, with no kinks or obstructions. Refer to trim valve instructions.
Air discharge pressure too high	Red hose circuit (compressed air control) has leak or is disconnected.	Repair leak or attach hose
System overheating	Inadequate water flow through cooler	Ensure adequate water flow through pump. Check Y strainer for obstruction, clean and reinstall Drain and flush cooler water tubes

Observed Symptom	Probable Cause	Suggested Remedy
	Adequate water flow through cooler.	On-board tank used for cooling for a prolonged period - water too hot to effectively cool the compressor. Locate source of lower temperature water. Check oil level - Adjust level to half of the sight glass on level surface.
	Low compressor oil level:	Check the hydraulic lines for kinks Change oil filters
	Temperature sending unit and or gauge circuit malfunction.	Check wire connections at sending unit
High Oil Consumption	Overfull compressor oil	Adjust level to half of the sight glass on level surface.
	Excess of 200 CFM air flow (on 200 CFM systems)	Back down RPM's and flow CAFS to relieve pressure, then recheck Replace Air/Oil Separator Filter
	Air/oil Separator Filter torn or damaged (could be caused by air flow of higher than 200CFM)	System being operated at higher than capacity
"Excessive" compressor bleed down time on shutoff	Systems vary in bleed down time.	If Auto-Sync is operating correctly, and compressor output is within spec, do nothing.
Engine stalls upon compressor engagement	Engaging compressor while under load	Allow compressor to bleed down before re-engagement
	Running system without flowing air causes oil to accumulate in compressor acting like hydraulic pump	Bleed down air, restart compressor, and move air
	Underrated engine horsepower	Raise engine RPM
	Auto-Sync in FIXED / RUN setting	Engage in AUTO/UNLOAD, then switch to FIXED/RUN
	High oil level	Check oil level, adjust level to half of the sight glass with vehicle parked on a level surface
	Compressor locked up	Repair/replace compressor

Compressor locked up	High oil level (compressor is flooded)	Check oil level, adjust level to half of the sight glass with vehicle parked on a level surface
	Sump fire	Check system and repair
	Low oil level or no oil	Check system and repair
Air flow meter stuck at "0" CFM	Magnet uncoupled in meter	Turn air flow on and off to re-couple

Observed Symptom	Probable Cause	Suggested Remedy
Air flow meter stuck at high CFM		Move large amounts of air out discharge and turn air flow on and off to re-couple
Poor foam (wet or dry) or no foam (assuming air pressure to discharges is OK)	Using wetting agent and not foam concentrate.	Use foam concentrate
	Foam proportioning control turned too low.	Increase amount of concentrate delivered to manufacturer recommended amount.
	Foam proportioning control OFF or turned too low, foam tank empty.	Make sure proportioner is turned on, foam supply valve is open, foam tank has concentrate, Y strainer is clean, and supply line is connected to injector.
Discharge hose shaking (slug flow)	Foam proportioner ON, setting correct, and tank has foam concentrate, but not providing foam solution.	Refer to foam proportioner manufacturer's instructions for detailed calibration and troubleshooting instructions
Foam in the water system (when proportioner turned off)	Foam concentrate was poured into the on-board water tank	Flush tank and pump with clean water, refill
	Foam manifold drain lines not isolated from water drain lines	Isolate to separate drain valve
	Cooler line plumbed from foam manifold	Relocate line to discharge side of pump
	Foam manifold check valve defective	Rebuild/replace check valve
Water in compressor oil/air	Leaking inside cooler Freeze damage	Isolate cooler and check for leaks, replace if needed, check drain
	Defective air check valves	Replace or check
	Missing air check valves for discharges	Install check valves

Clutch smoking	Engaging in RUN position	Engage in AUTO/UNLOAD only
	Slight air leak from solenoid to clutch	Repair air leak
	High RPM engagement	Engage in lower RPM
	Not allowing compressor to bleed down before engaging clutch again	Allow for bleed down
	Contaminated clutch disc	Clean or replace

Observed Symptom	Probable Cause	Suggested Remedy
Safety pop off valve opening at low pressure	Auto-Sync system out of balance	Adjust the Auto-Sync system, making sure to not open the trim valve on the compressor more than 3 turns.
	Sump fire damaged pop off valve	Check system for other damage and replace valve
Safety pop off valve repeatedly opening	Trim valve or inlet completely open	Refer to trim valve instructions

SECTION 7. DRAWINGS

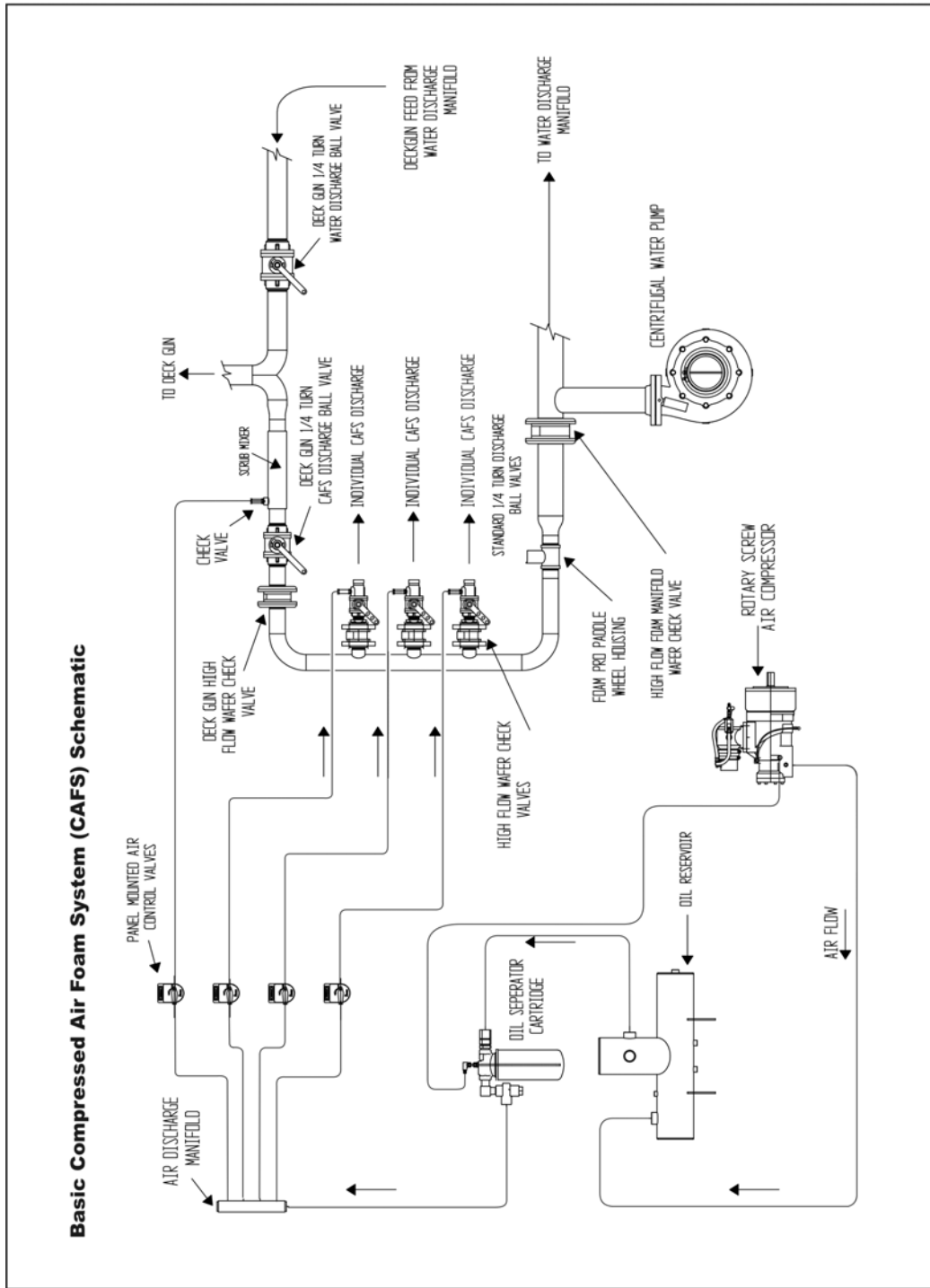
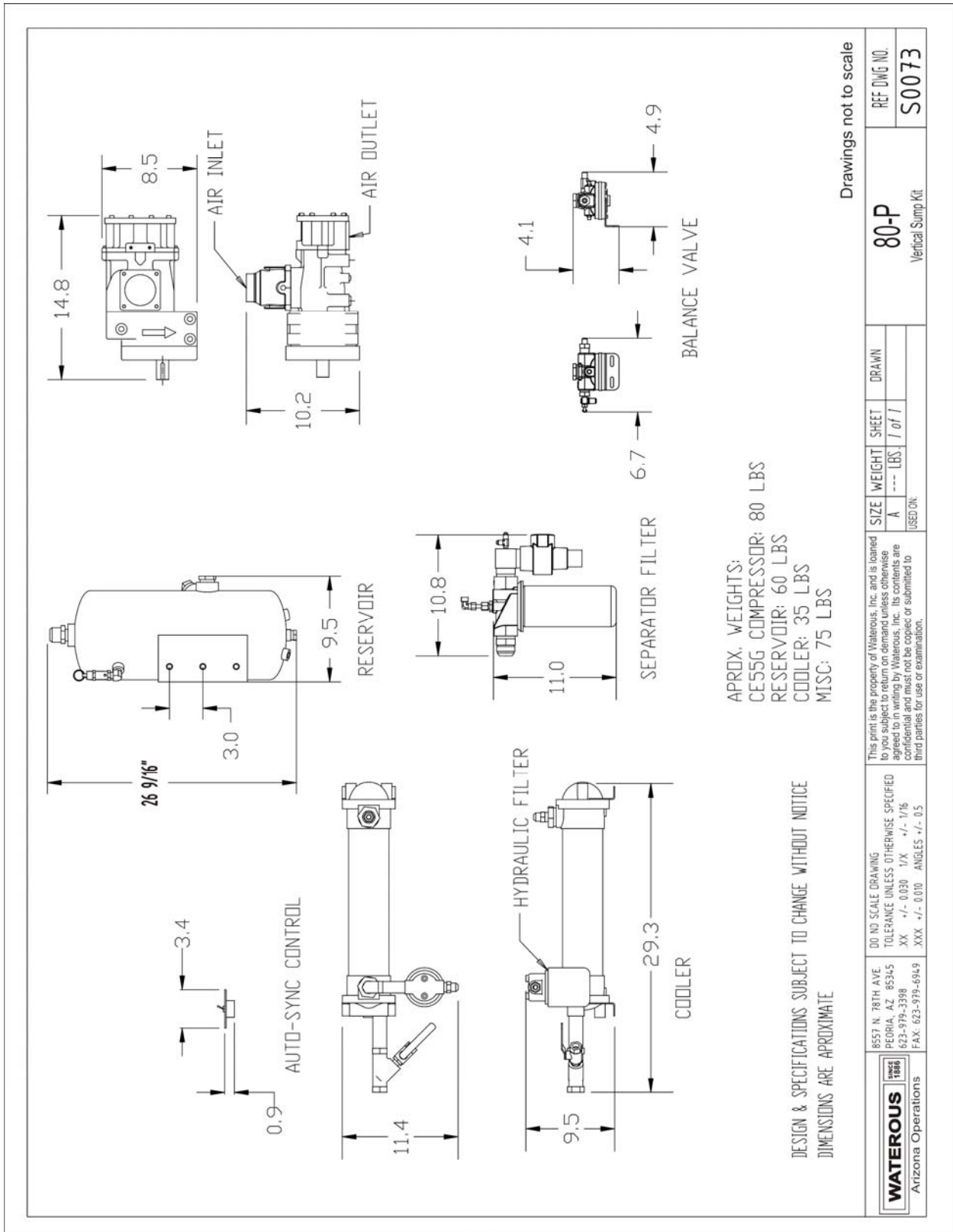

Figure 25 Basic CAFS Schematic



WATEROUS Arizona Operations 8557 N. 78TH AVE PEDRIA, AZ 85345 623-979-3398 FAX: 623-979-6949	DO NOT SCALE DRAWING TOLERANCE UNLESS OTHERWISE SPECIFIED XX +/- 0.030 1/16 +/- 1/16 XXX +/- 0.010 ANGLES +/- 0.5	This print is the property of Waterous, Inc. and is loaned to you subject to return on demand unless otherwise agreed to in writing by Waterous, Inc. Its contents are confidential and must not be copied or submitted to third parties for use or examination.	SIZE A	WEIGHT --- LBS.	SHEET / of /	DRAWN	REF DWG NO. 80-P Vertical Sump Kit
	USED ON:						

Figure 26 80-P Vertical Sump Kit

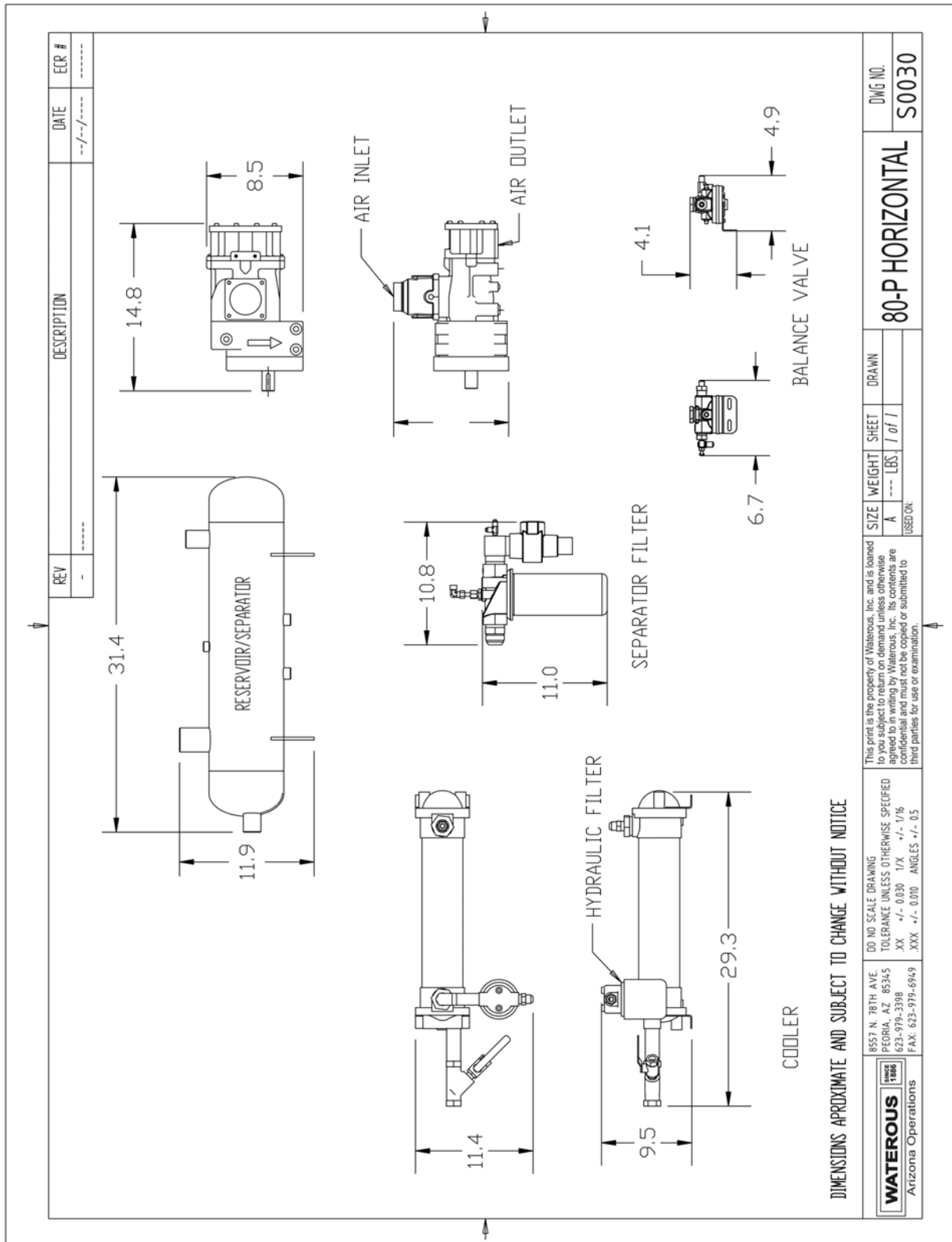

Figure 27 Horizontal Sump Kit (Optional)

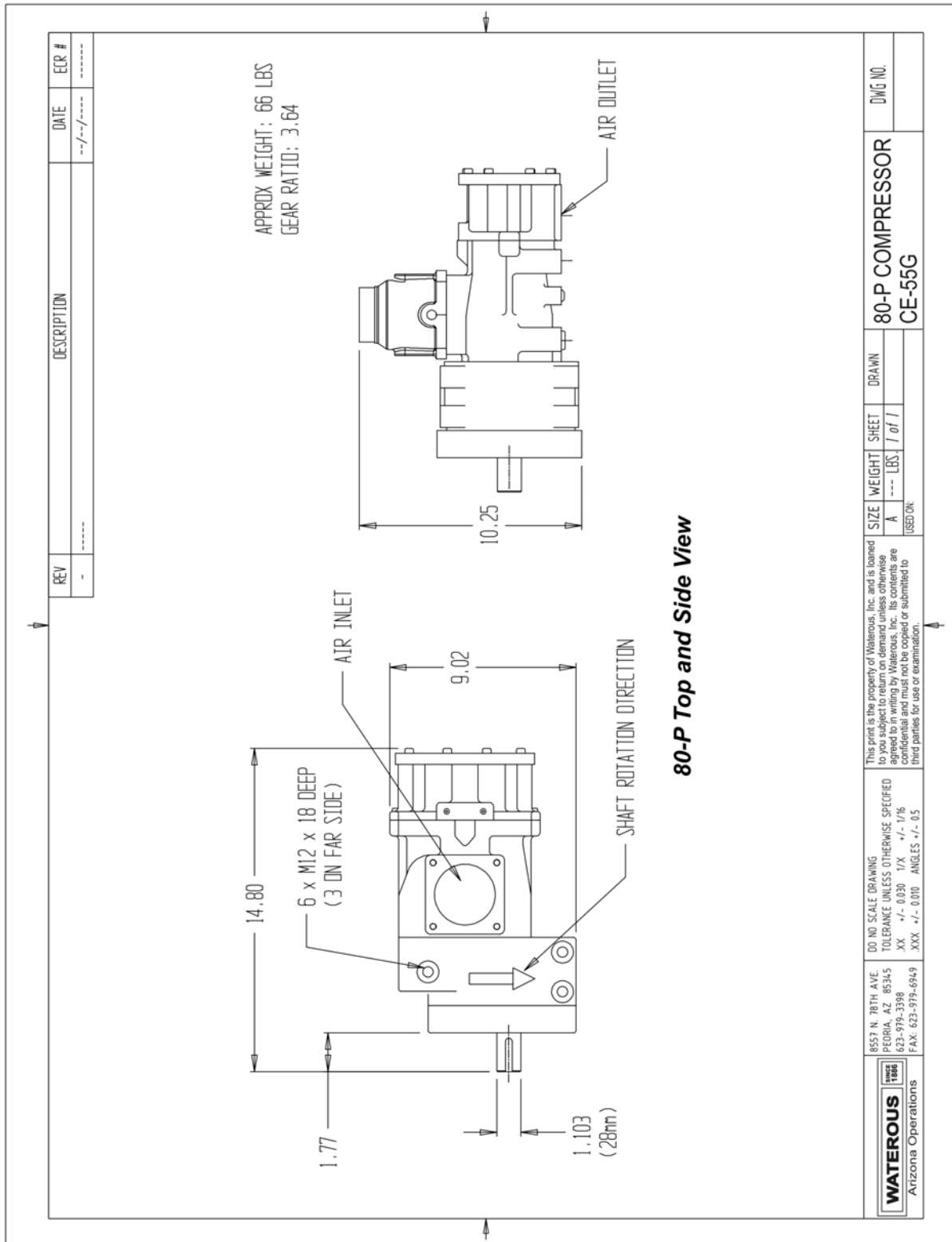

Figure 28 Compressor Dimensions

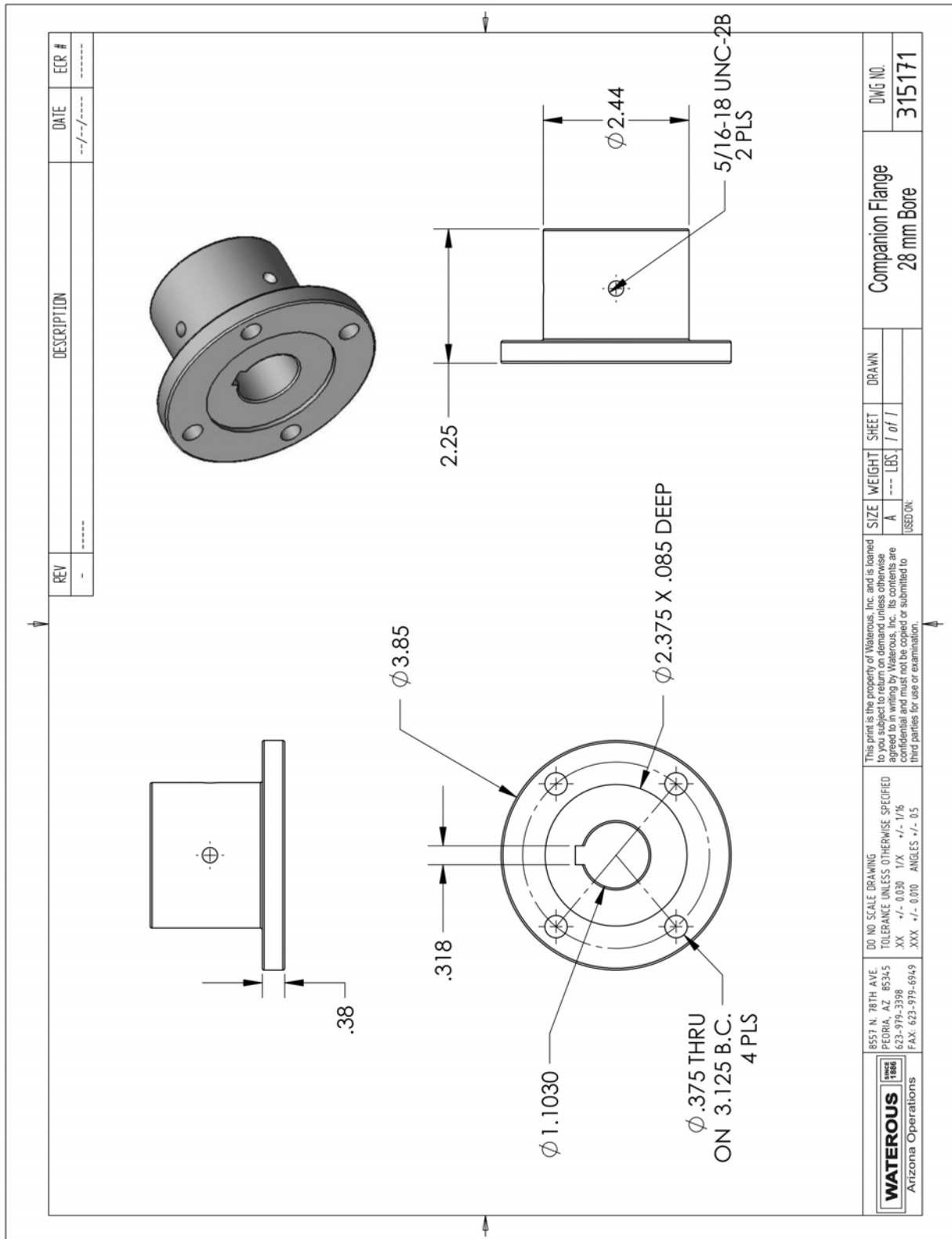
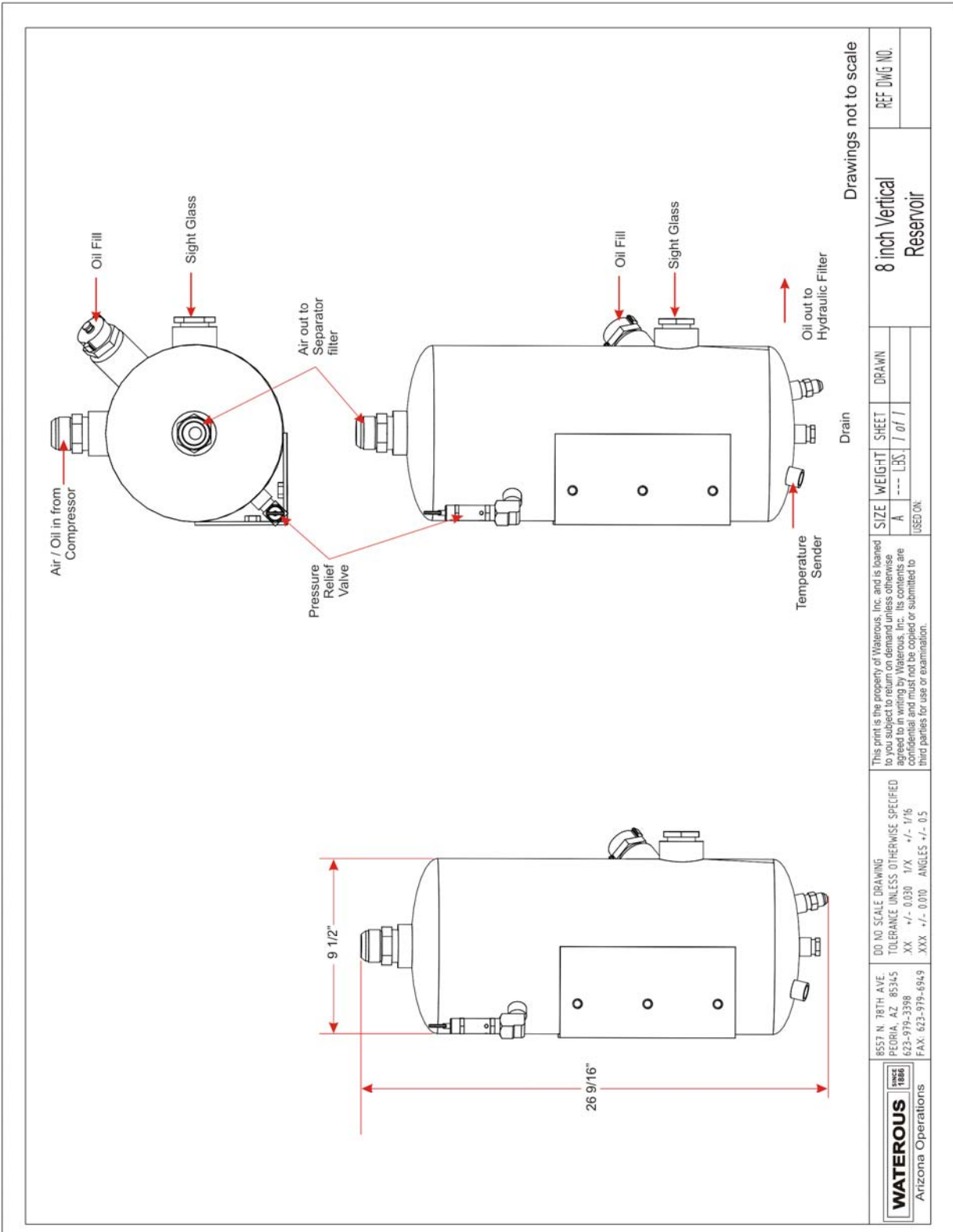
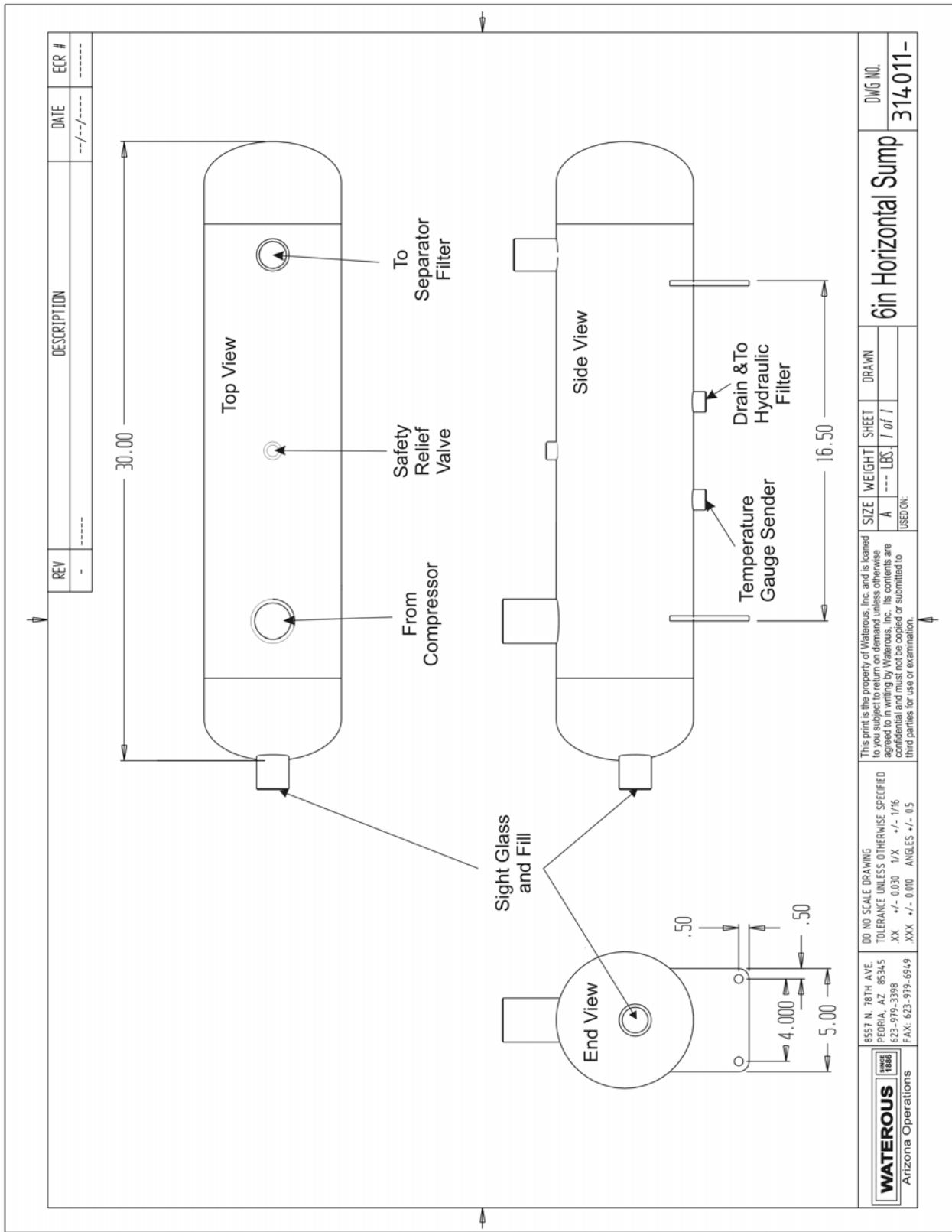

Figure 29 Companion Flange, 28mm Bore

 WATEROUS Arizona Operations	8557 N. 78TH AVE. PECORIA, AZ 85345 623-979-3398 FAX: 623-979-6949	DO NOT SCALE DRAWING TOLERANCE UNLESS OTHERWISE SPECIFIED XX +/- 0.030 1/X +/- 1/16 XXX +/- 0.010 ANGLES +/- 0.5	This print is the property of Waterous, Inc. and is loaned to the user for their use only. All contents are confidential and must not be copied or submitted to third parties for use or examination.	SIZE A WEIGHT --- LBS. SHEET 1 of 1	DRAWN COMPANION FLANGE 28 mm Bore	DWG NO. 315171
	REV - DESCRIPTION DATE --/--/---- ECR # -----					



Figure



31 Horizontal 6" Sump (Optional)

Figure

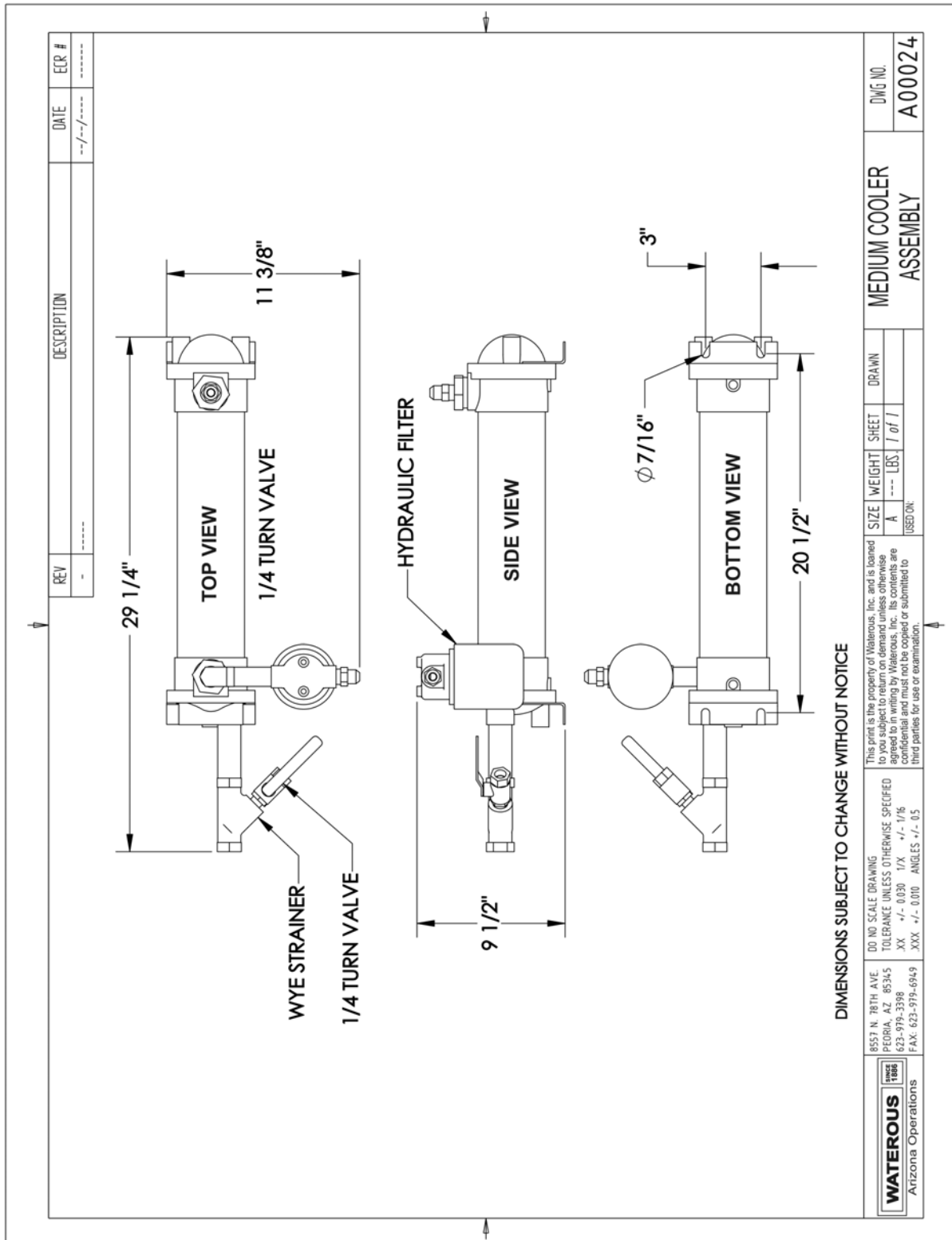

Figure 32 Cooler and Hydraulic Filter Assembly

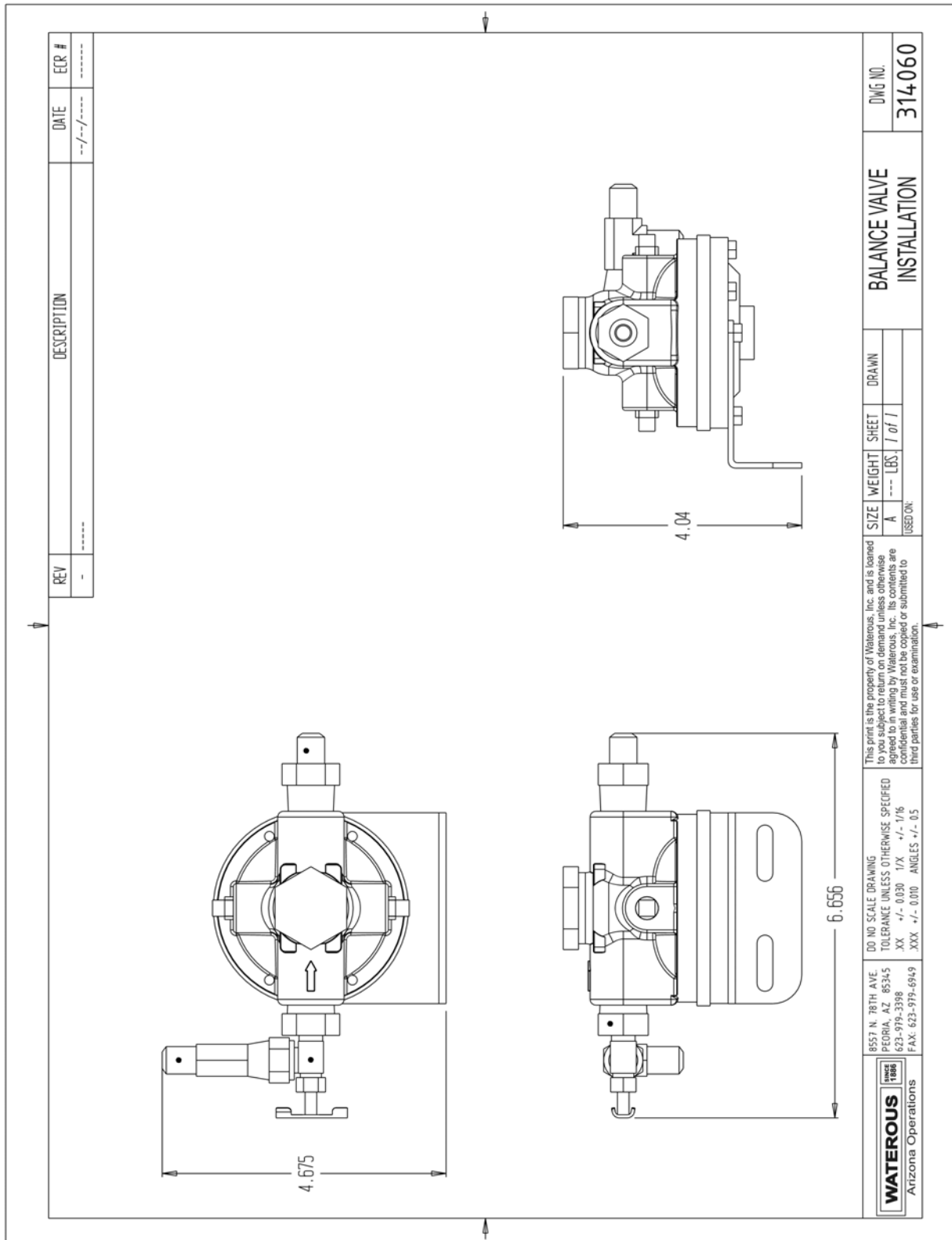
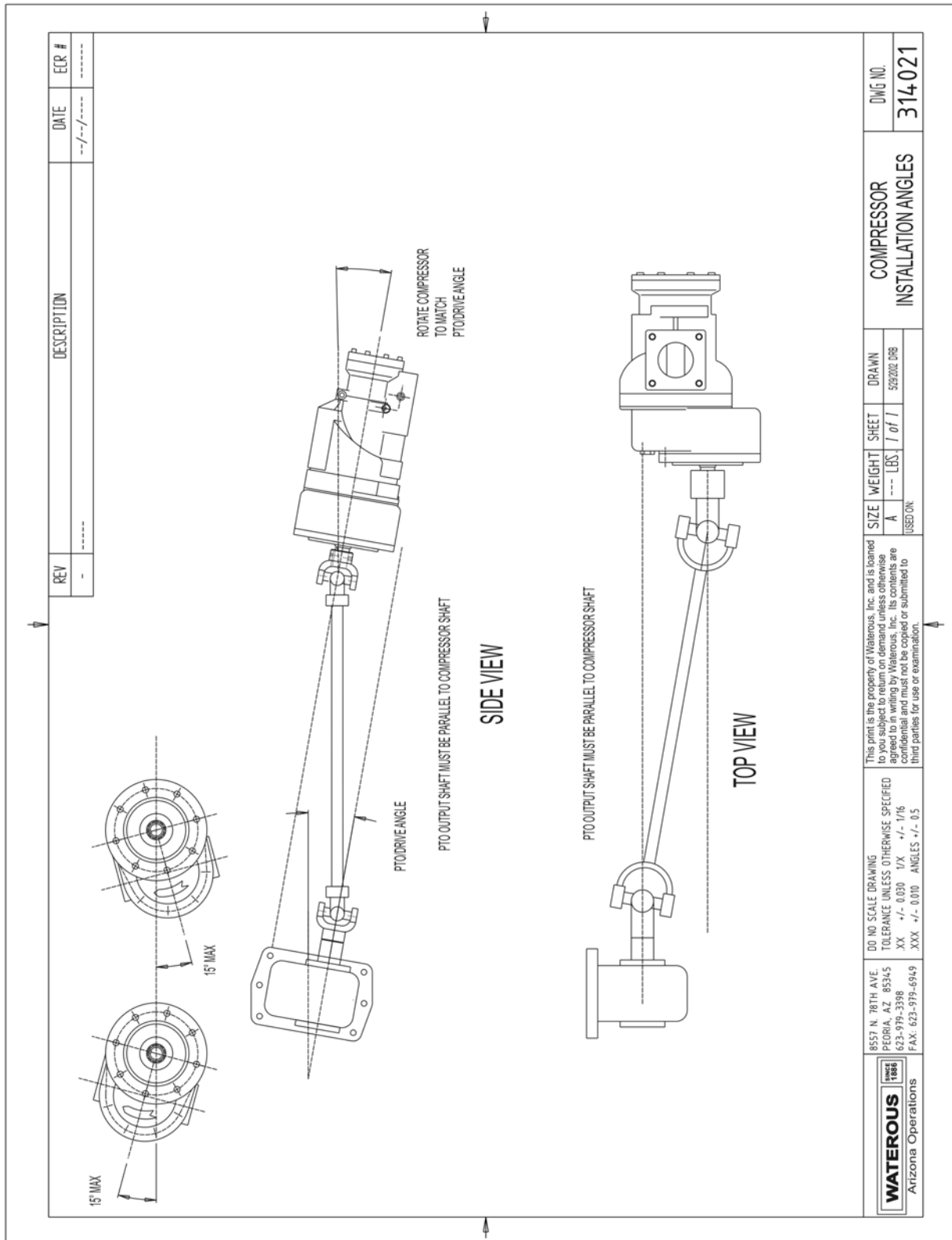

Figure 33 Piloted Balance Trim Valve (PBTV)



WATEROUS Arizona Operations	8557 N. 78TH AVE. PEORIA, AZ 85345 623-979-3398 FAX: 623-979-6949	DO NO SCALE DRAWING TOLERANCE UNLESS OTHERWISE SPECIFIED XX +/- 0.030 1/8 +/- 1/16 XXX +/- 0.010 ANGLES +/- 0.5	This print is the property of Waterous, Inc. and is loaned to you for your use only. It is not to be reproduced, copied, or used in any way without the written consent of Waterous, Inc. Its contents are confidential and must not be copied or submitted to third parties for use or examination.
USED	SIZE A	WEIGHT --- LBS.	SHEET / of /
		DRAWN 529202 P08	DWG. NO. 314021

Figure 34 Compressor Installation Angles

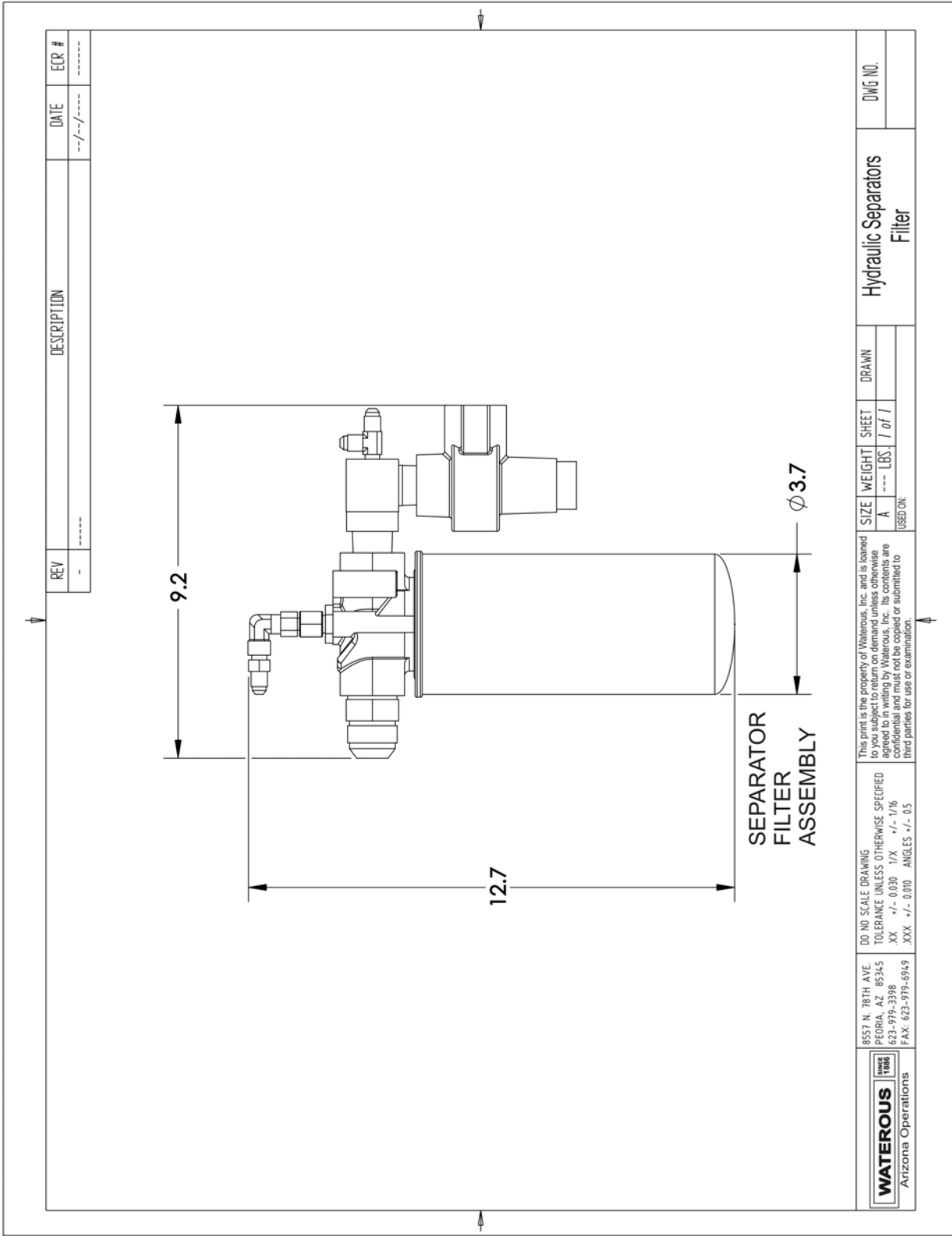

Figure 35 Separator Filter Assembly

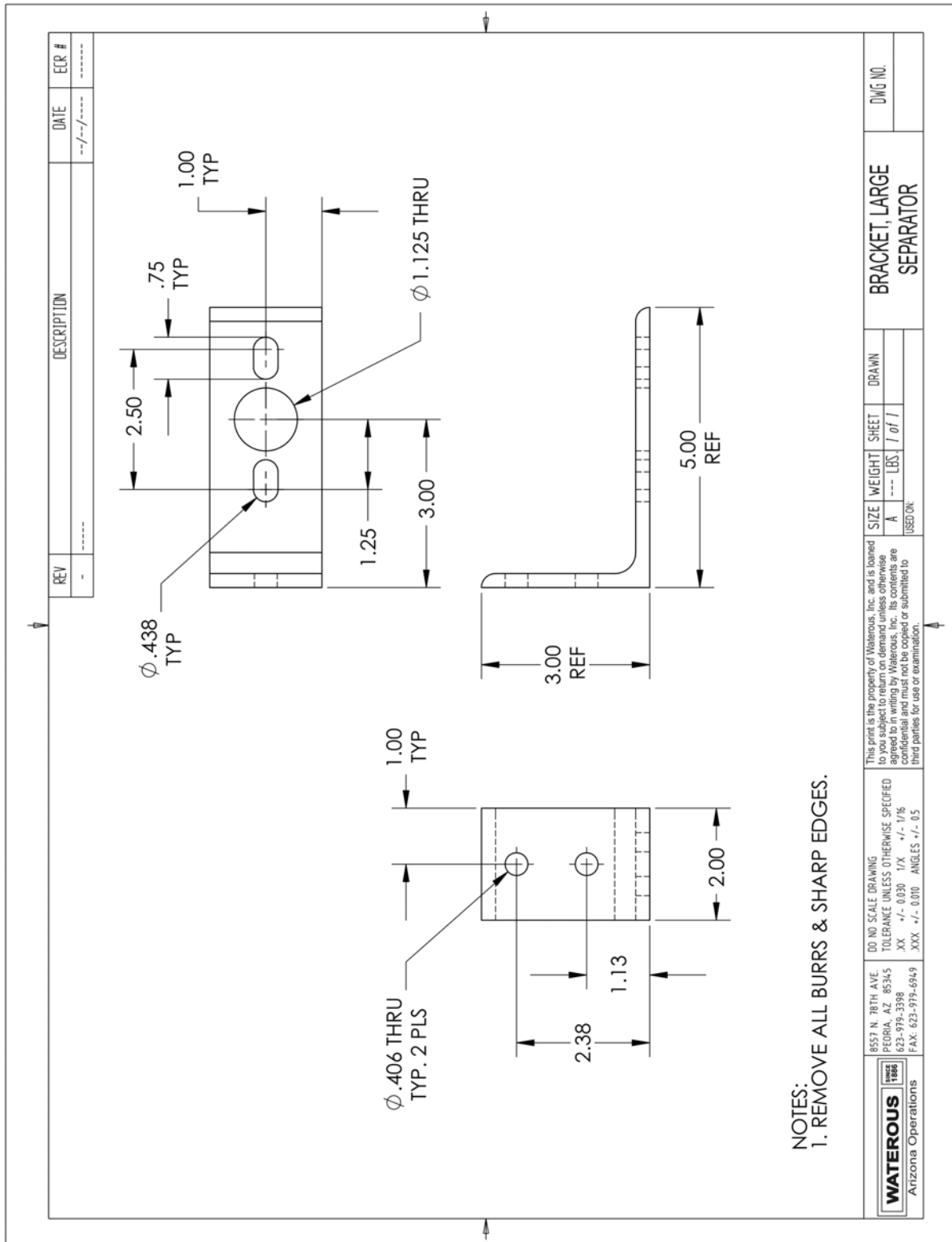

Figure 36 Separator Bracket

WATEROUS Arizona Operations	8557 N. 78TH AVE. PEORIA, AZ 85345 623-979-3398 FAX: 623-979-6949	DD: NO SCALE DRAWING TOLERANCE UNLESS OTHERWISE SPECIFIED XX +/- 0.030 1/X +/- 1/16 .XXX +/- 0.010 ANGLES +/- 0.5	This print is the property of Waterous, Inc. and is loaned to you subject to return on demand unless otherwise agreed to in writing by Waterous, Inc. Its contents are confidential and must not be copied or submitted to third parties for use or examination.	SIZE A	WEIGHT --- LBS	SHEET 1 of 1	DRAWN	BRACKET, LARGE SEPARATOR	DWG NO.

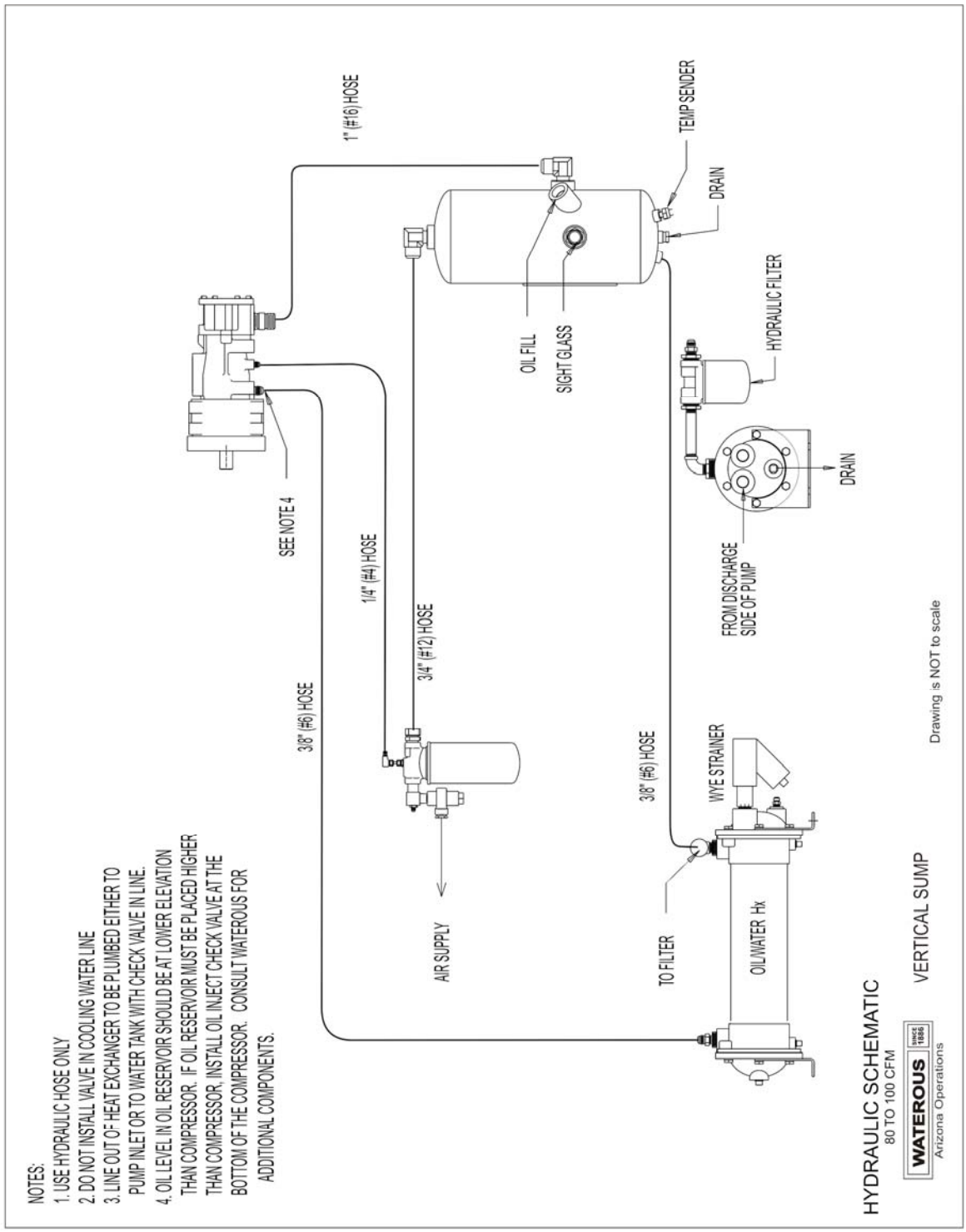

Figure 37 Hydraulic Schematic, Vertical Sump

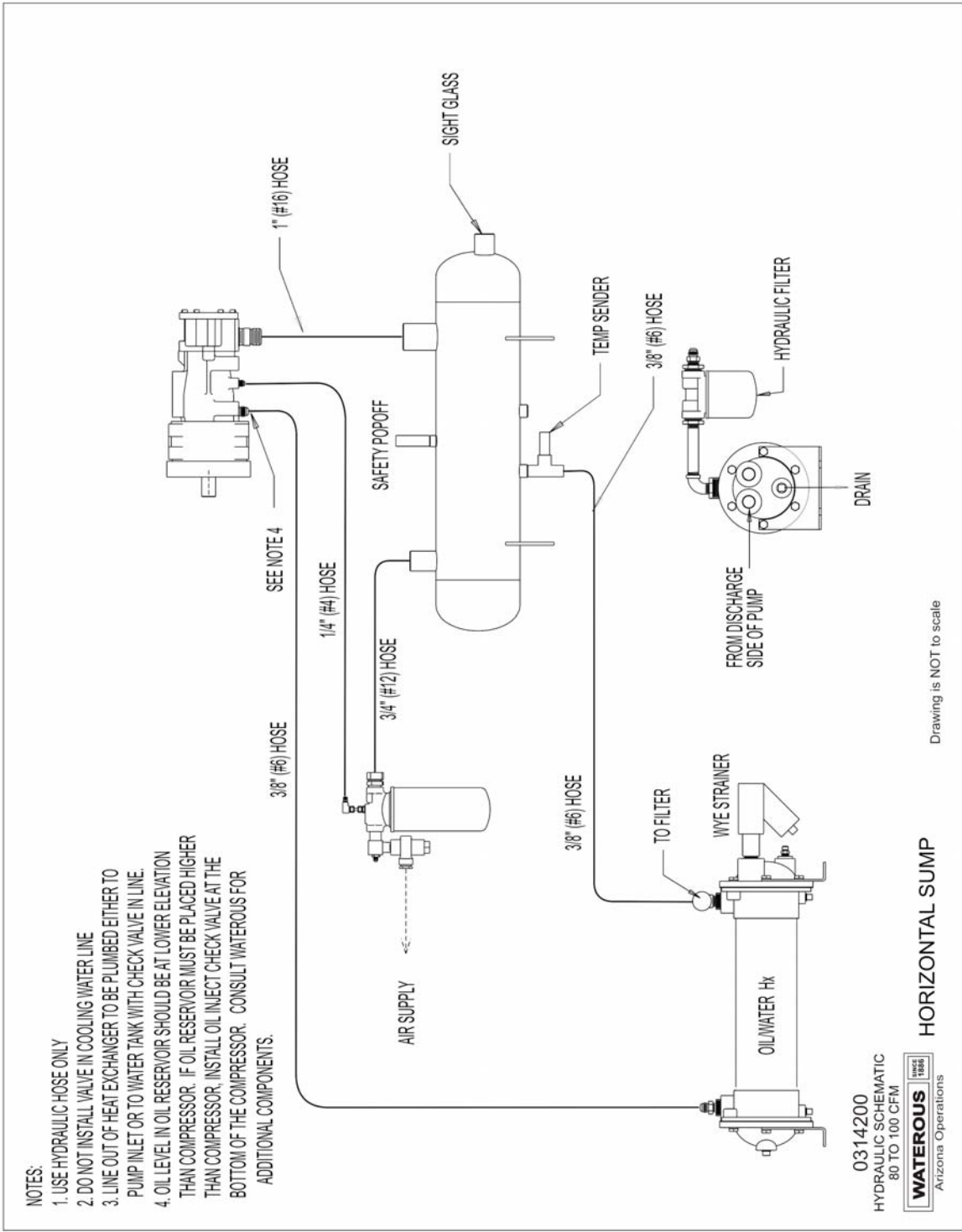
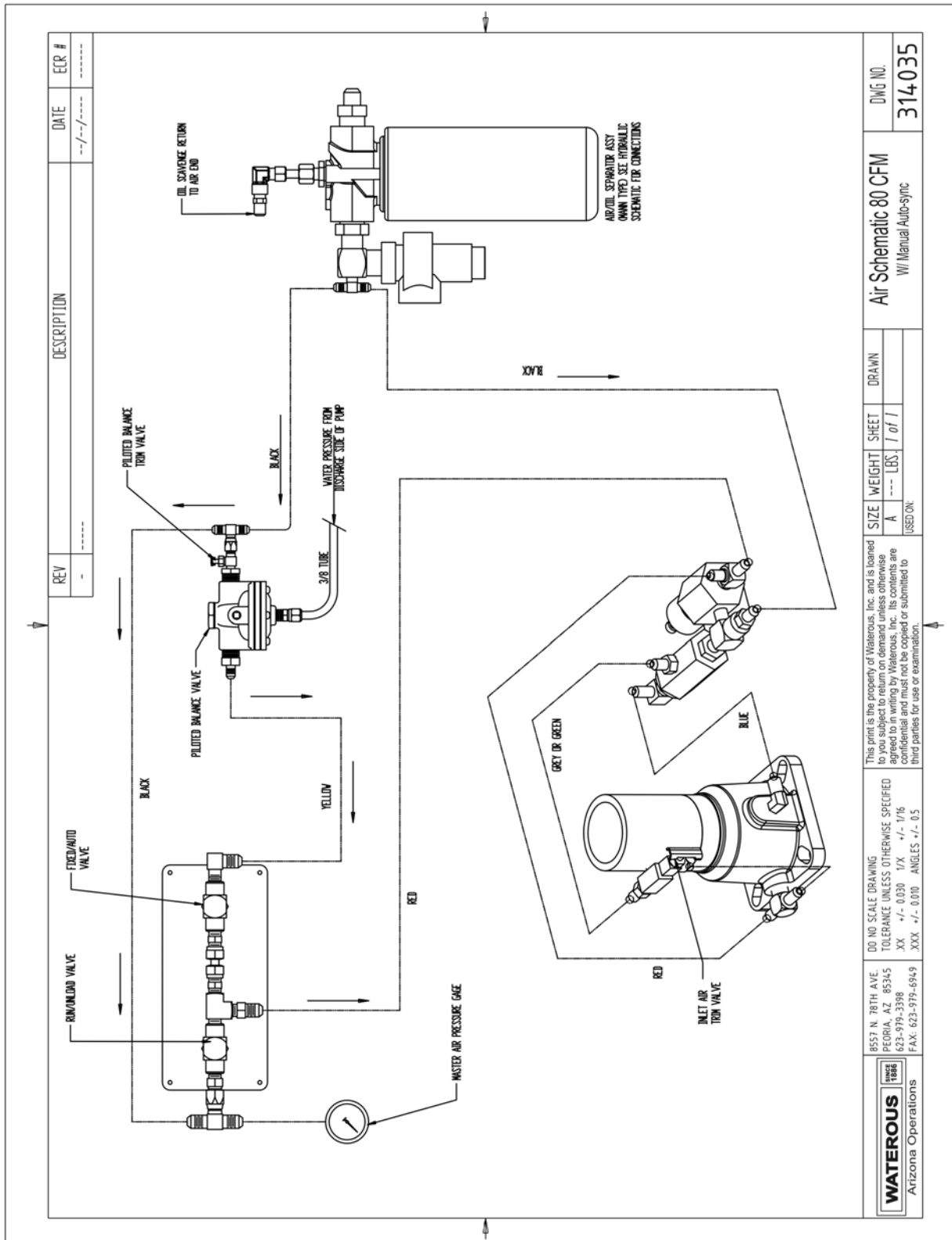

Figure 38 Hydraulic Schematic, Horizontal Sump (Optional)



WATEROUS Arizona Operations	8557 N. 78TH AVE. PEORIA, AZ 85345 623-979-3398 623-979-6949 FAX: 623-979-6949	DO NO SCALE DRAWING TOLERANCE UNLESS OTHERWISE SPECIFIED .XX +/- 0.030 1/4X +/- 1/16 .XXX +/- 0.010 ANGLES +/- 0.5	This print is the property of Waterous, Inc. and is loaned to the user. It is not to be reproduced, copied, agreed to in writing by Waterous, Inc. Its contents are confidential and must not be copied or submitted to third parties for use or examination.	SIZE A --- LBS. / of / USED ON:	WEIGHT	SHEET / of /	DRAWN	Air Schematic 80 CFM W/ Manual Auto-sync	DWG. NO. 314035
---------------------------------------	--	---	---	------------------------------------	--------	--------------	-------	---	--------------------

Figure 39 Air Schematic, Manual Auto-sync, Vertical Inlet

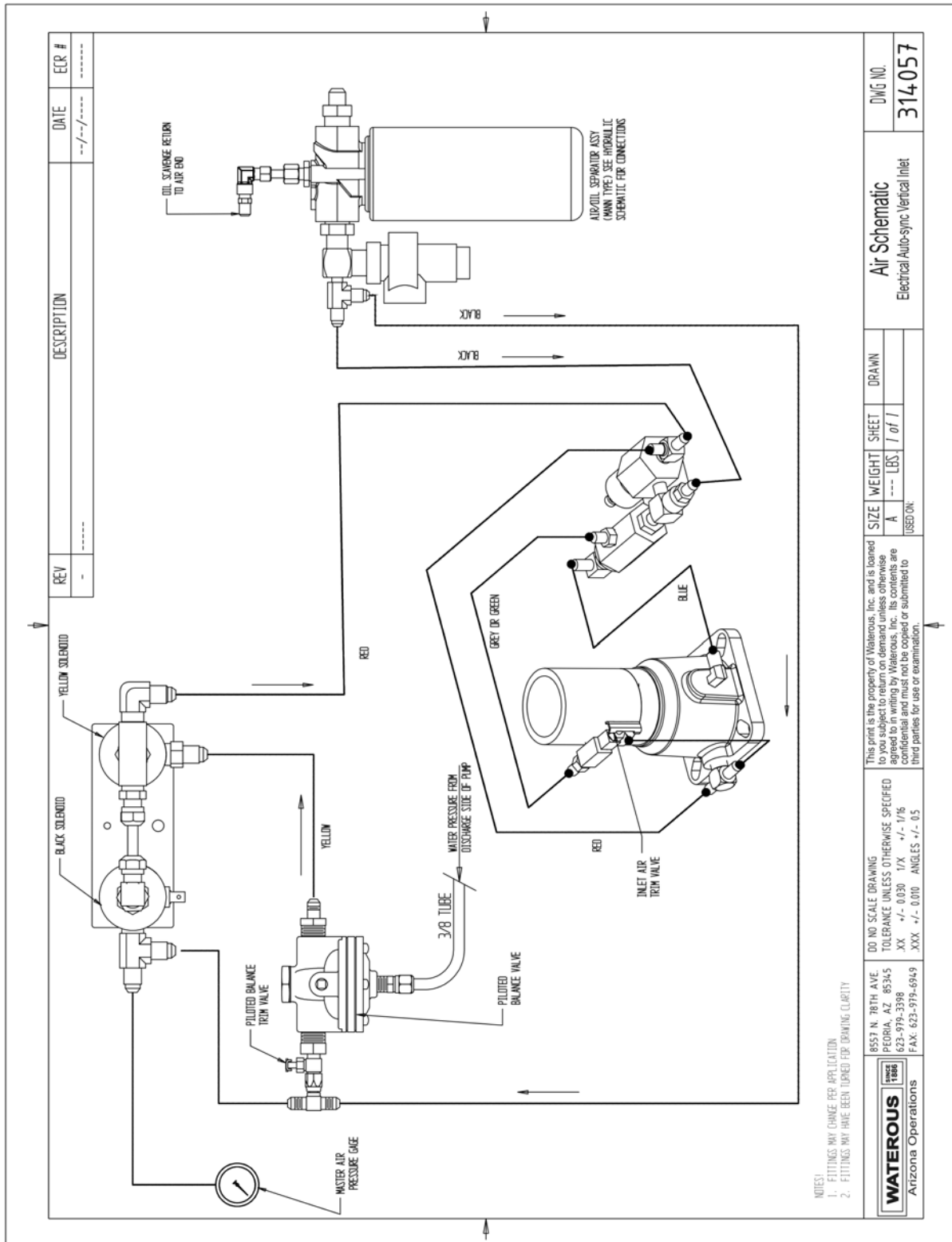

Figure 40 Air Schematic, Electrical Auto-sync, Vertical Inlet

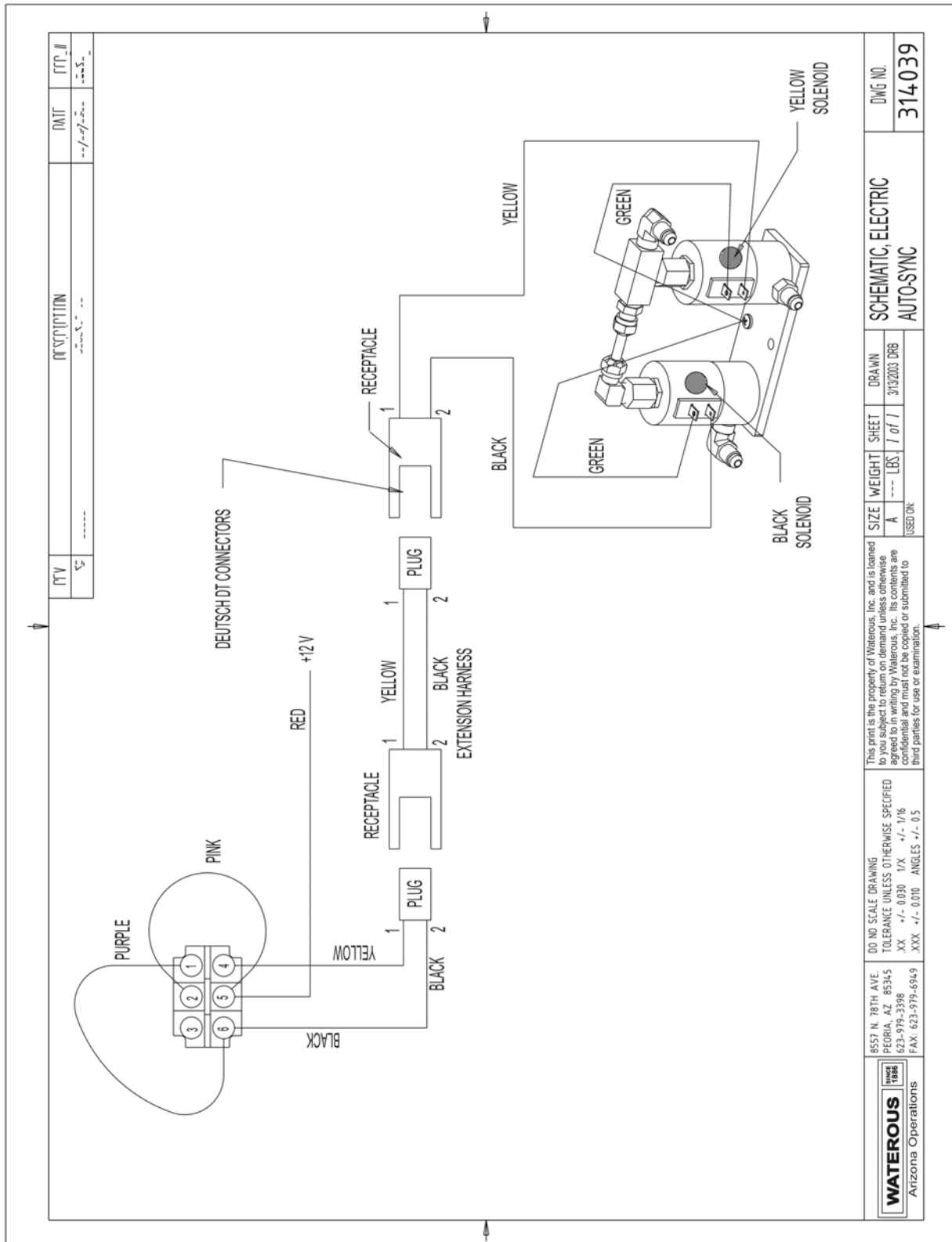

Figure 41 Electric Schematic, Auto-sync

WATEROUS <small>EST. 1988</small> Arizona Operations	8557 N. 78TH AVE. PEORIA, AZ 85345 623-979-3398 FAX: 623-979-6949	DO NOT SCALE DRAWING TOLERANCE UNLESS OTHERWISE SPECIFIED XX +/- 0.030 1/X +/- 1/16 XXX +/- 0.010 ANGLES +/- 0.5	This print is the property of Waterous, Inc. and is loaned to you subject to return on demand unless otherwise specified. Your use of this print is limited to the part identified and must not be copied or submitted to third parties for use or examination.	SIZE A WEIGHT --- LBS. SHEET 1 of 1	DRAWN 3132003 DRB	SCHEMATIC, ELECTRIC AUTO-SYNC	DWG. NO. 314039
---	--	---	---	---	-------------------	----------------------------------	---------------------------

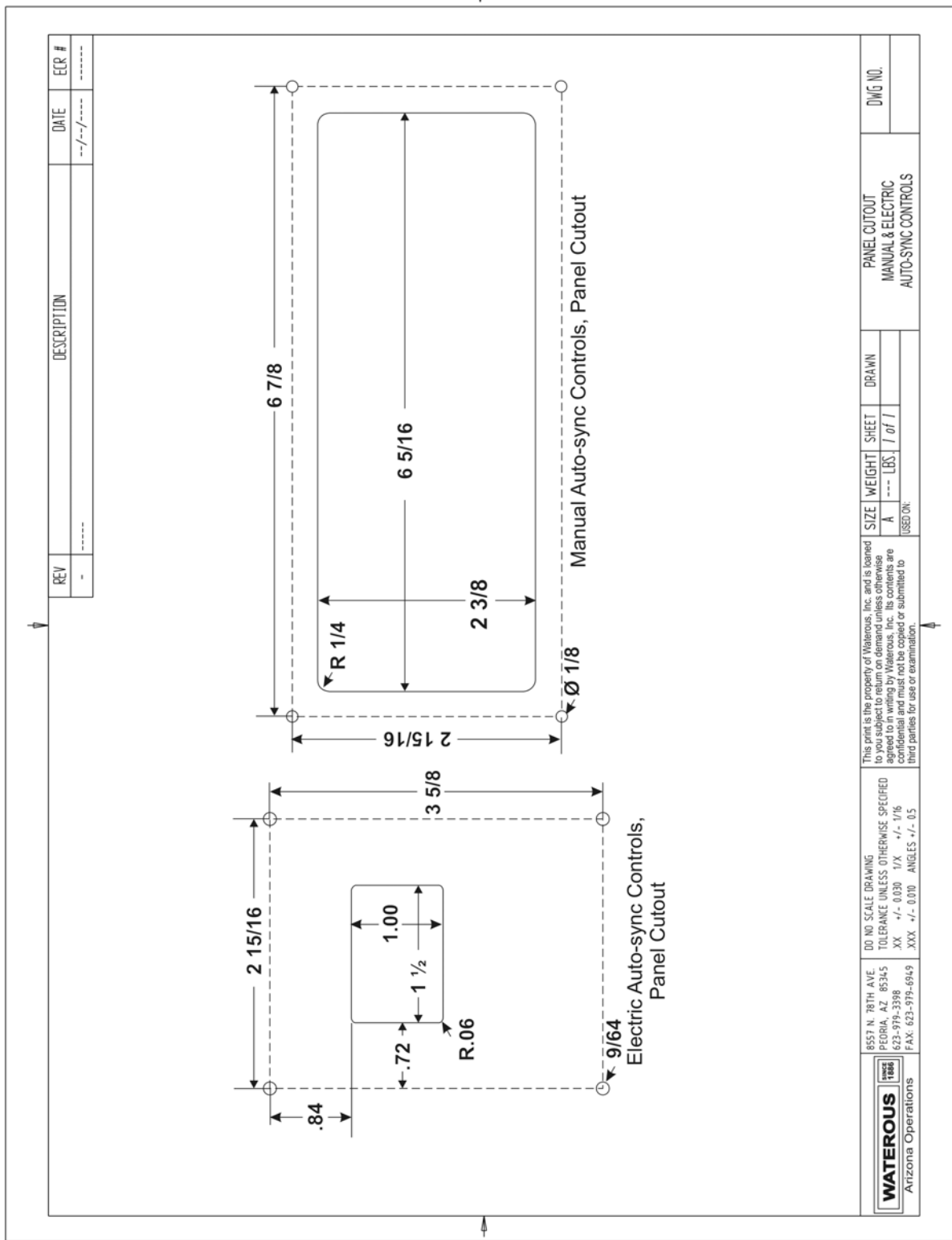

Figure 42 Auto-sync Panel Cutouts

SECTION 8. BASIC DRIVELINE INSTALLATION SUGGESTIONS

A. U-Joint Operating Angles

Every U-joint that operates at an angle creates vibration.

U-joint operating angles are probably the most common cause for driveline vibration in vehicles that have been reworked or that have had auxiliary equipment installed.

When reworking a chassis or installing a new drive shaft in a vehicle, make sure that you follow the basic rules that apply to u-joint operating angles, as follows:

1. U-joint operating angles at each end of a shaft should always be at least 1 °.
2. U-joint operating angles on each end of a drive shaft should always be equal within 1 ° of each other.
3. U-joint operating angles should not be larger than 3°. If more than 3°, make sure they do not exceed the maximum recommended angles for the RPM at which they will be operating.

A u-joint operating angle is the angle that occurs at each end of a drive shaft when the output shaft of the transmission and the input shaft of the pump are not in line. See Figure 43.

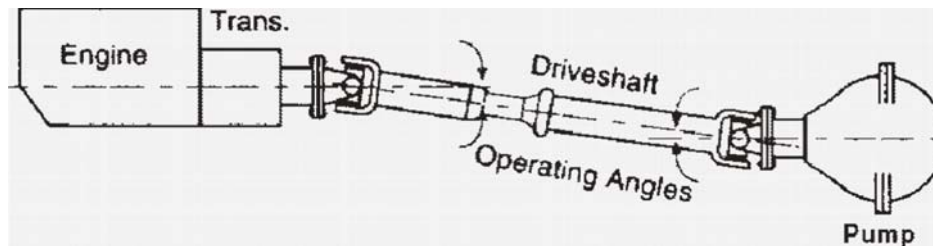

Figure 43 Operating Angle

The connecting drive shaft operates with an angle at each u-joint. It is that angle that creates a vibration.

I. Reducing and Canceling Vibration

A key point to remember about u-joint operating angles: To reduce the amount of vibration, the angles on each end of a drive shaft should always be SMALL.

To cancel an angle vibration, the u-joint operating angles need to be EQUAL within 1 ° at each end of a shaft. See Figure 43.

B. Single Plane and Compound U-Joint Operating Angles

There are two types of u-joint operating angles, single plane and compound.

I. Single Plane

Single plane angles occur when the transmission and pump components are in line when viewed from either the top or side, but not both.

Determine the u-joint operating angle in an application where the components are in line when viewed from the top, but not in line when viewed from the side, is as simple as measuring the slope of the components in the side view, and adding or subtracting those slopes to determine the angle. See Figure 44.

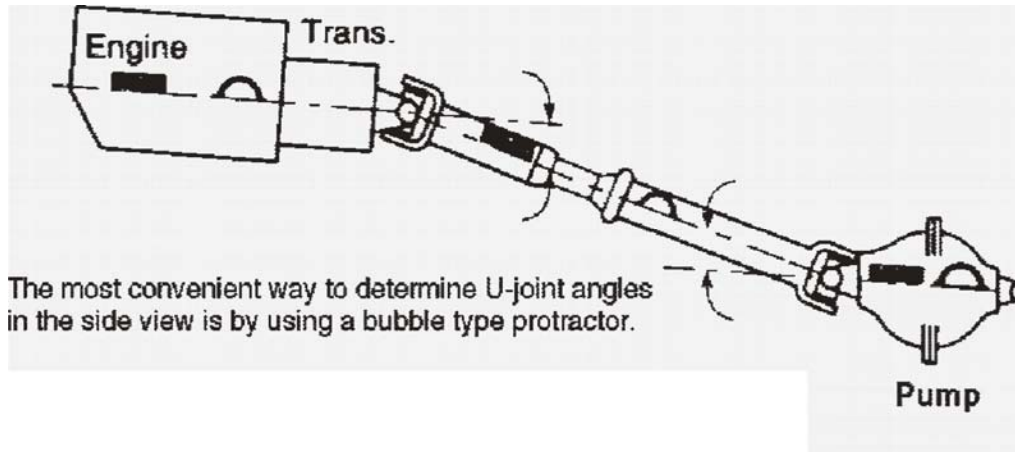

Figure 44 Angles in the side view

These angles should be SMALL and equal within 1°.

Determine the u-joint operating angles on a shaft that is straight when viewed from the side and offset when viewed from the top requires the use of a special chart (See accompanying chart). In this type of application, the centerlines of the connected components must be parallel when viewed from the top, as shown. These angles should also be SMALL and equal within 1°. See Figure 45.

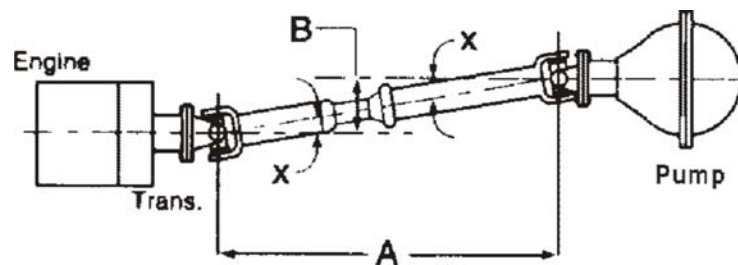

Figure 45 Angles in the top view

Look at the angle chart and note that the smaller the offset, the smaller the resultant angle.

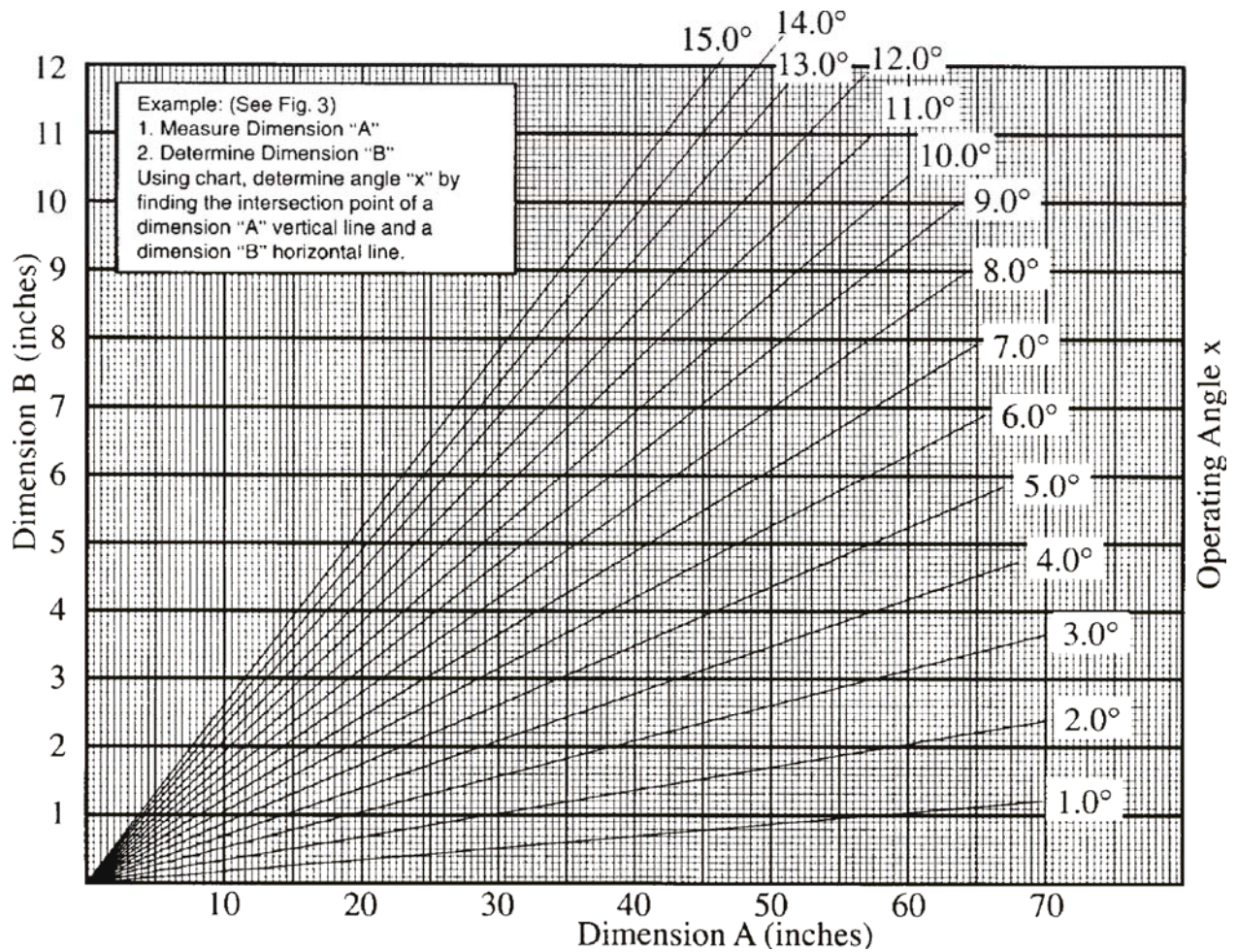

Figure 46 Angle Chart

To reduce the possibility of vibration, keep any offset between connected points to a minimum.

Make sure that the transmission and pump are mounted so that their centerlines are parallel when viewed from both the side and the top.

Make sure the offset between them is small in both views.

II. Compound Angles

Compound u-joint operating angles occur when the transmission and pump are not in line when viewed from both, the top and side. Their centerlines, however, are parallel in both views. See Figure 47.

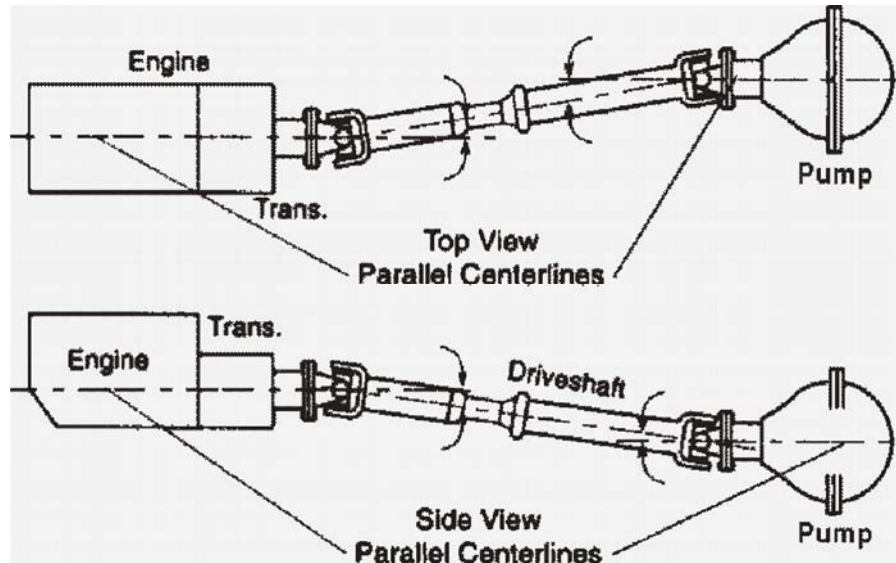

Figure 47 Compound Operating Angles

III. True U-Joint Operating Angle

The true u-joint operating angle, which must be calculated for each end of the shaft with compound angles, is a combination of the u-joint operating angle in the top view, as determined from the chart, and the measured u-joint operating angle in the side view.

To determine the true u-joint operating angle for one end of a shaft, (compound angle C° in the formula shown in figure below) insert the u-joint operating angle measurement obtained in the side view and the u-joint operating angle obtained from the chart into the formula.

$$\text{Compound Angle (C}^\circ) = \sqrt{x^{o2} + a^{o2}}$$

$$x = 2.15^\circ \text{ (A calculated angle)}$$

$$a = 2.5^\circ \text{ (The measured angle)}$$

$$C^\circ = \sqrt{2.15^2 + 2.5^2}$$

$$C^\circ = \sqrt{10.873}$$

$$C^\circ = 3.3^\circ \text{ (True operating angle)}$$

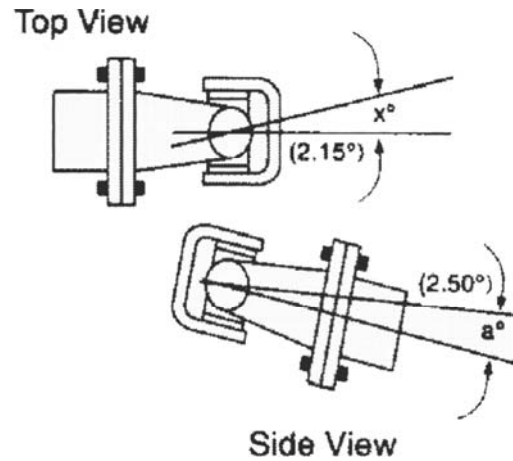

IV. Angle Size

The magnitude of a vibration created by a u-joint operating angle is proportional to the size of the u-joint operating angle. The drive shaft manufacture(s) recommends true u-joint operating angles of 3° or less.

Obtain the true u-joint operating angle, as explained above, and if it is greater than 3° , compare it to the following chart.

DRIVESHAFT (RPM)	MAXIMUM ANGLE
5000	3.2°
4500	3.7°
4000	4.2°
3500	5.0°
3000	5.8°
2500	7.0°
2000	8.7°

The angles shown on the chart are the MAXIMUM u-joint operating angles recommended by the drive shaft manufacture(s) and are directly related to the speed and length of the drive shaft. Any u-joint operating angle greater than 3° will lower u-joint life and may cause vibration. Remember to check maximum safe drive shaft RPM as recommended by the drive shaft manufacturer.

When the PTO output shaft centerline and compressor input shaft centerline are parallel, the u-joint operating angle permissible is length of drive shaft divided by five.

Example: A short coupled drive shaft with a 15" length would be limited to 3 degrees maximum operating angle. A 30" shaft would be limited to 6 degrees.

C. Eliminating Compound Angle Induced Vibrations

Compound u-joint operating angles are one of the most common causes for driveline vibration. To avoid these problems, remember these important considerations:

When setting up an application that requires compound u-joint operating angles, always keep the centerlines of the transmission and pump parallel in both views.

Always keep the offset between their horizontal and vertical centerlines small.

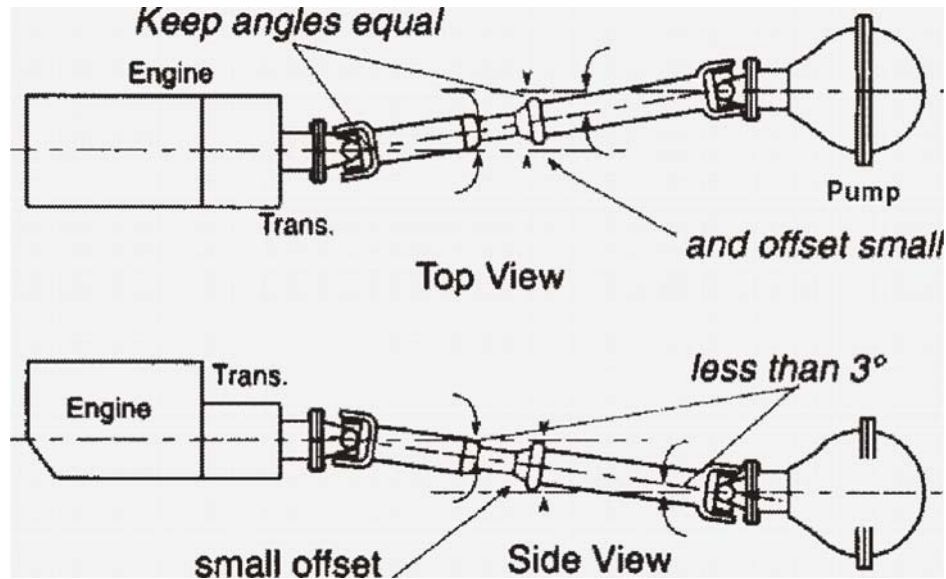

Note: Centerlines of transmission and axle must be parallel in both top and side views to use this method of determining true u-joint operating angle. Contact the drive shaft manufacture(s) for technical support if you have an application which cannot be installed with their centerlines parallel.

SIDE VIEW OPERATING ANGLE CALCULATIONS WITH UP HILL SHAFT

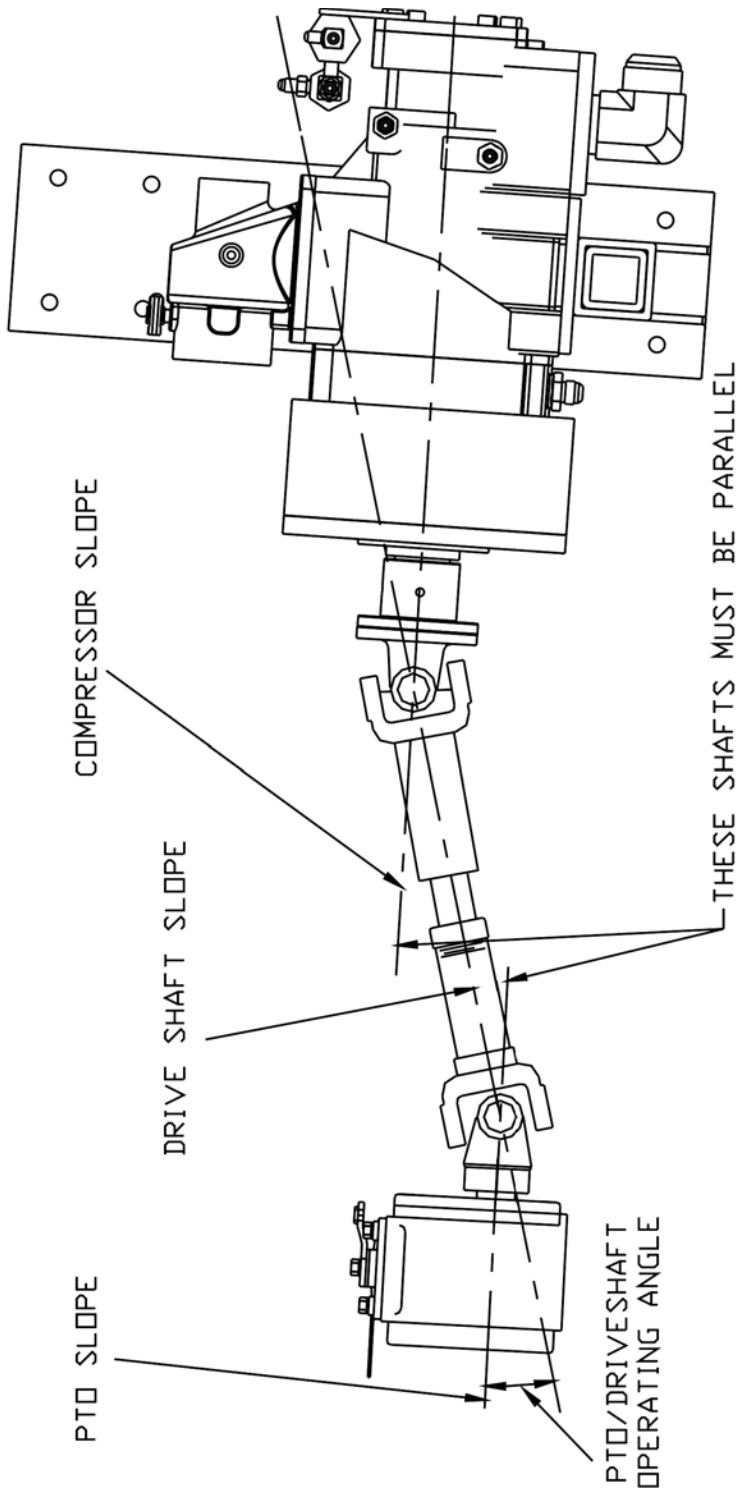

SIDE VIEW OPERATING ANGLE CALCULATIONS

$$\begin{array}{r}
 \text{PTO SLOPE} \\
 \text{SHAFT SLOPE} \\
 + \\
 \text{DEGREE DOWN} \\
 \text{DEGREE UP} \\
 \text{PTO/DRIVE SHAFT} \\
 \text{OPERATING ANGLE} \\
 =
 \end{array}
 \qquad
 \begin{array}{r}
 \text{SHAFT SLOPE} \\
 \text{COMPR. SLOPE} \\
 + \\
 \text{PTO/DRIVE SH} \\
 \text{OPERATING ANI} \\
 =
 \end{array}
 \qquad
 \begin{array}{r}
 \text{DEGREE UP} \\
 \text{DEGREE DOWN} \\
 \text{PTO/DRIVE SH} \\
 \text{OPERATING ANI}
 \end{array}$$

OPERATING ANGLES MUST BE WITHIN 1 DEGREE OF EACH OTHER

Figure 48 Operating Angle - Uphill

SIDE VIEW OPERATING ANGLE CALCULATIONS WITH DOWN HILL SHAFT

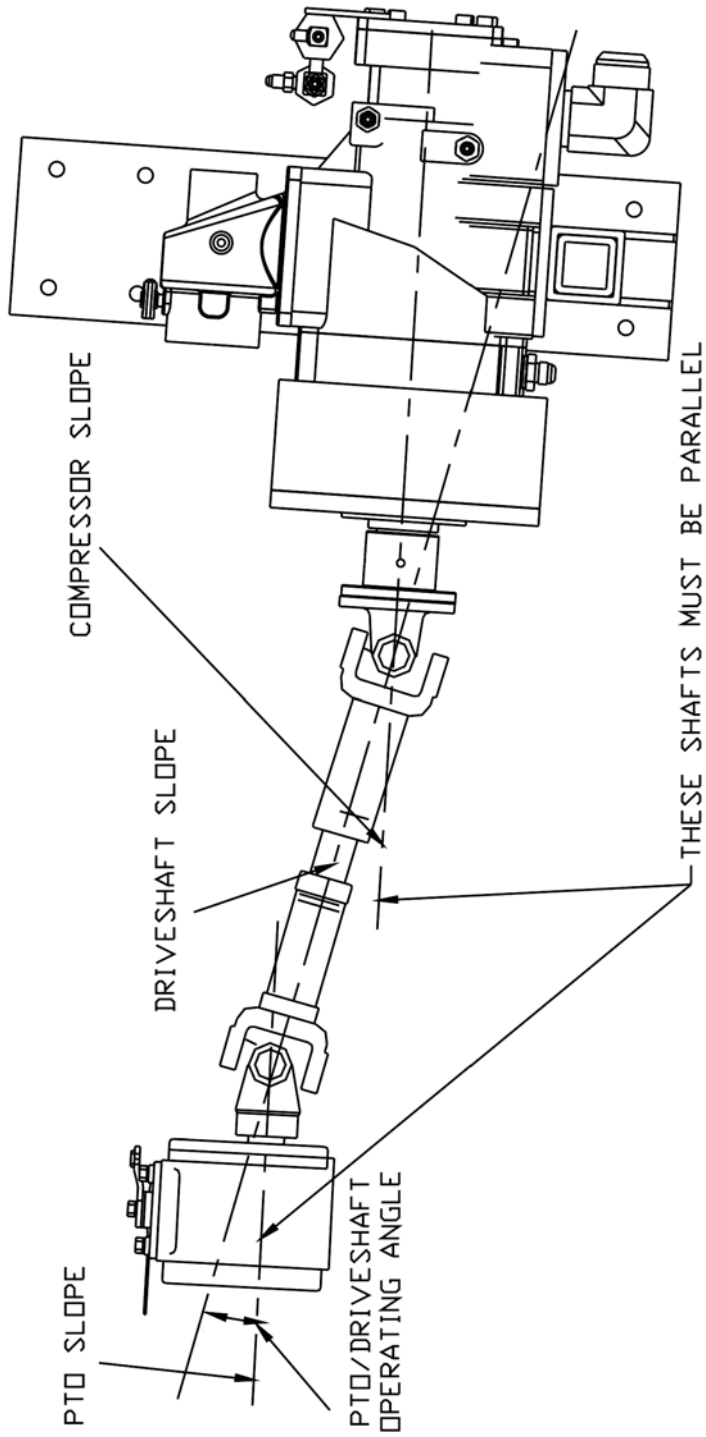

SIDE VIEW OPERATING ANGLE CALCULATIONS

$$\begin{array}{r}
 \text{PTO SLOPE} \text{---} \\
 \text{SHAFT SLOPE} \\
 - \\
 \hline
 = \text{PTO/DRIVE SHAFT OPERATING ANGLE}
 \end{array}
 \qquad
 \begin{array}{r}
 \text{SHAFT SLOPE} \text{---} \\
 \text{COMPR. SLOPE} \\
 - \\
 \hline
 = \text{PTO/DRIVE SHAFT OPERATING ANGLE}
 \end{array}$$

OPERATING ANGLES MUST BE WITHIN 1 DEGREE OF EACH OTHER

DRIVELINE RUNOUT SPECIFICATIONS

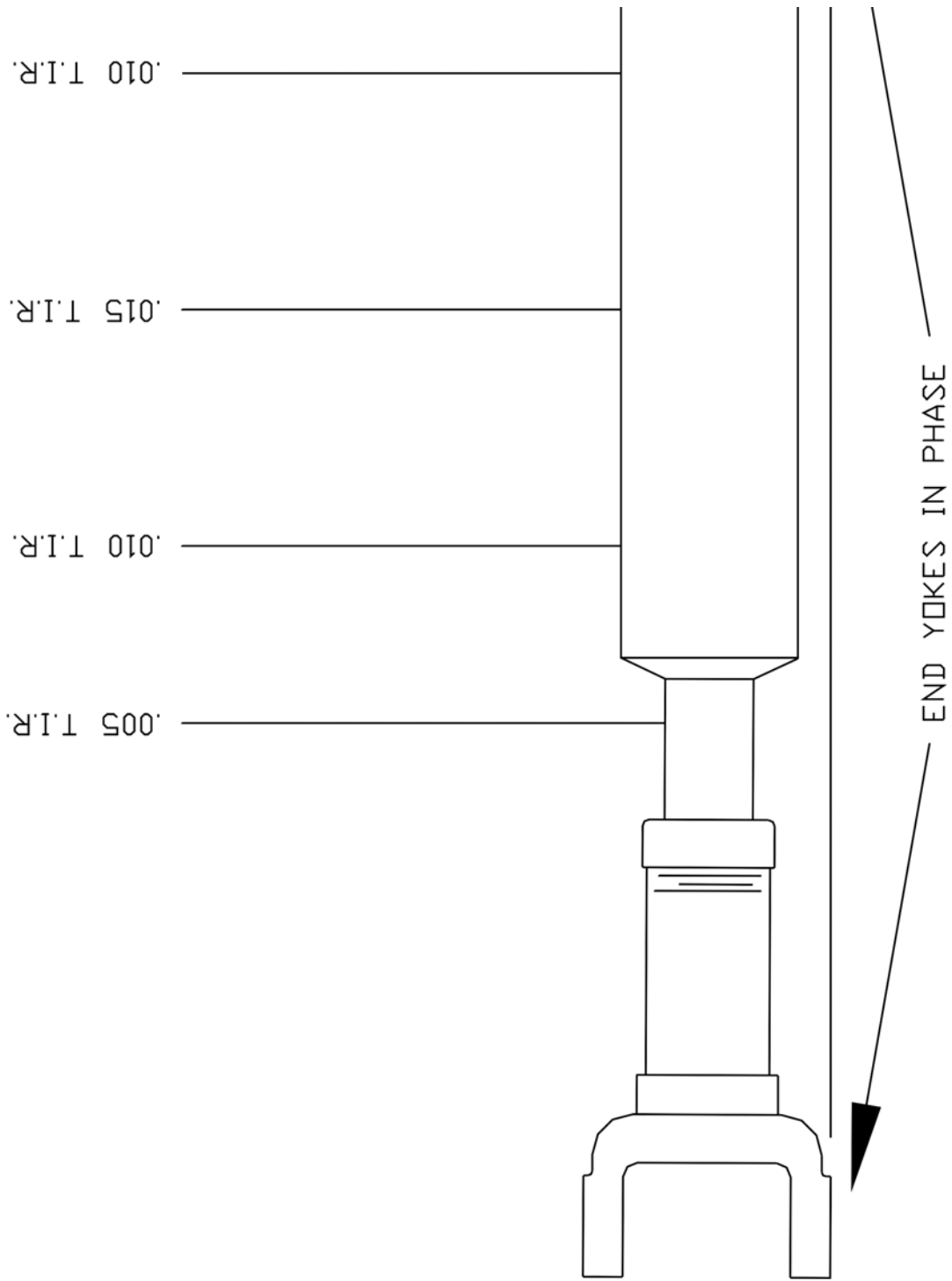

Figure 50 Driveline Run-out Spec

SECTION 9. CONDITIONAL 5-YEAR WARRANTY POLICY

WATEROUS warrants, to the original Buyer only, that products and parts manufactured by WATEROUS will be free from defects in material and workmanship under normal use and service for a period of five (5) years from the date the product is first placed in service, or five and one-half (5-1/2) years from the date of shipment by WATEROUS, whichever period shall be the first to expire; provided the Buyer notifies WATEROUS, F-1031, Section 3035

in writing, of the defect in said product within the warranty period, and said product is found by WATEROUS to be nonconforming with the aforesaid warranty. When required in writing by WATEROUS, defective products must be promptly returned by Buyer to WATEROUS at WATEROUS plant at Glendale, Arizona, or at such other place as may be specified by WATEROUS, with transportation and other charges prepaid. A Returned Material Authorization (RMA) is required for all products and parts and may be requested by phone, fax or mail. The aforesaid warranty excludes any responsibility or liability of WATEROUS for:

- a) damages or defects due to accident, abuse, misuse, abnormal operating conditions, negligence, accidental causes, or improper maintenance, or attributable to written specifications or instructions furnished by Buyer;
- b) defects in products manufactured by others and furnished by WATEROUS hereunder, it being understood and agreed by the parties that the only warranty provided for such products shall be the warranty provided by the manufacturer thereof which, if assignable, WATEROUS will assign to Buyer, if requested by Buyer;
- c) any product or part, altered, modified, serviced or repaired other than by WATEROUS, without its prior written consent; and
- d) the cost of dismantling, removing, transporting, storing, or insuring the defective product or part and the cost of reinstallation.
- e) normal wear items (including, but not limited to belts, hoses, check valves, packing, strainers, filters, light bulbs, anodes, intake screens, mechanical seals, etc.).

This warranty is subject to WATEROUS Conditions of Sale (detailed on WATEROUS Invoice) as currently in effect all of which are herein incorporated and by this reference made a part hereof

All other warranties are excluded, whether express or implied by operation **of law or otherwise, including all implied warranties of merchantability or fitness for purpose. WATEROUS shall not be liable for consequential or incidental damages directly or indirectly arising or resulting from the breach of any of the terms of this limited warranty or from the sale, handling, or used of any WATEROUS product or part. WATEROUS liability hereunder, either for breach of warranty or for negligence, is expressly limited at WATEROUS option:**

- a) to the replacement at the agreed point of delivery of any product or part, which upon inspection by WATEROUS or its duly authorized representative, is found not to conform to the limited warranty set forth above, or
- b) to the repair of such product or part, or
- c) to the refund or crediting to buyer of the net sales price of the defective product or part. Buyers remedies contained herein are exclusive of any other remedy otherwise available to Buyer.

Waterous, Arizona Operations
7612 North 74th Ave.
Glendale, Arizona 85303
www.waterousco.com



Compressed Air Foam Systems