

Discharge Relief Valve

Installation Instructions

Form No.	Section	Issue Date	Rev. Date
F-1031	3073	9/9/19	

Table of Contents

System Description	2
Installation	
Relief Valve	3, 5
Pilot Valve	6, 7
Piping	8, 9
Wiring	10
Valve Light Switch Adjustment	10

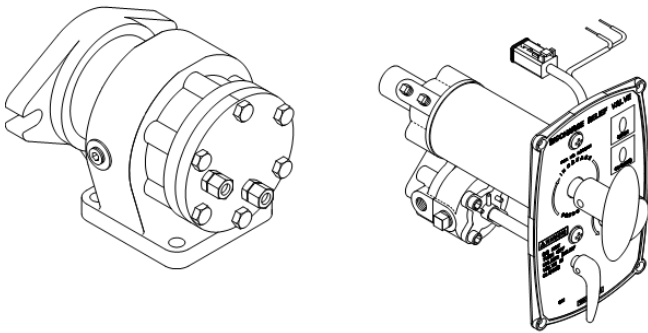

IL3031_2



Read through the installation instructions carefully before installing your Waterous Pressure Control Systems.

WATEROUS

Fire Pumps – Since 1886

Visit us at www.waterousco.com

System Description

The Waterous discharge relief valve system provides sensitive pump control to protect firefighters from sudden pressure surges resulting from changes in discharge flows from the pump. Designed with a “built-in-memory”, this system has a wide continuous range of pressure control from a minimum of 90 to a maximum of 300 psig depending upon pump performance characteristics, and may be put in or taken out of operation without disturbing the pressure setting. This lets you leave the system at a pre-set, ready-to-use pressure setting.

The Waterous discharge relief valve system incorporates two separate units; a panel-mounted pilot valve which controls the operation of the relief valve, and the relief valve which is normally mounted on the pump.

The pilot valve has two controls, one to adjust the relief valve operating pressure, and the other, an ON-OFF control, to place the relief valve in or out of operation.

Turning the ON-OFF control to OFF puts the relief valve out of operation (hydraulically holding the relief valve

closed) when a pressure higher than set pressure or higher than 300 psig is desired. Turning this control to ON permits the relief valve to operate again at whatever pressure was previously set without further adjustment.

The relief valve is mounted on the pump or in the piping between the intake and discharge sides of the pump. It modulates flow between discharge sides and intake by ranging between the fully open and fully closed position in response to hydraulic signals from the pilot valve. The relief valve is available in three sizes. For pumps with rated capacities of 750 gpm or less, a two inch outlet diameter relief valve is used. For pumps with rated capacities through 1250 gpm, a three inch outlet diameter relief valve is used. For 1500 gpm through 2250 gpm, a four inch outlet diameter relief valve is recommended.

On indicating relief valves two indicator lights show the position of the relief valve; green for fully closed and amber for at least partially open.

Figure 1. Discharge Relief Valve System

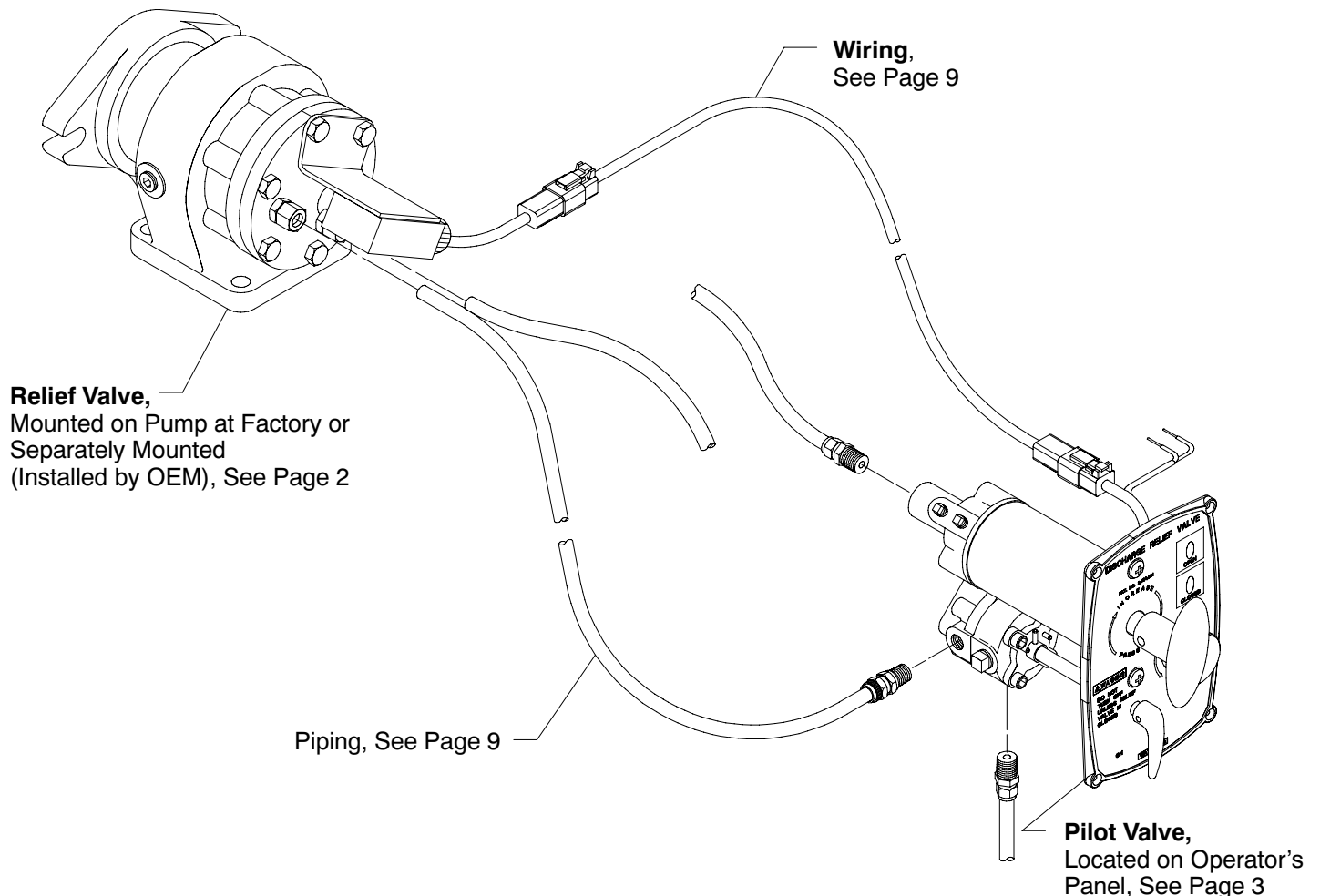

Relief Valve Installation

1. On most Waterous pumps, the relief valve will be installed at the factory. Occasionally the relief valve must be mounted and piped when the pump is installed. Suitable flanges are available from Waterous Company to install 2 inch, 3 inch and 4 inch relief valves in a standard piping system.
2. When selecting a location, keep the piping between pump intake and the relief valve as short and straight as possible to reduce the amount of friction loss.
3. To ensure proper draining, the relief valve cannot be mounted with either opening facing up.
4. See Table 1 for details of separately mounted relief valves:

Table 1. Separately Mounted Relief Valve Details

Valve Size	End Connections	See Figure
2 in.	2 in. NPT	2
	2-1/2 in. NPT	
	Blank 4-Bolt Flange	
3 in.	3 in. NPT	3
	3 in. Victaulic	4
4 in.	4 in. NPT or BSP	5
	4 in. Victaulic	6

Figure 2. 2 Inch Relief Valve

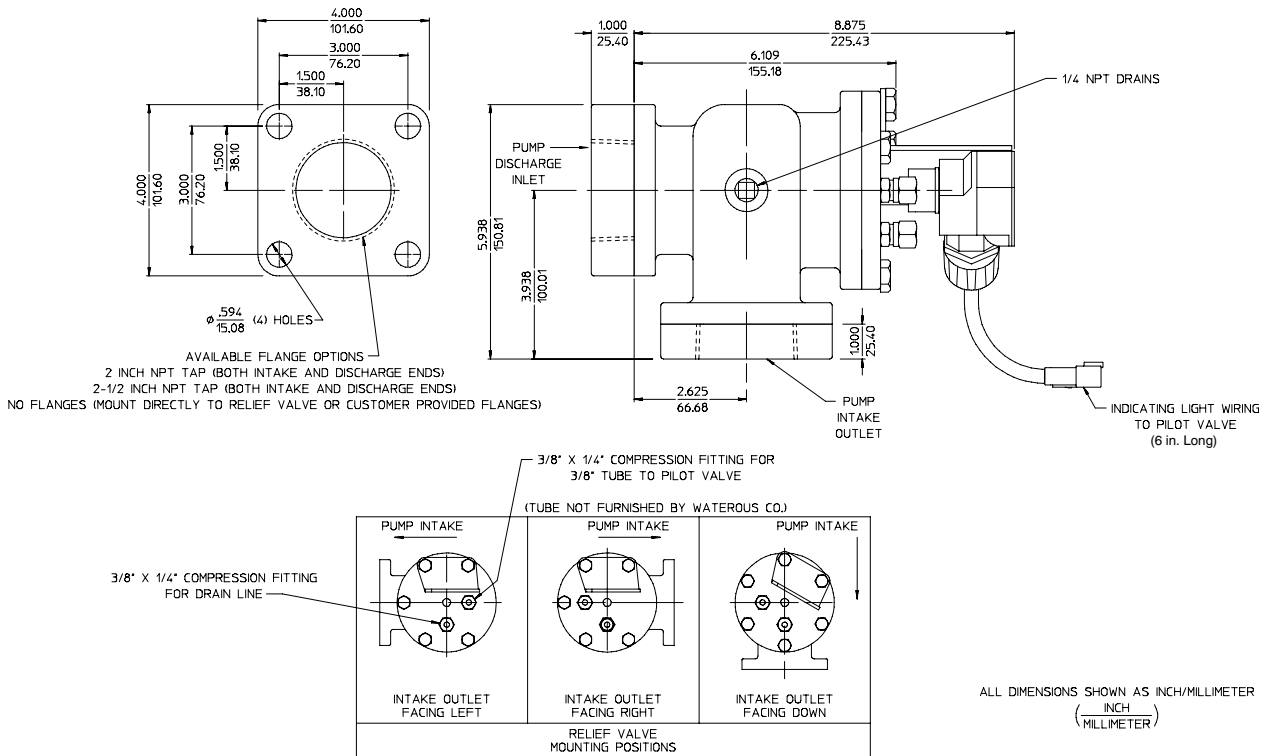

NOTE: CUSTOMER TO FURNISH 3/8" TUBING TO PILOT VALVE AND FURNISH PIPING FROM PUMP DISCHARGE AND TO PUMP INTAKE.

From PL82084_4

Relief Valve Installation

Figure 3. 3 Inch Relief Valve (NPT)

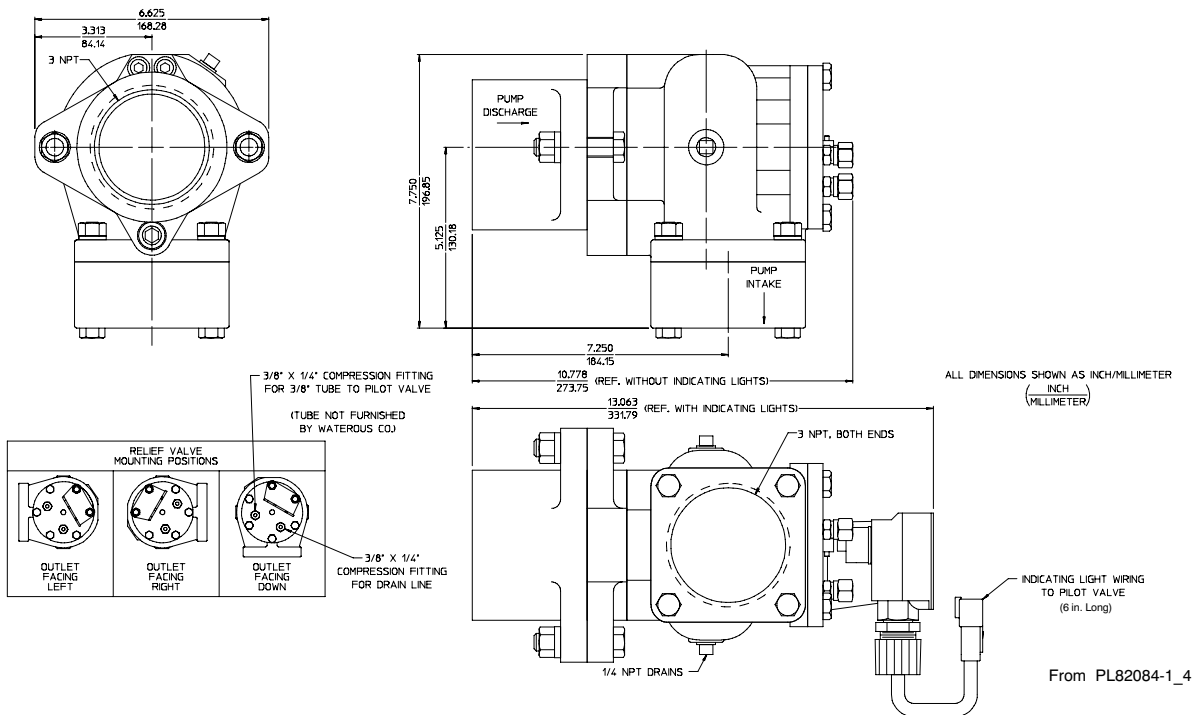
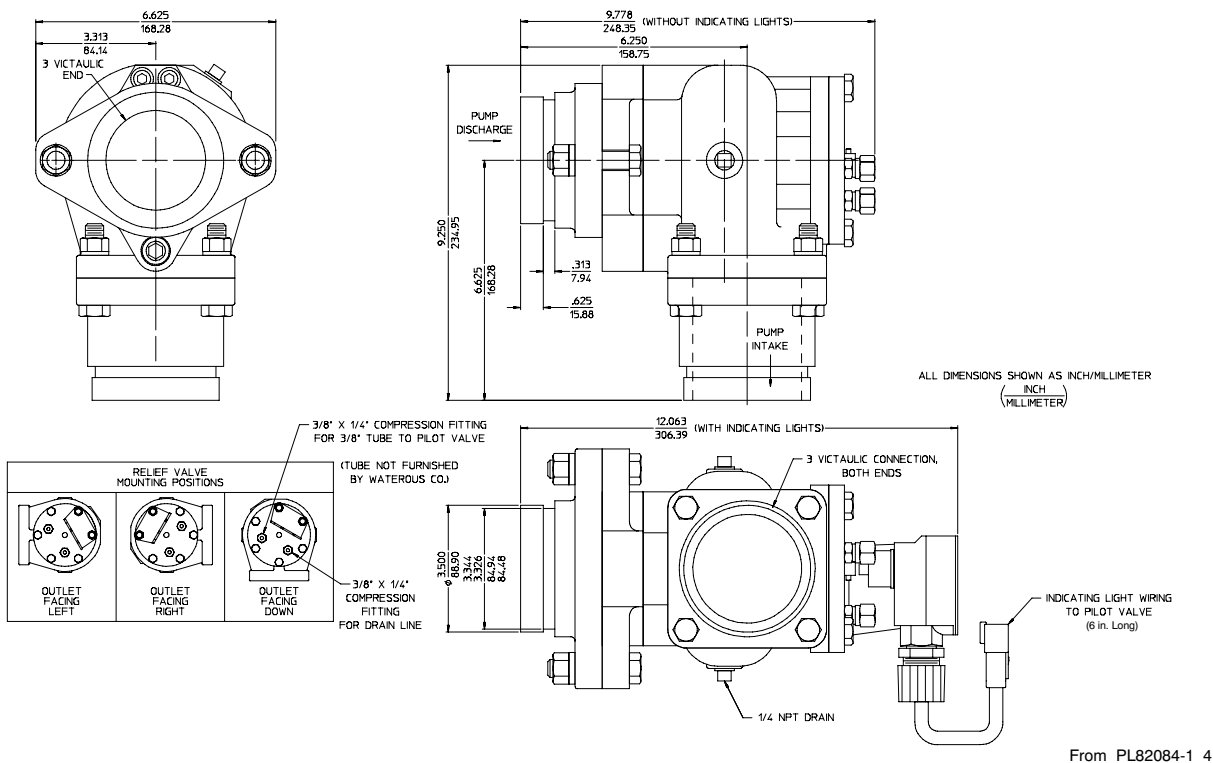

Figure 4. 3 Inch Relief Valve (Victaulic®)



Relief Valve Installation

Figure 5. 4 Inch Relief Valve (NPT or BSP)

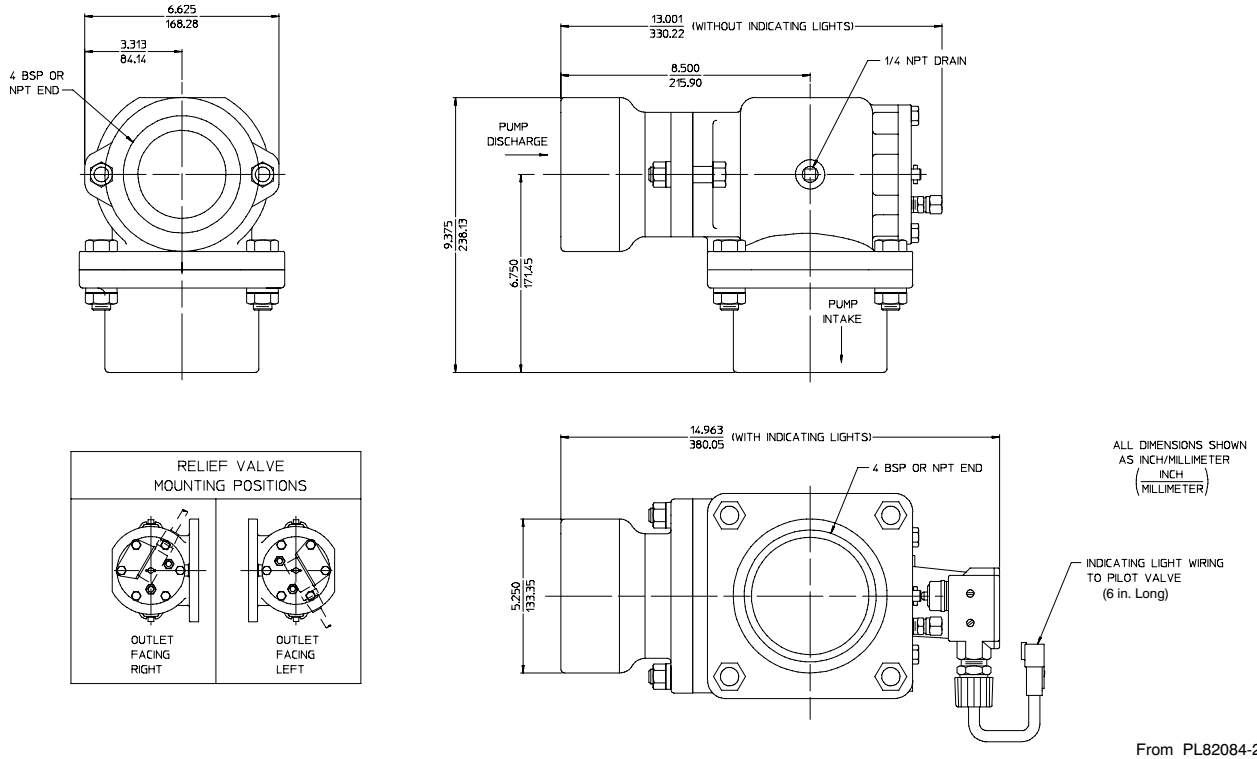
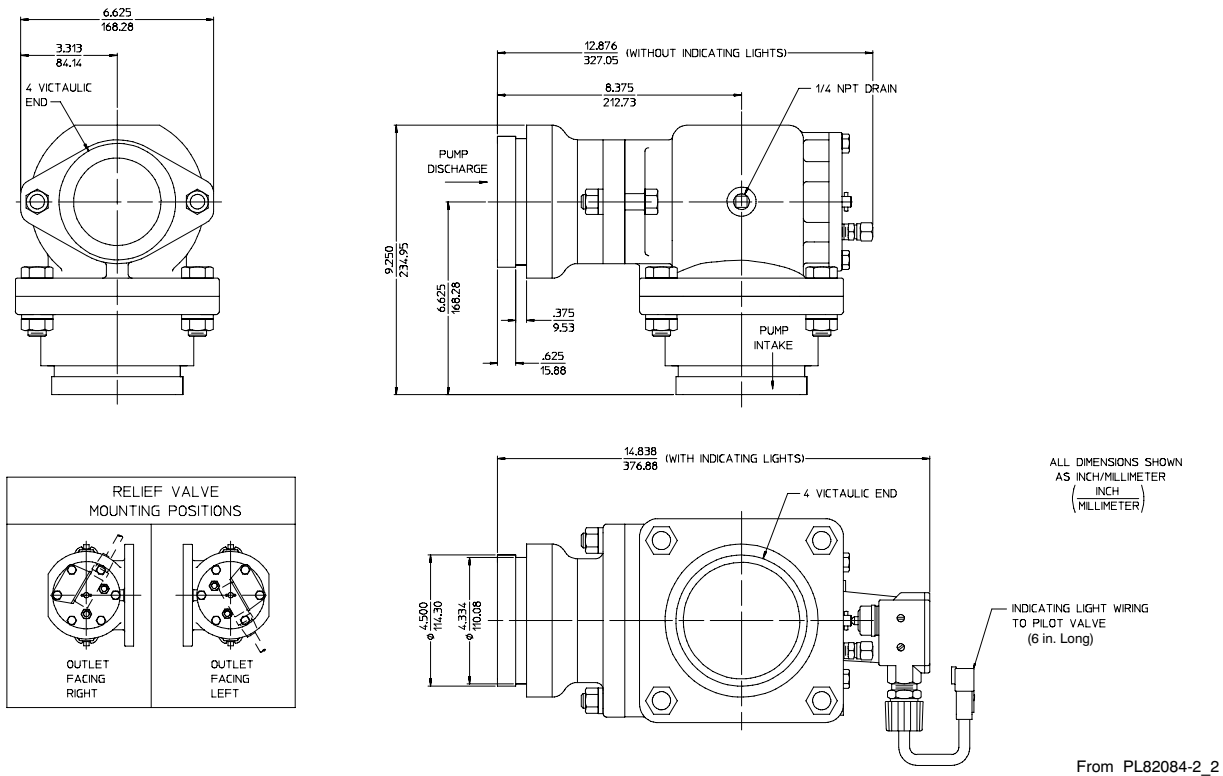

Figure 6. 4 Inch Relief Valve (Victaulic®)



Pilot Valve Installation

1. When mounting the pilot valve, choose a location which is higher than the pump. This will eliminate the need to install a separate drain to the pilot valve. See Figure 8 for dimensions of pilot valve.
2. Position the panel plate on the operator's panel and mark the location of the screw holes. Also mark the square cut-out (see the panel cut-out detail in Figure 7). Deburr all holes and openings cut in the panel.
3. Unscrew the strainer from the pilot valve and set aside. Take care not to damage the O-rings on the strainer.
4. Install the panel plate on the valve by sliding the plate over the Pressure Adjustment and On-Off control stems. Secure the panel to the valve with the (2) screws, washers and nuts furnished.
5. Install the Panel/Valve assembly in the panel. Secure to the panel with the (4) screws and nuts provided. Use a thread locking compound on the screws and nuts.
6. Install the Pressure Adjustment Knob and On-Off Lever on the protruding stems using the pins provided.
7. Install the strainer through the opening in the panel and thread into the valve body. Tighten hand tight.
8. See Page 8 for piping connections and Page 9 for wiring connections.

Figure 7. Pilot Valve Installation

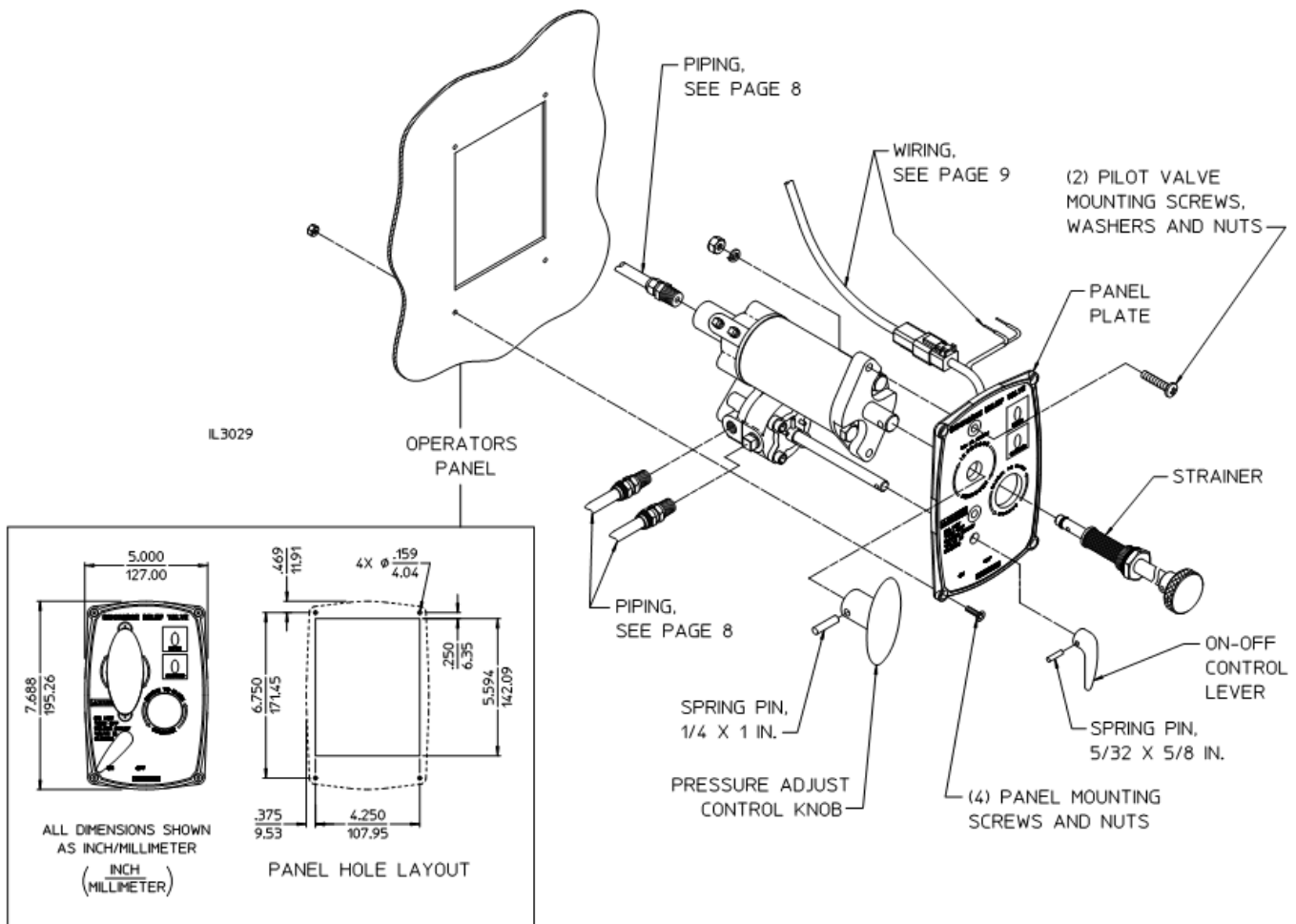

Pilot Valve Installation

Figure 8. Pilot Valve Dimensions

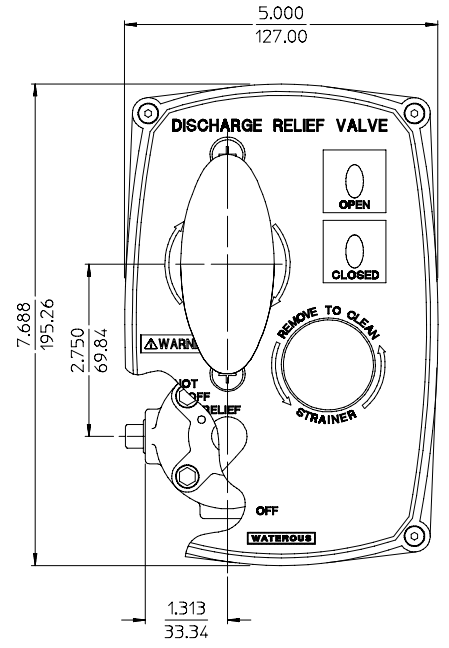
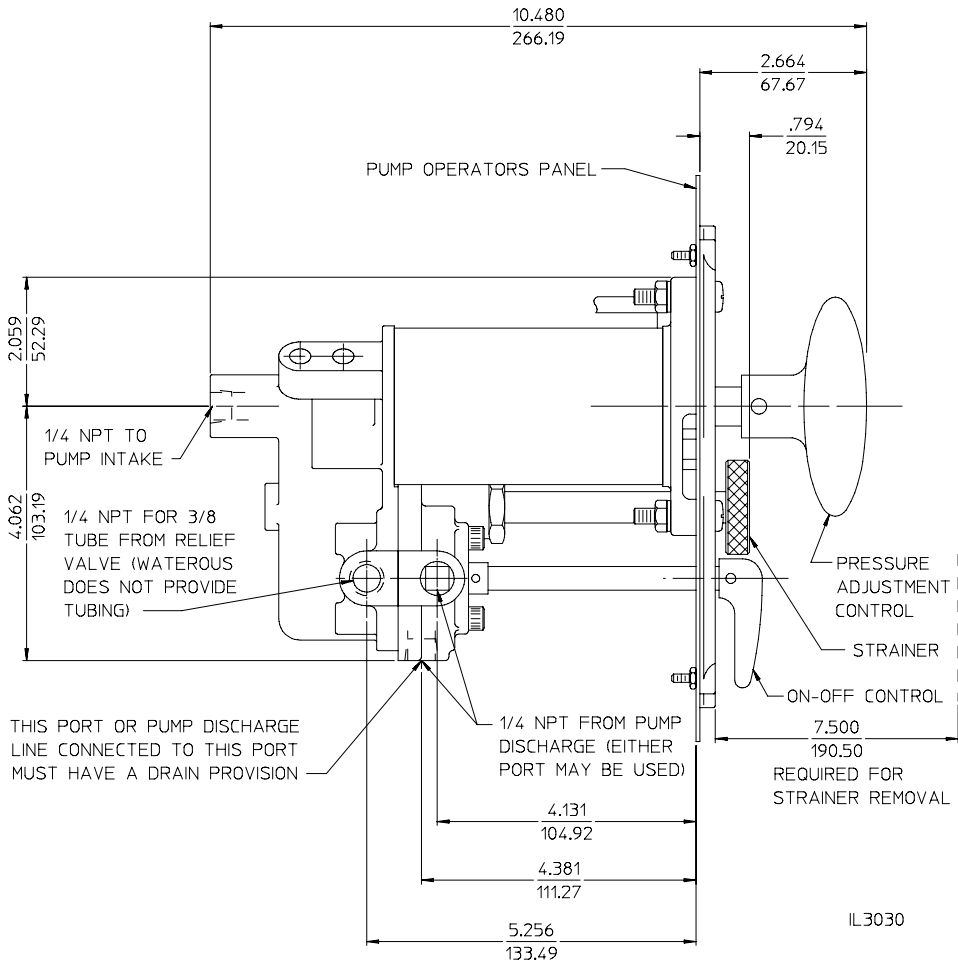

ALL DIMENSIONS SHOWN AS INCH/MILLIMETER
 (INCH)
 (MILLIMETER)

Piping Installation (See Figure 9)

Use 3/8 inch I.D. tubing for all connections (the ports are 1/4 inch NPT). Tubing should be rated at 600 psi minimum working pressure and 1400 psi burst pressure. Excessive pressure surges and erratic operation may result if a smaller size tube is used. Make sure all lines are free of low spots or sharp bends which will prevent the lines from draining properly.

WARNING

All tubing lines connected to the pilot valve should be dedicated lines. Any pressure fluctuations from devices connected to them will cause the system to malfunction.

1. If the pilot valve is installed higher than the pump, connect a line from the bottom discharge port to the same tap used for the pump pressure gauge. The side pump discharge port should be plugged. If the pilot valve is installed lower than the pump, connect a line from the side discharge port to the same tap used for the pump pressure gauge. The bottom port will be used for a drain.
2. Connect a line from the relief valve port of the pilot valve to the upper port on the relief valve cap.

WARNING

Do not connect anything else into this line.

3. Connect a line from the pump intake port of the pilot valve to an intake pressure tap.

4. If necessary, install a drain line from the bottom port of the pilot valve to a separately controlled drain valve. (This is necessary if the pilot valve is mounted lower than the pump.

WARNING

Do not connect the drain line to a multi-port drain valve.

5. Install a drain line from the lower port on the relief valve cap to a separately controlled drain.

NOTE: The relief valve cap may need to be rotated to position the drain port at the bottom.

WARNING

Do not connect the drain line to a multi-port drain valve.

6. Install a drain line from the relief valve body to a multi-port drain or other suitable valve. This port will normally be under intake pressure.
7. Plug all unused ports.

Piping Installation (See Figure 9)

Figure 9. Piping Installation

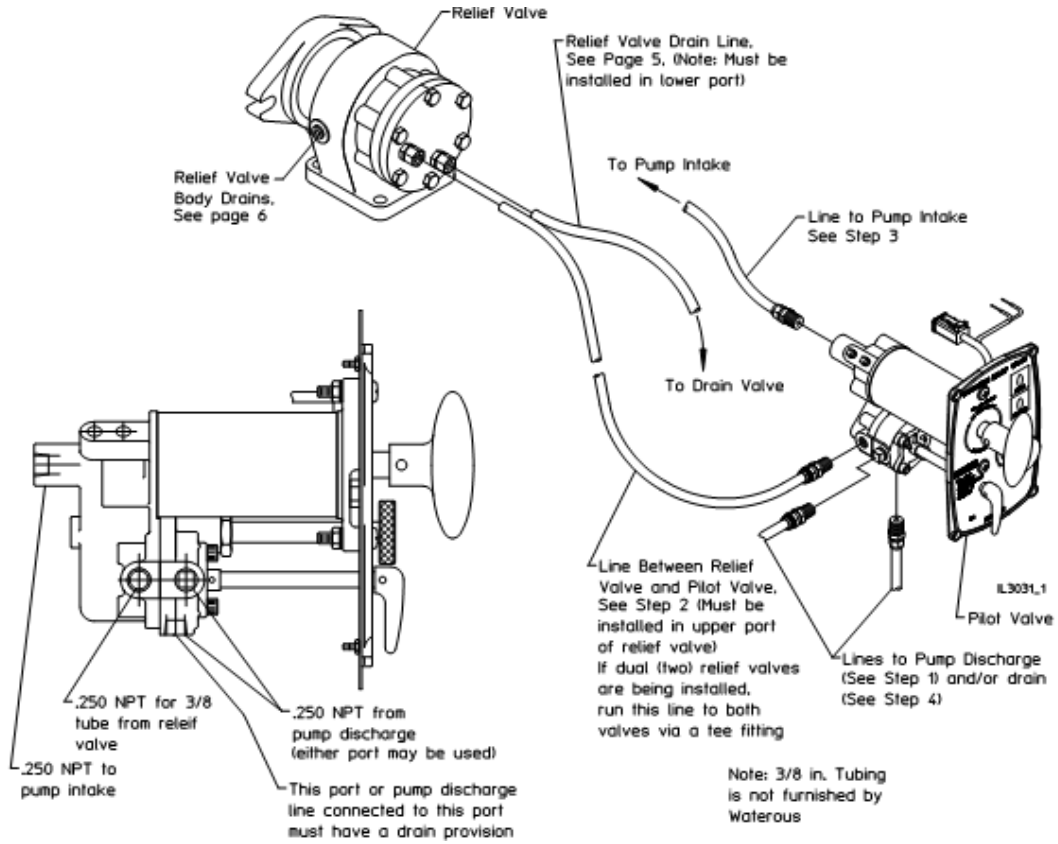

Wiring Installation

1. Connect relief valve switch to the panel bezel LED module (see Figure 10).
2. Connect black wire from pilot valve to ground. Connect white wire to 12 or 24 VDC power supply.
3. If necessary, reposition mounting bracket on relief valve cap so connecting and sealing device is horizontal or points down at least slightly. Although wire connection is sealed, water may collect if connection points up, and may eventually seep along the wires into switch. If the connection must point up, silicone sealant may be used to ensure the wire connection is sealed.

Figure 10. Wiring Installation

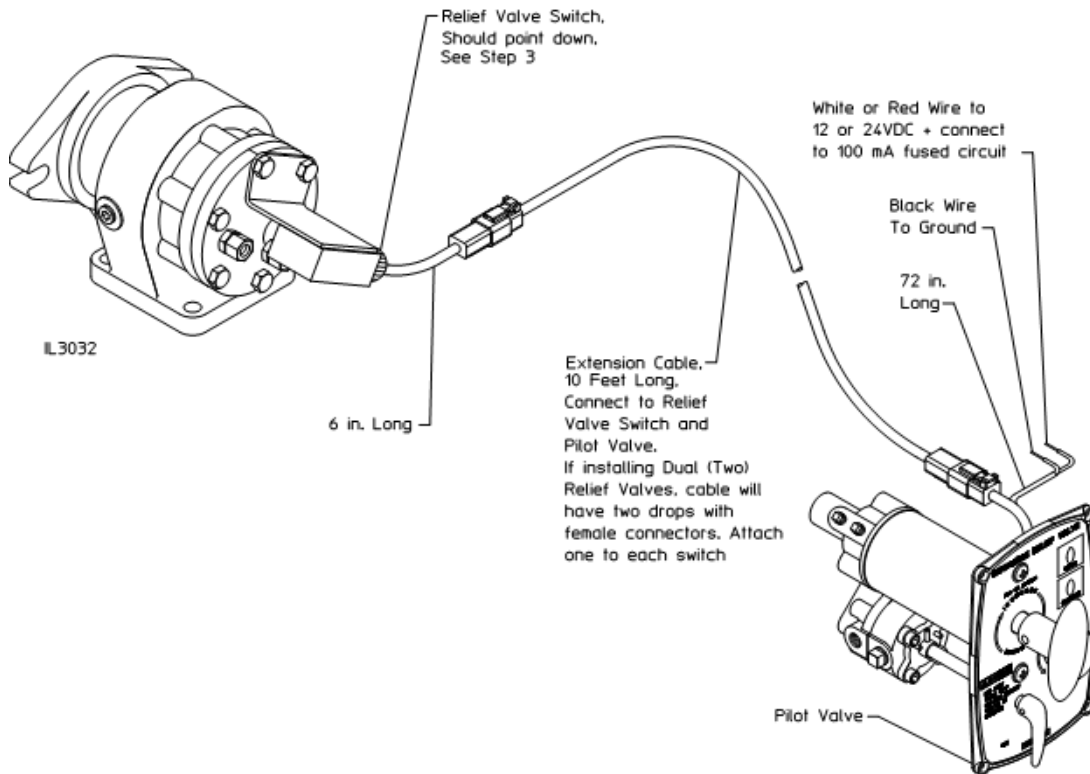

Valve Light Switch Adjustment

1. Adjust the clearance between the switch plunger and actuating rod so that the insertion of a 0.015 inch feeler gage will light the amber indicator, but insertion

of a 0.010 inch gage will not. Loosen switch mounting screws and re-tighten when adjustment is complete.

Figure 11. Valve Light Switch Adjustment

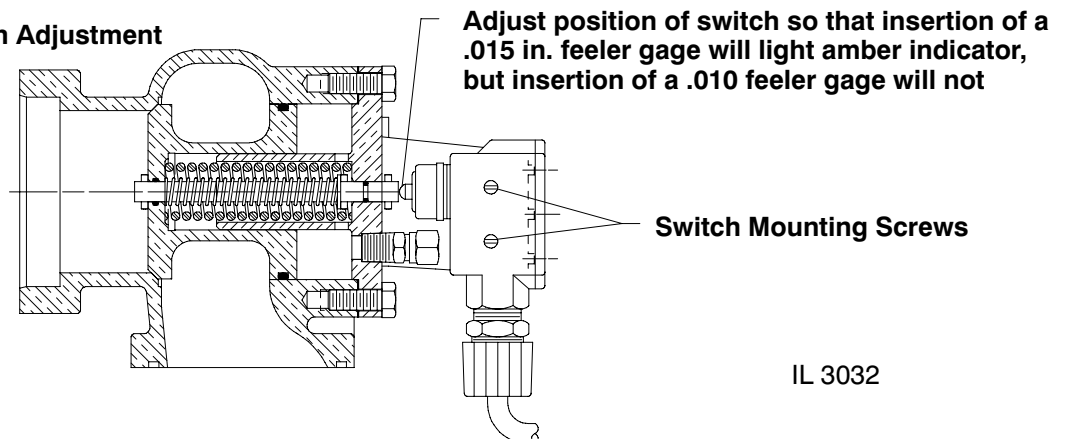

IL 3032

