

Piloted Intake Relief Valve

Installation Instructions

Form No.	Section	Issue Date	Rev. Date
F-1031	3074	9/9/19	1/7/20

Table of Contents

Discharge Relief Valve System

System Description	2
Installation	
Relief Valve	3
Pilot Valve	4, 5
Piping	6
Setting Operating Pressure	7

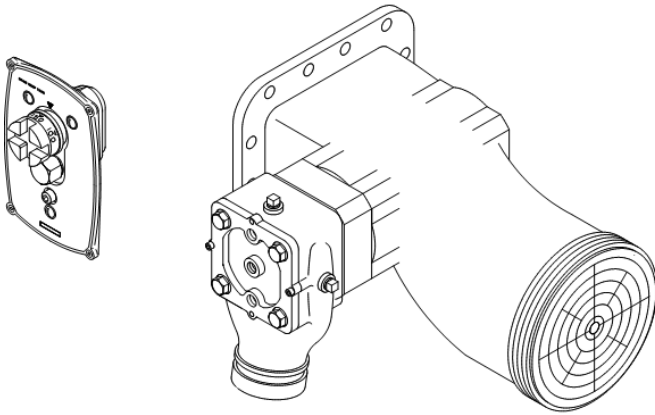

IL3031_2



Read through the installation instructions carefully before installing your Waterous Pressure Control Systems.

WATEROUS

Fire Pumps – Since 1886

Visit us at www.waterousco.com

Waterous Company 125 Hardman Avenue South, South St. Paul, Minnesota 55075 USA (651) 450-5000

Instructions subject to change without notice.

System Description

The Waterous Intake Relief Valve system is designed to act as a safety valve by “dumping” excess pressure from the inlet side of the pump. This makes it less likely that “water hammer” will burst the supply line, and allows the discharge relief valve or governor system to properly control discharge pressure.

The Waterous Intake Relief Valve system incorporates two separate units for flexibility in installation and opera-

tion: the pilot valve and the relief valve. The pilot valve controls operation of the relief valve and can be panel mounted to be easily field adjusted for varying operating conditions (between 50 and 250 psi), or compartment mounted and preset for a specific pressure. It includes a removable strainer and removable needle valve for easy servicing.

Figure 1. Intake Relief Valve System

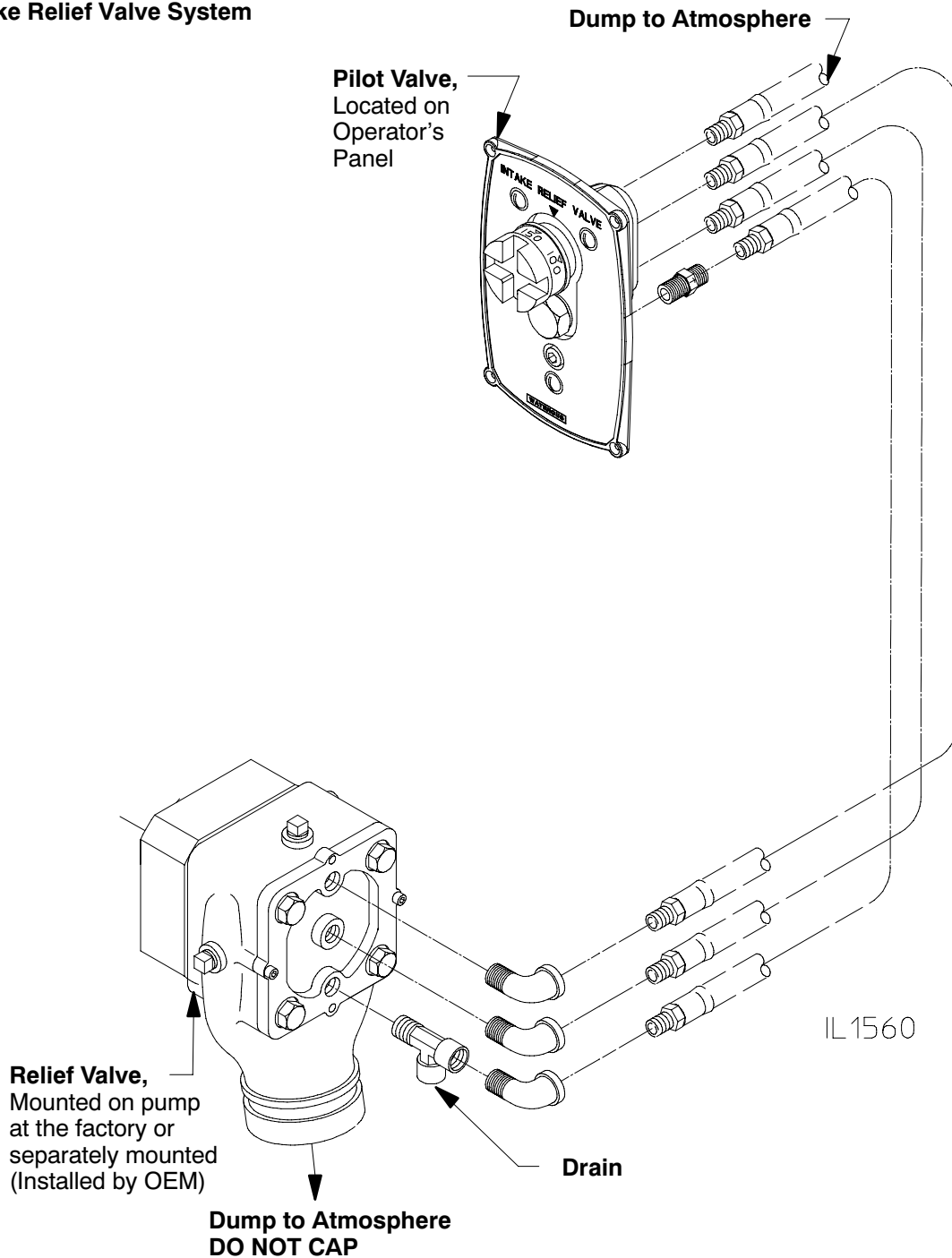

Relief Valve Installation

1. On most Waterous pumps, the relief valve will be installed at the factory. Occasionally the relief valve must be mounted and piped when the pump is installed. Suitable flanges are available from Waterous to install the relief valve in a standard piping system. (See Figure 2).
2. To ensure proper drainage, pilot valve ports (tapped holes) on the relief valve must be located in a vertical line.
3. Attach the relief valve assembly to the tapped flange using four 7/16-14 hex head screws and copper washers.

5. Attach warning plate near the piping outlet. See Page 7.

⚠ WARNING

Tighten these screws to a torque between 30 and 40 lb ft. Failure to properly torque screws may result in leaks.

⚠ WARNING

Do not cap the outlet of the relief valve. This system is designed to hold vacuum while priming and operating from draft.

⚠ DANGER

Intake Pressure Relief Outlet Hazard. Will result in serious injury or death.

Do not cap the intake pressure relief outlet.

A hose is connected to this outlet must be secure to prevent violent movement of the hose during pump operation. Position the hose to aim away apparatus and people.

4. Attach suitable piping to the 2-1/2 inch Victaulic outlet of the relief valve. The piping should be a minimum of 2-1/2 inch I.D. and be firmly attached to the truck.

Figure 2. Separately Mounted Relief Valve

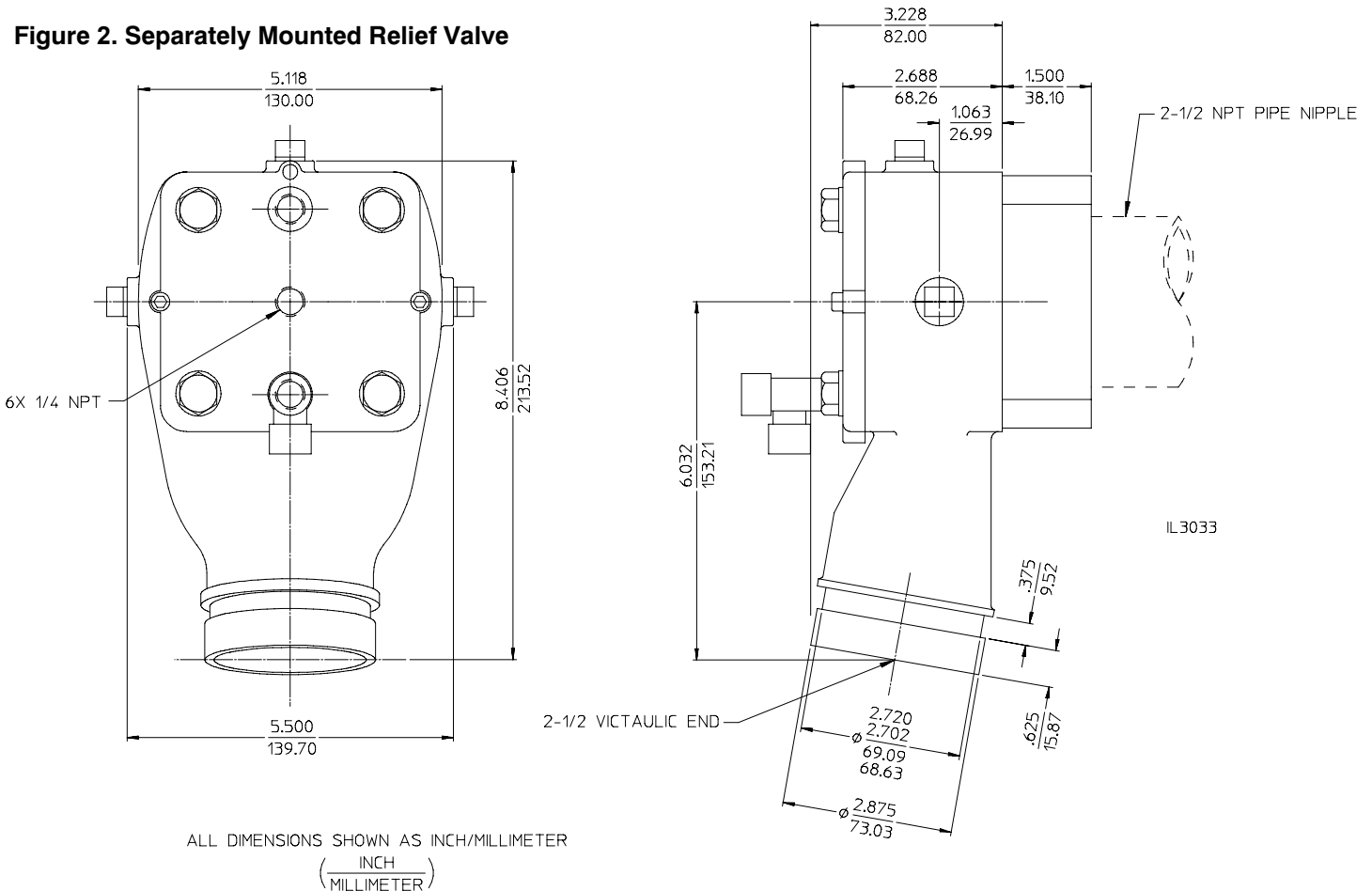

Pilot Valve Installation (See Figure 3)

1. When mounting the pilot valve, choose a location which is higher than the intake relief valve. See Figure 4 for pilot valve dimensions.
2. Position the panel plate on the panel and mark the location of the screw holds. Also, mark the square cut-out (see panel cut-out detail in Figure 3). Deburr all holes and openings in the panel.
3. Rotate the pilot valve control knob fully counter-clockwise.
4. Install the panel plate on the pilot valve by sliding over the control knob. Secure the panel plate to the valve with the (3) screws provided. **Note: Do not remove the set screw on the control knob, the panel plate will slide over the set screw.**
5. Install the Panel/Valve assembly in the panel. Secure to the panel with the (4) screws and nuts provided. Use a thread locking compound on the screws and nuts.

Figure 13. Pilot Valve Installation

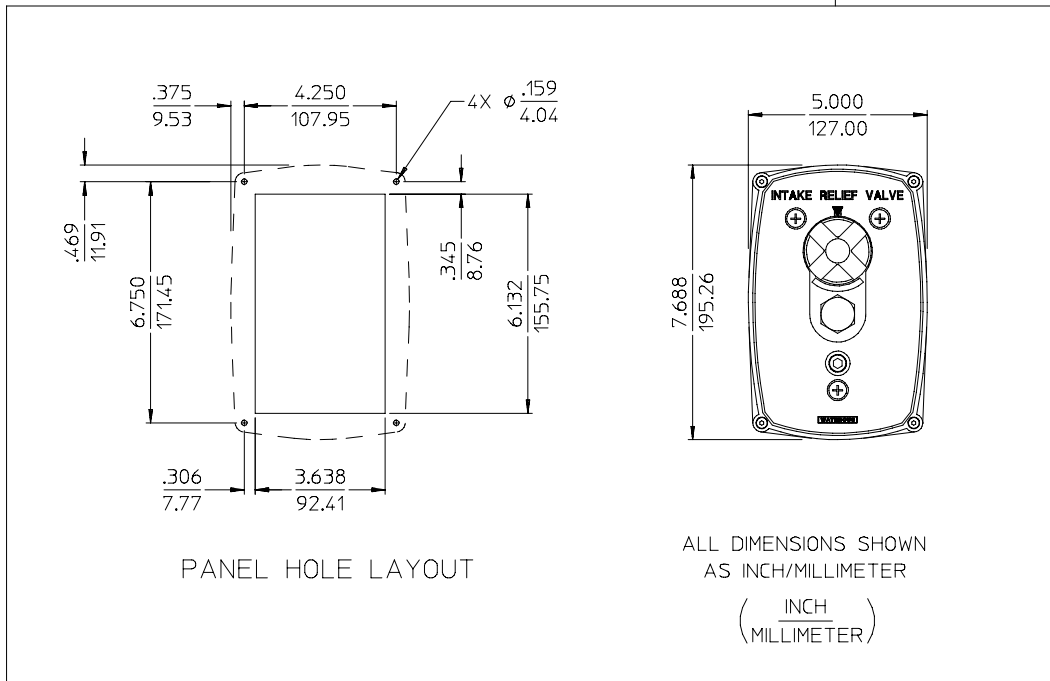
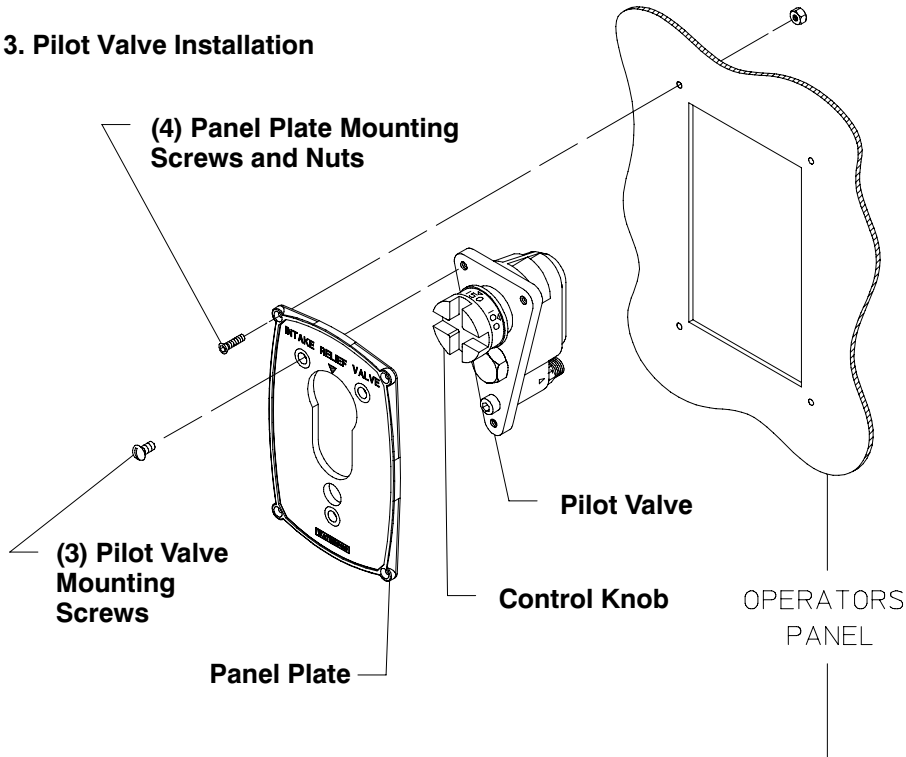

Pilot Valve Installation

Figure 4. Pilot Valve Dimensions

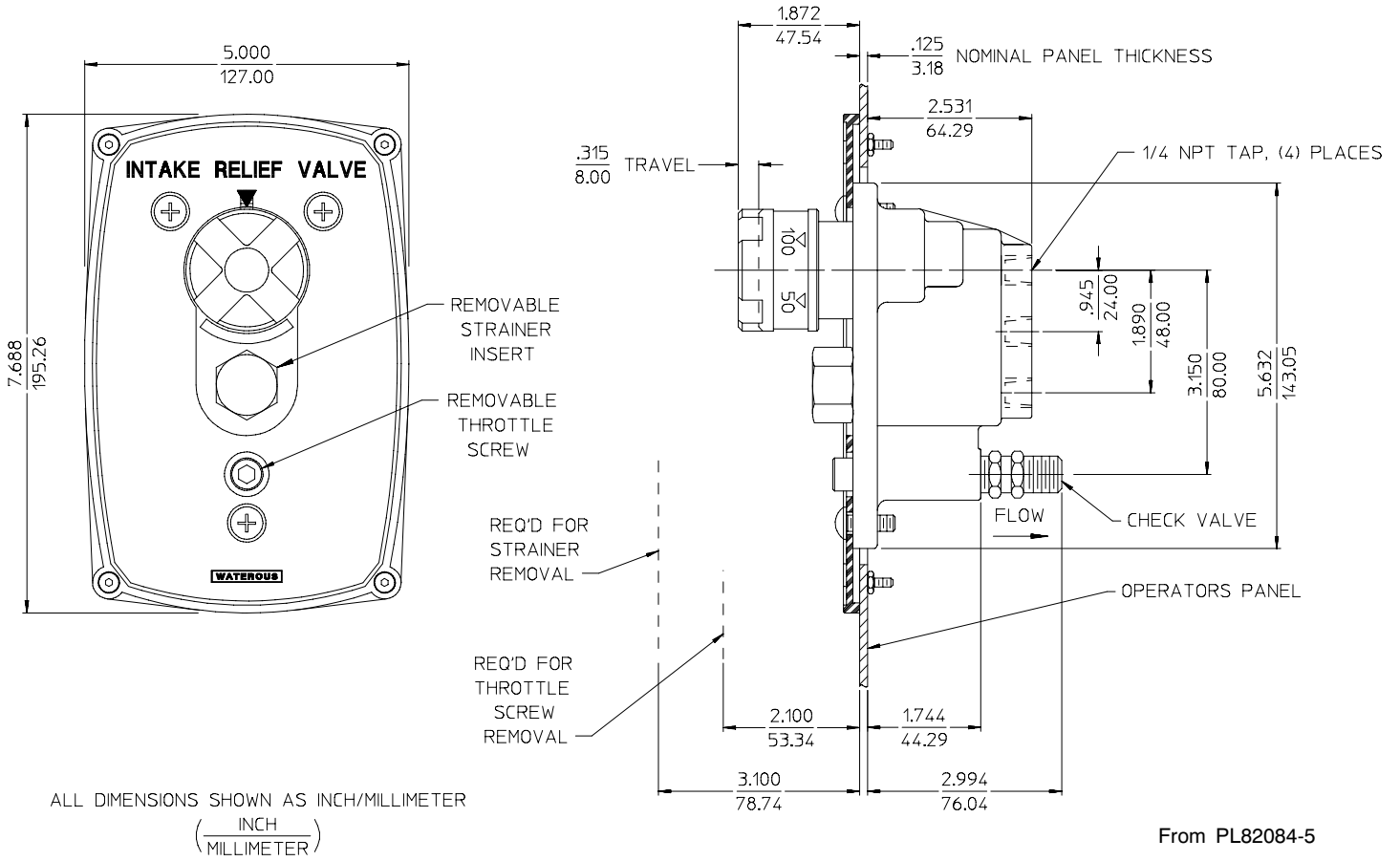

Piping Installation

Use 1/4 inch I.D. tubing for all connections (.188 minimum I.D. through fitting). Excessive pressure surges and erratic operation may result if a smaller size tube is used. Tubing should be rated at 300 psi minimum working pressure and 1400 psi burst pressure. Make sure all lines are free of low spots or sharp bends which will prevent the lines from draining properly.

WARNING

All tubing lines connected to the pilot valve should be dedicated lines. Any pressure fluctuations from devices that may be connected to them will cause the system to malfunction.

1. Connect tubing between the pilot valve and relief valve as shown.

2. Install a drain line from the street tee on the relief valve cover to a separately controlled drain.

WARNING

Do not connect the drain line to a multi-port drain valve.

3. If the relief valve outlet is not facing down for natural draining, install a drain line from the relief valve body to a separately controlled drain.

WARNING

Do not connect the drain line to a multi-port drain valve.

Figure 5. Piping Installation

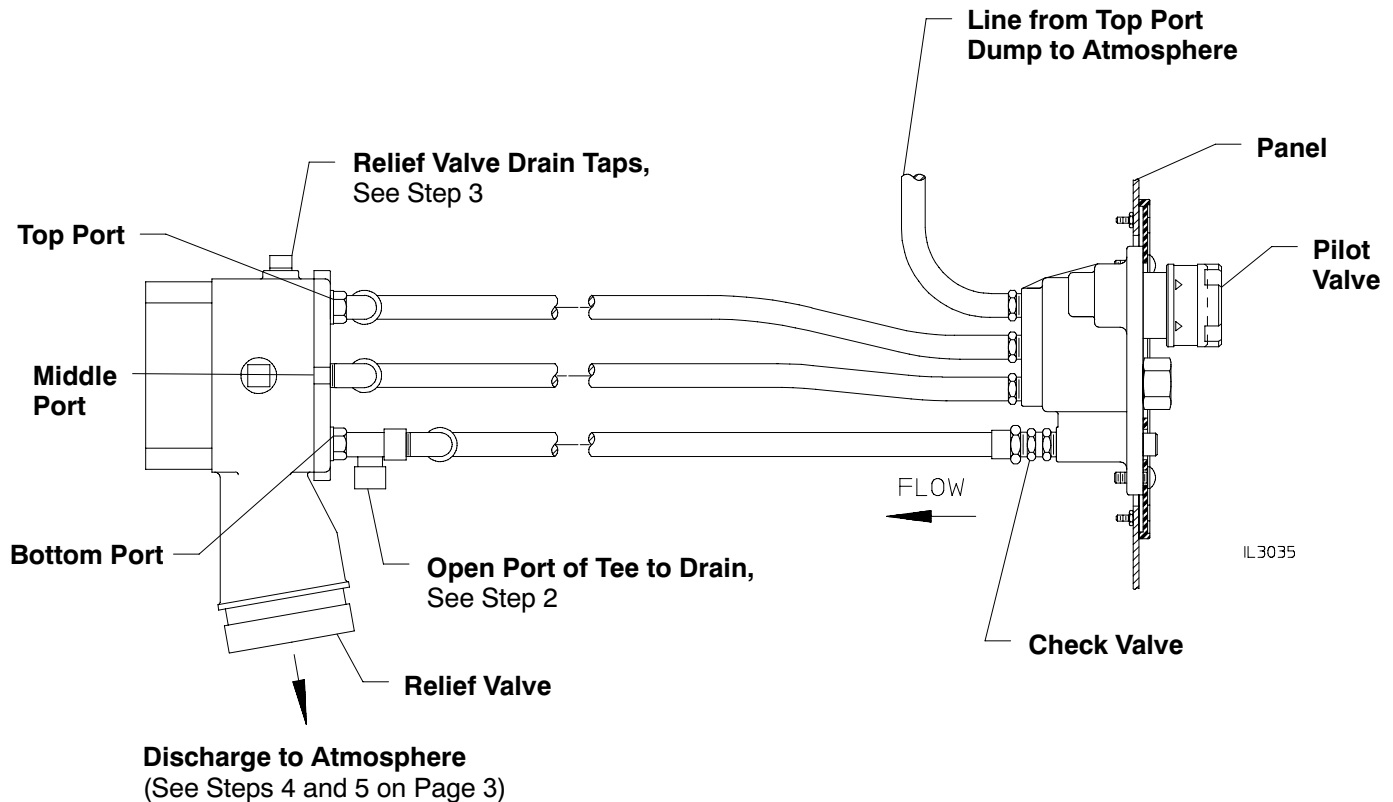

Note: Tubing between relief and pilot valve not furnished by Waterous.

Setting Operating Pressure

1. Test the Intake relief valve system using a pressurized water source capable of supplying continuous flow at 60 to 100 psi.
 - a. Set the pilot valve slightly above the source pressure and apply this pressure to the pump intake. Relief valve should remain closed.
 - b. Reduce pilot valve setting to slightly below source pressure. Relief valve should open, “dumping” a large volume of water.
 - c. Reset pilot valve above source pressure. Relief valve should close.
2. Set final operating pressure by aligning the desired setting on the calibration dial with the arrow on the top of the panel plate. A spanner wrench may be used to move the calibration dial.

Figure 6. Pilot Valve Pressure Setting

