

CZU Series Fire Pumps

Overhaul Instructions

| Form No. | Section | Issue Date | Rev. Date |
|----------|---------|------------|-----------|
| F-1031 | 4221 | 07/29/03 | 1/19/18 |

Table of Contents

Introduction 2

General Overhaul Information

Tools and Equipment 2

Preliminary Testing 2

Cleaning 2

Pump Body and Impellers 2

Bearings, Gaskets, Seals and O-rings 2

Impeller Shaft 2

Installing Ball Bearings 2

End Yoke and Companion Flange Nuts 2

Disassembly

Complete Disassembly of the Pump 3

Mechanical Seal 3

Pumps Built Prior to 2003 3

Pumps Built After 2003

 When Pump is Completely Disassembled 3

 Removing Seal Without Complete Disassembly of Pump 4

Inspection and Repair

Impellers 5

Installing Undersize Wear Rings 5

Impeller Shaft 5

Oil Seal Sleeve 5

Volute Body and Intake Adapter 5

Reassembly

Volute Body, Intake Adapter and Impeller Shaft 6, 7

Mechanical Seal

Pumps Built Prior to 2003 8

Pumps Built After 2003 9, 10

Final Assembly 11

Testing

Hydrostatic Testing 11

Operational Testing 11

Illustrations

Figures:

1. Removing Mechanical Seal Using Small Pry Bars 4
2. Mechanical Seal Lubricant Application 8
3. Mechanical Seal Installation Prior to 2003 10

Tables

Tables:

1. Impeller and Wear Ring Repair Dimensions 5

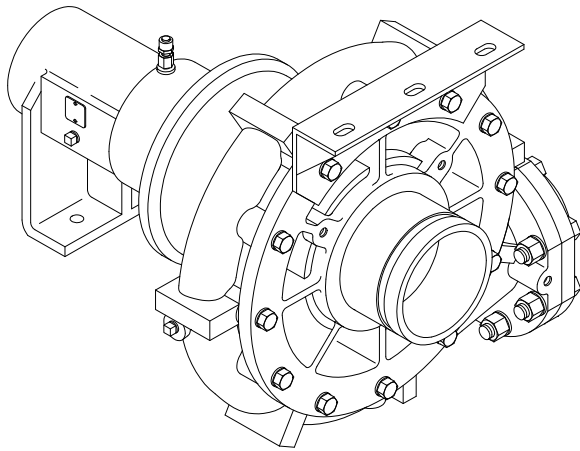

Introduction

This instruction contains the information needed to overhaul and repair Waterous CZU series centrifugal fire pumps.

The text uses reference numbers when discussing specific parts. These numbers refer to the parts called out on the Service Parts List which is supplied with the pump.

General Overhaul Information

Tools and Equipment

The following tools and equipment are needed to overhaul a pump:

1. Usual automotive mechanic's hand tools.
2. An arbor press for assembling or disassembling components.
3. An engine lathe for turning impeller hubs.
4. A suitable hoist and slings.
5. Torque capability up to 325 lb-ft.

While no special tools and equipment are required, a few special items are illustrated or described so the mechanic can make them or they are available from the apparatus manufacturer or the Waterous Company. These special items are not absolutely necessary, but they will make the mechanic's work much easier.

Preliminary Testing

Before disassembling a pump, test it thoroughly, if possible, and record the results. A comparison of this test with periodic tests recommended in form F-1031, Section 1000 can often reveal specific pump troubles. Excessive speed, for instance, indicates that impellers and/or wear rings are probably worn.

Cleaning

The continued satisfactory operation of a pump depends to a great extent upon the cleanliness of its internal parts. Sand, dirt or other abrasive material will wear bearings, gears and related parts. Before disassembling a pump for repairs, be sure to clean its exterior. Make sure the working space, benches and tools are clean. Use only clean, lint-free cloths to wipe off components. Before reassembling a pump or its components, be sure to clean them thoroughly.

Pump Bodies and Impellers

Flush out these components and related parts with clean water. Use a stiff brush to remove loose scale, caked sediment, etc. Be sure to remove all traces of old gaskets. Examine pump bodies, covers, adapters and fittings for cracks, severe corrosion or other damage. Almost all damage to these parts results from improper use or maintenance, or from freezing. Replace defective parts.

Bearings, Gaskets, Seals and O-rings

Parts of this nature are frequently damaged during removal or disassembly. In addition, they sometimes deteriorate or lose their effectiveness because of age or misuse. Replacing these parts whenever overhauling a pump is a good policy.

Impeller Shafts

Examine shaft for severe scratches, grooves or corrosion – especially under packing or mechanical seals. If scratches are not severe, and are not under packing and seals, clean them with a fine-cut file. Grooves are usually permissible if they are not sharp or too deep. Even slight longitudinal scratches will cause leaks and should be removed.

Installing Ball Bearings

Most Waterous pumps are designed so that ball bearings fit tightly on their shafts and have relatively loose fits in the bearing housings. When mounting these bearings on shafts, always apply force to the inner races. When bearings have a tight fit in the housings, and a heavy force is necessary to install them, be sure to apply force only to the outer bearing races. For either type of fit, applying force to the wrong bearing race may damage the balls and race.

End Yoke and Companion Flange Nuts

Do not reuse self-locking nuts. Apply lubrication to the threads before removing. Apply anti-seize to the threads before installing a new self-locking nut.

Complete Disassembly of Pump

Refer to the appropriate pump body and impeller shaft service parts list for reference numbers.

NOTE: The wear rings (S3) in the volute body (B1) and intake adapters (B2) cannot be removed without ruining them. They should only be removed if new wear rings are required.

1. Remove hex hd screws (B14) that attach discharge adapter (B13) to volute body (B1). Remove O-ring (B17) from discharge adapter and discard.
2. Remove screws (B5) that attach intake adapter (B2) to volute body. Remove O-ring (B9) from the intake adapter and discard.
3. Remove cotter pin (S10 or S17) impeller nut (S4) and impeller washer (S7).
4. Remove and discard O-rings (S20) and (S21) on the impeller shaft.
5. Remove impeller (S1) from impeller shaft (S2). Tapping the impeller lightly with a soft hammer may be necessary to free it from the impeller shaft so it can be removed. There are 5/16-18 NC tapped holes in the impeller to allow use of a puller if necessary.
6. Pry the mechanical seal stationary ring out of the impeller with a screw driver.

NOTE: Pumps Built After 2003 – It is not necessary to remove the stainless steel collar from the impeller.

NOTE: Pumps built after 2003 may have the mechanical seal removed without completely disassembling the pump. See Page 4.

7. Stand the pump in a vertical position, resting it on the face of the volute body.
8. Remove screws (B5) fastening the bearing housing (B3) to the volute body. Tap the bearing housing lightly with a soft hammer to free it from the volute body.
9. Rig a sling to the end yoke that is attached to the impeller shaft. With a hoist, lift the shaft and the housing from the body. The impeller shaft should come out of the mechanical seal since they are not in contact with each other.

10. Remove the O-ring (B6) from the groove in the face of the bearing housing and discard.
11. With the shaft and bearing housing detached from the hoist, remove cotter pin (S10), shaft nut or the self-locking nut (S8) and flat washer (S13) that attach the yoke to the impeller shaft. Do not reuse self-locking nut. Apply lubricating oil to the threads before moving.
12. Remove the end yoke from the impeller shaft.
13. Slide the bearing housing off the ball bearings (S15 & S16) on the impeller shaft. Remove the breather (B4), snubber (B12), pipe plugs (B8) and oil seal (S11) from the bearing housing.
14. Position the impeller shaft assembly in a vertical position in an arbor press with the spline end of the shaft up and the impeller end of the inner race of the bearing (S15) supported by the table of the press. Press the shaft out of the bearings (S15 & S16), bearing spacer (S5) and oil seal sleeve (S6).

CAUTION

When the shaft is free of bearing (S15) it will fall free. Blocking should be provided under the shaft.

15. With a brass drift pin, tap the mechanical seal ring out of the volute body.
16. Remove the oil seal (S12) and pipe plug (B8, B15 or B19) from the volute body.
17. If the wear rings (S3) in the volute body and the intake adapter are to be replaced they must be driven out of the body or adapter.

Mechanical Seal Removal Only Without Disassembling the Pump

Pumps Built from 2003 to Present Only

If the mechanical seal is the only item that needs to be replaced, the seal can be removed from the volute by using a pair of small pry bars as shown in Figure 2 inset (not supplied by Waterous). Using this technique, the volute does not have to be removed from the bearing housing due to the seal stationary ring nesting in the impeller. Prior to 2003, the seal stationary ring nested in the bottom of the volute bore.

1. Follow Steps 1 through 6 of the Disassembly instructions on Page 2.
2. Using two small pry bars, remove the mechanical seal from the impeller shaft.
3. Remove O-ring (S19) and discard.

Figure 1. Removing the Mechanical Seal Using Pry Bars

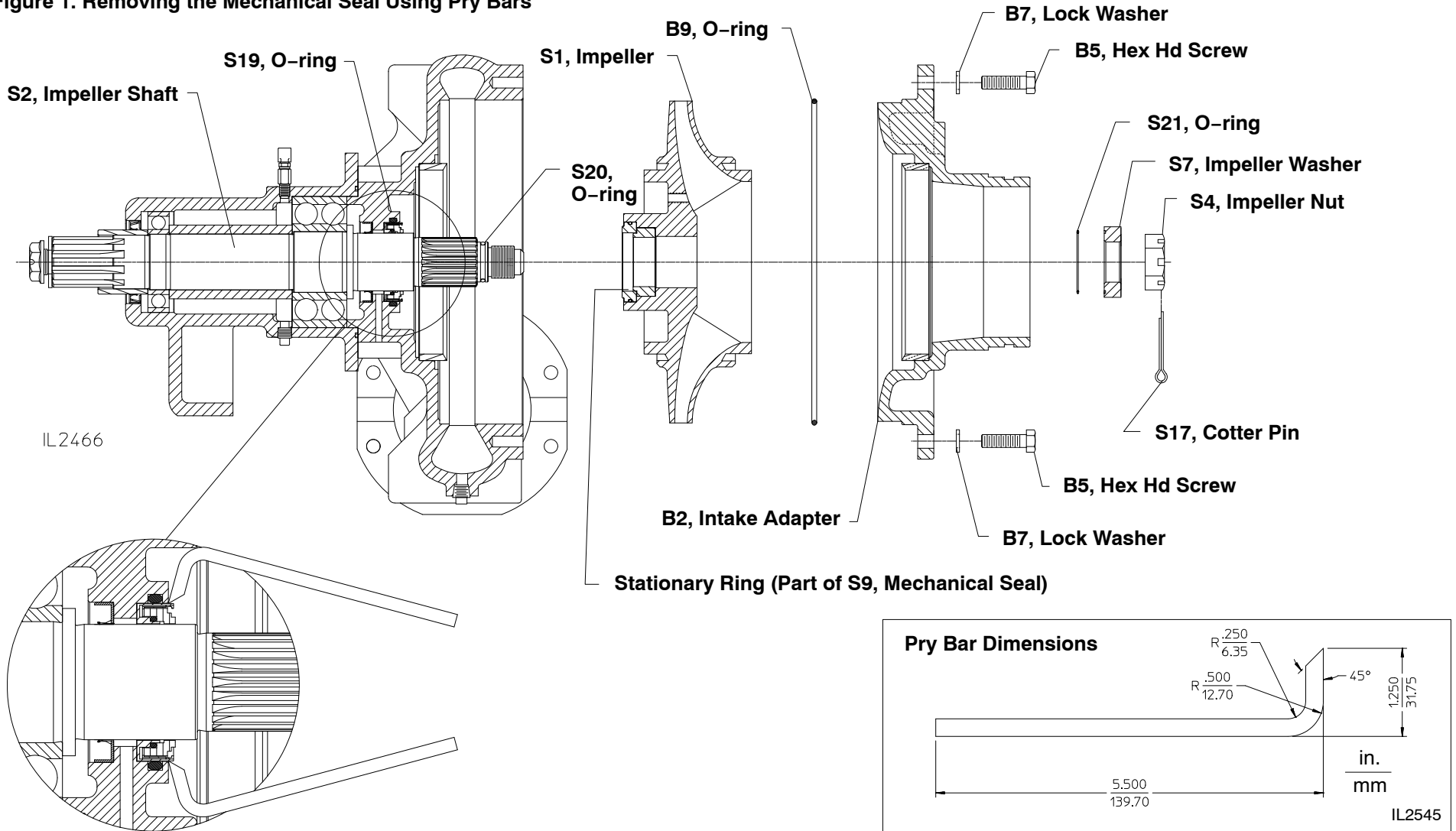

Inspection and Repair

Impeller

Check wear rings and impeller hubs for deep grooves or scratches. Spiral grooves or grooves parallel to the impeller shaft increase leakage. Inspect for excessive wear ring clearance. Diametric clearances in excess of .027 inches may warrant wear ring replacement. Original factory clearance is .019 to .023 diametrically. The diametric clearance should be determined by averaging the results of four measurements taken at 90 degree increments as follows:

Clean and remove small burrs or other protrusions from the wear ring inner diameters and the impeller hub O.D. and I.D. Position each wear ring on the impeller hub on which it was used. Hold the wear ring firmly against one side of the hub and measure total clearance on the opposite side, using a feeler gauge. Do not bottom the wear ring against the bottom of the groove in the impeller.

Table 1. Impeller and Wear Ring Repair Dimensions

| Impeller No. | Original Hub Dia. | Original Wear Ring No. | Reworked Hub Dia. | New Wear Ring No. |
|--------------|-------------------|------------------------|---|----------------------------------|
| 82574 | 7.151/7.149 | 72416 | 7.126/7.124 7.101/7.099 7.076/7.074 | 72416-25 72416-50 72416-75 |

Keep the hub diameters within 0.015 in. TIR of the impeller shaft bore. If the impeller hubs do not clean up at first undersize dimension, turn the hub down to the next degree of undersize. Replace the impeller if the hubs do not clean up at the last undersize dimension.

Impeller Shaft

Examine shaft for signs of severe scratches, grooves or corrosion. If scratches are not severe, and are not under seals, they can be ignored. Check for cracks, pitting, twisted splines or damaged keyway.

Installing Undersize Wear Rings

Replacement wear rings are available as follows:

- 0.025 in. undersize
- 0.050 in. undersize
- 0.075 in. undersize

If inspection shows that the wear ring clearances are excessive or the impeller hubs are scored or grooved, turn the impeller hub on a lathe to an acceptable dimension. Table 1. shows the original hub dimensions for each impeller and the rework dimensions for each degree of undersize.

NOTE: Wear rings may be removed by crisscrossing two pry bars under opposite sides of the wear ring. Pry up the wear ring by applying equal pressure to both pry bars.

Oil Seal Sleeve

Check for wear and scratches where the seal contacts the sleeve. The journal may be polished with a fine emery cloth, however; any polishing that leaves a spiral pattern may lead to an oil leak. If a groove has been worn in the sleeve, it can be reused by turning it end for end. If questionable, replace the sleeve.

Volute Body and Intake Adapter

Examine these for cracks, severe corrosion or other damage. Almost all damage to these parts results from improper use or maintenance, or from freezing. Replace defective parts.

Clean out drainage hole in volute body, located between the seat for the oil seal and stationary seal ring of the mechanical seal.

Reassembly

NOTE: These instructions are written based on installation of new wear rings, either standard size or under size. The wear ring hubs on the impeller are sized to suit.

1. Slide both wear rings (S3) onto the impeller (S1) with the tapered (concave) end towards the impeller. With the inner wear ring overhanging the impeller by 1/4 inch there should be radial shake between the wear ring and impeller. Similar radial shake should exist between the outer wear ring and impeller with the wear ring overhanging the impeller by 1/8 inch. Do not bottom the wear rings with the impeller when checking for radial shake.
2. Inspect the bore for the wear ring in the intake adapter and volute body for any raised burrs or nicks that may have occurred when removing the old wear rings. Remove any burrs or nicks before installing new wear rings.
3. Position the intake adapter (B2) on a bench with the bore for the wear ring facing up. Position the wear ring in the bore with the square end down. Apply Loctite 609 to assist in wear ring retention. With a soft hammer, begin seating the ring squarely into the bore and then drive it down by hitting it evenly from side to side until it bottoms against the shoulder at the bottom of the bore.
4. Install the wear ring in the volute body (B1) the same way as that installed in the intake adapter.
5. Install oil seal (S12) in the volute body. Make sure the lip of the seal is facing toward the bearing housing (B3).
6. Support bearing (S15) on the face of the inner race and press the impeller shaft (S2) yoke spline end first thru the bearing until the shoulder on the shaft is tight against the bearing.
7. Slide spacer (S5) on the shaft, against the bearing (S15). Press bearing (S16) onto shaft, tight up against the spacer. Press oil seal sleeve (S6) onto the shaft, tight up against bearing (S16).
8. Position the volute body on the bench, resting it on the face the intake adapter bolts to.
9. Take the previously assembled shaft and temporarily install the end yoke and secure it with the shaft nut (S8). Finger tighten only.
10. Secure a sling to the end yoke and lift the shaft until it hangs vertically above the volute body.
11. Align the shaft with the oil seal in the volute body and slowly lower the shaft through the oil seal in the body until the outer race of bearing (S15) seats against the hub on the body.

CAUTION

As the journal on the shaft for the oil seal begins to enter the oil seal, make sure the seal lip does not turn under or the garter spring in the seal does not pop out of position.

12. Remove the shaft nut and the end yoke from the shaft.
13. Install the oil seal (S11) in the end of the bearing housing with the seal lip towards the inside of the housing.
14. Apply a light film of grease in the groove in the face of the bearing housing. Install O-ring (B6) in this groove.
15. Position the bearing housing over the shaft, rotating it to its correct relation to the volute body. Slide it down over bearings (S15) and (S16) until it seats against the volute body. Line up holes and install screws and lock washers (B5) and (B7), torque to 45 Lb.Ft.
16. Reassembly of the bearing housing and impeller shaft to the volute body should restore alignment to each other. To check the alignment, attach an indicator to the impeller shaft and rotate the shaft and indicate the bore in the volute body. The runout should be within .005 T.I.R. If the runout exceeds this, the following should be checked:
 - Raised burr or nick on faces of the bolted joint between the bearing housing and volute body.
 - Foreign material caught between the joint.
 - O-ring out of position and pinched between the joint.
17. Temporarily install the impeller and rotate the impeller shaft. The impeller should rotate without contact with the wear ring in the volute body. Remove the impeller.
18. Install mechanical seal:
 - Pumps built prior to 2003: See page 8.
 - Pumps built after 2003: see page 9.
19. Grease O-ring (B9) and install on the intake adapter.
20. Position the intake adapter to the volute body. Line up holes and tap the adapter down into position. Install screws and lockwashers (B5) and (B7). Tighten until the surface of the adapter meets the surface of the volute body. Rotate the impeller shaft. Make sure the wear rings and the impeller are not rubbing against each other.
21. If the impeller turns freely, tighten screws evenly from side to side. Torque to 45 lb.ft.

Reassembly

22. If the impeller rubs against the wear rings, remove the adapter and determine the cause. The following can cause rubbing:

- a) Raised burr or nick on either the hub of the impeller or on the wear ring.
- b) Wear ring cocked when installed and is deformed sufficiently to rub on the impeller.
- c) Impeller hub was not reworked to correct size for use with new undersize wear ring.

NOTE: To protect the rubber bellows of the mechanical seal, place a piece of masking tape over the keyway on the impeller shaft, making sure that the tape is able to be removed after bellows has passed over the keyway.

- a. Lubricate O-rings (S20) and (S21) with grease and put them on the shaft and washer. Install the washer and impeller nut onto the impeller shaft.

NOTE: The CZU impeller nut is a left-hand nut.

23. Install and secure cotter pin (S17).

24. Grease O-ring (B9) and install on the intake adapter.

25. Position the intake adapter to the volute body. Line up holes and tap the adapter down into position. Install screws and lockwashers (B5) and (B7). Tighten until the surface of the adapter meets the surface of the volute body. Rotate the impeller shaft. Make sure the wear rings and the impeller are not rubbing against each other.

26. If the impeller turns freely, tighten screws evenly from side to side. Torque to 45 lb.ft.

27. If the impeller rubs against the wear rings, remove the adapter and determine the cause. The following can cause rubbing:

- a) Raised burr or nick on either the hub of the impeller or on the wear ring.
- b) Wear ring cocked when installed and is deformed sufficiently to rub on the impeller.
- c) Impeller hub not reworked to correct size for use with new undersize wear ring.

28. After correcting the problem of rubbing between the impeller and wear rings, reinstall the intake adapter.

29. Grease O-ring (B17) and install on the discharge adapter (B13). Position discharge adapter to volute body. Install screws (B14).

30. Install pipe plug (B8, B15 or B19) in the volute body.

31. Install the two pipe plugs (B8) in the bearing housing. Install the snubber (B12) in the upper hole in the housing and then the breather (B4) into the snubber.

32. Place the end yoke on the impeller shaft. Install flat washer (S13) and shaft nut (S8). Anti-seize should be applied to the threads before installing a self-locking nut. Do not reuse self-locking nuts. Torque to 400-450 lb-ft.

Mechanical Seal Installation

Pumps Built Prior to 2003 (Keyed Impeller)

NOTE: Clean sealing surfaces with denatured alcohol and a clean, soft cloth before assembly.

CAUTION

The mechanical seal primary and stationary rings are made of brittle material. The material can be cracked or chipped. Extra care must be taken when handling these rings.

NOTE: If Waterous Mechanical Seal Lubricant part no. 52608 is not available, P80 rubber lubricant, straight dish soap or glycerin may be substituted.

- a. Apply a light coating of seal lubricant to the O-ring in the stationary seal ring of the mechanical seal (S9).
Note: To protect the rubber bellows of the mechanical seal, place a piece of masking tape over the keyway on the impeller shaft, making sure that the tape is able to be removed after bellows has passed over the keyway.
- b. Slip the seal ring over the end of the impeller shaft, with the finish lapped face of the seal ring facing up (the opposite side of a new seal ring has a mark on it). Slide it along the shaft and push it into and seat it in the bore in the volute body. If it can not be pushed in by hand it may be tapped into place by use of a block of wood between the ring and a hammer.
- c. Wipe the face of the previously installed stationary seal ring of the mechanical seal with a clean lint free cloth or tissue paper.
- d. Wipe a few drops of seal lubricant on the inside of the bellows of the mechanical seal and wipe the face of the carbon ring with a lint free cloth or tissue paper. Slide the seal onto the shaft until the carbon ring contacts the stationary seal ring.
- e. Install the spring over the seal assembly
- f. Install key (S14) in the impeller shaft and then install the impeller, plain washer (S7) and impeller nut (S4) and snug up the nut. Rotate the impeller to assure seating of the mechanical seal spring into the counterbore on the backside of the impeller. If the spring is not properly seated it will snap into place when the impeller is rotated.
- g. Tighten impeller nut and line up slot in the nut with the hole in the shaft. Install and secure cotter pin (S10 or S17).

Figure 2. Mechanical Seal Lubricant Application

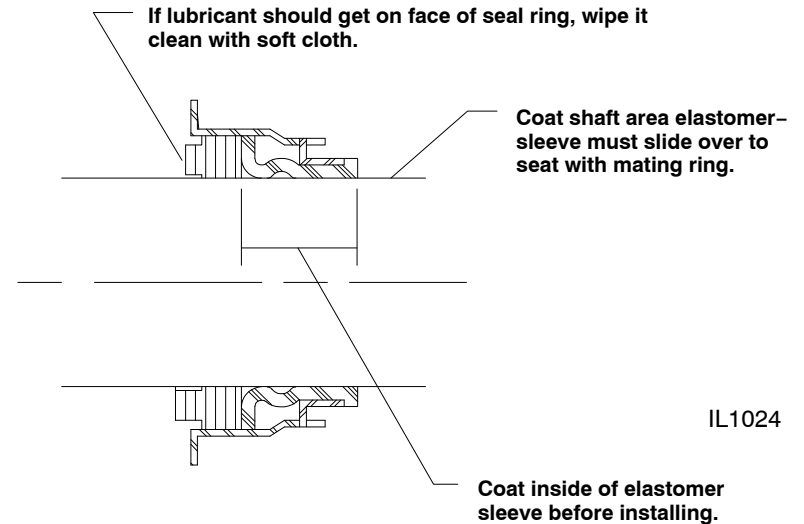

Mechanical Seal Installation

Pumps Built Prior to 2003 (Keyed Impeller)

NOTE: Clean sealing surfaces with denatured alcohol and a clean, soft cloth before assembly.

CAUTION

The mechanical seal primary and stationary rings are made of brittle material. The material can be cracked or chipped. Extra care must be taken when handling these rings.

NOTE: If Waterous Mechanical Seal Lubricant part no. 52608 is not available, P80 rubber lubricant, straight dish soap or glycerin may be substituted.

- a. Apply a light coat of grease on O-ring (S19) and seal lubricant to the bore in the volute body. With the help of a rag or tissue, press and seat the mechanical seal ring into the volute body.
- b. Apply a light coat of mechanical seal lubricant to the O-ring in the mating seal ring and the bore in the impeller. With the help of a rag or tissue, press it into the impeller. Install impeller.
- c. Install O-ring (S20) on the impeller shaft and coat with grease.
- d. Install O-ring (S21) in the impeller washer and coat with grease.
- e. Install impeller, washer and nut. Note that impeller nut thread is left hand.
- f. Install cotter pin in impeller nut.

Mechanical Seal Installation

Pumps Built Prior to 2003 (Continued)

Figure 3. Mechanical Seal Installation Prior to 2003.

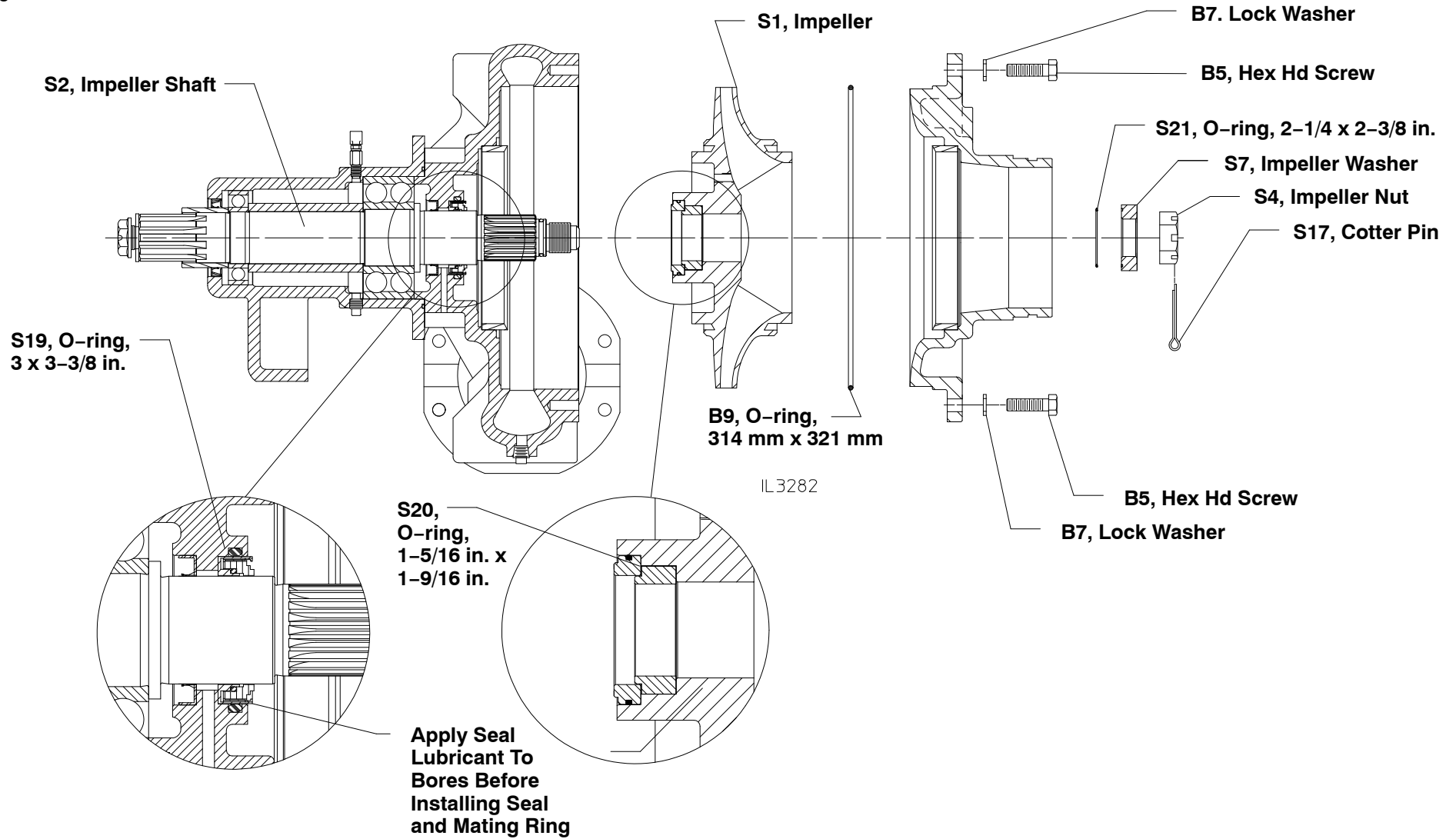

Final Assembly

To complete final assembly, perform the following:

1. Connect the intake and discharge piping.
2. Connect the cooling and drain lines, electrical wiring and similar equipment to the pump and accessories.
3. Remove filler plug or breather on the bearing housing, and pour fluid through the opening. Fill to bottom thread of oil level hole. *Do not overfill.* Use non-detergent SAE 30 oil.

Testing

Before a pump can be returned to service, it is advisable to give the pump a hydrostatic and operational tests to check it for leaks and to make sure the pump operates properly.

Hydrostatic Testing

1. Connect the pump to a hydrant or other pressurized water supply.
2. Close all drain lines and open the discharge and priming valves.
3. Open hydrant until the water runs out through the discharge valves and discharge pipe in priming pump (if used).
4. Close all valves. Be sure to evacuate all air from the pump.
5. Check for leaks with a portable light. If leaks are discovered, tighten connections or attaching parts as necessary. Repeat until all leaks are eliminated.

NOTE: If a mechanical seal is used, the seal may leak under hydrostatic pressure; however, it should stop leaking after the seal faces are run in during operational testing.

6. Shut hydrant valve after all leaks are eliminated.
7. Drain pump completely and disconnect intake hose.

Operational Testing

1. Operate the pump at its maximum intended service pressure. (Refer to NFPA 1911).
2. Check for leaks with a portable light. If leaks are discovered, stop the pump and tighten connections or tighten attaching parts as necessary. Repeat until all leaks are eliminated.
3. Check for unusual noises, oil leaks, overheated bearings, etc. while the pump is running. If anything unusual is discovered, stop the pump immediately and determine the cause of the problem.