



Fire Pump Models CZ and CZU Installation Instructions

Waterous Fire Pumps may be ordered with a variety of accessories.
Refer to the following separate installation instructions as necessary:

- Auto Tank Fill System
- Butterfly Valves
- CAF System
- Discharge Valves
- Drain Valves
- Foam System:
 - Foam Pump
 - Foam Pump Flush Kit
 - Foam Fill
 - Dual Foam Injection Kit
 - Dual Tank Selector
 - Overboard Foam Pick-up
 - Remote Start Kit
- Overheat Protection Manager (OPM)
- Pump Shift (Pneumatic)
- Pressure Control System:
 - Discharge Relief Valve
 - Intake Relief Valve
 - Pressure Governor
- Priming System



Read through safety information and installation instructions carefully before installing your Waterous Fire Pump.

Note that Instructions are subject to change without notice.

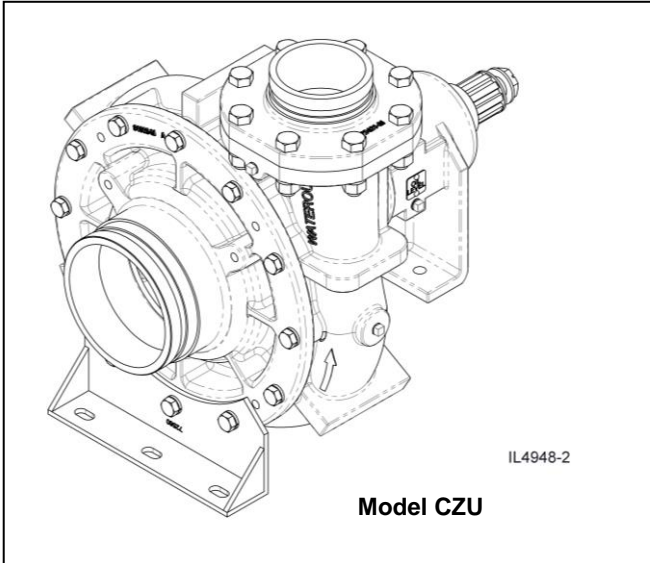
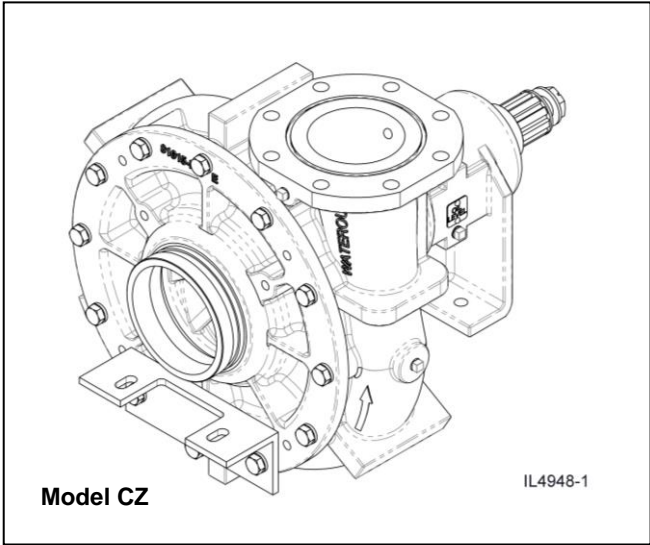

F-2883
Issued: 1/4/21

Table of Contents:

Safety Information	3
Pump Intake and Discharge Connections	4
Available Pump Drives	4
Pump Mounting	4
Mounting Locations and Clearances Required for Maintenance:	
Model CZ.....	5
Model CZU.....	6
Optional Corrosion Protection	7
Final Checks:	
Lubrication.....	8
Testing.....	8



Read through and communicate safety information to the end user of this Waterous Fire Pump.

 **WARNING**

Death or serious personal injury might occur if proper operating procedures are not followed. The pump operator, as well as individuals connecting supply or discharge hoses to the apparatus must be familiar with these pump operating instructions as well as other operating instructions and manuals for the apparatus, water hydraulics and component limitation.

 **WARNING**

Pressure Hazard. May result in personal injury.

Prior to connection or removal of hoses, caps or other closures with pump intake or pump discharge connections, relieve pressure by opening drains or bleeder valves. Bleeder valves should also be used while filling a hose connected to an intake with water.

 **WARNING**

Scalding Water Hazard. May result in serious burns.

When operating the pump, be sure to open at least one discharge valve slightly to prevent the pump from overheating. If the pump runs for a few minutes completely closed, it may heat the water enough to scald someone when the valve is opened. Overheating can damage the packing, seals and other pump parts. If the apparatus builder has installed a by-pass system or other provision designed to prevent overheating, opening a discharge valve may be unnecessary.

 **WARNING**

Rotating Parts Hazard or Unexpected Truck Movement. May result in serious personal injury or death.

Stop the engine, set parking brake and chock the wheels before going under the truck to adjust packing or to check packing gland temperature.

OEM Installation Warnings

 **WARNING**

Unexpected Truck Movement. May result in serious personal injury or death.

Failure to properly install the pump shift control and pump shift indicator system in the apparatus or failure to incorporate in the Pump Operator's Panel Engine Speed Interlock System may result in unexpected truck movement which may result in serious personal injury or death.

 **WARNING**

Inability to Pump Water. May result in serious personal injury or death.

Failure to properly install the pump shift control and pump shift indicator system in the apparatus or failure to incorporate in the Pump Operator's Panel Engine Speed Interlock System may result in the inability to pump water which may result in serious personal injury or death.

 **WARNING**

Exceeding Power Train Torque Ratings. May result in inability to pump water causing serious personal injury or death.

This fire pump may have the capability under certain pumping conditions to exceed the torque rating of the power train.

A means to control the engine output to a torque level no greater than the power train's continuous-duty torque rating must be considered when specifying power train components and engine control system parameters.

Pump Intake and Discharge Connections

Pump Model	Intake	Discharge
CZ	5 in. Victaulic®	4 in. ANSI Flange
CZU	6 in. Victaulic®	4 in. Victaulic®

Available Pump Drives

Drive	Transmission				Complete Pump and Transmission Model
	Type	Series	Model	Input Shaft Rotation	
PTO	None, Direct Drive from PTO	D	D	Clockwise or Counter Clockwise	CZ, CZU

Pump Mounting

Select a mounting location which will make the pump and its accessories readily accessible for maintenance and which will make the pump driveshaft parallel with the output shaft of the chassis transmission or transfer case. Also, select the location so that when the apparatus is loaded, the universal joints on the propeller shaft will have a proper working angle. Be sure the propeller shaft used are of the slip-joint design. Frame deflection, temperature changes and similar factors may cause a propeller shaft without slip-joints to produce severe axial loads on the bearings and damage the pump.

Be sure to keep at least a minimum of 1° U-joint operating angle. This is the preferred method of propeller shaft installation. For additional information on this method, or for alternative methods, see driveshaft installation guidelines such as Spicer®/Driveshaft Installation Techniques.

Driveline End Yokes and Companion Flanges: Anti seize should be applied to the shaft threads before installing end yoke or companion flange. Use self-locking nuts supplied, torque to 400-450 lb-ft. Do not re-use nuts if end yoke or companion flange is removed.

Brackets must be fabricated to attach to the mounting points of the pump body and transmission and the chassis frame. Tighten the mounting hardware to standard torque specifications.

Mounting Locations

Model CZ

Note that the Pump Discharge may be positioned Horizontal or Vertical. The intake side mounting bracket may be positioned Vertical or Inverted. The mounting flange on the bearing housing may be positioned Vertical or Inverted. Refer to the configuration of the pump you ordered and pump dimensional drawing for details specific to your pump.

Anti-seize should be applied to the shaft threads before installing end yoke or companion flange. Do not reuse self-locking nuts. Torque to 400-450lb-ft.

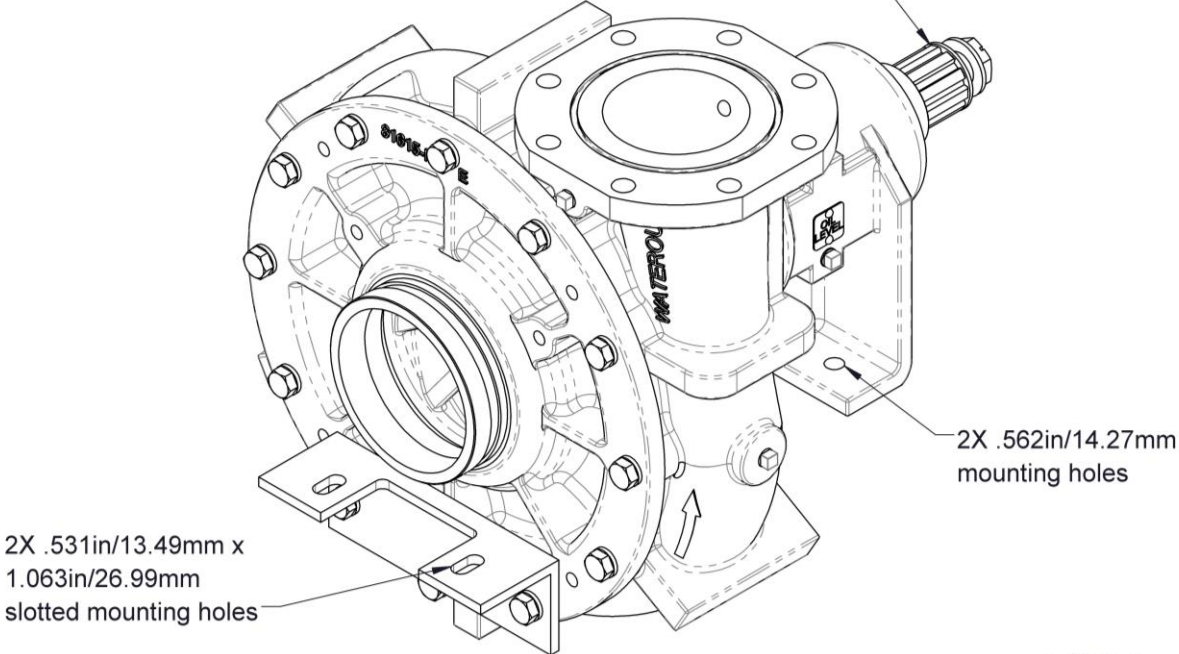

Mounting Locations

Model CZU

Note that the Pump Discharge may be positioned Horizontal or Vertical. The intake side mounting bracket may be positioned Vertical or Inverted. The mounting flange on the bearing housing may be positioned Vertical or Inverted. Refer to the configuration of the pump you ordered and pump dimensional drawing for details specific to your pump.

Anti-seize should be applied to the shaft threads before installing end yoke or companion flange. Do not reuse self-locking nuts. Torque to 400-450lb-ft.

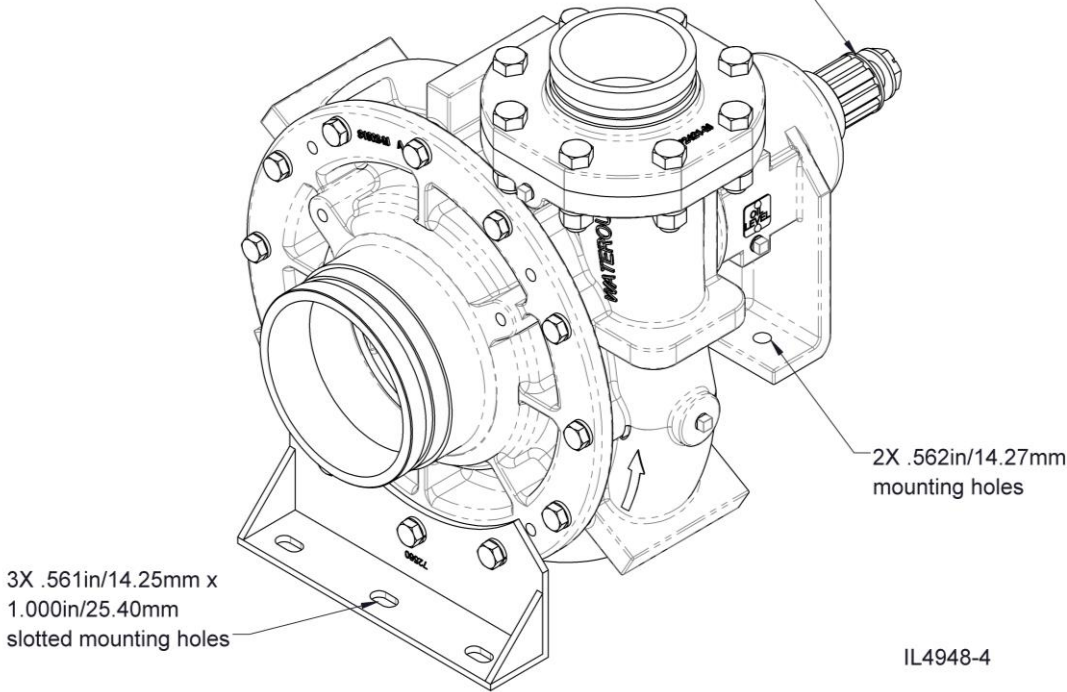

Optional Corrosion Protection

Intake Screens

Waterous offers intake screens that fit 4, 4-1/2, 5 and 6 inch intake fittings sizes. The screen is designed to fit in the counter bore in the inside diameter of the fittings. There must be a strong electrical contact between the screen and the intake fitting. Remove any corrosion, debris or paint from the counter bore that will insulate the screen from the intake fitting. If the screen does not fit tightly, adjust the gap of the slot on the outside diameter of the screen to ensure a tight fit.

NOTE: Intake screen are die-cast which results in a slight taper from one side to the other. Install the screen with the thinner cross-section facing out to minimize flow restriction.

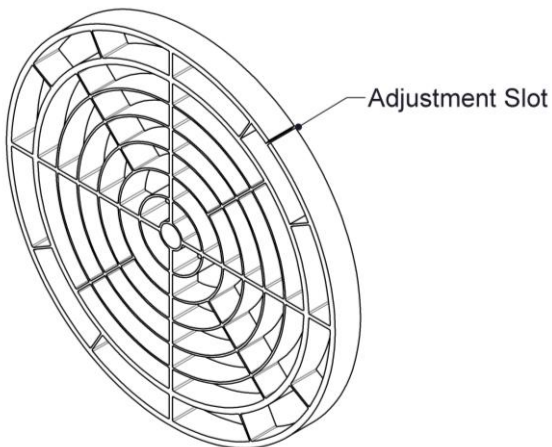

Intake Screen

IL4417-1

Anodes

Anodes may be mounted in the intake piping or, if no intake pads are available, in the discharge piping.

NOTE: The replaceable elements must make contact with water to be effective. Do not paint or use any other coating on the replaceable elements.

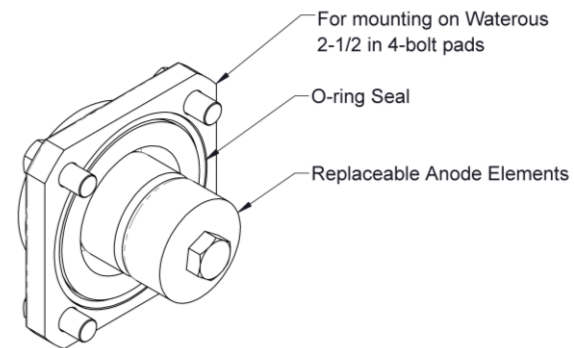

4-Bolt Anode

IL4417-2

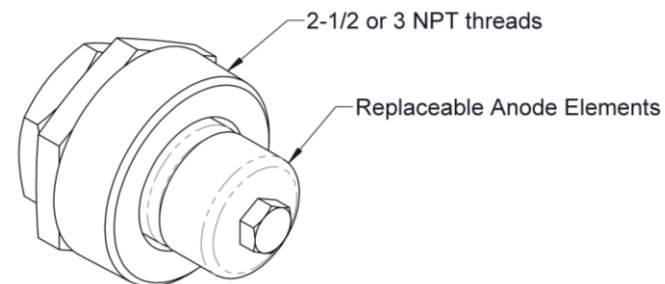

Threaded Anode

IL4417-3

Final Checks

Lubrication

Transmissions are shipped without lubricant and must be filled before the pump is operated.

NOTICE	
Failure to properly lubricate the pump transmission may result in serious damage to the equipment.	

The types of recommended lubricants are listed below:

Transmission Model	Capacity (Quarts or Liters) (See Note 1)	Lubricant (See Note 2)
Direct Drive (No Transmission, Fill Bearing Housing)	1/4	SAE 30 Non-Detergent Oil

Notes:

- 1) Capacities shown are approximate Quarts or Liters, always fill to the bottom of the plug labeled "Oil Level" or sight glass. Quantities listed vary based on ratio and/or mounting orientation.
- 2) Synthetic ATF and oil substitutes are acceptable.

Testing

Perform the tests listed in F-1031, Section 1000, "Centrifugal Fire Pump Principles of Operation, Inspection Tests and Troubleshooting Guide." During the running tests, monitor the smoothness of operation, listen for unusual noises and check for leaks.