

# WATEROUS

Form Number: F-2925

Issue Date: Jun 29, 2021  
Revision Date: Oct 2, 2024

## AQUIS™ ULTRAFLOW 300 Controls—Tellurus Control Panel Installation and Operation

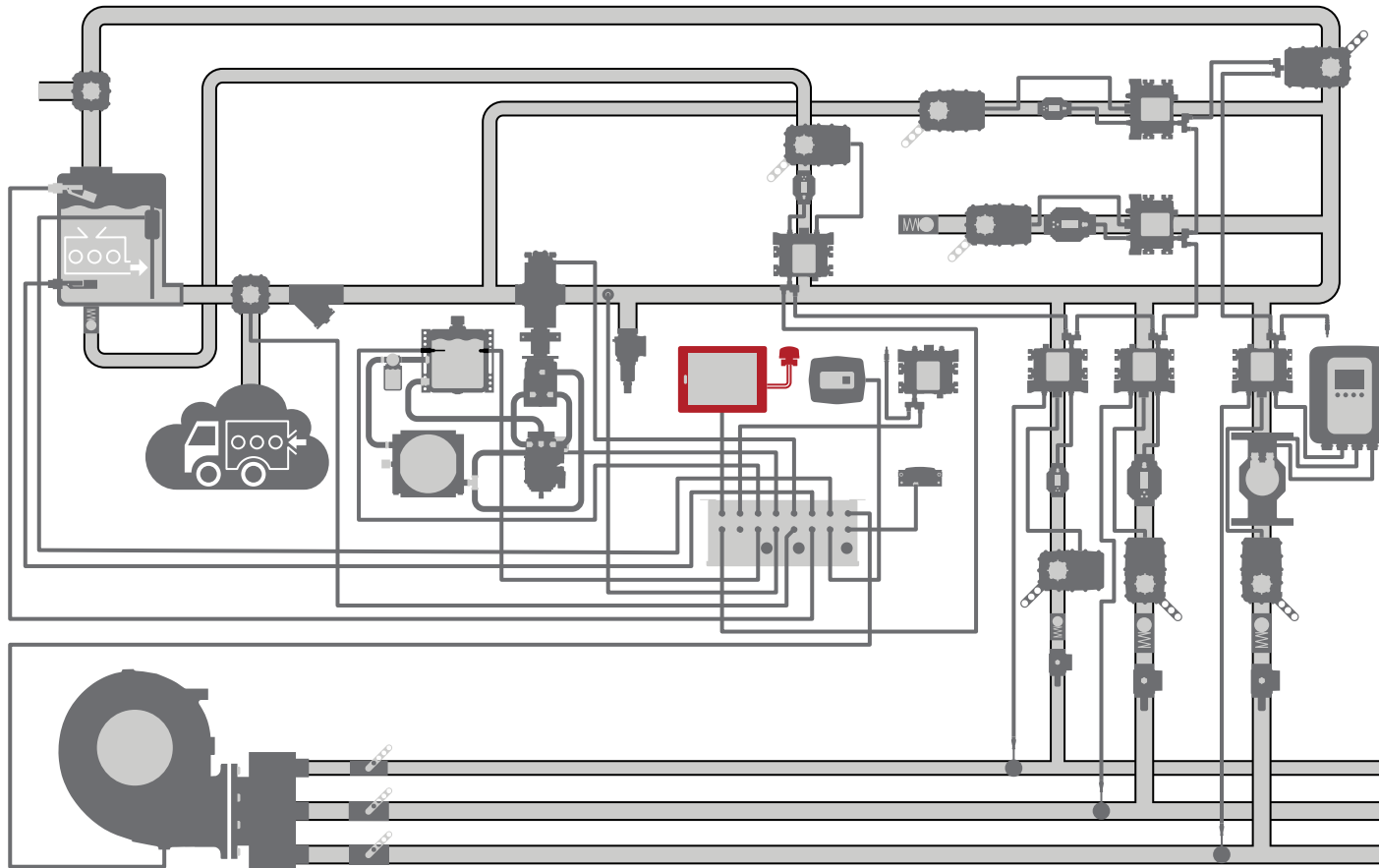

Waterous Company • 125 Hardman Avenue South • South Saint Paul, MN 55075 • (651) 450-5000

[www.waterousco.com](http://www.waterousco.com)



# Table of Contents

---

<b>Safety</b>	<b>4</b>
Safety Precautions	4
<b>Introduction</b>	<b>5</b>
Using this Document	5
Viewing the Document Electronically	5
Printing the Document	5
Additional Documentation	5
<b>Overview</b>	<b>6</b>
Aquis UltraFlow Industrial Foam Proportioner System	6
Control Panel and Components	10
15-Inch Tellurus Control Panel	12
8-Inch Tellurus Control Panel	14
WiFi and GPS Antenna	16
Tellurus HMI Cable	18
Tellurus CAN Cable	19
2.0 Meter CAN Cable	20
0.5 Meter CAN Cable	21
<b>Installation</b>	<b>22</b>
Installation Overview	22
Preparing for the Installation	22
Modifying the Equipment	22
Optional Equipment	22
Determining Panel and Plate Locations	23
Determining Cable and Wire Routing	23
Control Panel Cables and Connections	24
Connecting the Control Panel	26
<b>Operation</b>	<b>28</b>
Configuring and Operating the System	28
<b>Maintenance</b>	<b>29</b>
Maintenance Schedule	29

## Safety Precautions

- Read and understand all the associated documentation before you begin operating or overhauling the equipment.
- Contact Waterous when you have questions about operating, maintaining, or overhauling the equipment.
- Read and understand all the notices and safety precautions.
- Do not operate the equipment when safety guards are removed.
- Do not modify the equipment.

### NOTICE

#### Modification

- Modifying the equipment can damage components and void your warranty.
- Do not modify the system or any of its components.

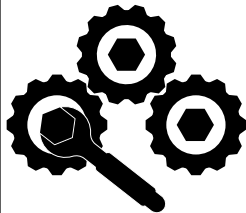

### NOTICE

#### Before Operation

- Read and understand all the instructions provided.
- Check all fluid levels and replenish if necessary.
- Remove all shipping plugs and install the operation plugs or caps.



### NOTICE

#### Concentrate Supply Contamination

- Priming with water can contaminate the on-board concentrate supply.
- Divert water to prevent concentrate contamination.



Use this document to install and operate your Waterous equipment. Understand the following conditions before continuing with the document:

- The instructions may refer to options or equipment that you may not have purchased with your system.
- The illustrations in this document are intended to convey concepts. Do not use the illustrations to determine physical attributes, placement, or proportion.
- Understand that your application may require additional steps, that are not described in the illustrations or instructions, to perform the installation.
- The equipment described in this document is intended to be installed by a person or persons with the necessary skills and knowledge to perform the installation.
- The equipment described in this document is intended to be operated by a person or persons with the basic knowledge of operating similar equipment.
- The information in this document is subject to change without notice.

This document is divided into the following sections:

#### SAFETY

This section describes general precautions and alert symbols in the document.

#### INTRODUCTION

This section is an overview of the document.

#### OVERVIEW

This section describes the components that make up the system.

#### INSTALLATION

This section describes the installation and initial setup procedures.

#### OPERATION

This section describes the equipment operation.

#### MAINTENANCE

This section describes any required maintenance.

## Using this Document

---

Use the guidelines below when viewing this document.

### Viewing the Document Electronically

---

- View this document in landscape orientation.
- Use the table of contents to navigate directly to that section.
- Text **with this appearance** is linked to a reference.

### Printing the Document

---

- The document is designed to be printed on both sides and in color.
- Use a 3-ring binder to store the document.

## Additional Documentation

---

Additional documentation is available through the MyWaterous login at [waterousco.com](http://waterousco.com). Use your serial number to gain access to the service parts list associated with your system. Dimensional drawings are available through the Waterous Service department.

## Aquis UltraFlow Industrial Foam Proportioner System

*Note: Make sure that the installer-supplied UltraFlow plumbing cannot trap fluid and allows fluid to be drained from the system when required.*

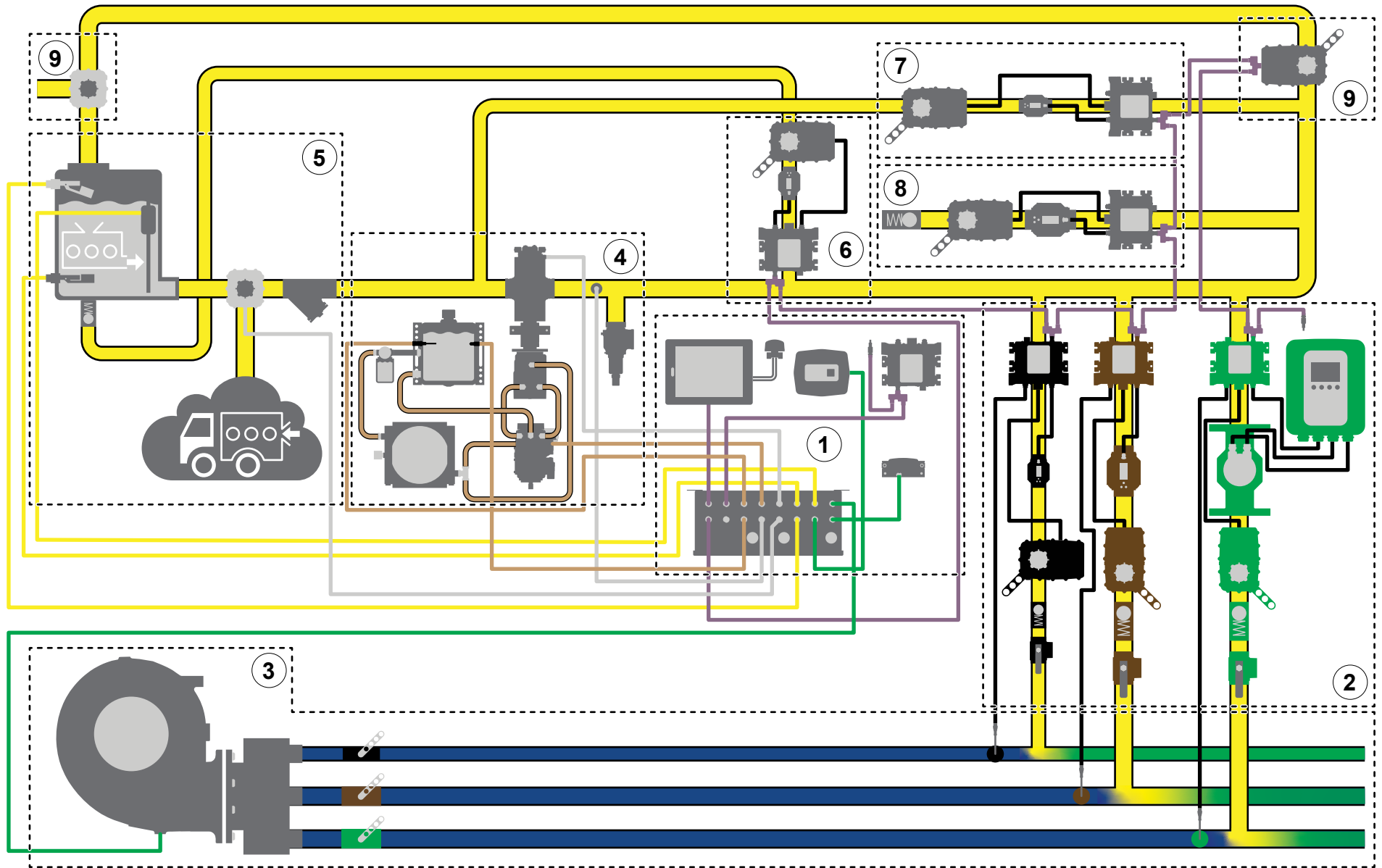

## Aquis UltraFlow Industrial Foam Proportioner System

The Aquis UltraFlow industrial foam proportioner system supplies concentrate into a solution-capable discharge line. A Tellurus™ control panel, or human machine interface (HMI), shows system activity and provides control of the system using a CANbus protocol. Foam concentrate is sourced from an on-board supply tank or an auxiliary source. The concentrate pump distributes concentrate through the discharge line assembly (DLA) using hydraulic components. The concentrate is then measured, controlled, and introduced into the solution-capable discharge line to produce foam solution. Understand that your application will include all or portions of the components described.

Subsystem	Description
1 Control system	<p>This monitors and controls the foam proportioner system. The components in this subsystem include:</p> <ul style="list-style-type: none"> <li>• Control panel—this displays system operation and provides control of the system.</li> <li>• Control box—this connects to various system components and contains the programmable logic controllers (PLCs).</li> <li>• Manual override panel—this disables the automatic control of the concentrate control valves.</li> <li>• Power relay panel—this enables and disables power to the DLA.</li> <li>• Remote I/O—this adds a node controller to the system for additional options required in your application.</li> <li>• Various cables—these provide communication and power to system components.</li> </ul>
2 Discharge line assembly	<p>This manages the concentrate injected into the solution-capable discharge. The system can control up to 19 DLAs. The components in this subsystem include:</p> <ul style="list-style-type: none"> <li>• Node controller—this connects to and controls the concentrate control valve, and reads the flowmeters and discharge pressure transducer.</li> <li>• CAN cable splitter—this connects the node controllers to one another and the control box.</li> <li>• DLA terminating resistor—this terminates the CAN connection on the last node controller or valve in the CAN chain.</li> <li>• Concentrate control valve—this controls the concentrate flow.</li> <li>• Magnetic flowmeter—this measures the concentrate flow.</li> <li>• Check valve—this prevents contamination of concentrate by preventing reverse fluid flow in the line.</li> <li>• Cal/Inject valve—this allows you to divert and collect water or concentrate when calibrating the your system.</li> </ul>
3 Solution-capable discharge	<p>This includes the installer-supplied water pump, distribution manifold, plumbing, and additional components that produce water flow. Additional components in this subsystem include:</p> <ul style="list-style-type: none"> <li>• Paddlewheel flowmeter—this measures the water flow in the discharge.</li> </ul> <p><b>Note:</b> You can install the flowmeter upstream or downstream of where the concentrate is injected into the waterway.</p> <ul style="list-style-type: none"> <li>• Water discharge pressure transducer—this measures the pressure at the pump discharge.</li> </ul> <p><b>Note:</b> Some applications do not allow for the discharge pressure to be measured at the pump, in those applications alternative measurement methods are used.</p> <ul style="list-style-type: none"> <li>• Solution discharge pressure transducer—this measures the pressure at the solution capable discharge.</li> </ul>

## Aquis UltraFlow Industrial Foam Proportioner System

Subsystem	Description
4 Concentrate pump	<p>These components support, control, and power the concentrate pump. The components in this subsystem include:</p> <ul style="list-style-type: none"> <li>• Concentrate pump—this circulates the foam concentrate through the system.</li> <li>• Hydraulic motor—this drives the concentrate pump.</li> <li>• Hydraulic pump—this drives the hydraulic motor.</li> <li>• Hydraulic reservoir—this contains the hydraulic fluid supply.</li> <li>• Hydraulic filter—this filters the hydraulic fluid.</li> <li>• Hydraulic heat exchanger—this cools the hydraulic fluid.</li> <li>• Hydraulic temperature sensor—this measures the hydraulic fluid temperature.</li> <li>• Hydraulic level sensor—this monitors the hydraulic fluid level in the reservoir.</li> <li>• Concentrate discharge pressure transducer—this measures the pressure in the concentrate line.</li> <li>• Pressure relief valve—this limits the pressure in the concentrate discharge manifold by opening when the pressure reaches a predetermined level.</li> </ul>
5 Concentrate supply	<p>This contains components that contain or supply foam concentrate for the system. The components in this subsystem include:</p> <ul style="list-style-type: none"> <li>• Concentrate supply tank—this contains the on-board foam concentrate supply.</li> <li>• Tank-full sensor—this indicates a tank full condition to the system.</li> <li>• Tank-low sensor—this indicates a tank low condition to the system.</li> <li>• Tank level sensor—this is an installer supplied sensor and display that indicates the supply level in the tank.</li> <li>• Concentrate pump intake select valve—this is an installer-supplied, 2-position valve and additional components that source concentrate from an on-board tank or an auxiliary supply. A signal is provided to the system to ignore the on-board tank sensors when sourcing concentrate from an auxiliary supply.</li> <li>• Concentrate strainer—this collects debris that would otherwise flow through the system and could damage the concentrate pump.</li> </ul>
6 Concentrate supply refill line	<p>This allows you to fill the on-board tank from an external source. The components in this subsystem include:</p> <ul style="list-style-type: none"> <li>• Node controller—this connects to the fill valve and flowmeters.</li> <li>• Fill line control valve—this controls the concentrate flow.</li> <li>• Magnetic flowmeter—this measures the concentrate flow.</li> <li>• CAN cable splitter—this connects the node controllers to one another and the control box.</li> <li>• Check valve—this prevents reverse fluid flow in the line.</li> </ul>



## Aquis UltraFlow Industrial Foam Proportioner System

Subsystem	Description
7 Low-flow bypass line	<p>This returns a portion of the concentrate in the supply line back to the pump inlet when the desired concentrate output requires the pump to operate at an rpm that is lower than its capabilities. The components in this subsystem include:</p> <ul style="list-style-type: none"> <li>• Node controller—this connects to the low-flow control valve and flowmeters.</li> <li>• Low-flow valve—this controls the concentrate return flow.</li> <li>• Magnetic flowmeter—this measures the concentrate flow.</li> <li>• CAN cable splitter—this connects the node controllers to one another.</li> </ul>
8 Transfer line	<p>This allows you to transfer or relay concentrate from the apparatus to another location. The components in this subsystem include:</p> <ul style="list-style-type: none"> <li>• Node controller—this connects to and controls the concentrate control valve and flowmeters.</li> <li>• CAN cable splitter—this connects the node controllers to one another and the control box.</li> <li>• Concentrate control valve—this controls the concentrate flow.</li> <li>• Magnetic flowmeter—this measures the concentrate flow.</li> <li>• Check valve—this prevents reverse fluid flow in the line.</li> </ul>
9 Priming line	<p>This evacuates air from the concentrate pump inlet as the system primes before operation. The components in this subsystem include:</p> <ul style="list-style-type: none"> <li>• Priming valve—this opens to allow air to evacuate the line before operation.</li> <li>• CAN cable splitter—this connects the node controllers to one another and the control box.</li> <li>• Prime bypass valve—this is an installer-supplied valve that prevents contaminating the concentrate during training. When water is substituted for concentrate during training or testing, and there is concentrate in the supply tank, this bypass valve prevents water from contaminating the concentrate supply.</li> </ul> <p><b>Note:</b> You must drain any remaining water in the line before priming the system with concentrate to prevent contamination.</p>

## Control Panel and Components

A comprehensive application of the UltraFlow system consists of multiple subsystems, including up to 19 DLAs to perform various functions, an on-board and auxiliary concentrate supply, equipment to circulate water and concentrate, and components to monitor and control the system.

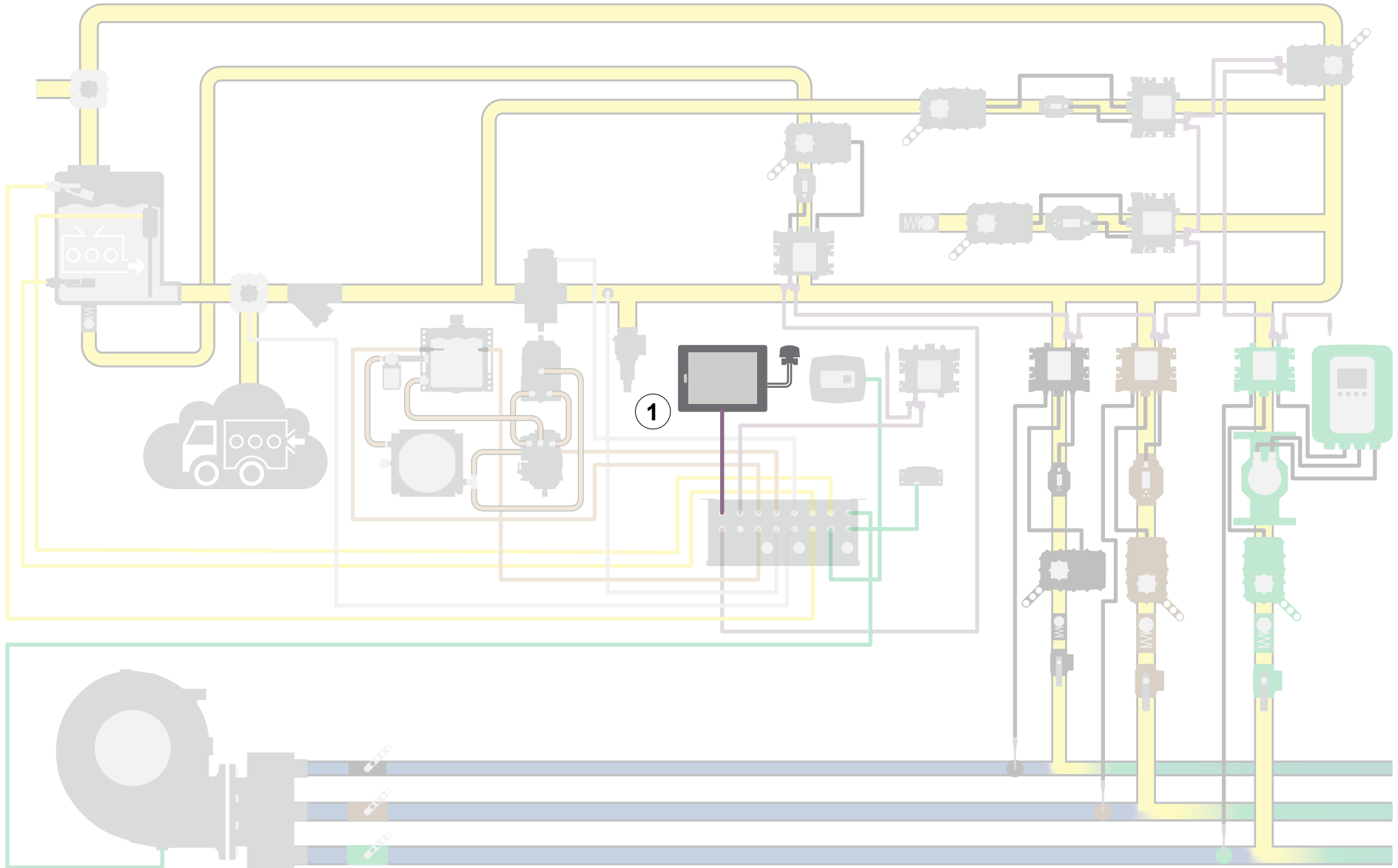

## Control Panel and Components

---

Subsystem	Description
1 Control panel	<p>The control panel allows the operator to interface with the control system and displays system information during operation.</p> <p>The components in this subsystem include:</p> <ul style="list-style-type: none"><li>• 8-inch or 15-inch control panel—this displays system operation and provides control of the system.</li><li>• WiFi and GPS antenna.</li><li>• Various cables—these provide communication and power to the control panel.</li></ul>

## 15-Inch Tellurus Control Panel

The control panel displays current operations and provides the operator control of the system.

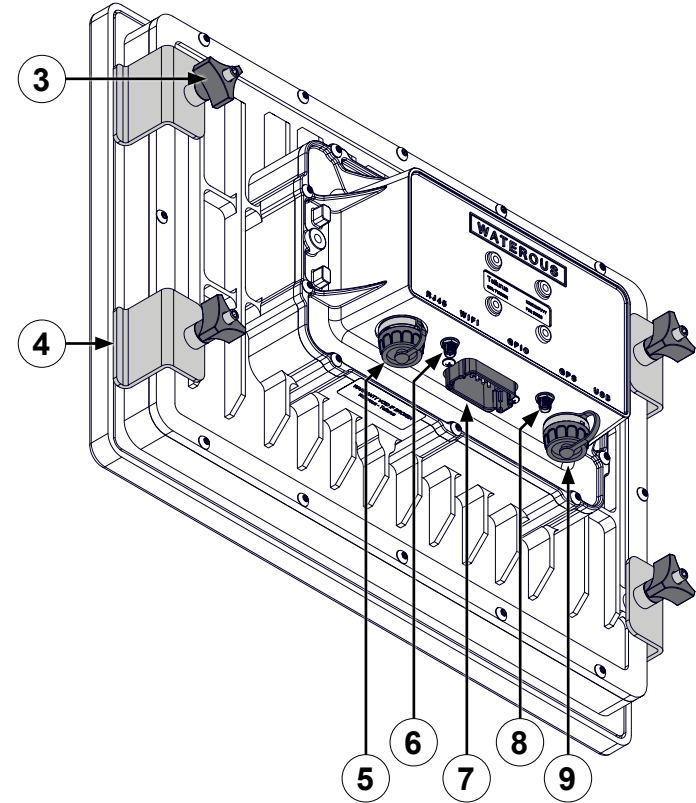
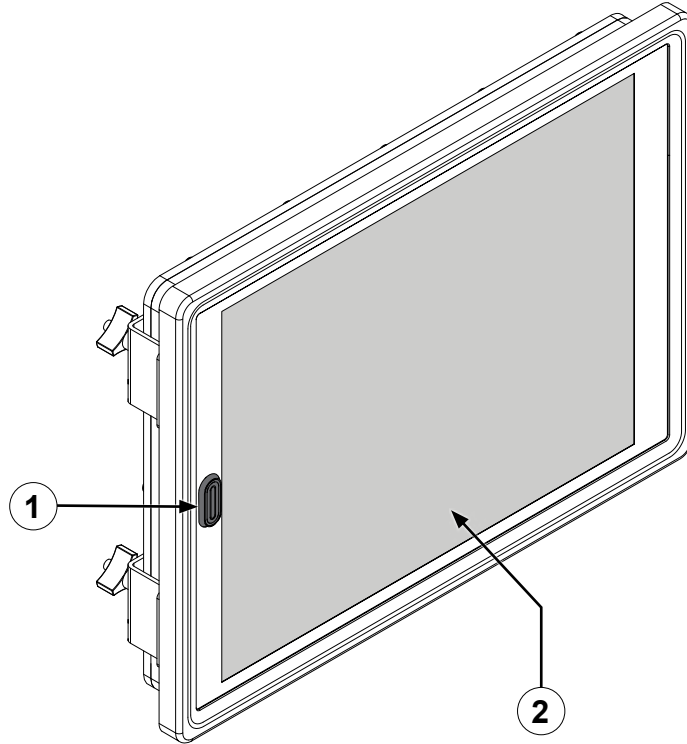

## 15-Inch Tellurus Control Panel

---

Feature	Description
1 Reset button	This indicates system status and allows the operator to reset the control panel.
2 Touchscreen	This displays operations and system controls.
3 Mounting knobs	These secure the control panel to the apparatus.
4 Mounting brackets	These secure the control panel to the apparatus.
5 RJ45 connector	This connects to a secondary control panel or truck Ethernet network.
6 WiFi connector	This connects to a WiFi antenna for wireless access.
7 GPIO connector	This connects external power and the control box.
8 GPS connector	This connects to the GPS antenna for location information.
9 USB connector	This connects a USB keyboard or flash drive for system configuration and updates.

## 8-Inch Tellurus Control Panel

The control panel displays current operations and provides the operator control of the system.

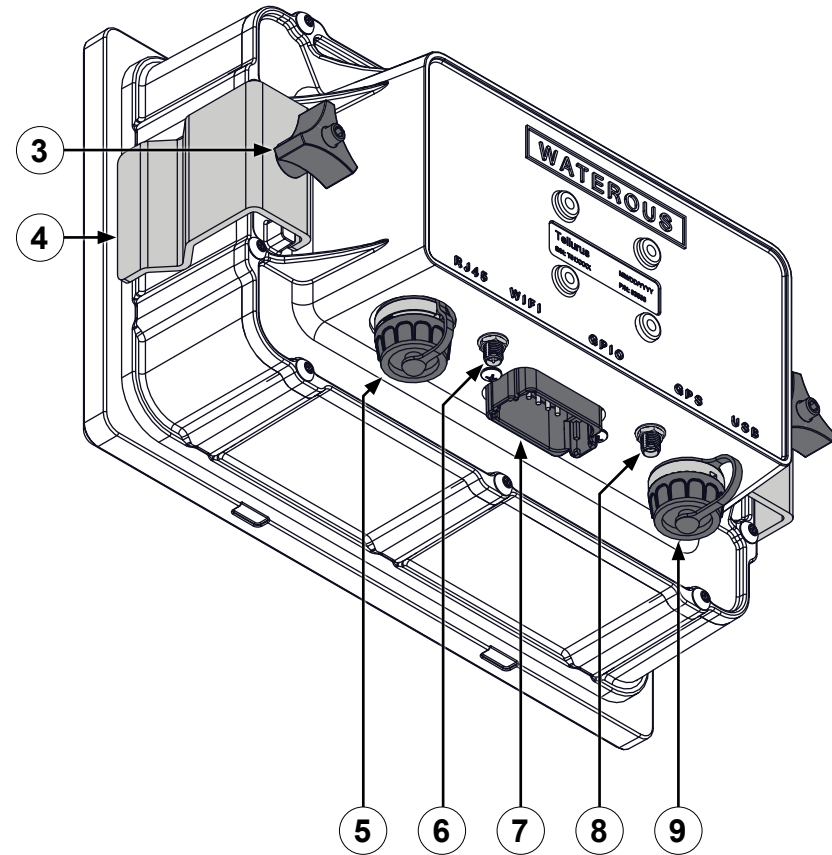
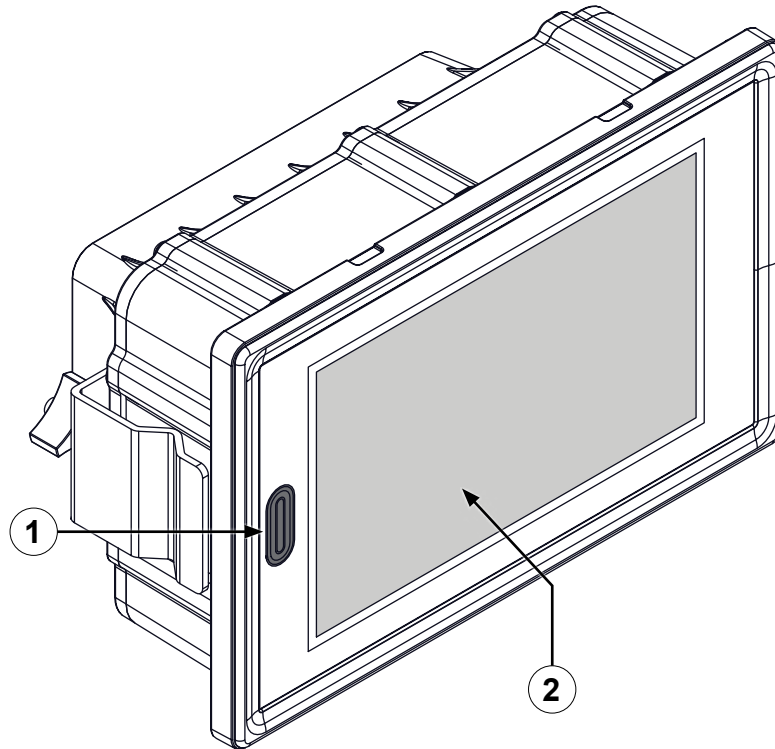

## 8-Inch Tellurus Control Panel

---

Feature	Description
1 Reset button	This indicates system status and allows the operator to reset the control panel.
2 Touchscreen	This displays operations and system controls.
3 Mounting knobs	These secure the control panel to the apparatus.
4 Mounting brackets	These secure the control panel to the apparatus.
5 RJ45 connector	This connects to a secondary control panel or truck Ethernet network.
6 WiFi connector	This connects to a WiFi antenna for wireless access.
7 GPIO connector	This connects external power and the control box.
8 GPS connector	This connects to the GPS antenna for location information.
9 USB connector	This connects a USB keyboard or flash drive for system configuration and updates.

## WiFi and GPS Antenna

The antenna receives WiFi and GPS signals.

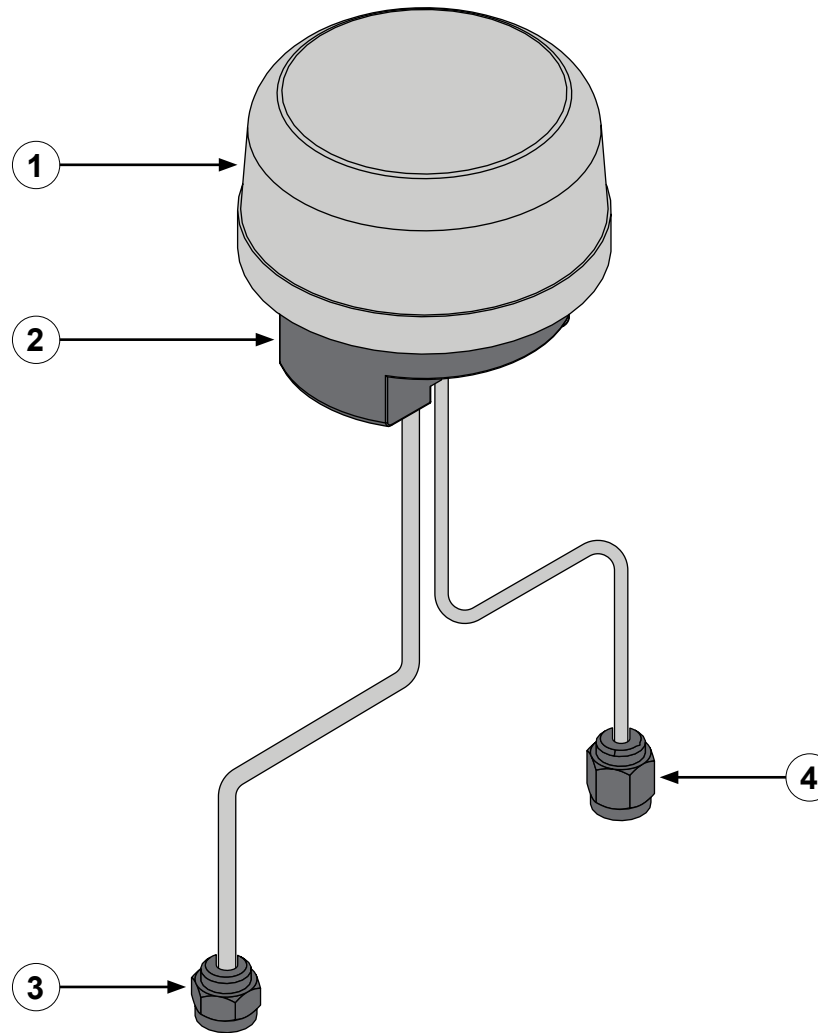



## WiFi and GPS Antenna

---

	Feature	Description
1	Antenna	This receives the WiFi and GPS signals.
2	Nut cover	This secures the antenna to the apparatus.
3	GPS connector	This connects the GPS connector to the control panel.
4	WiFi connector	This connects the WiFi connector to the control panel.

## Tellurus HMI Cable

This cable connects the control panel to the control box and system power. The power connector, associated connector components, and wiring are provided by the installer. Use the table to determine pin location.

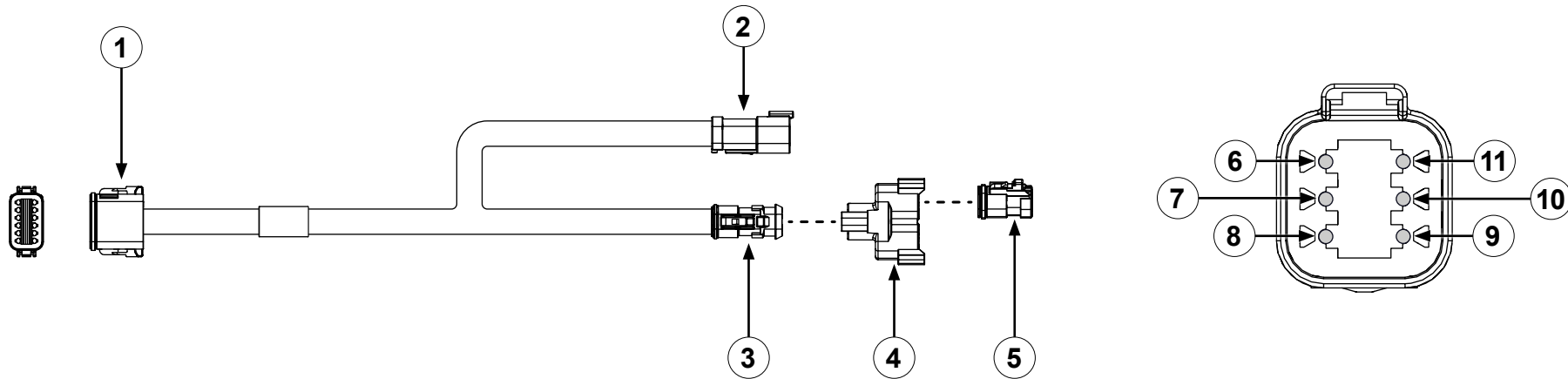

Feature	Description
1 Connector	This connects to the control panel—DT06-12SB.
2 Connector	This connects to apparatus power—DT04-6P-E003.
3 Connector	This connects to the Y-splitter receptacle.
4 Y-splitter receptacle	This connects to the Tellurus CAN cable.
5 Terminating resistor	This is installed into the Y-splitter receptacle.
6 Pin 6	CAN 2 high, yellow—optional CAN
7 Pin 5	Term 15, white +12V—back light power
8 Pin 4	+12V, red—power
9 Pin 3	CAN 2 low, green—optional CAN
10 Pin 2	Ground 2, black
11 Pin 1	Ground, black

**Note:** Pin 3 and pin 6 are only connected when the second CAN option is used.

## Tellurus CAN Cable

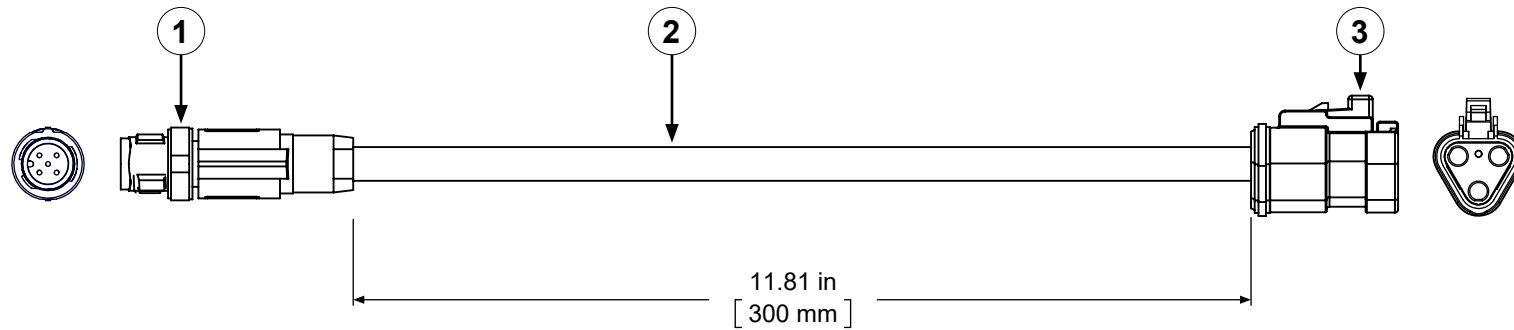

Feature	Description
1 M12 connector	This connects to the Tellurus HMI CANbus connector on the control box or a CAN cable connected to the control box.
2 Cable	This is a violet cable jacket.
3 Connector	This connects to the Y-splitter receptacle on the Tellurus HMI cable.

## 2.0 Meter CAN Cable

The CAN cable communicates data between the CAN connections. It is typically violet. The CAN cable is not interchangeable with the sensor cable. You can connect 2 or more cables together to achieve a desired length.

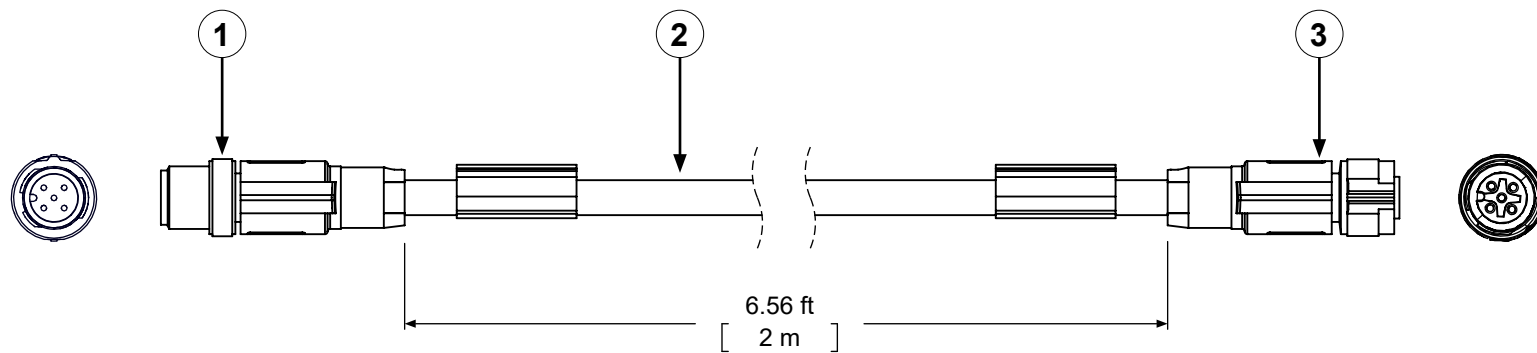

Feature	Description
1 M12 connector	This is a male connector.
2 Cable	This is typically a violet cable jacket.
3 M12 connector	This is a female connector.

## 0.5 Meter CAN Cable

The CAN cable communicates data between the CAN connections. It is typically violet. The CAN cable is not interchangeable with the sensor cable. You can connect 2 or more cables together to achieve a desired length.

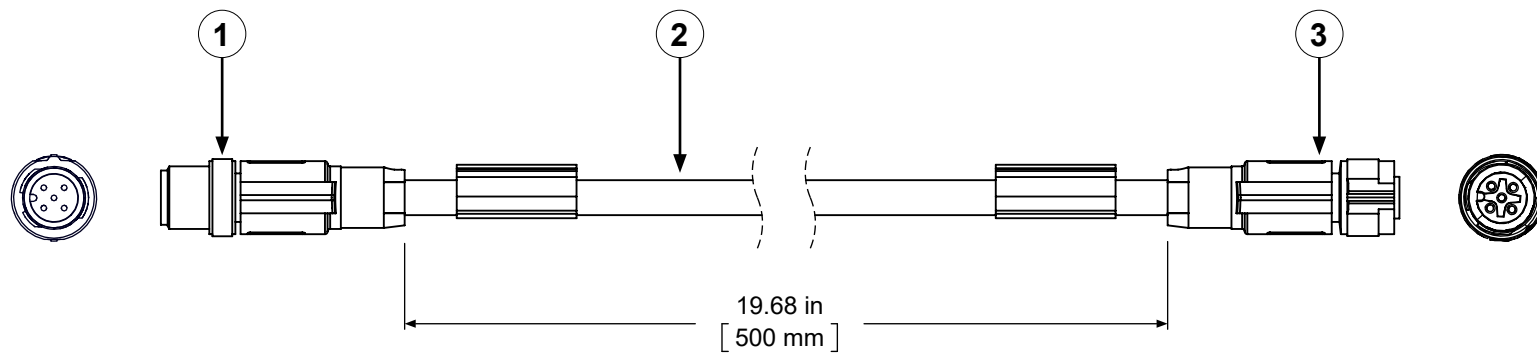

Feature	Description
1 M12 connector	This is a male connector.
2 Cable	This is typically a violet cable jacket.
3 M12 connector	This is a female connector.

## Installation Overview

This equipment is intended to be installed by a person or persons with the basic knowledge of installing similar equipment. Contact Waterous with questions about installing the equipment. The installation may require the following tasks and abilities:

- Locating, drilling, and cutting features into the apparatus.
- Welding.
- Installing the hoses and fittings.
- Routing and securing the hoses.
- Routing and securing the wiring.
- Calibrating the output.
- Calibration and final testing.

## Preparing for the Installation

Use the following guidelines before, during, and after the installation.

- Read and understand all the installation instructions before installing the equipment.
- Prepare a suitable, well-lit area, and gather all the necessary tools before you begin the installation.
- Make sure that you remove any shipping plugs or caps before installing the component.

Make sure that you bring all fluids to operating levels before using the equipment.

# NOTICE

## Before Operation

- Read and understand all the instructions provided.
- Check all fluid levels and replenish if necessary.
- Remove all shipping plugs and install the operation plugs or caps.



## Modifying the Equipment

This equipment is intended to operate as designed. Do not remove, modify, or change the components in the system. Doing so will void the warranty. Contact Waterous for more information.

# NOTICE

## Modification

- Modifying the equipment can damage components and void your warranty.
- Do not modify the system or any of its components.

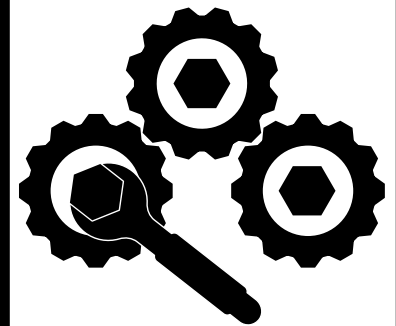

*Do not modify the system or any components. Doing so will void your warranty.*

## Optional Equipment

Be aware that the installation instruction may include optional equipment not included in your application.

## Determining Panel and Plate Locations

---

Use the following guidelines to determine a location to mount the control panel and instruction plate:

- Consider the cable and hose routing.
- Consider accessibility during operation and maintenance.
- Install instruction plates near their applicable operator panels.
- Refer to the dimensional drawings for cutout and mounting hole locations for your application.

## Determining Cable and Wire Routing

---

Use the *Wiring Best Practices* document, available at [www.waterousco.com](http://www.waterousco.com), as a guide to select and route wiring for your application.

## Control Panel Cables and Connections

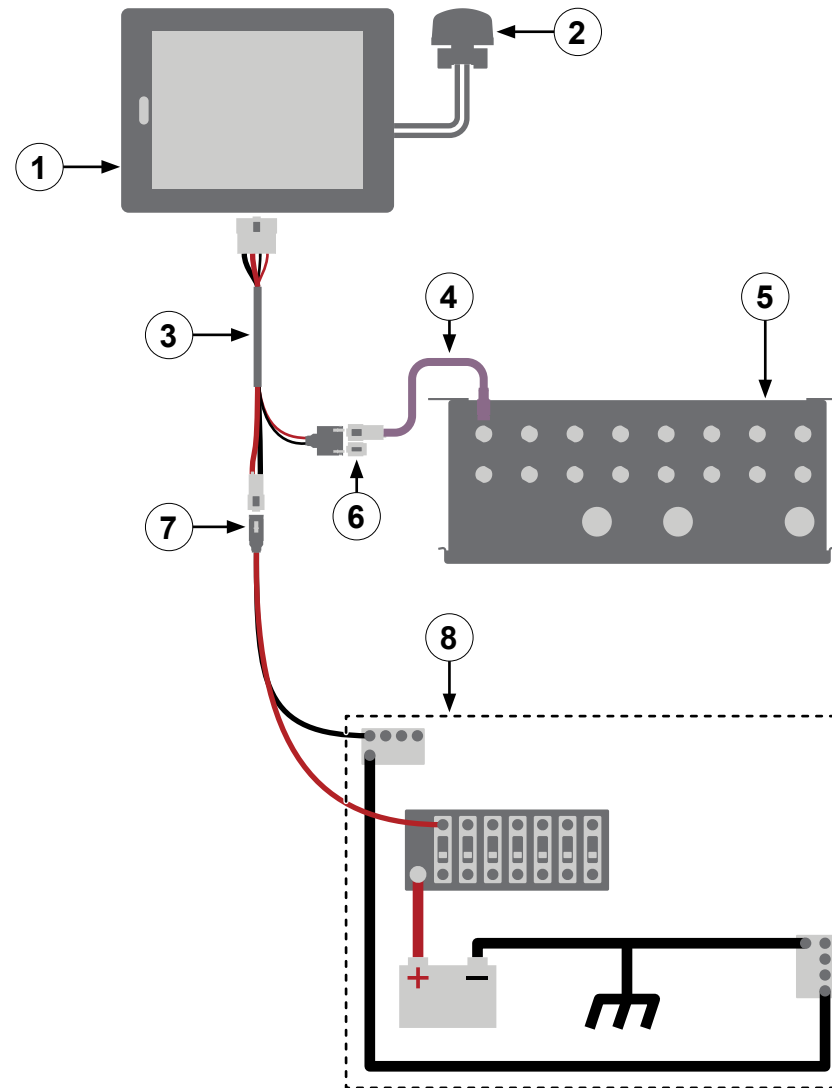



## Control Panel Cables and Connections

---

Feature	Description
1 Control panel	This displays system operation and provides the operator control of the system.
2 Antenna	This transmits and/or receives WiFi and GPS signals.
3 Tellurus HMI cable	This connects the control panel to power and to the Tellurus CAN cable.
4 Tellurus CAN cable	This connects the HMI cable to the control box.
5 Control box	This connects to various components in the system and contains the PLCs.
6 Terminating resistor	This terminates the CAN signal.
7 HMI power cable	This is the installer-supplied power cable. Refer to <b>"Tellurus HMI Cable" on page 18</b> for pin-out configuration.
8 System power	This is the system power.

## Connecting the Control Panel

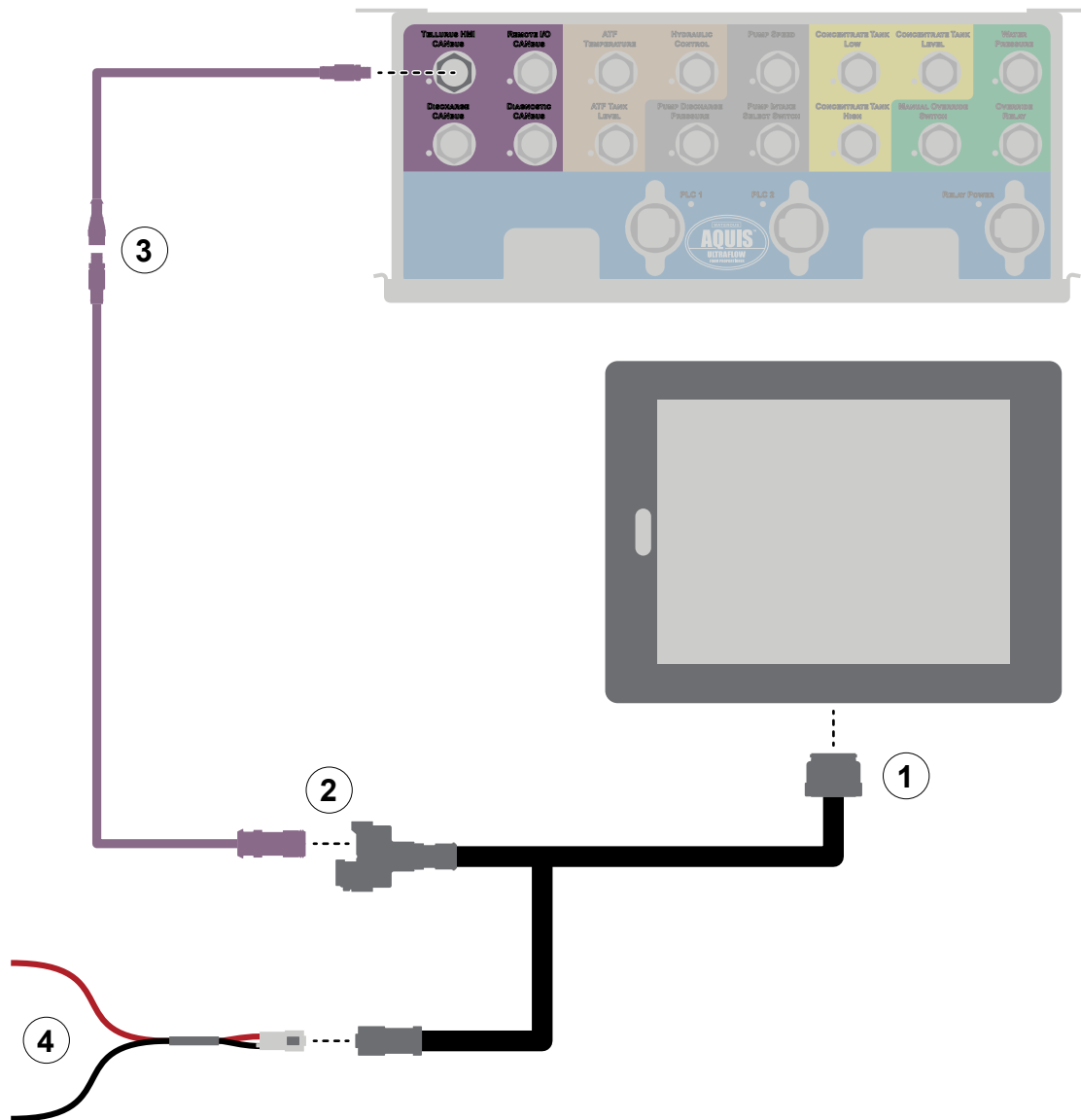

Use the illustration and instructions to connect the control panel to the control box.

- 1 Connect the Tellurus HMI cable to the control panel connector.
- 2 Connect the Tellurus HMI cable to the Tellurus CAN cable.
- 3 Connect the Tellurus CAN cable to the control box—Tellurus HMI CANbus connector.
- 4 Locally source a DT06-3S connector and appropriate cable to connect system power to the Tellurus HMI cable. Use a 10 A circuit breaker to power the node controller. Refer to **"Tellurus HMI Cable"** on page 18.

## Connecting the Keyboard and USB Drive

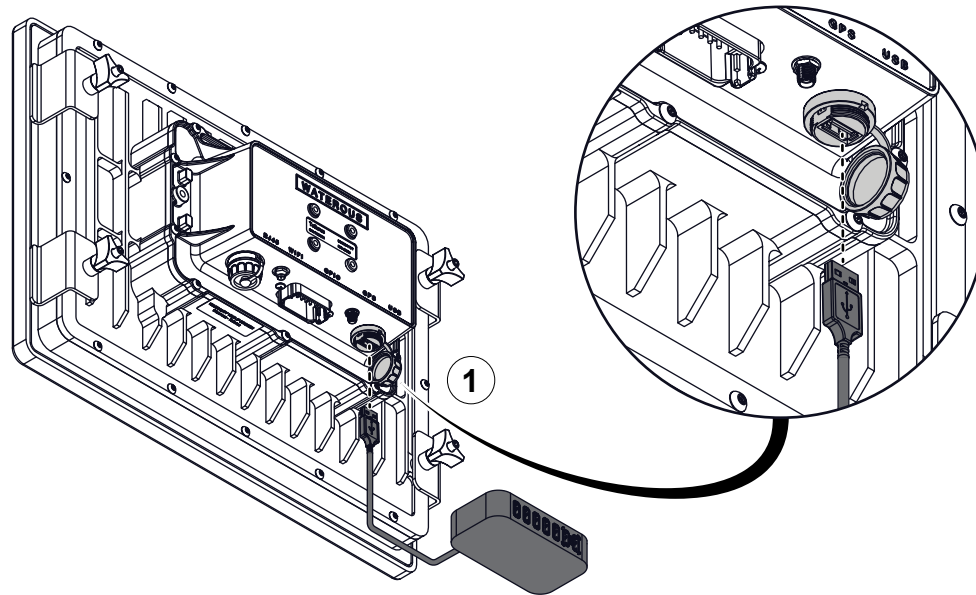

Use the illustrations and instructions to connect an external keyboard and USB drive to the control panel. The USB drive can be used to download and save the current configuration file, upload a new configuration, or restore a previous configuration.

To transfer configuration files, you will need the following:

- A USB hub to connect the control panel to the keyboard and USB drive.
- A USB keyboard to navigate through the menu.
- A USB drive to store and retrieve configuration files.

**Note:** Only use components with a USB standard of 2.0 or higher.

- 1 Plug the USB hub into the USB port on the control panel.
- 2 Plug the USB drive into the USB hub if you are transferring files.
- 3 Plug the USB keyboard and mouse into the USB hub.

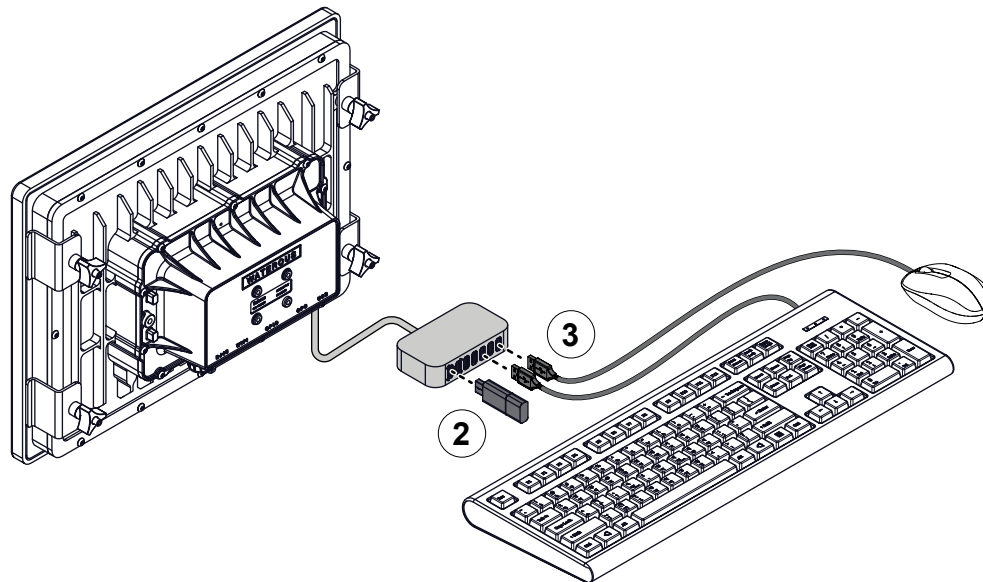

## Configuring and Operating the System

The UltraFlow system is composed of elements that are configured to your specific application, including DLAs, flowmeters, valves, switches, sensors, and more. The system is configured using the UltraFlow configuration wizard, a software assistant that guides you through the configuration steps on the control panel touchscreen. Following the initial configuration, you can operate the system from the control panel, which provides the ability to enable and disable the DLAs, adjust the concentrate percentages for each discharge, change the concentrate source, and prime the system.

The UltraFlow software documentation can be found online. It is continually updated with the current software version. To access the documentation, scan or click on the QR code.

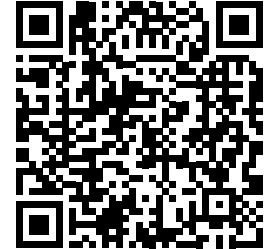

## Maintenance Schedule

---

No scheduled maintenance is required for the control system. However, it is recommended that you periodically inspect the system to reveal excess debris buildup, worn components, or any developing leaks. Consider environmental conditions, hours of operation, and other factors specific to your application to develop a suitable inspection schedule.

**WATEROUS**

Waterous Company  
125 Hardman Avenue South  
South Saint Paul, MN 55075  
(651) 450-5000  
[www.waterousco.com](http://www.waterousco.com)