

# WATEROUS

Form Number: F-2930

Issue Date: Sept 17, 2021  
Revision Date: Jan 13, 2023

## Overheat Protection Manager

### Installation, Operation, and Maintenance

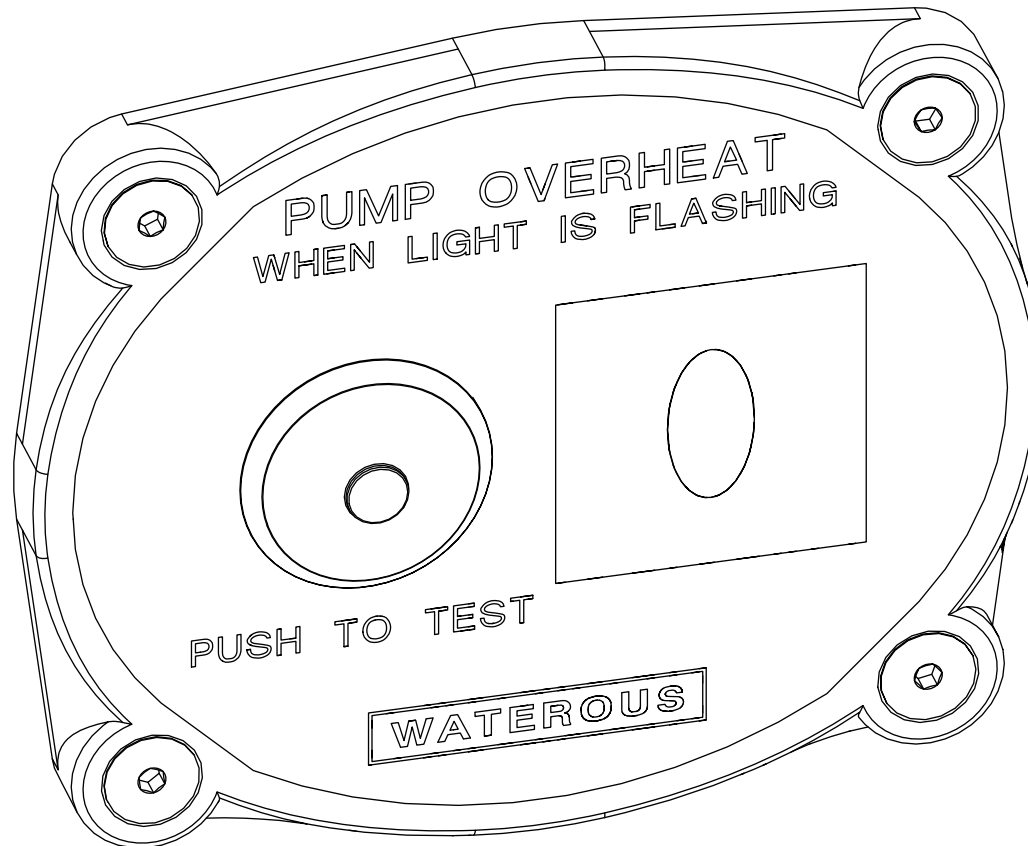

Waterous Company • 125 Hardman Avenue South • South Saint Paul, MN 55075 • (651) 450-5000

[www.waterousco.com](http://www.waterousco.com)



# Table of Contents

---

<b>Safety</b>	<b>4</b>	<b>Operation</b>	<b>28</b>
Safety Precautions	4	Operation	28
<b>Introduction</b>	<b>5</b>	<b>Maintenance</b>	<b>29</b>
Using this Document	5	Maintenance Schedule	29
Viewing the Document Electronically	5	<b>Troubleshooting</b>	<b>30</b>
Printing the Document	5	Troubleshooting Guide	30
Symbols	5		
<b>Product Overview</b>	<b>6</b>		
Overheat Protection Manager (OPM) Overview	6		
OPM Control Panel	8		
Audible Alarm	10		
Thermal Valve	12		
Thermal Switch	13		
Extension Cable	14		
<b>Installation</b>	<b>16</b>		
Installation Overview	16		
Preparing for the Installation	16		
Modifying the Equipment	16		
Optional Equipment	16		
Determining Cable and Wire Routing	16		
OPM Control Panel Cutout and Mounting Holes	17		
Audible Alarm Cutout	18		
Installing the OPM—CM & CS Series Pumps	19		
Locating the Thermal Valve and Switch	19		
Installing the OPM—Other Pump Models	20		
Mounting the Flange	20		
Installing the Thermal Valve and Switch	21		
Installing the Thermal Valve and Switch Without a Discharge Fitting	22		
Installing the OPM—All Pump Models	23		
Mounting the OPM Control Panel	23		
Connecting the Cables and Wires	24		
Installing the Audible Alarm	25		
Connecting the Alarm to the OPM	25		
Mounting the Alarm	26		
Connecting the Alarm to Power	27		

## Safety Precautions

- Read and understand all the associated documentation before you begin the installation.
- Read and understand all the notices and safety precautions.
- Be aware that these instructions are only guidelines and are not meant to be definitive. Contact Waterous when you have questions about installing, operating, or maintaining the equipment.
- Do not install the equipment if you are not familiar with the tools and skills needed to safely perform the required procedures—proper installation is the responsibility of the purchaser.
- Do not operate the equipment when safety guards are removed.
- Do not modify the equipment.
- Regularly check for leaks and worn or deteriorated parts.

## NOTICE

### Modification

- **Modifying the equipment can damage components and void your warranty.**
- **Do not modify the system or any of its components.**

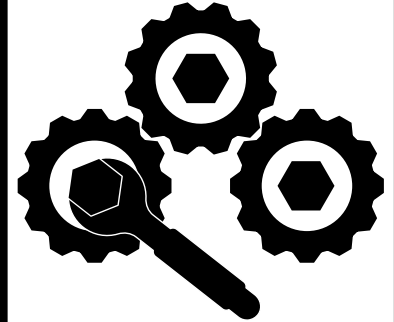

## NOTICE

### Before Operation

- **Read and understand all the instructions provided.**
- **Check all fluid levels and replenish if necessary.**
- **Remove all shipping plugs and install the operation plugs or caps.**



Use this document to install and operate your Waterous equipment. Understand the following conditions before continuing with the document:

- The instructions may refer to options or equipment that you may not have purchased with your system.
- The illustrations in this document are intended to convey concepts. Do not use the illustrations to determine physical attributes, placement, or proportion.
- Understand that your application may require additional steps, that are not described in the illustrations or instructions, to perform the installation.
- The equipment described in this document is intended to be installed by a person or persons with the necessary skills and knowledge to perform the installation.
- The equipment described in this document is intended to be operated by a person or persons with the basic knowledge of operating similar equipment.
- The information in this document is subject to change without notice.

This document is divided into the following sections:

#### SAFETY

This section describes general precautions and alert symbols that are in the document.

#### INTRODUCTION

This section is an overview of the document.

#### PRODUCT OVERVIEW

This section describes the various components that make up the system.

#### INSTALLATION

This section describes the installation and initial setup procedures.

#### OPERATION

This section describes equipment operation.

#### MAINTENANCE

This section describes required maintenance.

#### TROUBLESHOOTING

This section describes how to troubleshoot any issues with the equipment.

## Using this Document

Use the guidelines below when viewing this document.

### Viewing the Document Electronically

- View this document in landscape orientation.
- Use the table of contents to navigate directly to that section.
- Text **with this appearance** is linked to a reference.

### Printing the Document

- The document is viewed the best when printed in color.
- The *print on both sides* and *flip on long edge* features can provide the best results.
- Use a 3-ring binder to store the document.

## Additional Documentation

Additional documentation is available through the MyWaterous login at [waterousco.com](http://waterousco.com). Use your serial number to gain access to the service parts list associated with your system. Dimensional drawings are available through the Waterous Service department.

## Symbols

Symbols are used to illustrate additional tools or operations that are required to complete the instructions.



Drill—This symbol tells you to drill holes in the apparatus.



Jig saw—This symbol tells you to make a cutout in the apparatus.

## Overheat Protection Manager (OPM) Overview

The OPM is a safety device that releases hot water to the ground or back to the water tank when the pump is overheating. Use the illustrations and tables to identify various components of the OPM.

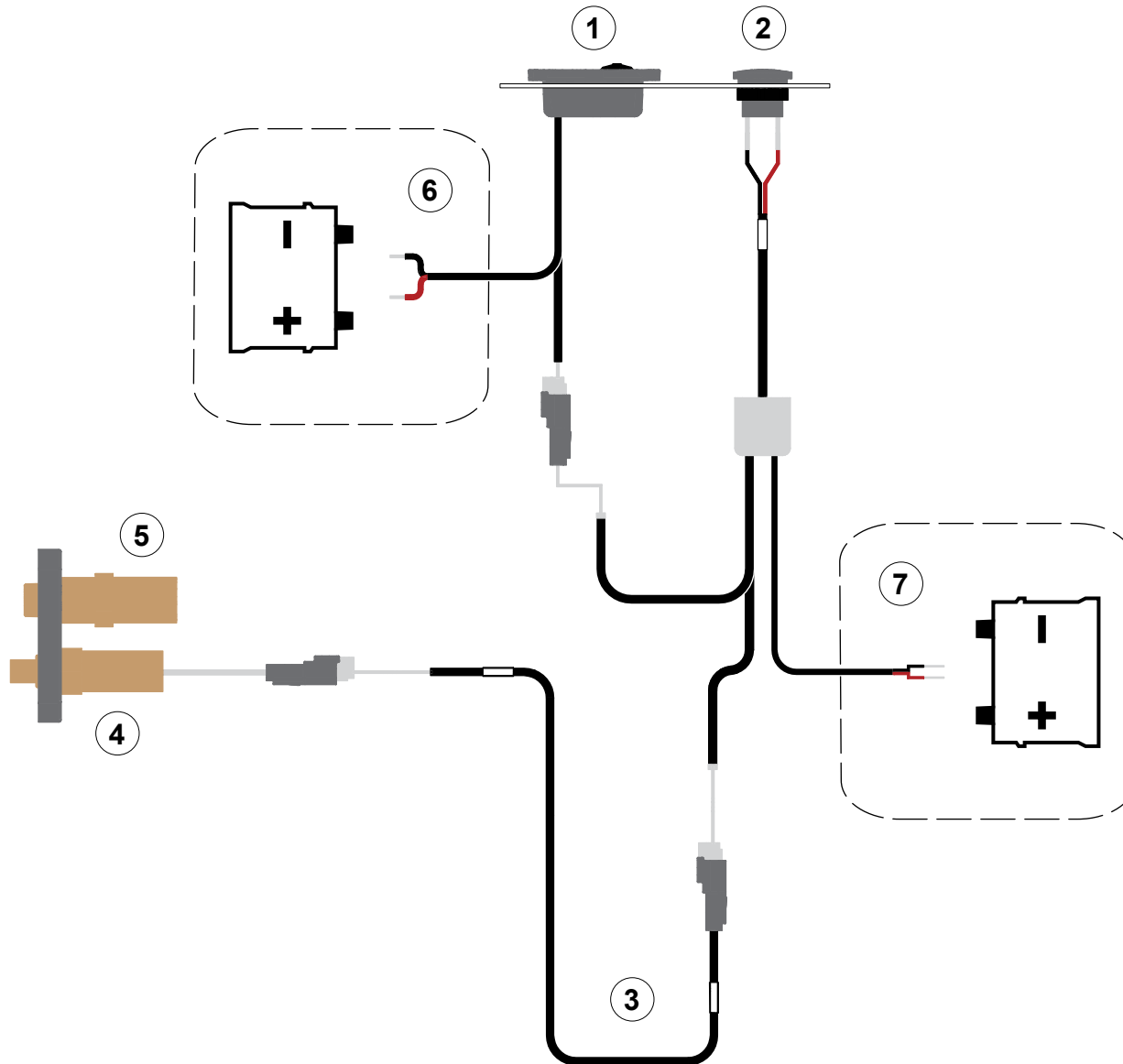

## Overheat Protection Manager (OPM) Overview

Feature	Description
1 OPM control panel	This connects to the audible alarm and a power source. The <i>TEST</i> button checks the circuit and the control panel LED emits light when the pump is overheating or the <i>TEST</i> button is pressed.
2 Audible alarm (optional)	This connects to the OPM control panel assembly, extension cord, and a power source. It emits sound when the pump is overheating or the <i>TEST</i> button is pressed. <b>Note:</b> Alarms purchased prior to September 2021 do not produce sound when the <i>TEST</i> button is pressed.
3 Extension cord	This connects to the audible alarm and thermal switch. Without the audible alarm, the extension cord connects to the control panel and thermal switch.
4 Thermal switch	This is installed directly into the pump (CM & CS Series) or into the flange (all other models) and connects to the extension cord. It signals to the OPM when the pump is overheating.
5 Thermal valve	This is installed directly into the pump (CM & CS Series) or into the flange (all other models). It releases hot water to the ground or back to the water tank when the pump is overheating.
6 Power—locally sourced	This provides power to the OPM.
7 Power—locally sourced	This provides power to the audible alarm.

## OPM Control Panel

The OPM control panel is mounted on the operator panel and contains the *TEST* button and LED light.

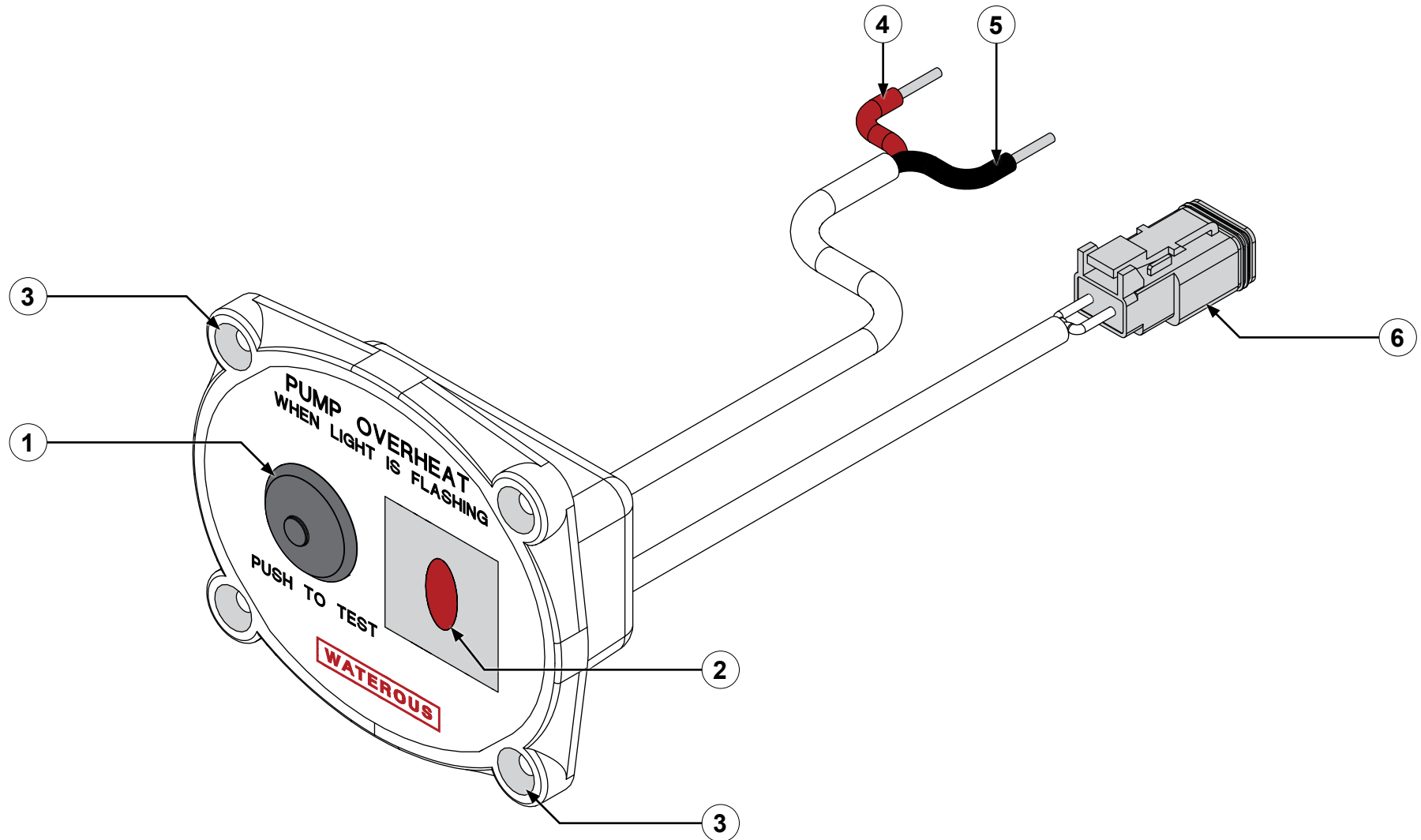



## OPM Control Panel

Feature	Description
1 <i>TEST</i> button	Press this to test the circuit after installation.
2 Control panel LED	This emits light when the pump is overheating or the <i>TEST</i> button is pressed.
3 Mounting holes	These are used to mount the OPM control panel on the apparatus.
4 Bare lead—red	This connects to 12–24VDC.
5 Bare lead—black	This connects to ground.
6 Deutsch plug	This connects to the extension cable or audible alarm.

## Audible Alarm

The audible alarm emits sound when the pump is overheating or the *TEST* button is pressed.

**Note:** Alarms purchased prior to September 2021 do not produce sound when the *TEST* button is pressed.

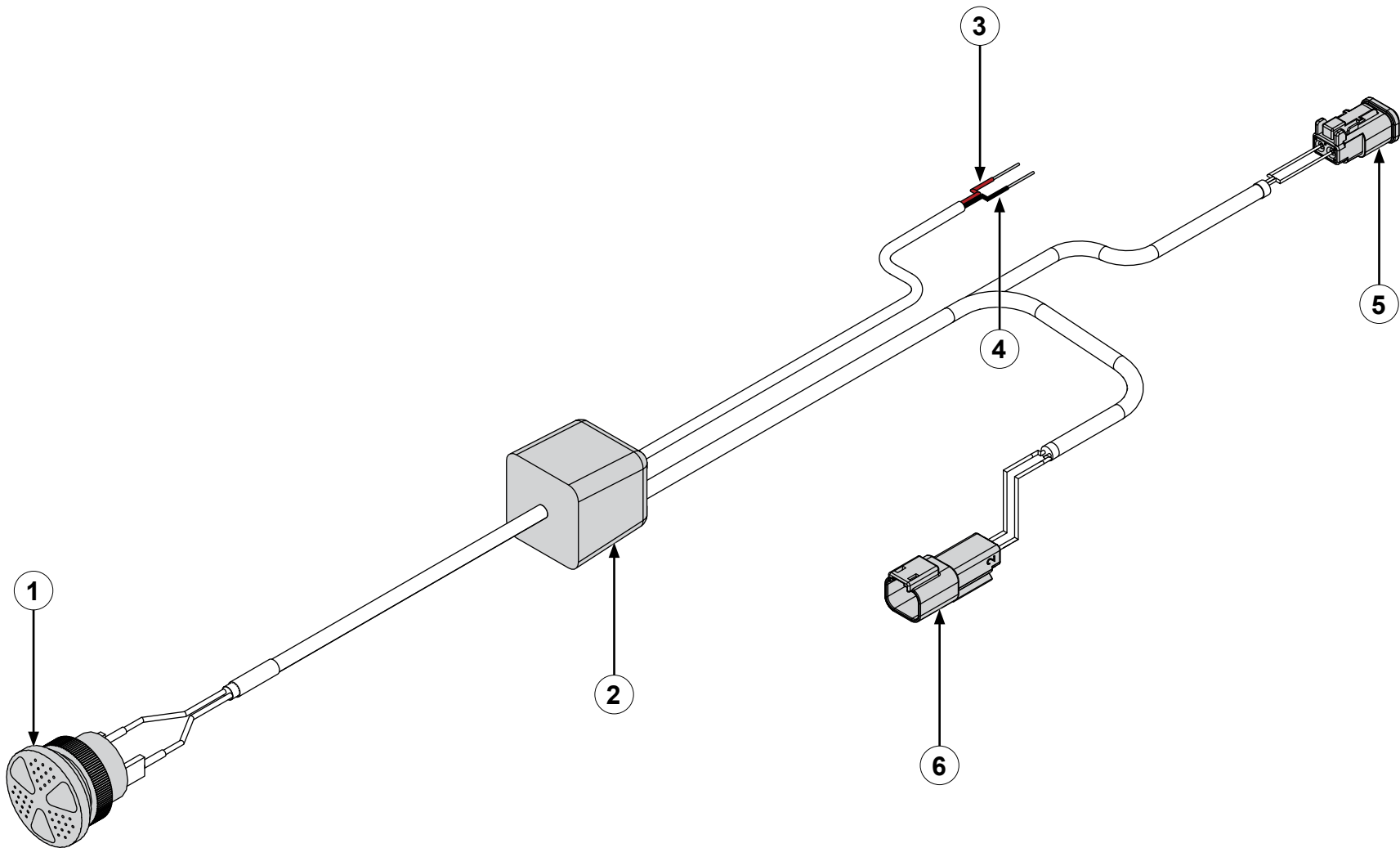

## Audible Alarm

Feature	Description
1 Alarm	This is mounted on the operator panel.
2 Potted module	This houses the alarm wiring.
3 Bare lead—red	This connects to 12–24VDC.
4 Bare lead—black	This connects to ground.
5 Deutsch plug	This connects to the thermal switch.
6 Deutsch receptacle	This connects to the control panel.

## Thermal Valve

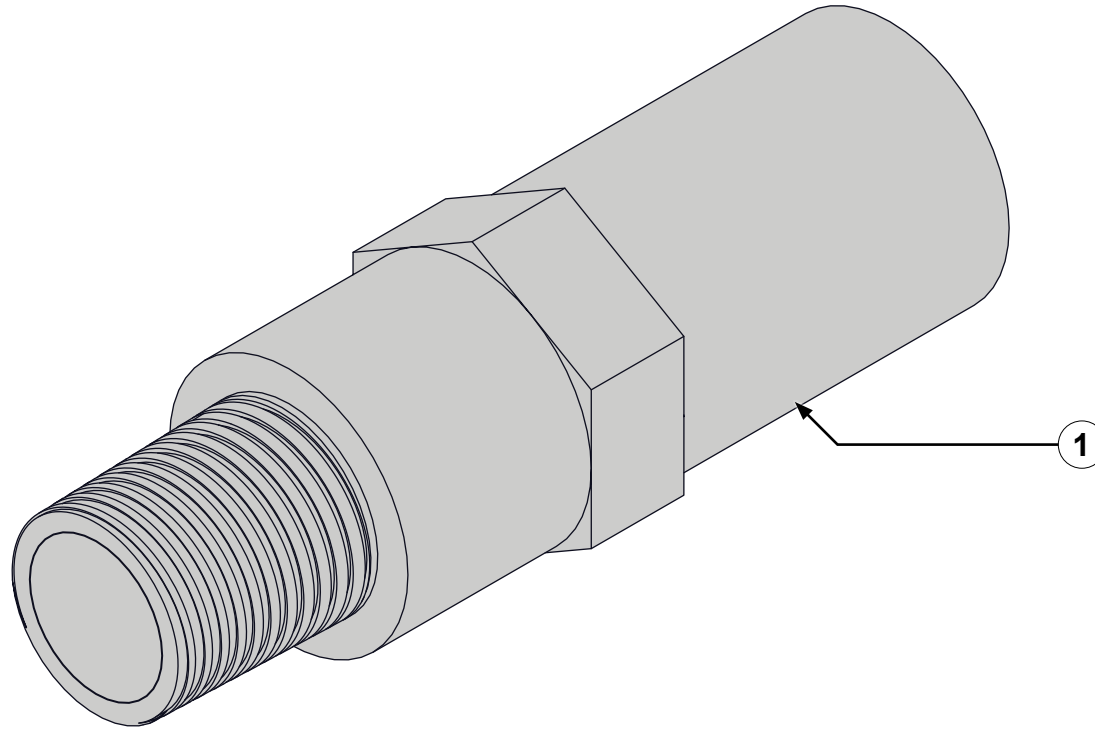

Feature	Description
1 Thermal valve—1/2 NPT	This is installed directly into the pump (CM & CS Series, HL Series) or into the flange (all other models).

## Thermal Switch

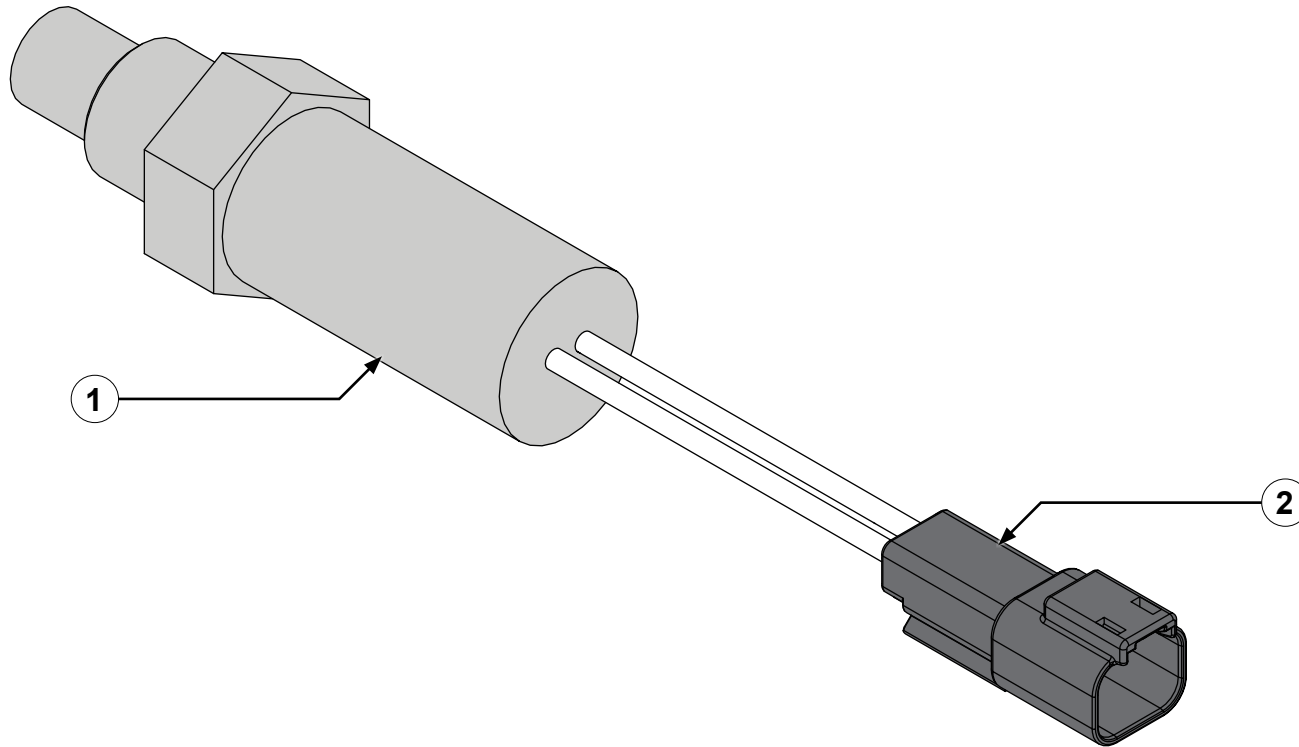

Feature	Description
1 Thermal switch—1/2 NPT	This is installed directly into the pump (CM & CS Series) or into the flange (all other models).
2 Deutsch receptacle	This connects to the extension cable Deutsch plug.

## Extension Cable



Feature	Description
1 Deutsch plug	This connects to the thermal switch.
2 Deutsch receptacle	This connects to the OPM control panel or audible alarm Deutsch plug.

## Notes

## Installation Overview

This equipment is intended to be installed by a person or persons with the basic knowledge of installing similar equipment. Contact Waterous with questions about installing the equipment. The installation may require the following tasks and abilities:

- Locating, drilling, and cutting features into the apparatus.
- Routing and securing the wiring.
- Calibration and final testing.

## Preparing for the Installation

Use the following guidelines before, during, and after the installation.

- Read and understand all the installation instructions before installing the equipment.
- Prepare a suitable, well-lit area and gather all the necessary tools before you begin the installation.
- Make sure that you remove any shipping plugs or caps before installing the component.
- Make sure that you bring all fluids to operating levels before using the equipment.

## NOTICE

### Before Operation

- Read and understand all the instructions provided.
- Check all fluid levels and replenish if necessary.
- Remove all shipping plugs and install the operation plugs or caps.



## Modifying the Equipment

This equipment is intended to operate as designed. Do not remove, modify, or change the components in the system. Doing so will void the warranty. Contact Waterous for more information.

## NOTICE

### Modification

- Modifying the equipment can damage components and void your warranty.
- Do not modify the system or any of its components.

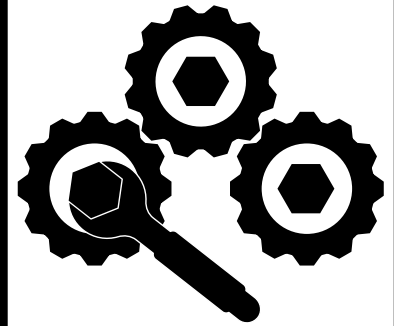

*Do not modify the system or any of its components. Doing so will void your warranty.*

## Optional Equipment

Be aware that the installation instructions may include optional equipment not included in your application.

## Determining Cable and Wire Routing

Use the *Wiring Best Practices* document, available at [www.waterousco.com](http://www.waterousco.com), as a guide to select and route wiring for your application.



## OPM Control Panel Cutout and Mounting Holes

Use the illustration to create the cutout and drill the mounting holes for the OPM control panel.

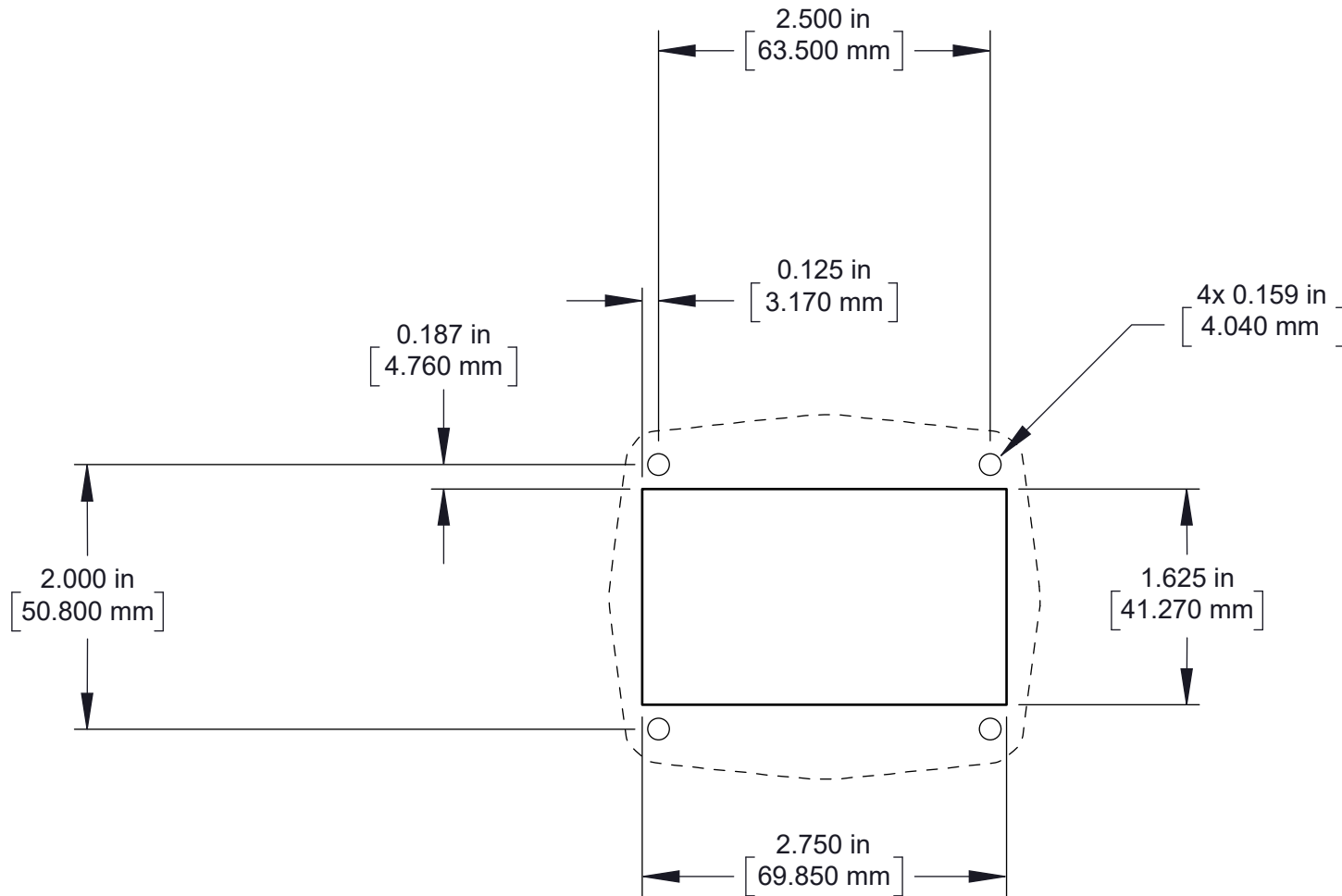

## Audible Alarm Cutout

Use the illustration to create the cutout for the optional audible alarm.

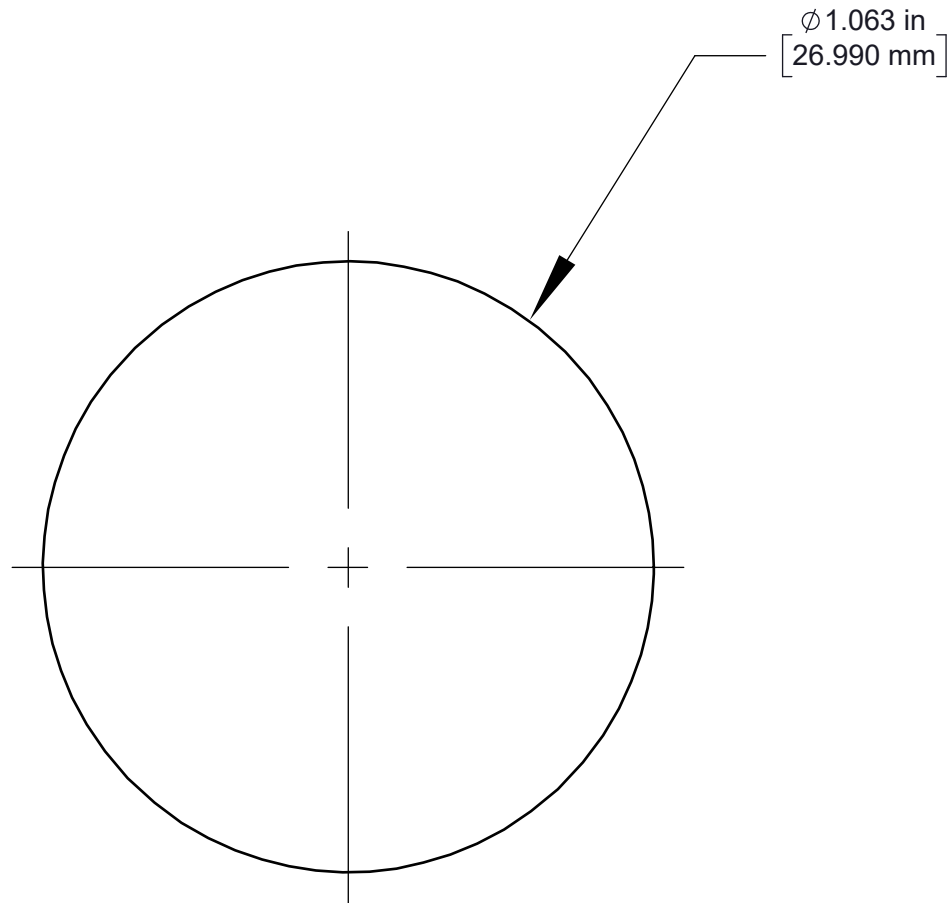

## Installing the OPM—CM & CS Series Pumps

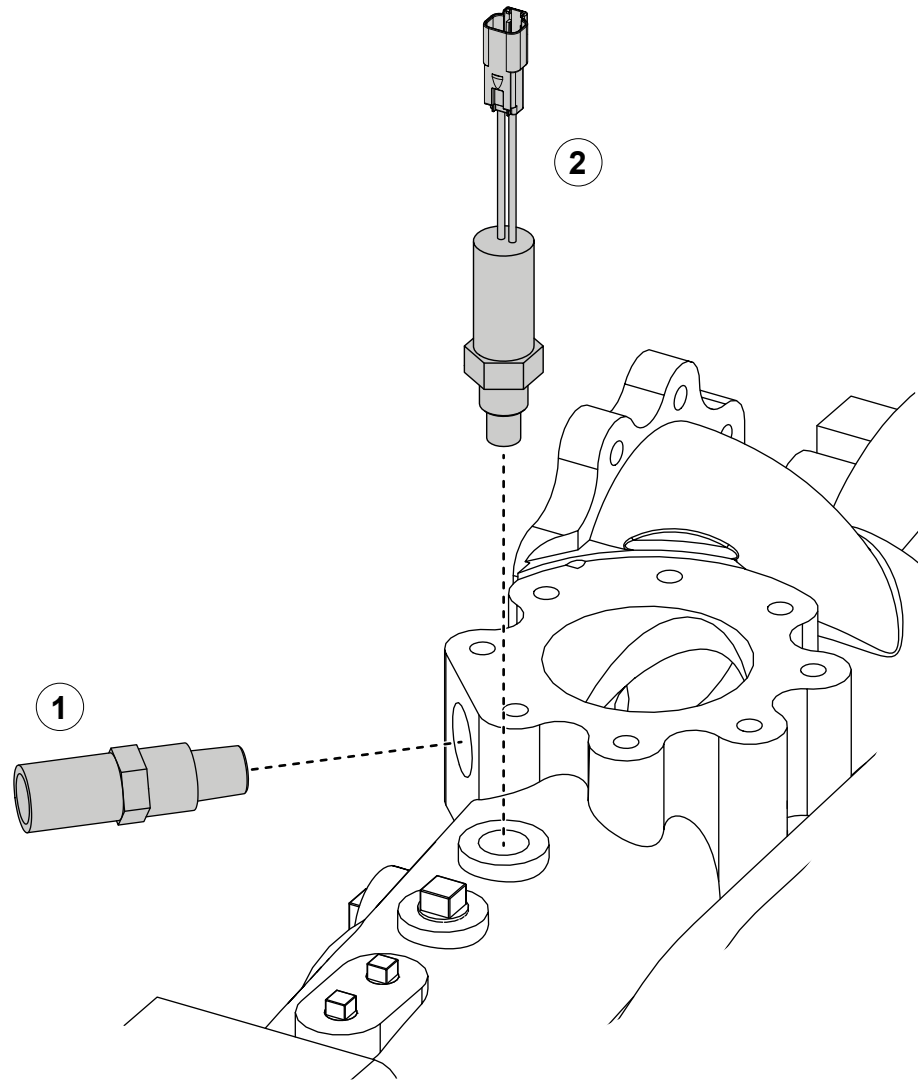

### Locating the Thermal Valve and Switch

Use the illustration and instructions to locate the thermal valve and switch.

**Note:** The illustration may not represent your specific pump. Refer to the SPL for your application to locate the valve and switch. The valve and switch should be installed at the factory.

- 1 Locate the thermal valve on the pump body. Connect the desired amount of piping to the valve outlet to direct hot water either to the ground or back to the water tank.
- 2 Locate the thermal switch on the pump body.

## Installing the OPM—Other Pump Models

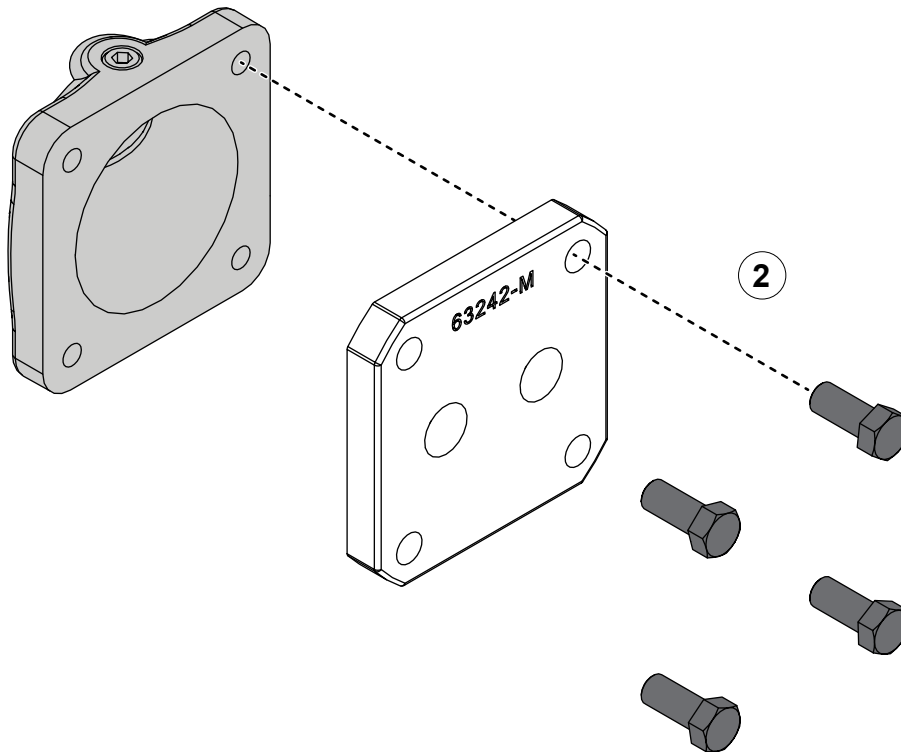
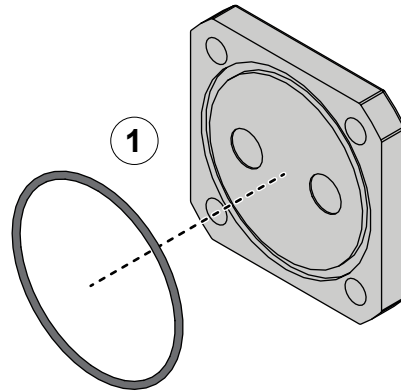

### Mounting the Flange

Use the illustrations and instructions to mount the flange on the pump.

Use the following guidelines to select a suitable location for the flange:

- The flange needs to be as close to the pump discharge as possible.
- To provide adequate overheat protection, the thermal valve and switch need to be close to the impeller.
- There cannot be any valves between the flange and impeller that will restrict water flow to the OPM.
- Rarely, you may need to drill tapped holes into the piping for the valve and switch. Refer to: **"Installing the Thermal Valve and Switch Without a Discharge Fitting" on page 22.**

1 Apply lubricant to the O-ring groove, then install the O-ring into the flange.

2 Use the mounting hardware to install the flange.

## Installing the OPM—Other Pump Models

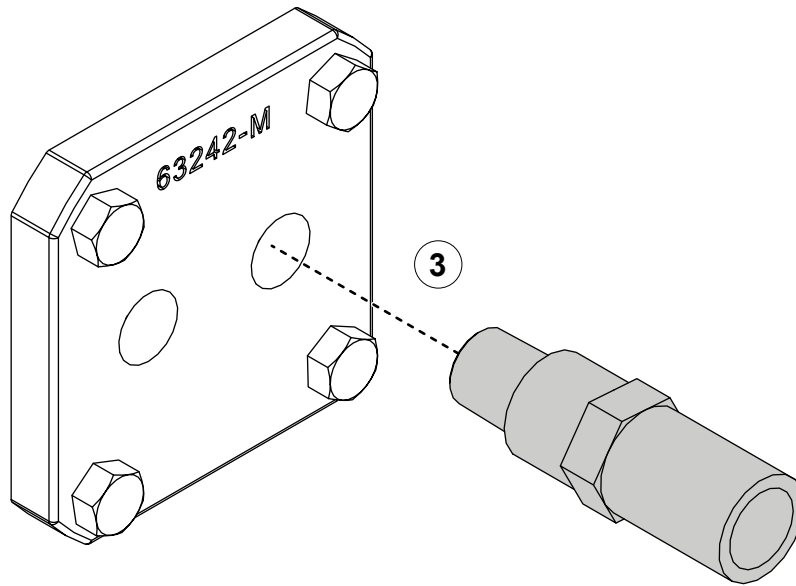

### Installing the Thermal Valve and Switch

Use the illustrations and instructions to install the thermal valve and switch.

- 3 Install the thermal valve into the flange.  
Connect the desired amount of piping to the valve outlet to direct hot water either to the ground or back to the water tank.
- 4 Install the thermal switch into the flange.

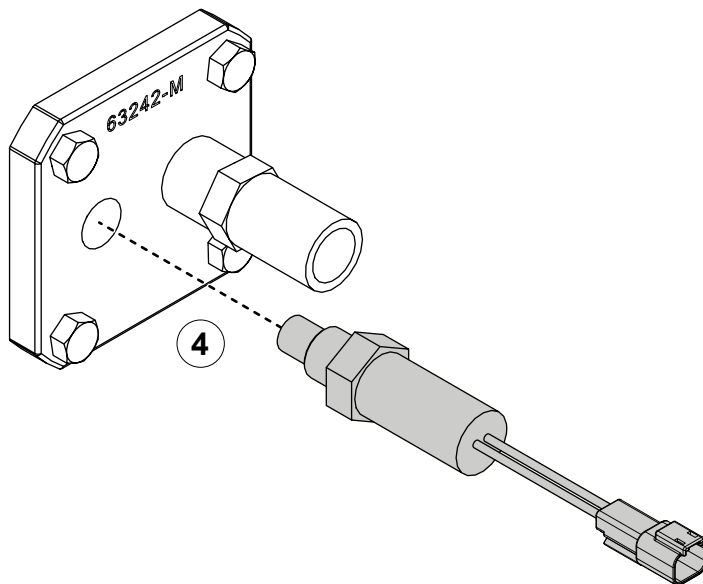

## Installing the Thermal Valve and Switch Without a Discharge Fitting

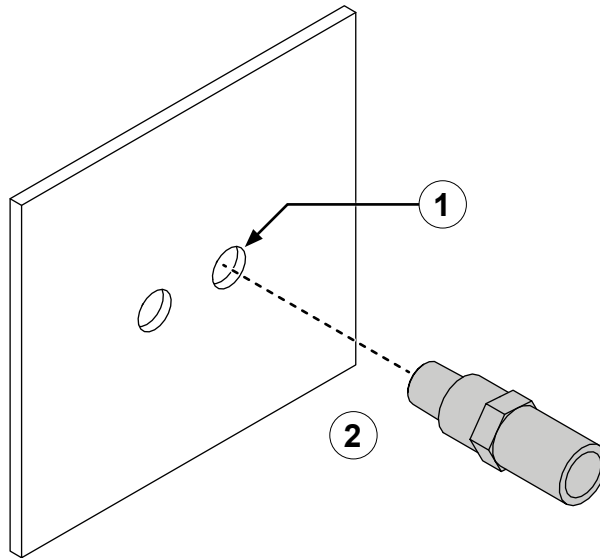

Use the illustration and instructions to install the thermal valve and switch into the piping when no discharge fittings are available.

**Note:** Follow the same guidelines to select a location for the valve and switch as if they were being installed with a flange.

- 1 Drill the 1/2 NPT tapped holes for the thermal valve and switch.

**Note:** Remember that the valve should be parallel to or angled toward the ground.

- 2 Install the thermal valve into the tapped hole. Connect the desired amount of piping to the valve outlet to direct hot water either to the ground or back to the water tank.
- 3 Install the thermal switch into the tapped hole.

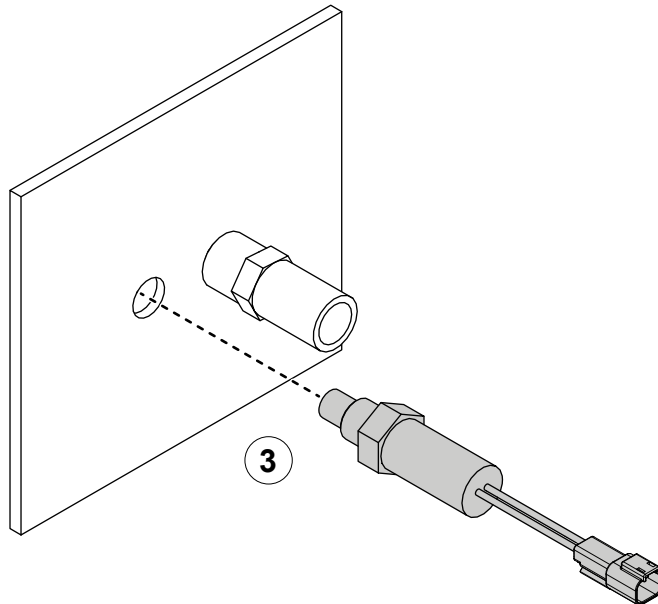

## Installing the OPM—All Pump Models

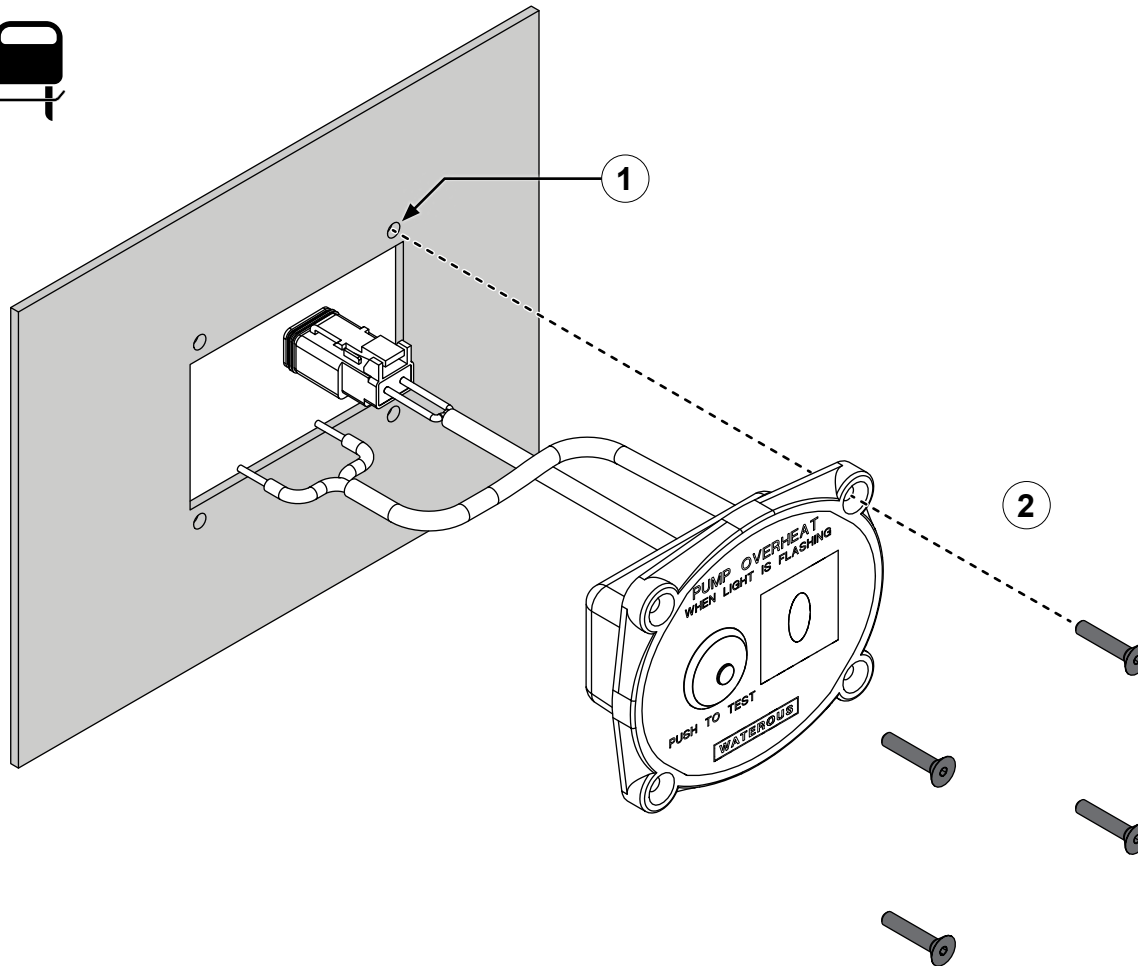

### Mounting the OPM Control Panel

Use the illustration and instructions to mount the OPM control panel on the operator panel.

- 1 Create the cutout and drill the mounting holes for the OPM control panel. For measurements, refer to: **"OPM Control Panel Cutout and Mounting Holes"** on page 17.
- 2 Insert the control panel wiring through the cutout, then use the mounting hardware to install the control panel.

## Installing the OPM—All Pump Models

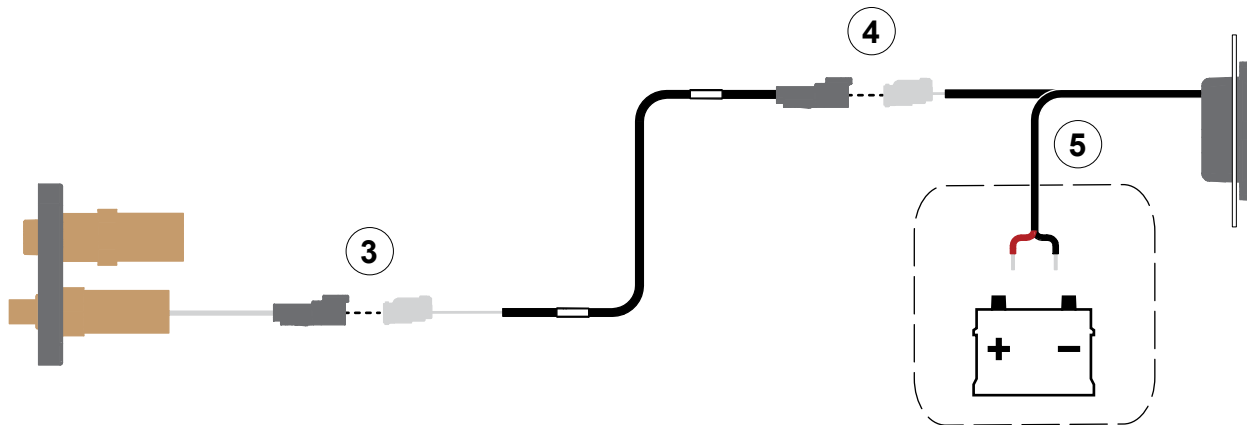

### Connecting the Cables and Wires

Use the illustrations and instructions to connect the OPM cables and wires.

- 3 Connect the extension cable to the thermal switch.
- 4 Connect the extension cable to the OPM control panel.
- 5 Connect the power and ground from the control panel to the appropriate source.
- 6 Press the *TEST* button to test the circuit. The control panel LED should emit light.

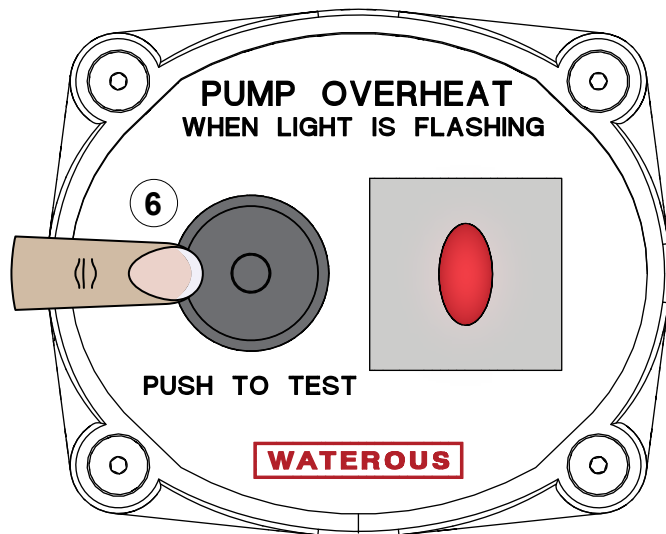



## Installing the Audible Alarm

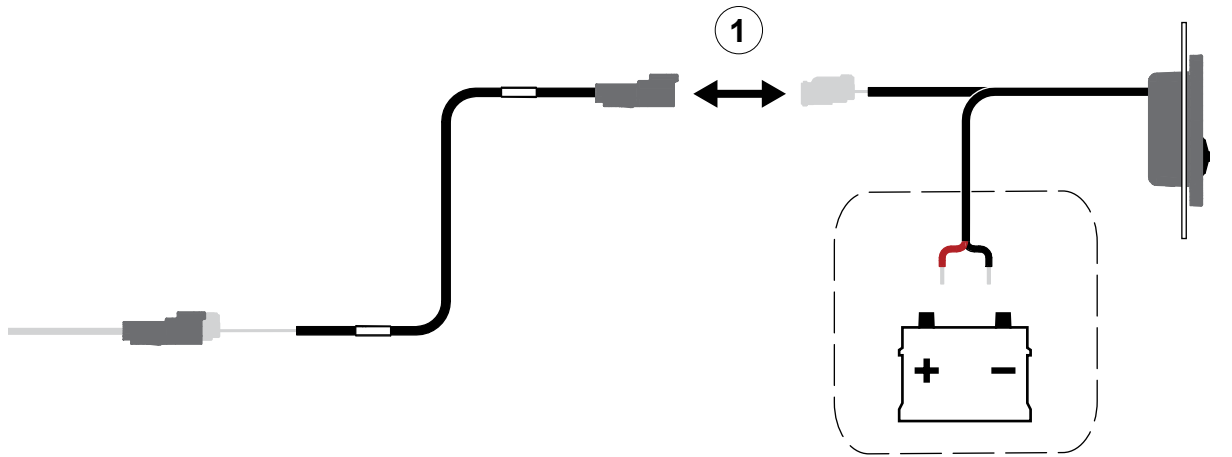

### Connecting the Alarm to the OPM

Use the illustrations and instructions to connect the audible alarm to the OPM assembly.

- 1 Disconnect the extension cable from the OPM control panel.
- 2 Connect the audible alarm cable to the extension cable.
- 3 Connect the audible alarm cable to the control panel cable.

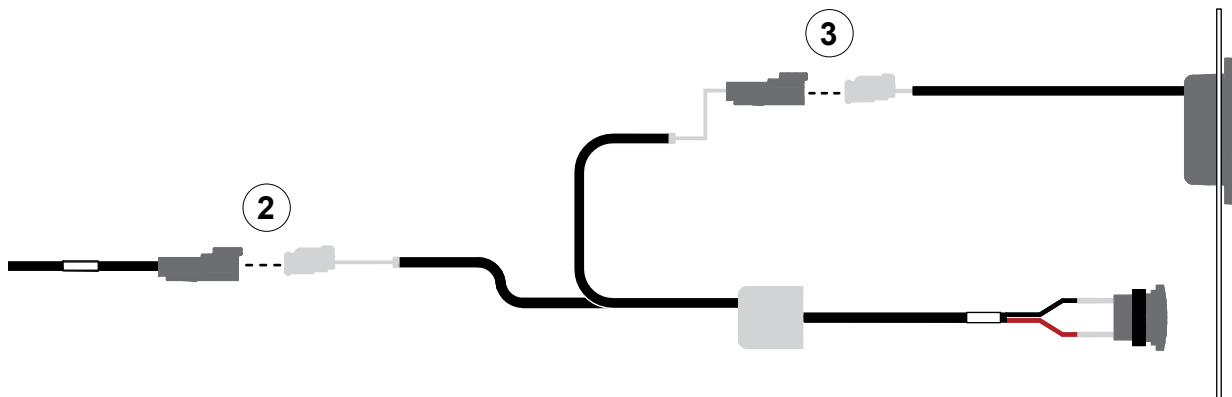

## Installing the Audible Alarm

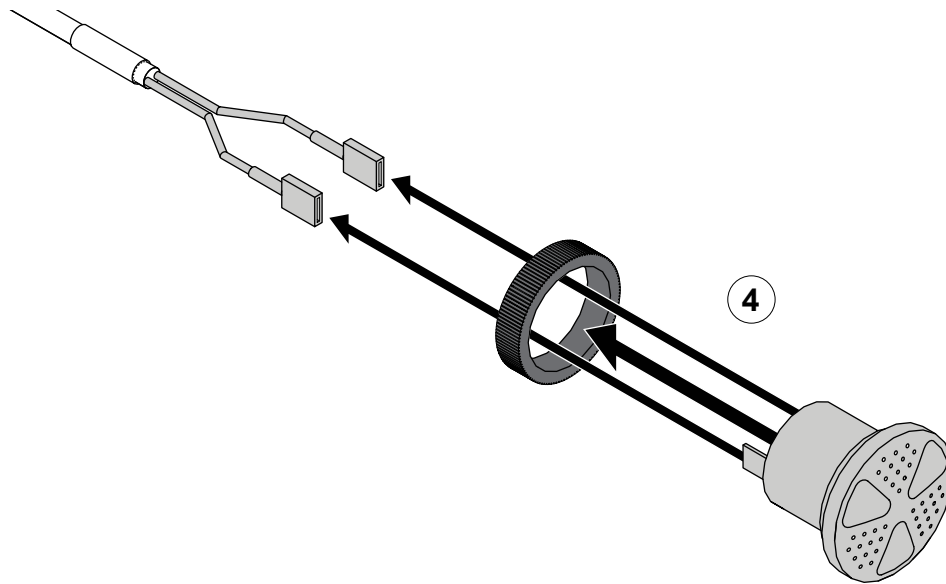

### Mounting the Alarm

Use the illustrations and instructions to mount the audible alarm on the operator panel.

- 4 Disconnect the wire terminals and remove the threaded ring from the alarm.

**Note:** Because of the wire terminals' polarity, make sure to note how the terminals are connected for later in the assembly.

- 5 Create a cutout for the alarm near the OPM control panel. For measurements, refer to: **"Audible Alarm Cutout" on page 18.**

- 6 Insert the alarm into the cutout, then install the threaded ring onto the alarm.

- 7 Connect the wire terminals.

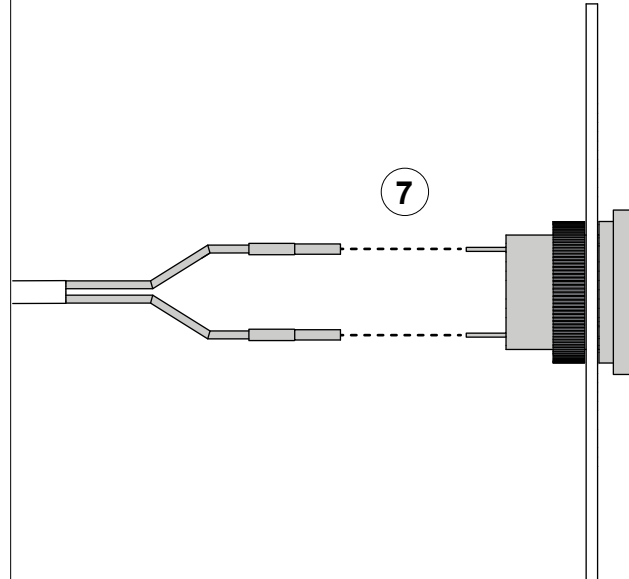
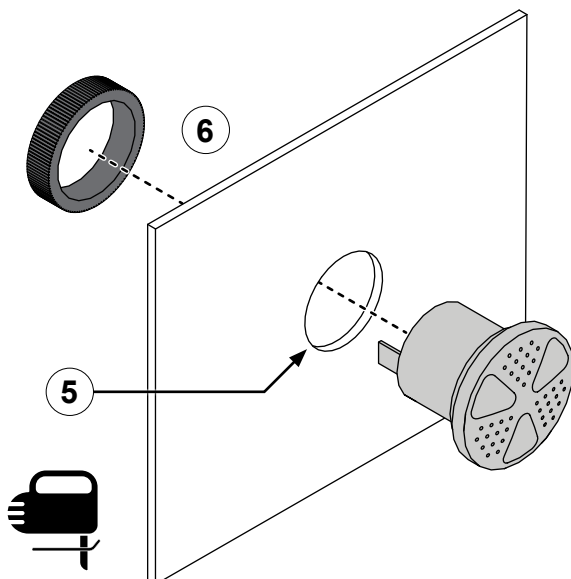

## Installing the Audible Alarm

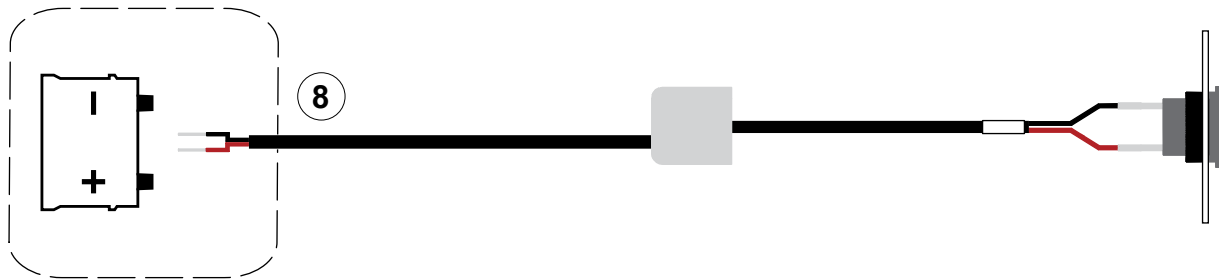

### Connecting the Alarm to Power

Use the illustrations and instructions to connect the audible alarm to power.

- 8 Connect the power and ground from the alarm to the appropriate source.
- 9 Press the *TEST* button to test the circuit. The control panel LED should emit light and the alarm should sound.

**Note:** Alarms purchased prior to September 2021 do not produce sound when the *TEST* button is pressed.

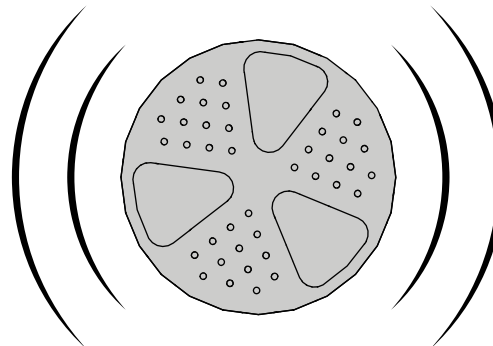
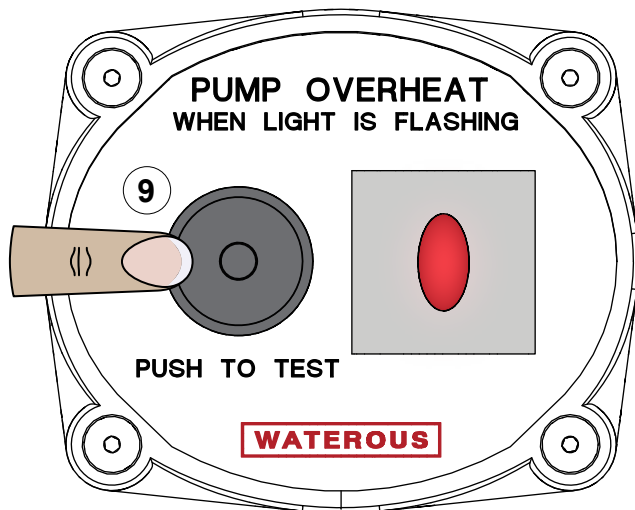

## Operation

---

For CM & CS Series pumps, the thermal valve automatically opens and releases hot water when the temperature reaches 140°F (60°C). For all other pumps, the thermal valve releases hot water when the temperature reaches 120°F (49°C). The thermal switch triggers the control panel LED and audible alarm at 180°F (82°C). If the pump continues overheating, open the discharge and idle the pump with cool water. The valve and switch will automatically close when the water falls at least 10°F (6°C) below opening temperature.

## Maintenance Schedule

---

Press the *TEST* button to check the circuit every 100 hours of pump operation or every 6 months, whichever comes first. The control panel LED should emit light and the alarm should sound.

**Note:** *Alarms purchased prior to September 2021 do not produce sound when the TEST button is pressed.*

## Troubleshooting Guide

Problem	Possible Cause	Solution
Light does not flash properly.	The power is not on.	Turn on power at the appropriate source.
	Loose connections.	Ensure that all cables are properly connected.
	<i>TEST</i> button is not fully depressed.	Press button to full length of travel.
	Power connection has polarities reversed.	Check wiring and polarity.
	Improper voltage.	Check that voltage supplied is between 12–30VDC.
	There is a bad ground between the assembly and chassis.	Repair and/or replace ground wire or ground connection.
	Thermal switch is stuck in open state.	Replace thermal switch.
Light is always flashing.	The LED has failed.	Replace control panel.
	The pump is overheating.	Open the discharge and idle pump with cool water.
	There is a bad ground between the assembly and chassis.	Repair and/or replace ground wire or ground connection.
	Internal short circuit.	Replace control panel.
	Thermal switch is stuck in closed state.	Replace thermal switch.
Alarm does not sound with flashing light.	<i>TEST</i> button is stuck in pressed state.	Jostle the button and/or replace control panel.
	Alarms purchased prior to September 2021 do not produce sound when <i>TEST</i> button is pressed.	Purchase updated control panel and alarm.
	Alarm terminals were installed incorrectly.	Check terminal polarity and install correctly.
	Loose connections.	Ensure that all cables are properly connected.
	The power connection has polarities reversed.	Check wiring and polarity (alarms purchased prior to September 2021 are not polarity protected—may need to be replaced).
Alarm is quiet.	Improper voltage.	Check that voltage supplied is between 12–30VDC.
	Adjustable cover is blocking sound output.	Adjust alarm's cover to achieve desired sound level.
	Improper voltage.	Check that voltage supplied is between 12–30VDC.

## Troubleshooting Guide

Problem	Possible Cause	Solution
Alarm always sounds.	The pump is overheating.	Open the discharge and idle pump with cool water.
	Thermal relief valve stuck closed.	Separate and clean valve components and/or replace the valve.
	There is a bad ground between the assembly and chassis.	Repair and/or replace ground wire or ground connection.
	Internal short circuit.	Replace control panel and/or alarm.
	Thermal switch is stuck in closed state.	Replace thermal switch.
	<i>TEST</i> button is stuck in pressed state.	Jostle the button and/or replace control panel.
Thermal valve leaks.	The pump is overheating.	Open the discharge and idle pump with cool water.
	Sediment lodged in seal.	Remove valve and place in hot water (>140°F) to carefully flush opened valve.
	Leaking through the threaded fitting.	Properly install the threaded NPT into pump.
	Damaged or malfunctioned valve.	Replace valve.
Thermal valve stuck closed.	Sediment buildup.	Separate and clean valve components and/or replace valve.
	Damaged or malfunctioned valve.	Replace valve.

**WATEROUS**

Waterous Company  
125 Hardman Avenue South  
South Saint Paul, MN 55075  
(651) 450-5000  
[www.waterousco.com](http://www.waterousco.com)