

SPECIFICATIONS: ACCESSORIES: POWER SHIFT

“Fast” Positive Shifting without Leaving the Cab



The Waterous Power Shift option permits fast, positive shifting without leaving the cab. In accordance with NFPA 1900, a complete set of indicating lights is standard. These lights indicate when the shift has been complete to PUMP and OK TO PUMP.

Units also include a manual override provision which allows the pump to be engaged manually in case of an electrical or air system failure.

| Power Shift Availability | |
|--------------------------|----------------------------|
| Electric Shift | Pneumatic Shift |
| W Series | C20, C21, C22, C23 Series |
| TML PTO | TC20, TC21, TC22, TC23 PTO |



Optional Air Compressor Kit for Pneumatic Shift

To be used to power pneumatic shift on vehicles without an air system.

| Component | Specifications |
|--|--|
| Air Compressor | <ul style="list-style-type: none"> 12 Volt Permanent Magnetic Motor Duty Cycle: 15% @ 100 PSI Amp Draw: 14 A Min. Ambient Temp: -40° F Max. Ambient Temp: 158° F Stainless Steel Braided Leader Hose Dimensions: 6.00" L x 3.30" W x 4.90" H Net Weight: 3.50 lbs Comes with a 1.5 ft. stainless steel braided leader hose with ¼ NPT swivel male fitting hose end and rubber isolated mounting feet as well as insulated electrical terminals |
| 0.5 Gallon Air Tank | <ul style="list-style-type: none"> Max. Working Pressure: 150 PSI Powder Coated Finish Internally Coated for Corrosion Resistance Dimensions: 6.00 L x 6.50" W x 7.00" H Two ¼" Ports Mounting Hardware Includes Owner's Manual |
| Onboard Air Hookup Kit, 30 amp – 90 PSI On, 125 PSI Off | <ul style="list-style-type: none"> Custom designed to work with Viair Compressors. Each come with a pressure switch with built-in relay, an illuminated dash panel gauge with built-in ON/OFF switch, 20 ft. of positive extension wire, 20 ft. of air delivery tubing to hook up an air tank for convenient onboard air setup. Includes User Manual |

Pneumatic Shift:

The pneumatic shift consists of a double-acting air cylinder and an in-cab control valve for shifting from ROAD to PUMP modes and vice versa. The control valve is equipped with a spring-loaded lockout safety device which locks the control lever in each of the three positions to prevent unintentional movement. With the control lever in the ROAD and PUMP positions, the valve pressurizes one side of the air cylinder with air and exhausts air from the other side. In the center position, the air is exhausted from both sides of the air cylinder to allow for manual shifting. Manual shifting is accomplished by pushing and pulling the air cylinder rod. The pneumatic shift unit contains an interlock features to prevent the pump drive system from being shifted out of the pump engaged pumping mode of operation when the chassis transmission is in pump gear as directed by the NFPA standard.

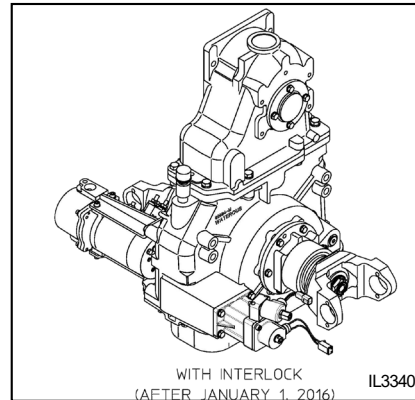

Pneumatic shift on the rear of pump transmission showing double acting air cylinder and indicating light switch. When the rod of the air cylinder is in the IN position, ½" exposed, the transmission is in the ROAD position. When the rod is in the OUT position, 1-1/2" exposed, the transmission is in the PUMP position and a switch is closed for activating the circuit for the green "PUMP ENGAGED" light on the in-cab panel plate.

Electric Shift:

The electric shift uses a proven automotive type actuator to shift from ROAD to PUMP and back. A two position switch is mounted in the cab actuating the shift unit. A spring loaded switch lever lock prevents unintentional movement.

The electric shift manual override uses two controls, one to disengage the shift unit from the pump transmission and the other to manually shift the pump transmission.

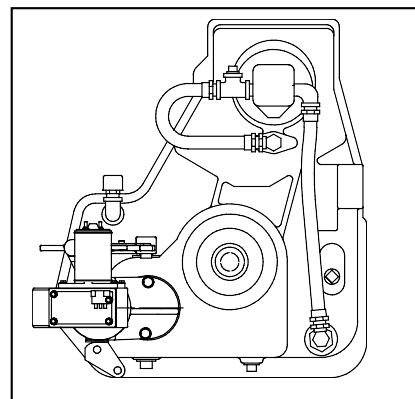

Electric shift on rear of pump transmission - showing shift unit, indicating light switch and shift arm. When the shift arm is moved to the PUMP position it makes contact with the switch and activates the green "PUMP ENGAGED" light circuit.

Industry Leading Sales and Support

When you purchase equipment, not only do you get quality products, you get quality service. Our expert service technicians are the best in the business and they are always happy to answer any service questions you might have.

Sales/Applications Assistance
 Phone: 651-450-5234 (Press 3)
 pumpsales@waterousco.com

Service Assistance
 Phone: 651-450-5200
 Fax: 800-488-1228
 service@waterousco.com