

Form No.	Issue Date	Rev. Date
T-364	10/12/09	9/24/20

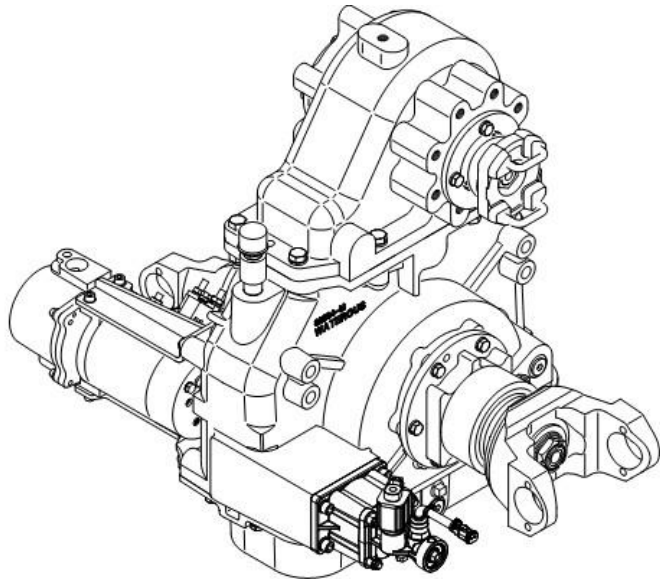

IL3370

### Table of Contents

- Safety Information.....2
- Introduction ..... 3
- General Description ..... 3
- Shifting Instructions:
  - Main P.T.O. Shift ..... 4
  - Optional Manual Override ..... 5
- Maintenance:
  - P.T.O. Shift:
    - Indicating Lights ..... 6
    - Linkage ..... 6
    - Tachometer Readings ..... 6
    - Lubrication ..... 7
- Troubleshooting Guide:
  - P.T.O. Shift..... 8-11
- Component Inspection:
  - P.T.O. Shift..... 12



Read through the safety information and operating instructions carefully before using your Waterous Power Take-Off.



Visit us at [www.waterousco.com](http://www.waterousco.com)

## Safety Information



Read through and communicate safety information to the end user of this Waterous P.T.O.

### **WARNING**

Death or serious personal injury might occur if proper operating procedures are not followed. The pump operator, as well as individuals connecting supply or discharge hoses to the apparatus must be familiar with these pump operating instructions as well as other operating instructions and manuals for the apparatus, water hydraulics and component limitation.

### **WARNING**

#### **Unexpected Truck Movement May result in serious personal injury or death**

Failure to properly shift transmission in accordance to the transmission operating instructions may result in unexpected truck movement which may result in serious personal injury or death.

### **WARNING**

If the truck attempts to move, reduce engine speed to idle. Put truck transmission in NEUTRAL and repeat shifting instructions.

#### **NOTICE:**

When towing, disconnect the drive shaft that connects the pump transmission's rear output (coupling) shaft to the vehicles differential. Failure to do so may result in damage from lack of lubrication.

---

## Introduction

---

The Waterous TC20 Series Power Take-Off (PTO), with a high-strength aluminum case, transmits power from the truck's automatic transmission either to the fire pump or to the drive axle of the truck.

This instruction is divided into five sections:

- General Description
- Shifting Instructions
- Maintenance
- Troubleshooting Guide
- Component Inspection

---

## General Description

---

The bearings and drive chain are lubricated by a splash and passive lubrication system. Lubrication is accomplished when spray from the chain collects in a reservoir in the top of the case. The lubricant flows out of the reservoir and onto the inside surface of the chain. This ensures all pivoting components of the chain receive lubrication.

An electronic tachometer connection protrudes from the tachometer housing at a 45° angle. This tachometer pick-up senses the drive shaft speed.

The shift mechanism within the transmission consists of a sliding internally-toothed collar which is always in engagement with an externally-toothed section of the drive shaft. A fork shifts the collar either to engage it with teeth on the drive sprocket hub (PUMP/PTO) or to engage it with the teeth on the coupling shaft (ROAD).

When in PUMP/PTO position, the shift collar transmits power from the drive shaft through the drive sprocket and the chain to the driven sprocket. The coupling shaft remains stationary.

When in ROAD position, the shift collar transmits power directly from the drive shaft through the coupling shaft to the truck propeller shaft and drive axle(s). In this position, the PTO drive and driven sprockets remain stationary while the drive shaft rotates.

The pneumatic shift unit permits fast, positive shifting without leaving the cab. A shift control, mounted in the cab, activates the shift unit.

Three shift indicator lights are furnished. Two are mounted in the cab and the other is mounted on the operator's panel. These lights indicate to the operator that the shift has been completed into PUMP/PTO position and the truck transmission is in pumping gear.

### TC20 Power Take-Off

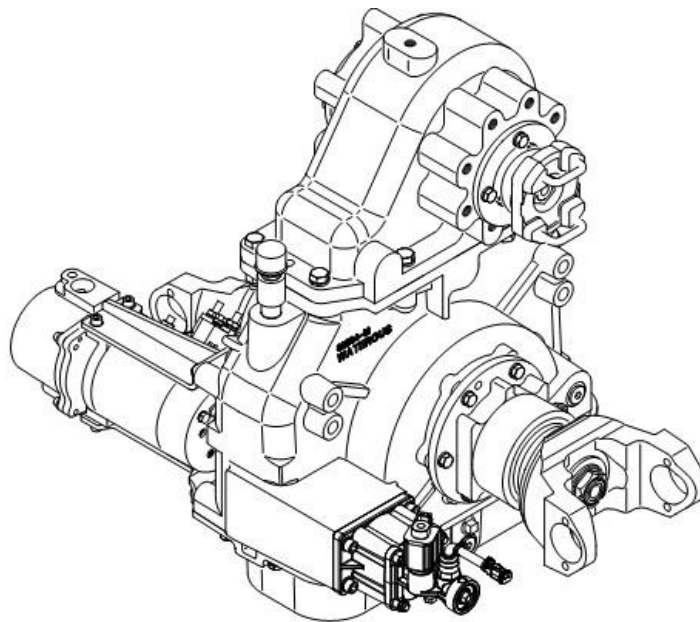

IL3370

# Shifting Instructions

## Main PTO Shift

Two series of Allison automatic transmissions are commonly used in fire trucks. Each series is available with the shift patterns controlled hydraulically or both electronically and hydraulically. This later type is commonly referred to as the ATEC transmission.

In each automatic transmission, either the non-ATEC or the ATEC, certain sequences must occur in proper order after the pump shift control is moved to either PUMP or ROAD position.

Split shaft pump transmissions, automatic transmissions and engines will vary in operation due to manufacturing tolerances, lubrication temperature, etc. This variance in each may or may not affect the ease of completing a full shift into either PUMP or ROAD. Operator training and experience in shifting procedures is a requirement to becoming skilled in a smooth, complete shift into either PUMP or ROAD.

**When the pump shift is activated, the operator may hear a noise associated with the movement of the shift unit. This does NOT mean that the shift has been completed.**

After the shift to pump operation is completed, the green PUMP ENGAGED and OK TO PUMP lights in the cab must be on before leaving the cab to operate the pump from the operators panel. **DO NOT LEAVE THE CAB IF THE GREEN PUMP ENGAGED AND OK TO PUMP LIGHTS ARE NOT ON.**

Some truck builders may install a manual override for the pump shift. The controls are normally installed from the pump transmission to the operators panel.

### WARNING

**Unexpected Truck Movement.  
May result in serious personal injury or death.**

Failure to properly shift transmission in accordance to the transmission operating instructions may result in unexpected truck movement which may result in serious personal injury or death.

### **Shift to PUMP as follows:**

1. Bring truck to complete stop.
2. Reduce engine to idle speed, put truck transmission into **NEUTRAL**.
3. Set truck parking brake.
4. Move pump shift control to **PUMP** position.

**NOTE: Green PUMP ENGAGED light may not illuminate.**

5. Shift truck transmission into pumping gear (**DRIVE**).

### NOTICE

Shifting truck transmission into pumping gear (DRIVE) above engine idle speed may cause damage to the equipment.

6. Green PUMP ENGAGED and OK TO PUMP lights should be on.

### NOTICE

If green PUMP ENGAGED and OK TO PUMP light are not on, momentarily shift truck transmission from pumping gear (DRIVE) to NEUTRAL, then REVERSE, then NEUTRAL, then back into pumping gear (DRIVE). Lights should be on. If lights are not on, repeat procedure.

7. Increase engine speed above idle and hold for a few seconds. Watch speedometer to make sure it shows some value of road speed.

**NOTE: Some fire trucks have a speedometer that will not show a value of road speed in a stationary position.**

### WARNING

If the truck attempts to move, reduce engine speed to idle. Put truck transmission in NEUTRAL and repeat shifting instructions.

8. After leaving truck cab, block wheels using wheel chocks.
9. To confirm that the pump is engaged:
  - THROTTLE READY light on operator's panel is illuminated.
  - Pump discharge pressure registers on gages.
  - Other safety interlocks are activated.

### **Shift to ROAD as follows:**

1. With engine speed at idle, put truck transmission in **NEUTRAL**.
2. When speedometer slows to zero, move pump shift control to **ROAD** position.
3. Engage truck transmission (**DRIVE**).

### NOTICE

If you hear a loud grinding noise when you attempt to move the truck, the shift to ROAD has not been completed. Shift into NEUTRAL, wait for grinding noise to stop and re-engage truck transmission.

If grinding is a common occurrence after Step 3 is performed, it may be prevented by shifting the truck transmission into NEUTRAL, then to REVERSE, back to NEUTRAL and finally to DRIVE.

4. After shifting the truck transmission to **DRIVE**, release the parking brake and move the vehicle forward to confirm a shift to **ROAD** has been completed.

# Shifting Instructions

## Optional Manual Override

Two series of Allison automatic transmissions are commonly used in fire trucks. Each series is available with the shift patterns controlled hydraulically or both electronically and hydraulically. This later type is commonly referred to as the ATEC transmission.

In each automatic transmission, either the non-ATEC or the ATEC, certain sequences must occur in proper order after the pump shift control is moved to either PUMP or ROAD position.

Split shaft pump transmissions, automatic transmissions and engines will vary in operation due to manufacturing tolerances, lubrication temperature, etc. This variance in each may or may not affect the ease of completing a full shift into either PUMP or ROAD. Operator training and experience in shifting procedures is a requirement to becoming skilled in a smooth, complete shift into either PUMP or ROAD.

**When the pump shift is activated, the operator may hear a noise associated with the movement of the shift unit. This does NOT mean that the shift has been completed.**

After the shift to pump operation is completed, the green PUMP ENGAGED and OK TO PUMP lights in the cab must be on before leaving the cab to operate the pump from the operators panel. **DO NOT LEAVE THE CAB IF THE GREEN PUMP ENGAGED AND OK TO PUMP LIGHTS ARE NOT ON.**

If the vehicle builder has provided a means to manually override the pneumatic pump shift, the override control will be located at the operators panel or in the cab. The override control will consist of a rod to the panel or a cable or rod mechanism to the inside of the cab. The rod or cable will be attached to the shift unit on the pump transmission.

**If the pump transmission is equipped with an override, shifting manually is done as follows:**

It is recommended that this procedure be performed using two people; one person in the cab and one at the override control position.

### WARNING

**Unexpected Truck Movement.  
May result in serious personal injury or death.**

Failure to properly shift transmission in accordance to the transmission operating instructions may result in unexpected truck movement which may result in serious personal injury or death.

**Shift to PUMP as follows:**

1. Bring truck to complete stop.
2. Reduce engine to idle speed, put truck transmission in **NEUTRAL**.
3. Set truck parking brake.
4. Move in-cab pump shift control to **CENTER** position.
5. Move manual shift control to **PUMP** position.
6. Move the in-cab pump shift control into the **PUMP** position.

7. Green PUMP ENGAGED light should be on.

### NOTICE

If green PUMP ENGAGED light is not on, momentarily shift truck transmission into REVERSE while keeping pressure on the manual shift rod. Return to NEUTRAL. Green PUMP ENGAGED light should be on.

8. Shift truck transmission into pumping gear (**DRIVE**).

### NOTICE

Shifting truck transmission into pumping gear above engine idle speed may cause damage to the equipment.

9. Green OK TO PUMP light should be on.
10. Increase engine speed above idle and hold for a few seconds. Watch speedometer to make sure it shows some value of road speed.

**NOTE: Some fire trucks have a speedometer that will not show a value of road speed in a stationary position.**

### WARNING

If the truck attempts to move, reduce engine speed to idle. Put truck transmission in NEUTRAL and repeat shifting instructions.

11. After leaving truck cab, block wheels using wheel chocks.
12. To confirm that the pump is engaged:
  - THROTTLE READY light on operator's panel is illuminated.
  - Pump discharge pressure registers on gages. Other safety interlocks are activated.

**Shift to ROAD as follows:**

1. With engine at idle speed, put truck transmission in **NEUTRAL**.
2. When speedometer drops to zero, move in-cab pump shift control into the **CENTER** position.
3. Move manual shift control to **ROAD** position.
4. Move the in-cab pump shift control into the **ROAD** position.
5. Engage truck transmission (**DRIVE**).

### NOTICE

If you hear a loud grinding noise when you attempt to move the truck, the shift to ROAD has not been completed. Shift into NEUTRAL, wait for grinding noise to stop and re-engage truck transmission, while keeping pressure on the manual shift control rod.

6. After shifting the truck transmission to **DRIVE**, release the parking brake and move the vehicle forward to confirm a shift to **ROAD** has been completed.

### PTO Shift:

#### ***Indicating Lights Operation***

Check the operation of the pump shift indicating lights at least weekly as follows:

**NOTE: Block wheels with wheel chocks before beginning.**

1. With the pump in the ROAD position, truck transmission in NEUTRAL and the parking brake engaged, ensure that the PUMP ENGAGED and OK TO PUMP lights in the cab are off.
2. Shift to PUMP following the shifting instructions section of this document.
  - a. Ensure that the green PUMP ENGAGED and OK TO PUMP lights in the cab are on.
  - b. Ensure that the green THROTTLE READY light on the operator's panel is on.
3. Apply the service (foot) brake and release the parking brake.
  - a. Ensure that the green OK TO PUMP light in the cab is off.
  - b. Ensure that the green THROTTLE READY light on the operator's panel is off.
4. Engage the parking brake and shift truck transmission to NEUTRAL.
  - a. Ensure that the green OK TO PUMP light in the cab is off (automatic truck transmission only).
5. Shift to ROAD following the shifting instructions section of this document.
  - a. Ensure that the green PUMP ENGAGED and OK TO PUMP lights in the cab are off.
  - b. Ensure that the green THROTTLE READY light on the operator's panel is off.

#### ***Linkage***

Periodically check all shift linkage for freedom of movement. Clean and lubricate as necessary.

### Tachometer Readings:

The pulse generator generates a frequency proportional to the speed of the rotating shaft. The frequency reading from the sensor is to be used to calculate the rotational speed of the shaft as follows:

Multiply the frequency (Hz) reading from the tachometer sensor by ten to obtain shaft revolutions per minute (rpm).

$$\text{Hz} \times 10 = \text{RPM}$$

# Maintenance

## Lubrication:

1. Check the lubrication fluid level monthly by checking the sight plug or by removing the oil level plug. The fluid should be level with the bottom of the oil level hole.

### NOTICE

Lubrication fluid temperature should not exceed 250 degrees F for extended periods of time.

Premature seal wear and damage will occur.

### NOTICE

Low or excessive lubrication fluid may cause damage.

If lubricant fluid level is low, locate source of leak and repair. If level is high, loosen oil level plug and drain until proper level is reached. If any water drains out, change lubrication fluid and determine source of water leakage and repair.

2. Change lubrication fluid and clean breather and magnetic drain plug annually or after each 100 hours of operation, whichever comes first. Lubrication fluid may be added through the oil level hole or by removing the breather and adding fluid through the opening. Any type of automatic transmission fluid (ATF) may be used. For ambient temperatures over 90° F, SAE 20 oil 300 SSU @ 100° F with service classification SA, SB or SC should be used.
3. Quantity of lubrication fluid if system is completely drained and refilled:  
Approximately 6 quarts of ATF.

## TC20 Oil Level and Oil Fill Locations

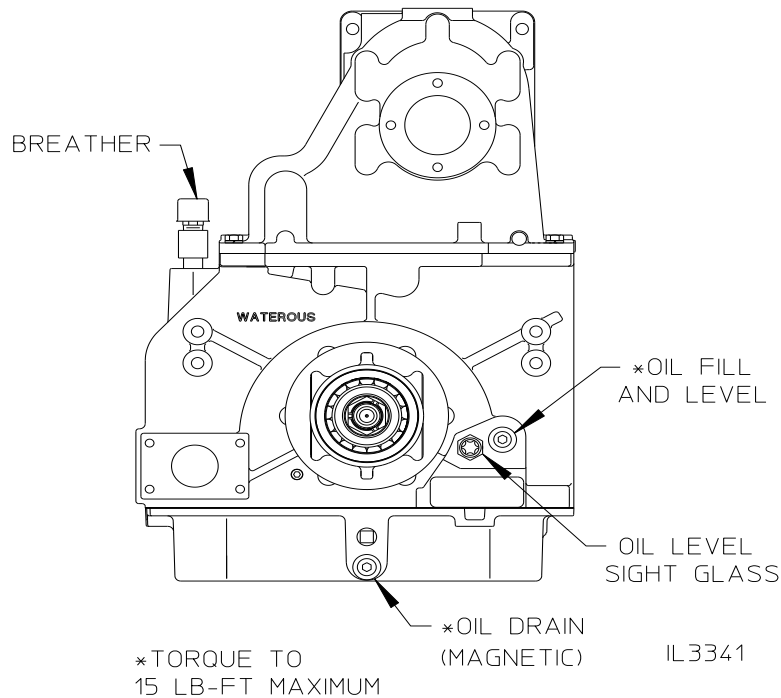

## Towing

When towing, disconnect the drive shaft that connects the pump transmission's rear output (coupling) shaft to the vehicles differential. Failure to do so may result in damage from lack of lubrication.

# Troubleshooting

## **PTO Shift**

It is important to know what to do if you experience shifting problems with your pump. This troubleshooting guide will help you diagnose, isolate and correct problems as they are encountered.

For problems not covered in this guide, or for additional technical assistance, please contact the Waterous Service Department.

Problem	Is the chassis transmission in DRIVE (automatic) or in its pump gear (Manual)?	Possible Cause	Recommended Action
<p style="text-align: center;"><b>PTO won't engage</b></p> <p>PTO shift control is in the PUMP position and PUMP ENGAGED light does not come on.</p>	No	Butt-tooth condition	Place the chassis transmission in Drive (automatic) or in its pumping gear (manual).
	Yes	Malfunctioning shift indicating switch or switch out of adjustment	Replace or adjust the shift indicating switch or bracket.
		Manual override linkage binding	Repair or replace to eliminate binding.
		Excessive driveline torque	Shift the chassis transmission into REVERSE momentarily, then NEUTRAL, then DRIVE. ----- Consider reducing engine idle speed. ----- It may be necessary to contact the chassis transmission manufacturer for assistance.
		Low air pressure to pneumatic shift unit (80 psi min.)	Allow air pressure to build in the system, repair any leaks in the system.
		Leaking pneumatic shift unit.	Repair or replace pneumatic shift unit.
		Malfunctioning air control valve	Repair or replace air control valve.



## Troubleshooting Guide

### PTO Shift (Continued)

Problem	Is the PUMP ENGAGED light on?	Possible Cause	Recommended Action
<p><b>PTO output will not engage and there is a grinding noise emanating from the pump transmission.</b></p> <p>PTO shift control is in the PUMP position and:</p> <p>1. The chassis transmission is in DRIVE (automatic) or in its pumping gear (manual).</p> <p>or</p> <p>2. The chassis transmission is in NEUTRAL.</p>	No	Manual override linkage binding.	Repair or replace to eliminate binding.
		Excessive driveline torque.	Shift the chassis transmission into REVERSE momentarily, then NEUTRAL, then DRIVE. ----- Consider reducing engine idle speed. ----- It may be necessary to contact the chassis transmission manufacturer for assistance.
		Low or no air pressure to pneumatic shift unit (80 psi min.)	Allow air pressure to build in the system, repair any leaks in the system.
		Damage to internal pump transmission shifting components.	See pump transmission inspection instructions.
	Yes	Shift indicating switch is out of adjustment or its bracket is damaged.	Adjust the shift indicating switch or replace the bracket.
		Damage to internal pump transmission shifting components.	See pump transmission inspection instructions.
<p><b>Chassis engine stalls after placing the PTO shift control in PUMP and placing the chassis transmission in DRIVE (automatic) or in its pumping gear (manual).</b></p>	No	Pump transmission has not shifted out of ROAD due to excessive driveline torque.	Shift the chassis transmission into REVERSE momentarily, then NEUTRAL, then DRIVE. ----- Consider reducing engine idle speed. ----- It may be necessary to contact the chassis transmission manufacturer for assistance.
		Damage to internal pump transmission shifting components.	See pump transmission inspection instructions.
	Yes	Seized fire pump.	Repair fire pump as necessary.

## Troubleshooting Guide

### PTO Shift (Continued)

Problem	Is the chassis transmission in DRIVE (automatic) or in its pump gear (Manual)?	Possible Cause	Recommended Action
<b>PUMP ENGAGED</b> light is on but <b>THROTTLE READY</b> light will not illuminate.	No	Chassis transmission not in the proper gear.	Place the chassis transmission in DRIVE (automatic) or in its pumping gear (manual).
	Yes	Parking brake is not applied.	Apply the parking brake.
		Problem with high range lockup or safety interlock systems.	Contact the apparatus manufacturer or consider alternative wiring for high range lockup.
		Problem with chassis transmission or transmission electronic control unit.	Contact the chassis transmission manufacturer for assistance.

Problem	Possible Cause	Recommended Action
<p><b>PTO shift control is in the ROAD position, but the PUMP ENGAGED and/or THROTTLE READY lights stay on.</b></p> <p>Note: Chassis engine may stall if the chassis transmission is placed in DRIVE (automatic) or in its pumping gear (manual).</p>	Shift indicating switch stuck closed.	Replace the shift indicating switch.

## Troubleshooting Guide

### PTO Shift (Continued)

Problem	Possible Cause	Recommended Action
<b>PTO shift control is in the ROAD position and grinding sounds are heard emanating from the pump transmission.</b>	Chassis transmission is in gear when shifting pump.	Place the chassis transmission in NEUTRAL before shifting pump transmission.
	Butt-tooth condition - chassis transmission is in REVERSE.	Place the chassis transmission in DRIVE after shifting pump transmission to ROAD.
	Excessive driveline torque and/or rotation.	Ensure the driveline is not rotating before shifting to ROAD. ----- Consider reducing engine idle speed. ----- It may be necessary to contact the chassis transmission manufacturer for assistance.
	Damage to pump transmission shifting components.	See pump transmission inspection instructions.
<b>Manual PTO shift override control cannot be moved by hand (electric or pneumatic shift functions properly).</b>	Air pressure present on pneumatic shift piston.	Place the shift air control valve in the center position.
	Binding or malfunctioning manual shift linkage.	Repair or replace to eliminate linkage binding.
<b>The chassis engine stalls when the chassis transmission is placed in DRIVE (automatic) after moving the pump shift control to the ROAD position.</b>	Shift indicating switch stuck closed.	Replace the shift indicating switch.
	Problem with chassis transmission or transmission electronic control unit.	Contact chassis transmission manufacturer for assistance.

---

## Component Inspection

---

### PTO Shift:

The following procedures should be followed when a problem with a pump transmission shift component is suspected.

1. Perform a shift force test on the shift unit.
  - a. Place the chassis transmission in NEUTRAL and shut off the engine.
  - b. Set the apparatus parking brake.
  - c. Remove any shift manual override linkage from the shift unit.
  - d. Drain the lubricant from the pump transmission. (Also see step 2).
  - e. Remove the shift unit from the pump transmission.
  - f. Manually slide the shift unit's rod forward and back. Force required to move rod should not be more than 35 lbs.
2. Examine transmission lubricant for metal particles appearing in quantity and/or size which may indicate excessive wear to internal components. Also check the magnetic drain plug for metal particles.
  - a. If there is little or no debris, refill with clean lubricant, reassemble the shift unit and retest.
  - b. If the problem persists or if large quantities or sizes of debris are found, proceed to step 3.
3. Remove the case oil pan from the pump transmission according to the pump transmission overhaul instructions.
4. Inspect the pump transmission shift components including:
  - a. Check for damage to the shift fork and shift shoes.
  - b. Check for damage to the shift fork pivot shoulder screw and the clevis end on the shift unit.
  - c. Check for damage to the engaging teeth on the drive sprocket, coupling shaft and shift collar. Minor burrs found on the teeth of the shift collar, drive sprocket or coupling shaft may be filed clean. If excessive damage is found on any component it should be replaced.
  - d. Check to make sure that all bearings turn freely.
5. Contact Waterous to order any replacement parts or for further assistance.