

## Technical Bulletin No. 142

## C22 Series Transmission

Continuing our innovations and product enhancements, Waterous introduces the new C22 Chain-Drive Transmission that will replace the current C20 Chain-Drive Transmission on orders beginning January 1, 2023. The C22 Generation allows for Waterous pumps/transmission configurations to fit into medium-duty type apparatus. Other features and enhancements are listed below:

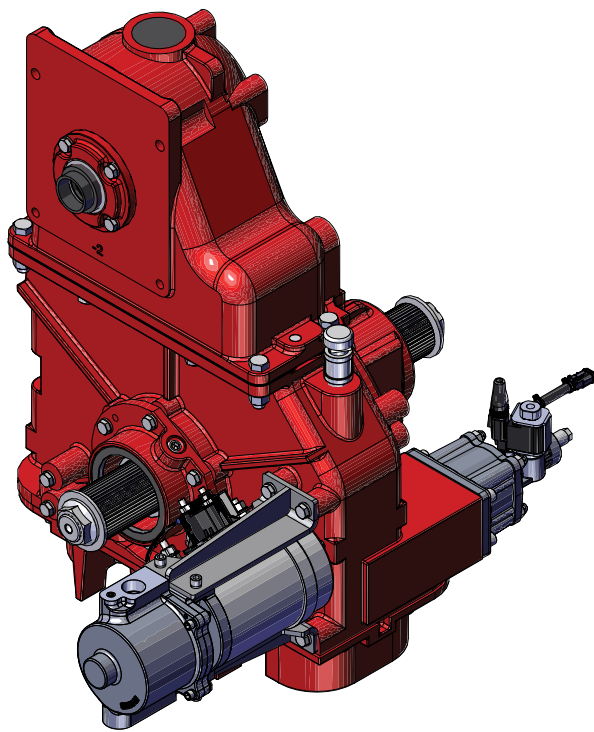

**C20—Previous Generation**

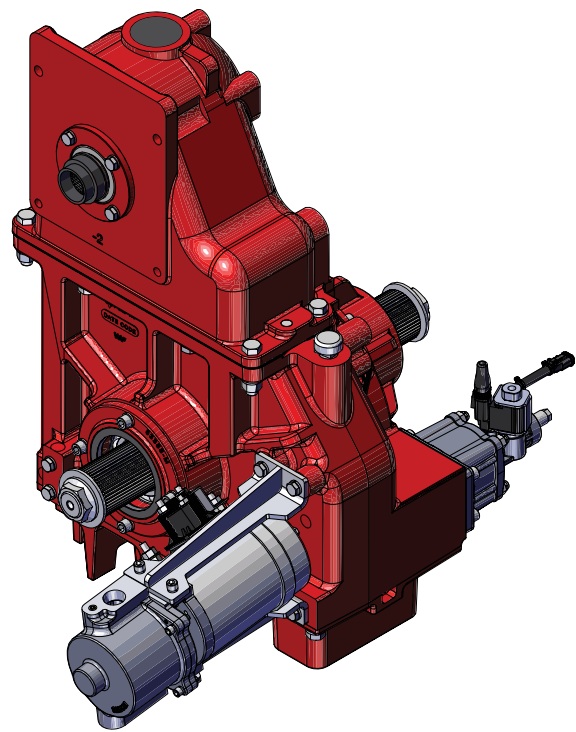

**C22—Current Generation**

### Features and Enhancements:

- Smaller size fits between medium-duty chassis frame rails
- Increased shaft torque rating: Increased from 16,000 to 19,000 ft-lbs
- Higher driveline speed capability using high-speed ball bearings
- Robust housing and improved structural integrity
- Improved mounting application of primer – angled at 8 degrees to improve draining
- Electronic Tachometer option is not available
- Interchangeability between the C20 Transmission using the same chain widths, ratios and drops
- Optional transmission oil cooler kit

# CASE ENVELOPE DIMENSIONS

ALL DIMENSIONS SHOWN AS INCH/MILLIMETER

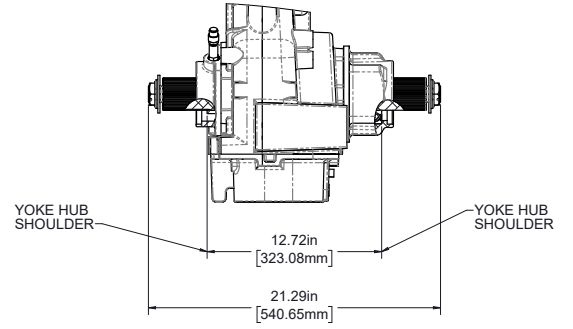
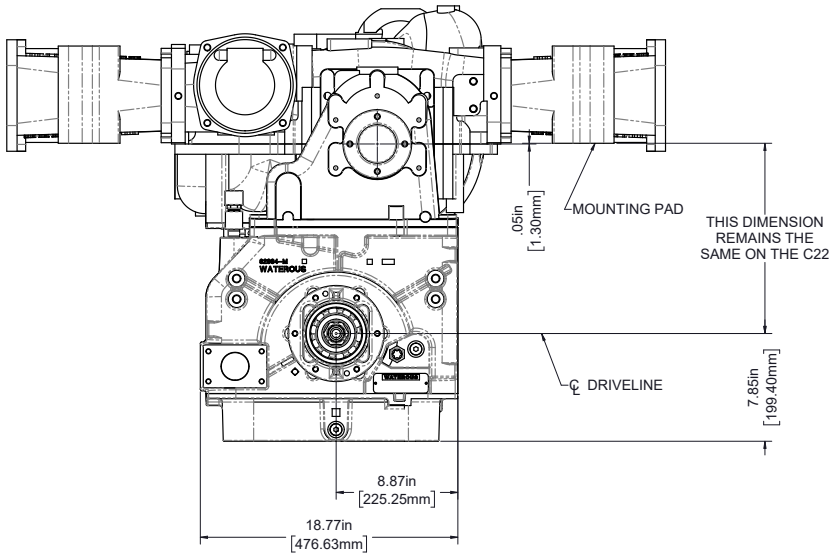

## C20 TRANSMISSION

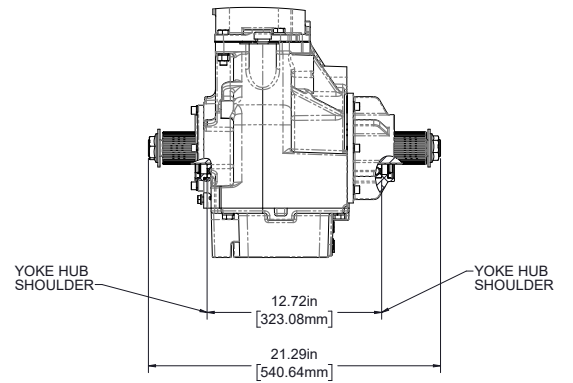
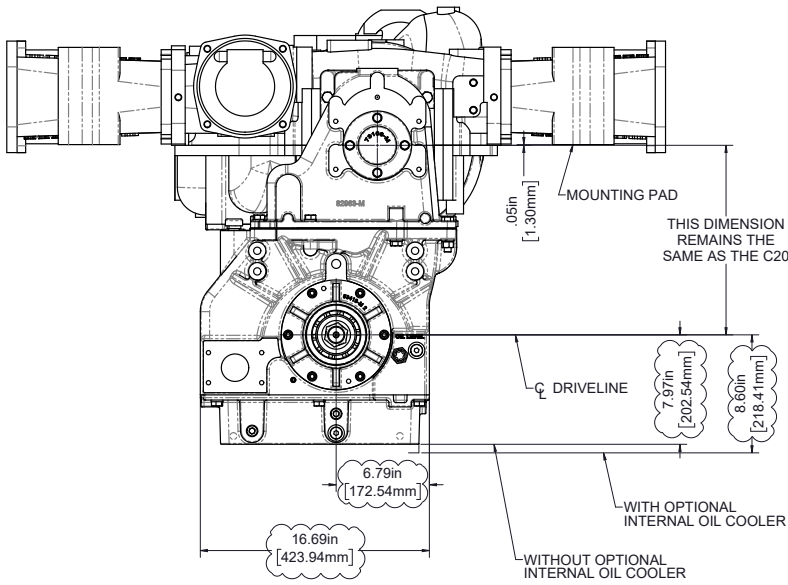

## C22 TRANSMISSION

Dimensional differences are **Ballooned**

# PRIMING PUMP MOUNTING

ALL DIMENSIONS SHOWN AS INCH/MILLIMETER

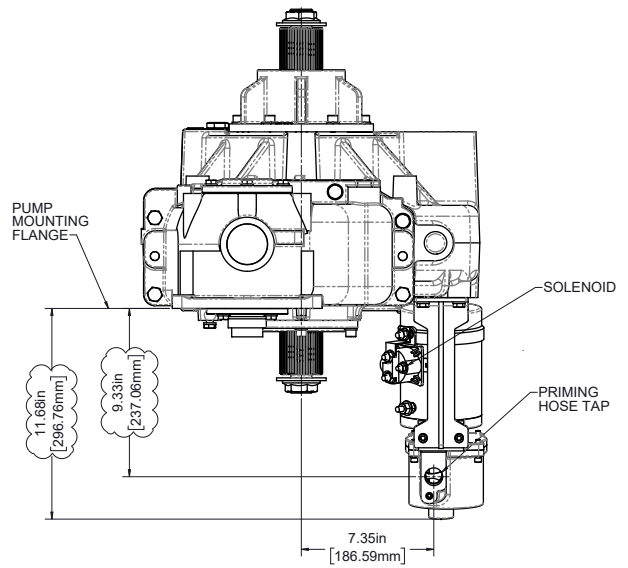
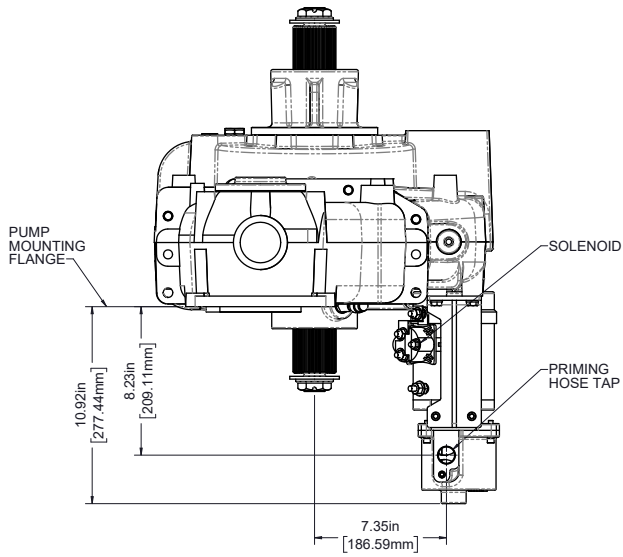
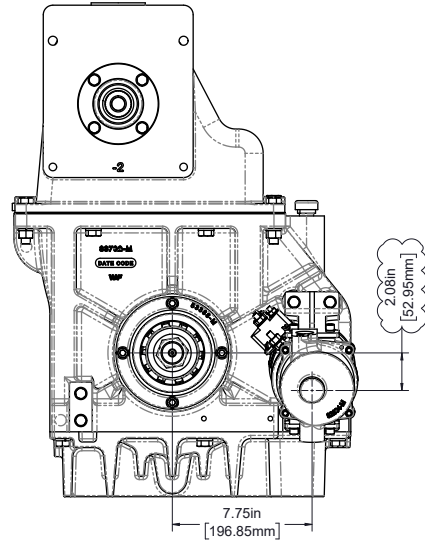
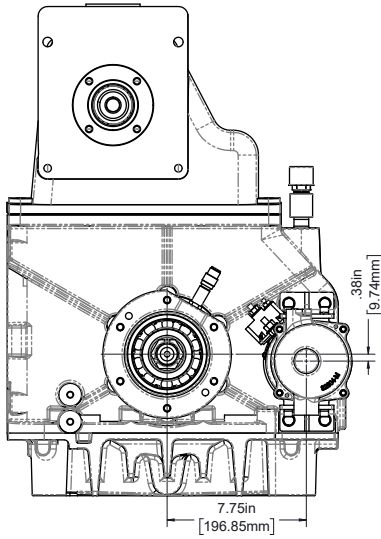

**C20 TRANSMISSION**

**C22 TRANSMISSION**

Dimensional differences are **Ballooned**

# SHIFT UNIT DIMENSIONS

ALL DIMENSIONS SHOWN AS INCH/MILLIMETER

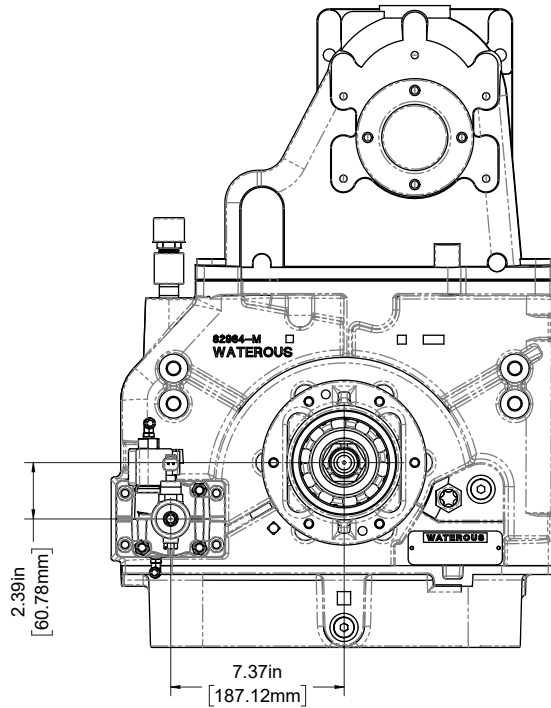
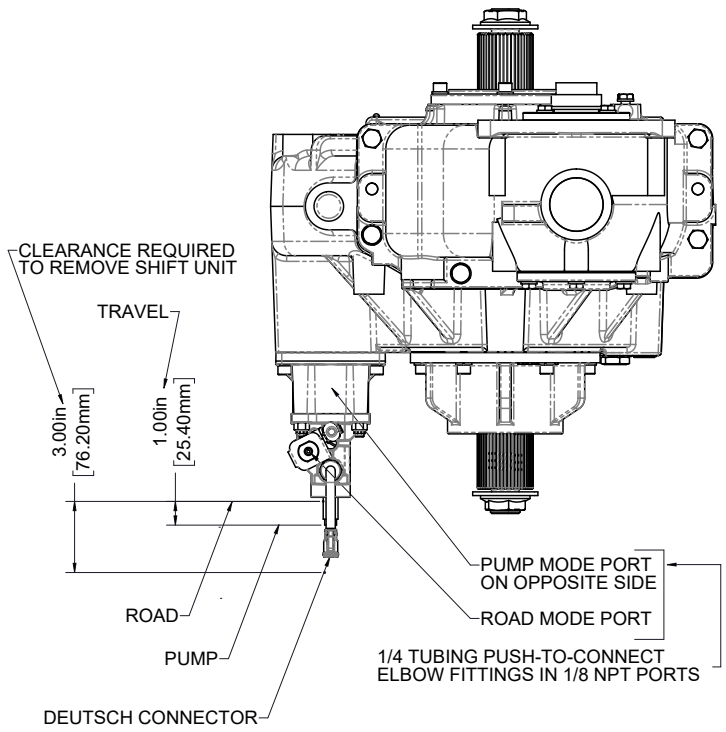
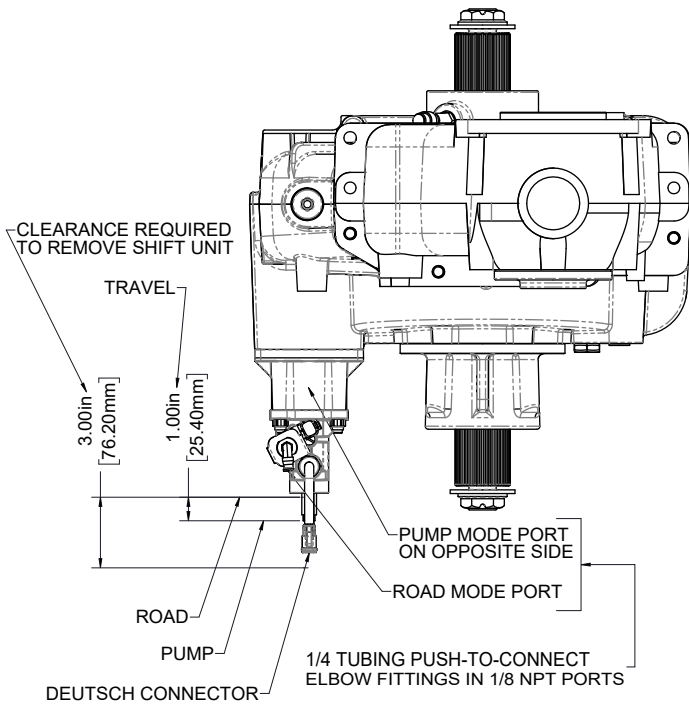

**C20 TRANSMISSION**

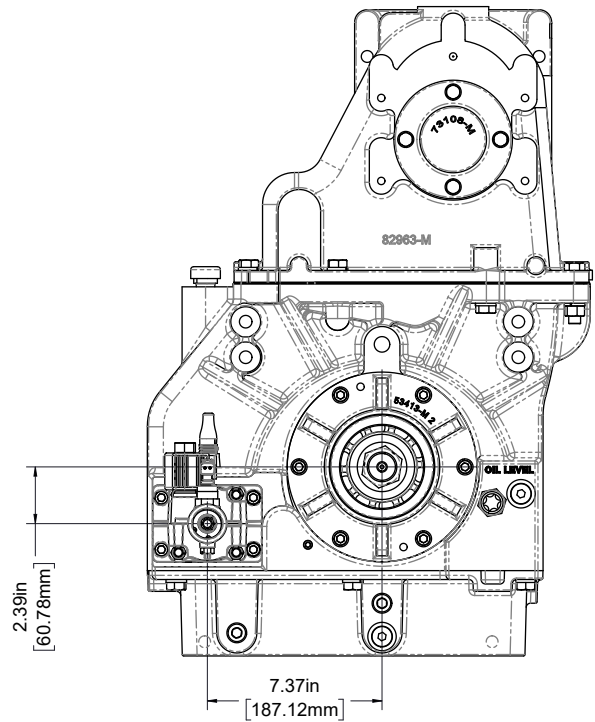

**C22 TRANSMISSION**

Dimensional differences are Ballooned