

**TECHNICAL BULLETIN
No. 0117****Shift Interlock for
C20 Transmission**

All C20 Transmissions ordered after January 1, 2016 will have the new shift interlock.

NFPA requires a shift interlock as directed by new section 16.10.1.4

Where the pump is driven by the chassis engine and automatic transmission through a split shaft PTO, an interlock system shall be provided to prevent the pump drive system from being shifted out of the "pump engaged" pumping mode of operation when the chassis transmission is in pump gear.

Waterous has developed an interlock system for the pneumatic shift on C20 Transmissions. This will be standard equipment on all C20 transmissions on units ordered after January 1, 2016.

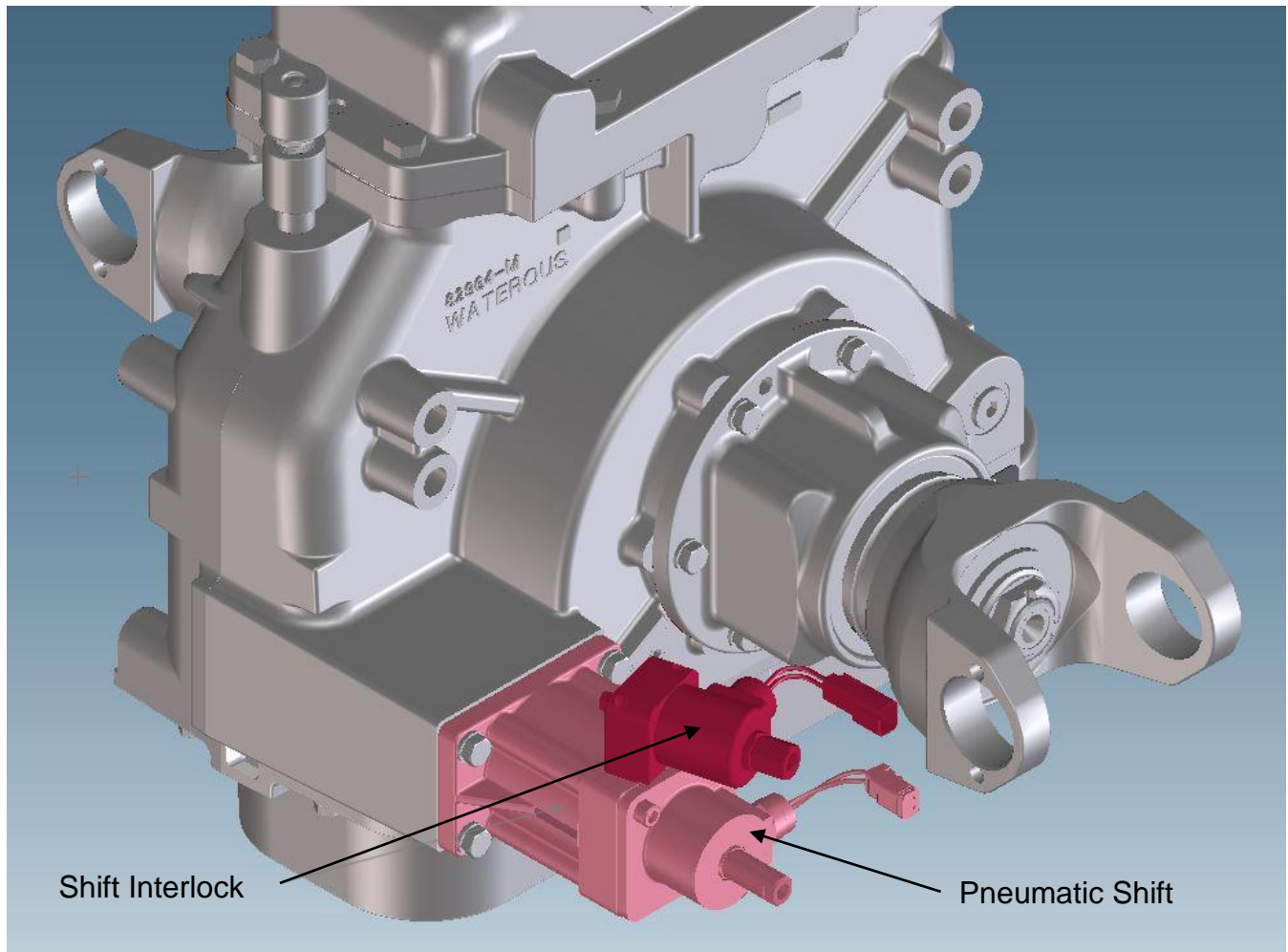

NOTE: The information in this technical bulletin was current at the time of printing. Waterous reserves the right to change this information.