



Document Number	Issue Date	Rev. Date
<b>DPL82078</b>	<b>01/11/96</b>	<b>4/4/19</b>

## Dimensional Drawings Medium Duty T Transmission

Index:

<b>Description</b>	<b>See Page</b>
Models: CP3-5, CP-1, CP-2 and CP-4	2
Models: CLV & CLR	3

AVAILABLE AS FOLLOWS:							
DRIVE	TYPE	MODEL	AVAILABLE BELLHOUSINGS		AVAILABLE RATIOS	AVAILABLE FOR PUMP MODELS:	
			HOUSING ADAPTER	FOR CLUTCH NUMBER		PUMP MODEL	IMPELLER SHAFT TYPE
DIRECT ENGINE MOUNT FOR SAE FLYWHEEL FOR DRIVING-RING TYPE OVER CENTER CLUTCH PER SAE J620	TWO GEAR WITHOUT HYDRAULIC CLUTCH	MEDIUM (MDT) DUTY T	SAE 4	8	1.44, 1.62, 1.97, 2.33, 2.55, 2.79, 2.93, 3.40, 4.00, 4.79	CP3-5	SEPARABLE
			SAE 3 OR 4	10		CP-1, CP-2, CP-4,	ONE-PIECE
			SAE 4	7-1/2			
			SAE 3	11-1/2			
			SAE 5	6-1/2			

NOTE: AVAILABLE WITH EITHER CLOCKWISE OR COUNTERCLOCKWISE INPUT ROTATION

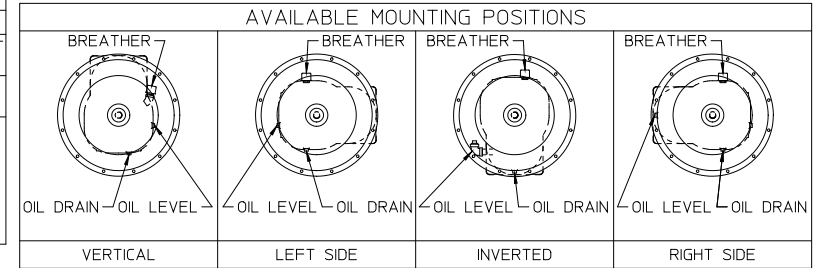

SAE BELLHOUSING					D	SAE FLYWHEEL				OPTIONAL DRIVE PLATE		DRIVE SHAFT	
SIZE	A	B	C	F		CLUTCH NUMBER	E	G	K	PART NUMBER	TORQUE RATING	H	J
3	16.125/409.58	17.750/450.85	16.875/428.63	12	7.250 184.15	10	2.12/53.85	3/8-16	3.940 100.08	V 2272	850 FT-LB / 1153 JOULES	1.1805	1-1/2-10 SAE
4	14.250/361.95	15.875/403.23	15.000/381.00			11-1/2	1.56/39.62			V 2461	425 FT-LB / 576 JOULES	1.1800	
3	16.125/409.58	17.750/450.85	16.875/428.63			8	2.44/61.97	V 2852	N/A	1.1800			
4	14.250/361.95	15.875/403.23	15.000/381.00			7-1/2	1.19/30.23	V 4128		29.98			
5	12.375/314.32	14.000/355.60	13.125/333.38	8	6.25 158.75	6-1/2	1.19/30.23	5/16-18	2.810 71.40	V 2865	.7868 .7858 19.98 19.96	1-15T INVOLUTE	

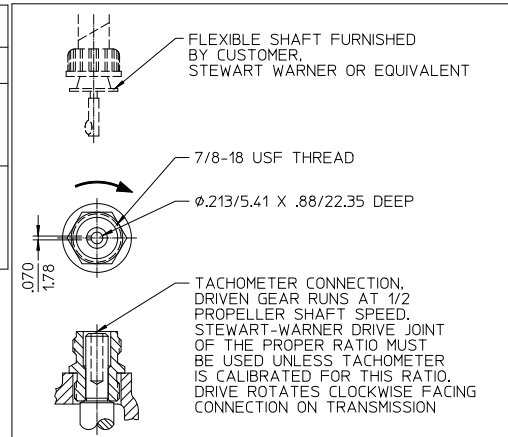

DETAIL A  
MECHANICAL DRIVE TACHOMETER CONNECTION

NOTES:  
1. TACHOMETER CONNECTIONS CANNOT BE FURNISHED FOR THE FOLLOWING TRANSMISSION MOUNTING POSITIONS:  
INVERTED - EITHER INPUT ROTATION  
LEFT SIDE - CLOCKWISE INPUT ROTATION  
RIGHT SIDE - COUNTERCLOCKWISE INPUT ROTATION  
2. TACHOMETER CONNECTION NOT AVAILABLE WITH TRANSMISSION FOR PUMP MODELS CLR & CLV.

(G) TAPPED HOLE SIZE IN FLYWHEEL  
USE GRADE 8 SCREWS FOR CLUTCHES 8, 10, & 11-1/2  
USE GRADE 5 SCREWS FOR 6-1/2 CLUTCH  
(8) REQ'D FOR CLUTCH SIZES 10 & 11-1/2  
(6) REQ'D FOR CLUTCH SIZES 8 & 6-1/2

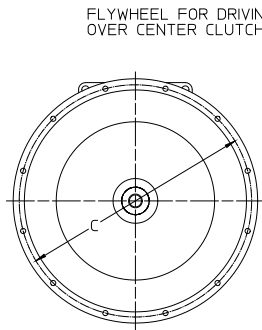

ALL DIMENSION SHOWN IN INCH/MILLIMETER

( INCH / MILLIMETER )

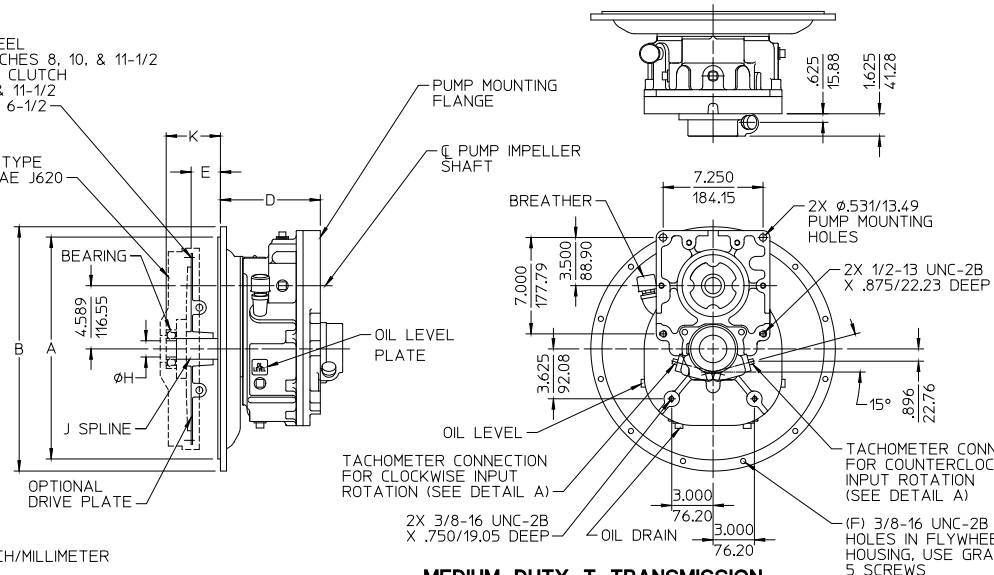

**MEDIUM DUTY T TRANSMISSION**  
**FOR PUMP MODELS: CP3-5, CP-1, CP-2 AND CP-4**  
TWO-GEAR WITHOUT HYDRAULIC CLUTCH, DIRECT ENGINE MOUNT

MEDIUM DUTY T  
DPL82078  
WATEROUS COMPANY  
SOUTH ST. PAUL, MN 55075  
PAGE 2 OF 3

AVAILABLE AS FOLLOWS:							
DRIVE	TYPE	MODEL	AVAILABLE BELLHOUSINGS		AVAILABLE RATIOS	AVAILABLE FOR PUMP MODELS:	
			HOUSING ADAPTER	FOR CLUTCH NUMBER		PUMP MODEL	IMPELLER SHAFT TYPE
DIRECT ENGINE MOUNT FOR SAE FLYWHEEL FOR DRIVING-RING TYPE OVER CENTER CLUTCH PER SAE J620	TWO GEAR WITHOUT HYDRAULIC CLUTCH	MEDIUM DUTY T (MDT)	SAE 4	8	1.44, 1.62, 1.97, 2.33, 2.55, 2.79, 2.93, 3.40, 4.00, 4.79	CLR, CLV	ONE-PIECE
			SAE 3 OR 4	10			
			SAE 3	11-1/2			
			SAE 5	6-1/2			

NOTE: AVAILABLE WITH EITHER CLOCKWISE OR COUNTERCLOCKWISE INPUT ROTATION

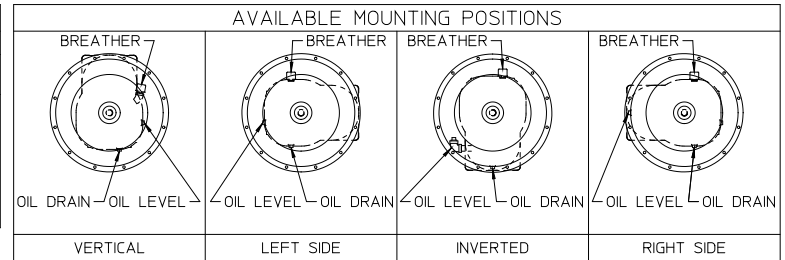

SAE BELLHOUSING					D	SAE FLYWHEEL			DRIVE PLATE		DRIVE SHAFT	
SIZE	A	B	C	F		CLUTCH NUMBER	E	G	PART NUMBER	TORQUE RATING	H	J
3	16.125/409.58	17.750/450.85	16.875/428.63	12	7.250 184.15	10	2.12/53.85	3/8-16	V 2272	850 FT-LB / 1153 JOULES	1.1805	1-1/2-10 SAE
4	14.250/361.95	15.875/403.23	15.000/381.00			11-1/2	1.56/39.62		V 2461	425 FT-LB / 576 JOULES	1.1800	
3	16.125/409.58	17.750/450.85	16.875/428.63			8	2.44/61.97		V 2852	N/A	29.98	
4	14.250/361.95	15.875/403.23	15.000/381.00								29.97	
5	12.375/314.32	14.000/355.60	13.125/333.38	8	6.25 158.75	6-1/2	1.19/30.23	5/16-18	V 2865	N/A	.7868 .7858 19.98 19.96	1-15T INVOLUTE

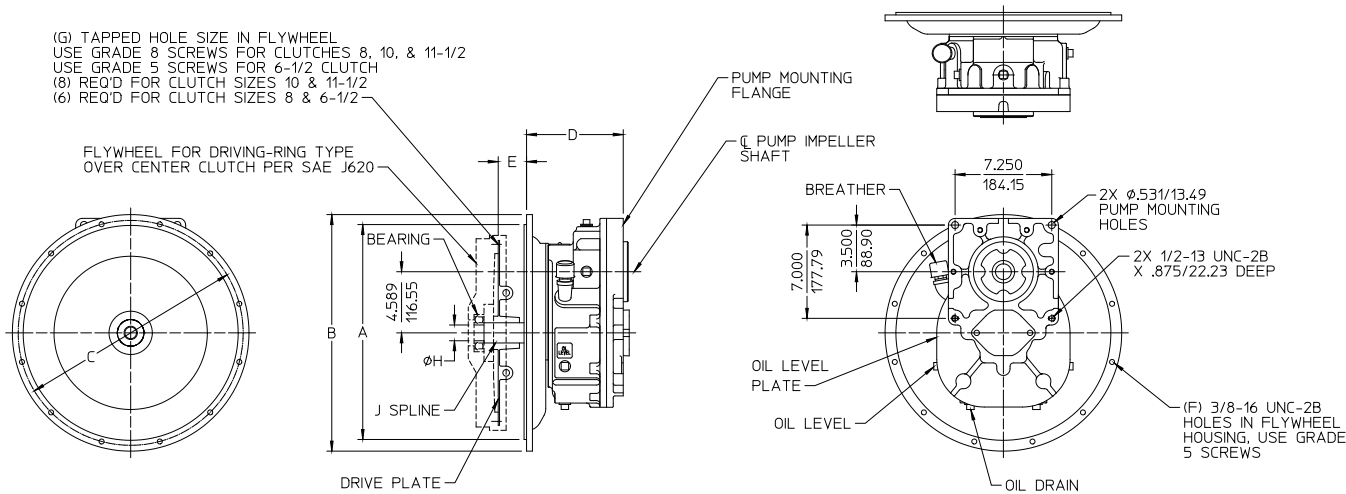

NOTE:  
1. TACHOMETER CONNECTION NOT AVAILABLE

ALL DIMENSION SHOWN IN INCH/MILLIMETER  
 ( INCH / MILLIMETER )

**MEDIUM DUTY T TRANSMISSION  
 FOR PUMP MODELS: CLV AND CLR**

TWO-GEAR WITHOUT HYDRAULIC CLUTCH, DIRECT ENGINE MOUNT

MEDIUM DUTY T  
DPL82078  
WATEROUS COMPANY  
SOUTH ST. PAUL, MN 55075  
PAGE 3 OF 3