

Dimensional Drawings for Intake Relief Valve

<b>Mounting Type</b>	<b>See Page</b>
Pilot Valve	1
Pump Mounted Relief Valve with Extension (On Intake Fitting Behind Butterfly Valve)	2
Pump Mounted Relief Valve Without Extension (On Intake Nipple in Front of Butterfly Valve)	3
Separately Mounted Relief Valve	4

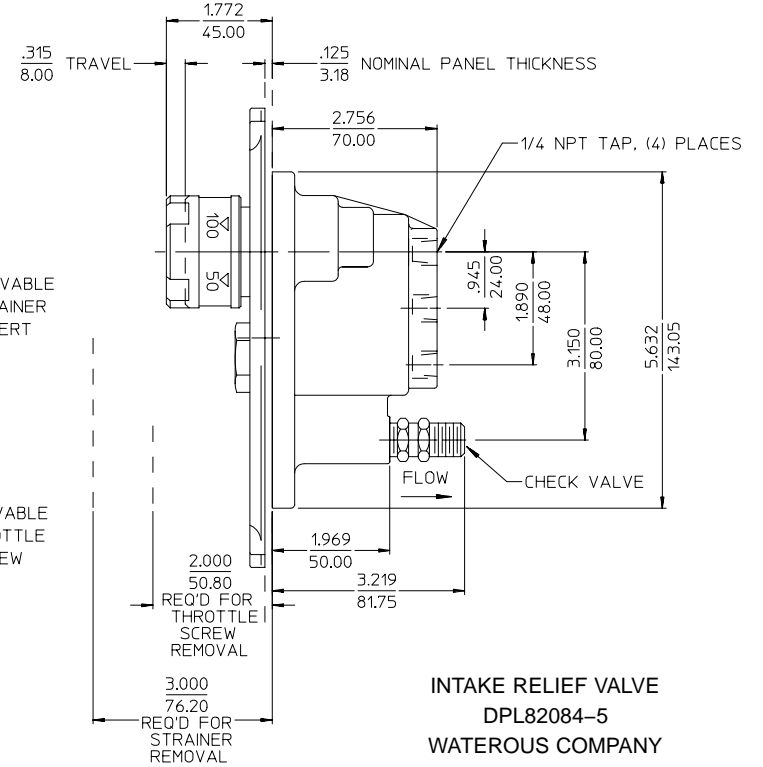

- NOTES:
1. SEE SHEET 2 & 3 FOR PUMP MOUNTED RELIEF VALVE DETAILS.
  2. SEE SHEET 4 FOR SEPARATELY MOUNTED RELIEF VALVE DETAILS.

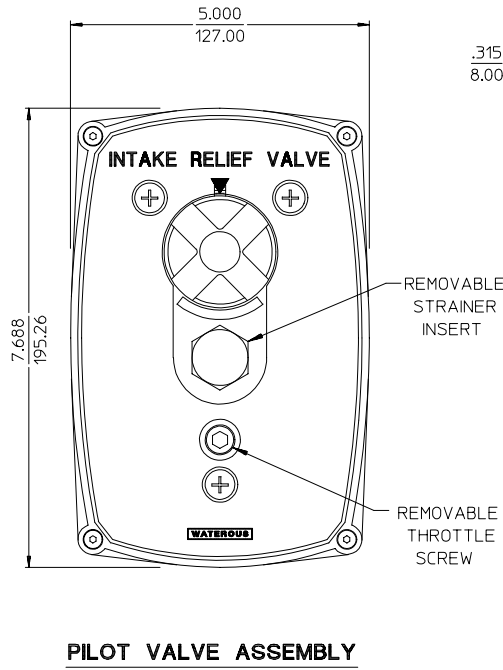
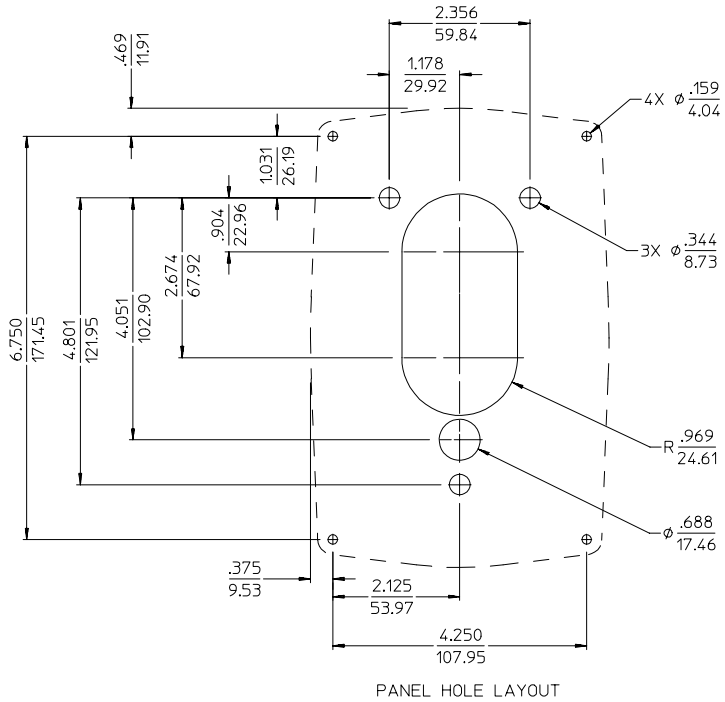
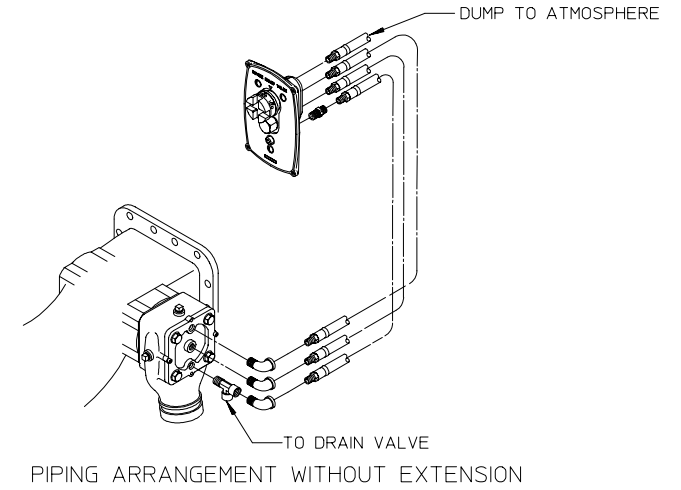
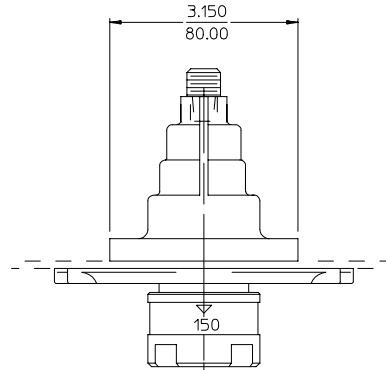
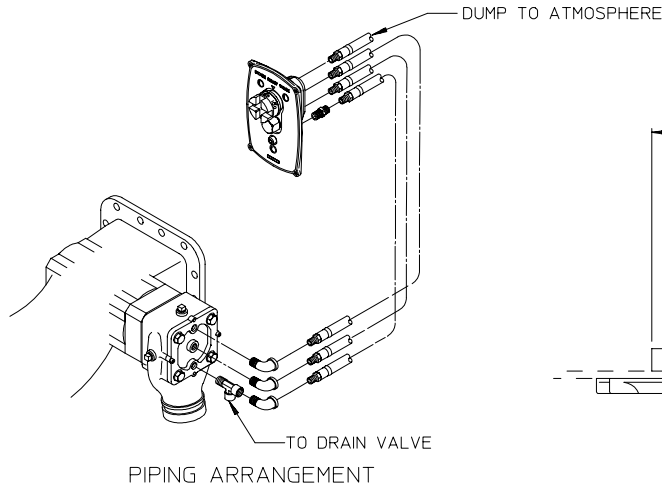
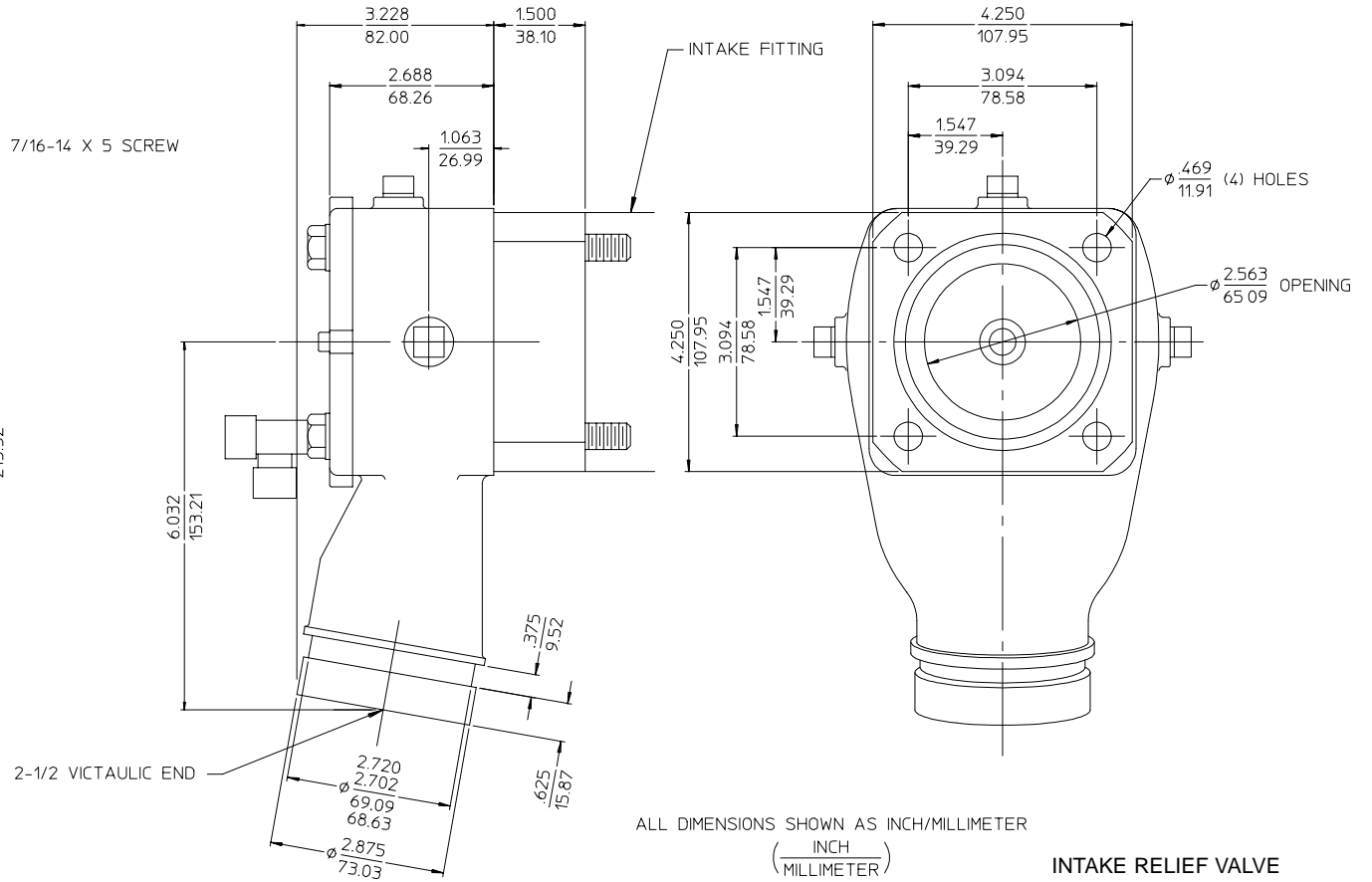
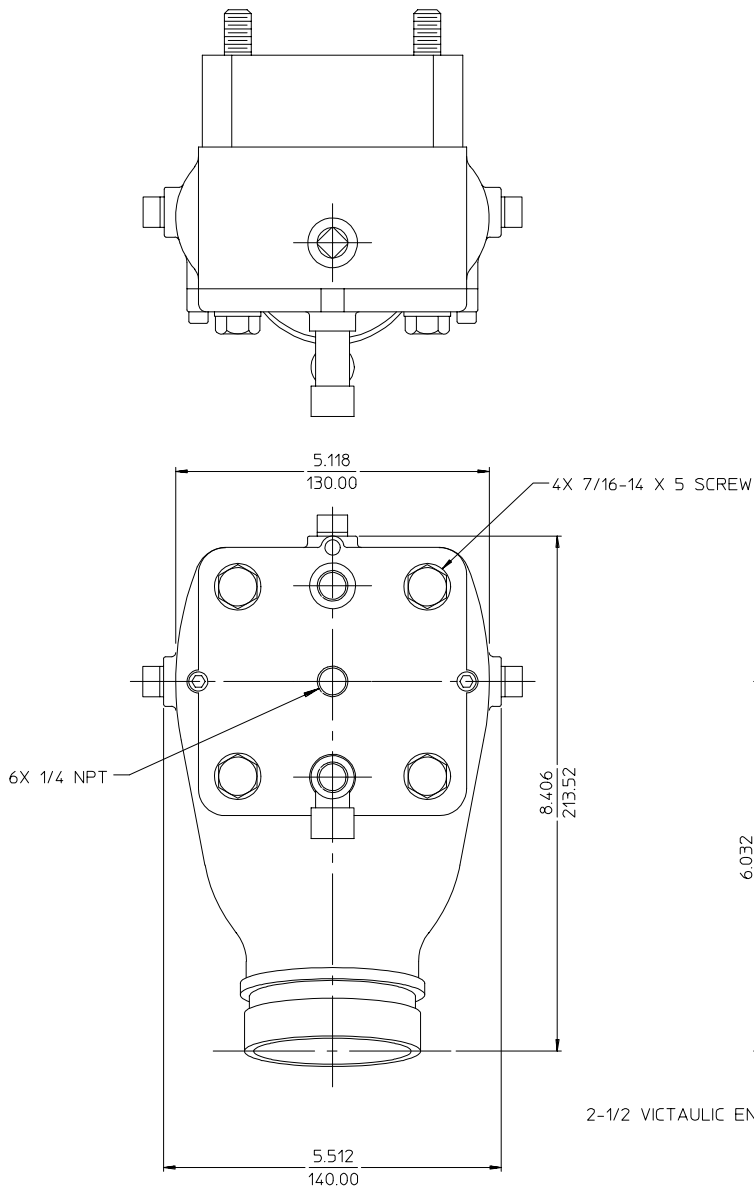

ALL DIMENSIONS SHOWN AS INCH/MILLIMETER  
 ( INCH )  
 ( MILLIMETER )

NOTES:  
 1. SEE PAGE 1 FOR PILOT VALVE ASSEMBLY DETAILS.

**PUMP MOUNTED RELIEF VALVE WITH EXTENSION**  
 (NORMALLY MOUNTED ON INTAKE FITTING BEHIND BUTTERFLY VALVE)

**INTAKE RELIEF VALVE**  
 DPL82084-5  
 WATEROUS COMPANY  
 SOUTH ST. PAUL, MN 55075  
 REL: 8/96 PAGE 2 OF 4 REV: 07/11/06

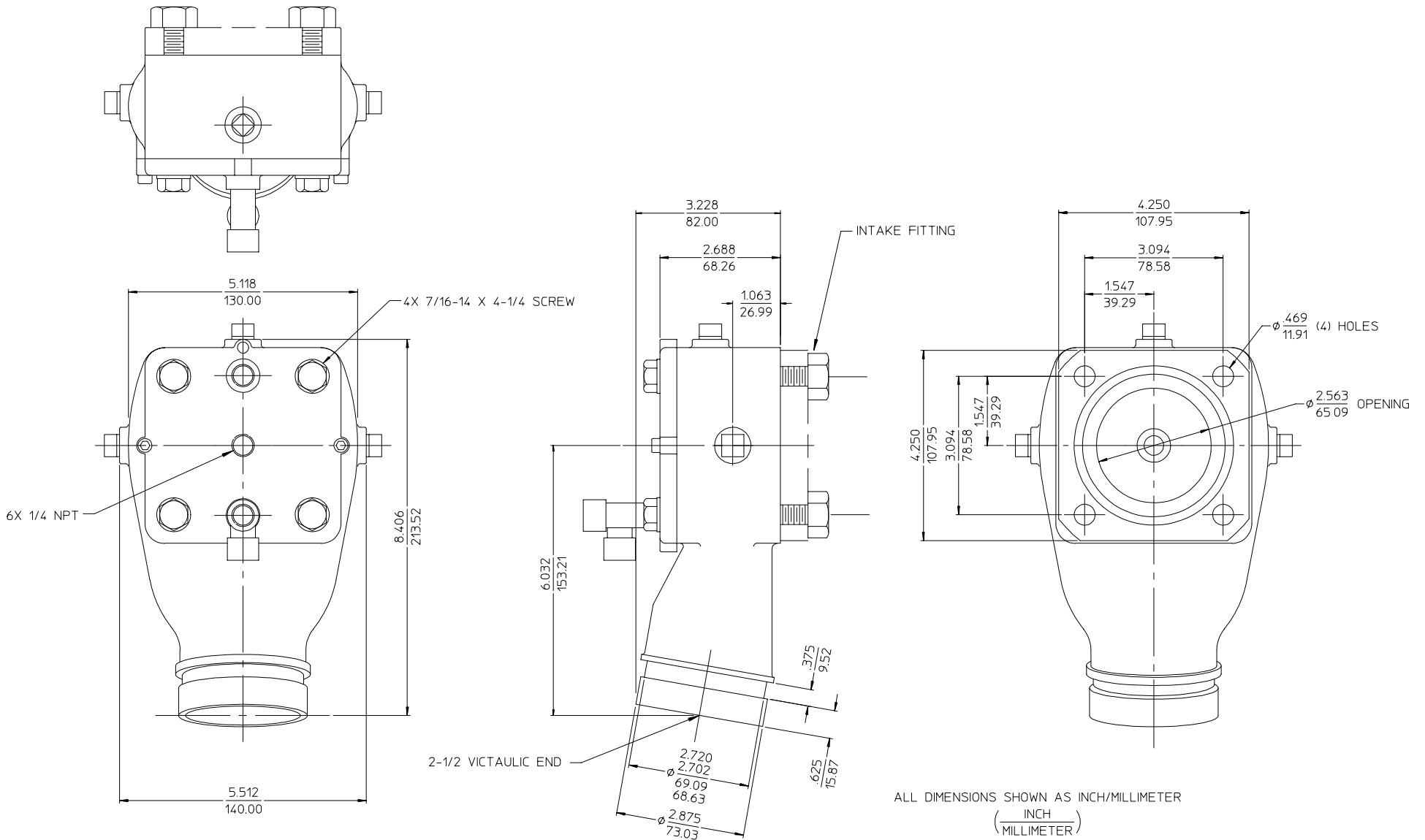

NOTES:  
1. SEE PAGE 1 FOR PILOT VALVE ASSEMBLY DETAILS.

**PUMP MOUNTED RELIEF VALVE WITHOUT EXTENSION**  
(NORMALLY MOUNTED ON INTAKE NIPPLE IN FRONT OF BUTTERFLY VALVE)

INTAKE RELIEF VALVE  
DPL82084-5  
WATEROUS COMPANY  
SOUTH ST. PAUL, MN 55075  
REL: 8/96 PAGE 3 OF 4 REV: 07/11/06

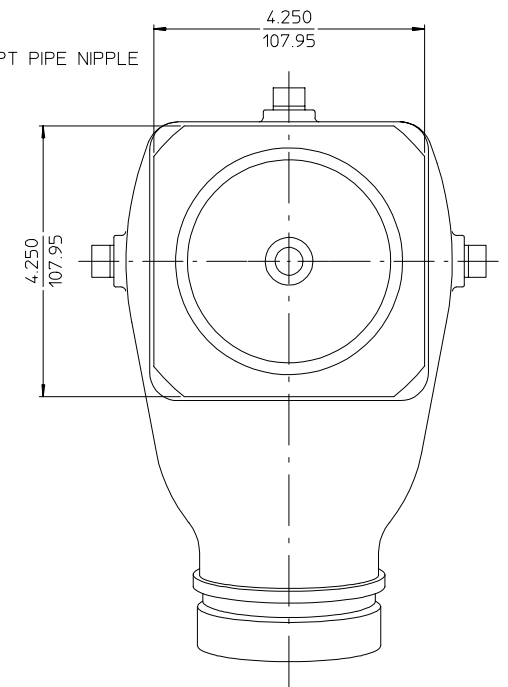
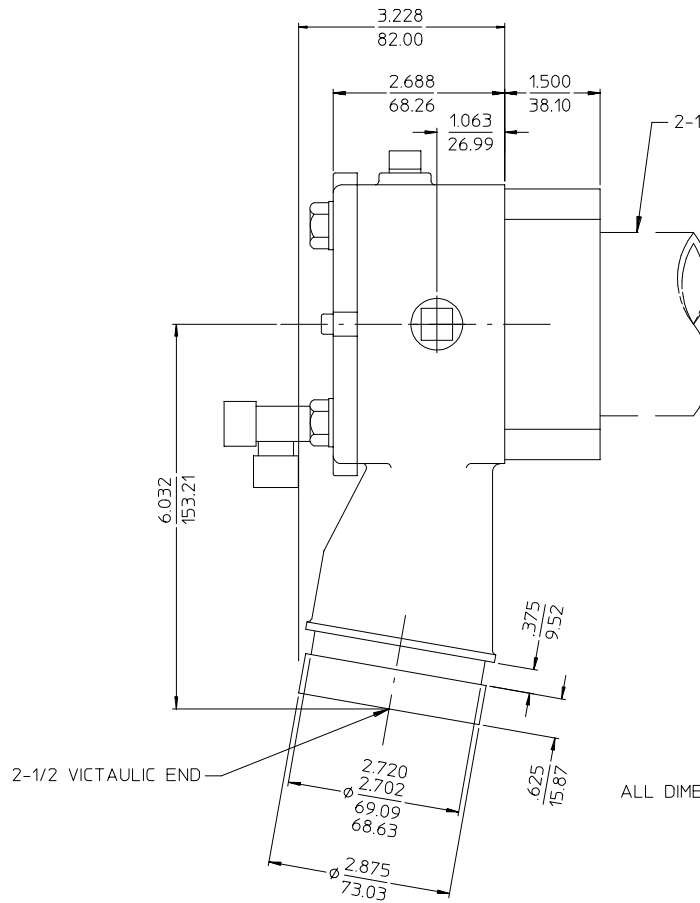
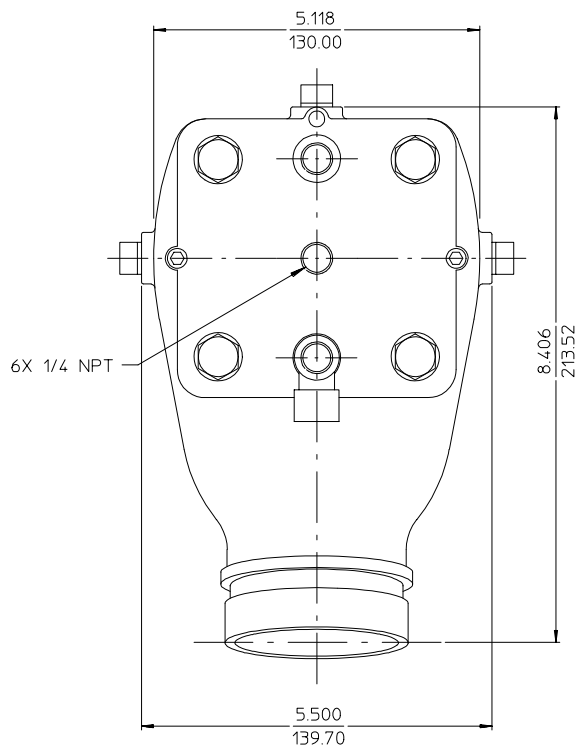
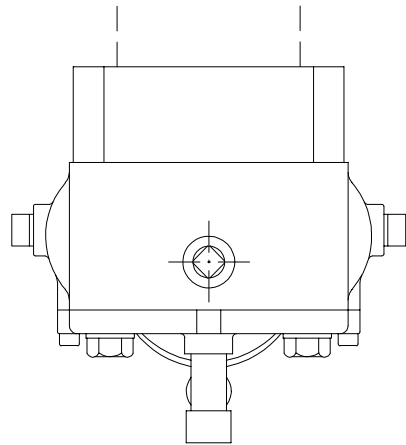

ALL DIMENSIONS SHOWN AS INCH/MILLIMETER

( INCH )  
( MILLIMETER )

**INTAKE RELIEF VALVE**  
**DPL82084-5**  
**WATEROUS COMPANY**  
**SOUTH ST. PAUL, MN 55075**

REL: 8/96 PAGE 4 OF 4 REV: 07/11/06

NOTES:  
 1. SEE PAGE 1 FOR PILOT VALVE ASSEMBLY DETAILS.

**SEPARATELY MOUNTED RELIEF VALVE**