

Dimensional Drawings for Pneumatic Pump and P.T.O. Shift Assemblies

Index:

Components		See Page	
Mounting on Transmission		2	
Panel Plates	In-Cab Panel	3	
	Operator's Panel	Dual Light	4
		Single Light	
Wiring Schematic	Single Light Operator's Panel	5	
	Dual Light Operator's Panel	6	

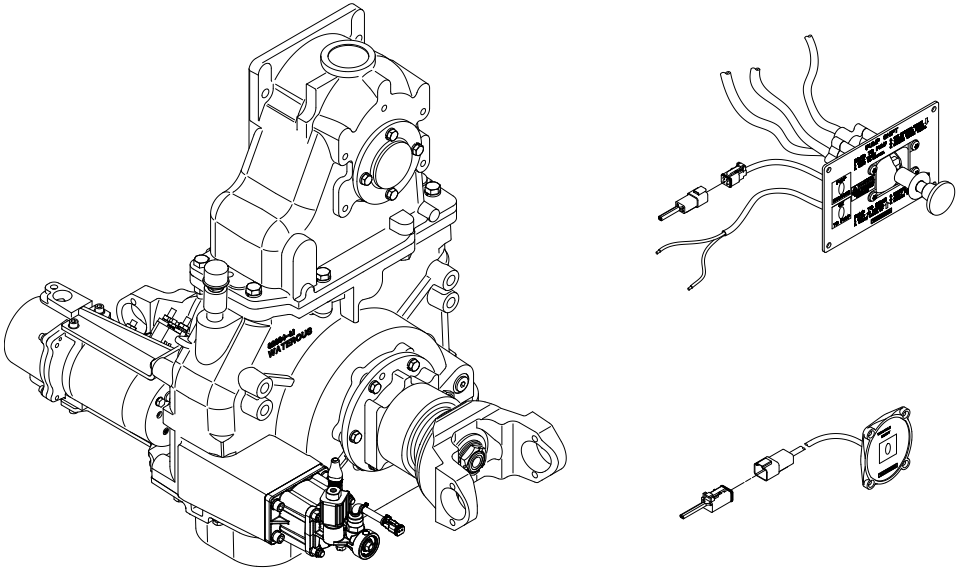

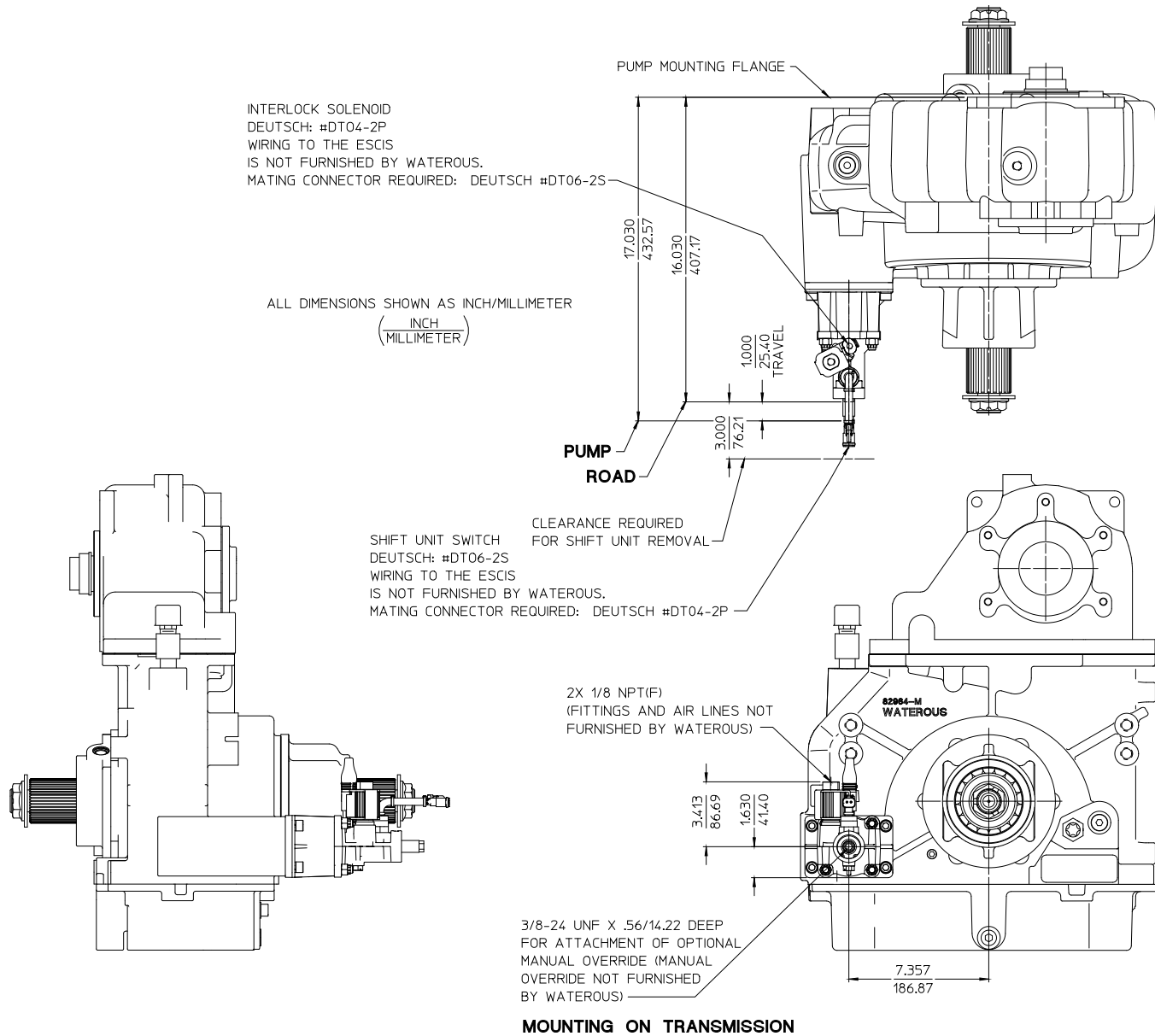

WIRING TO "PUMP ENGAGED" AND "OK TO PUMP" SWITCH(ES) ARE NOT PROVIDED BY WATEROUS. MATING CONNECTOR REQUIRED: DEUTSCH #DT04-4P EACH LED DRAWS 20mA, SIZE WIRE ACCORDINGLY.

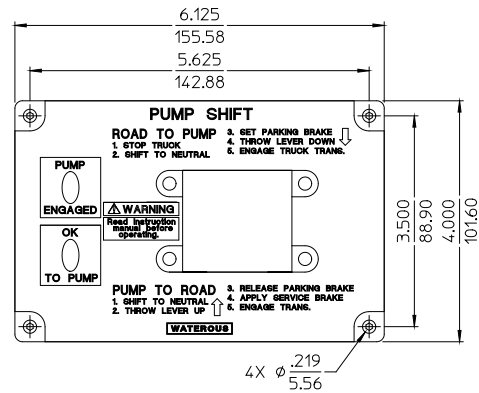
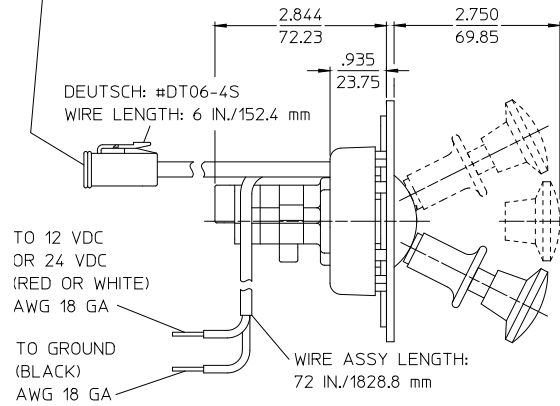

ALL DIMENSIONS SHOWN AS INCH/MILLIMETER

(INCH / MILLIMETER)

IN-CAB PANEL PLATE

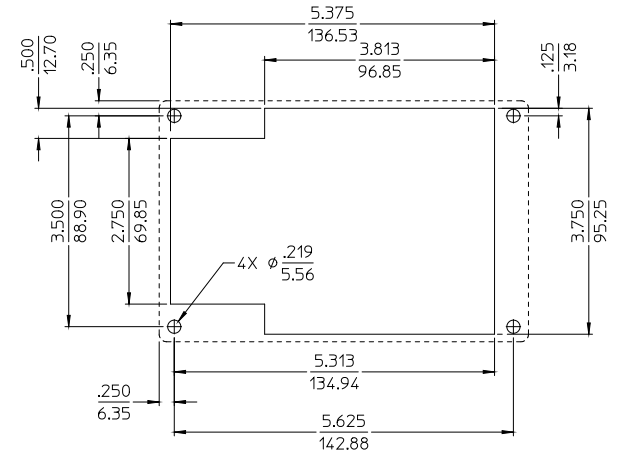

PANEL PLATE HOLE LAYOUT

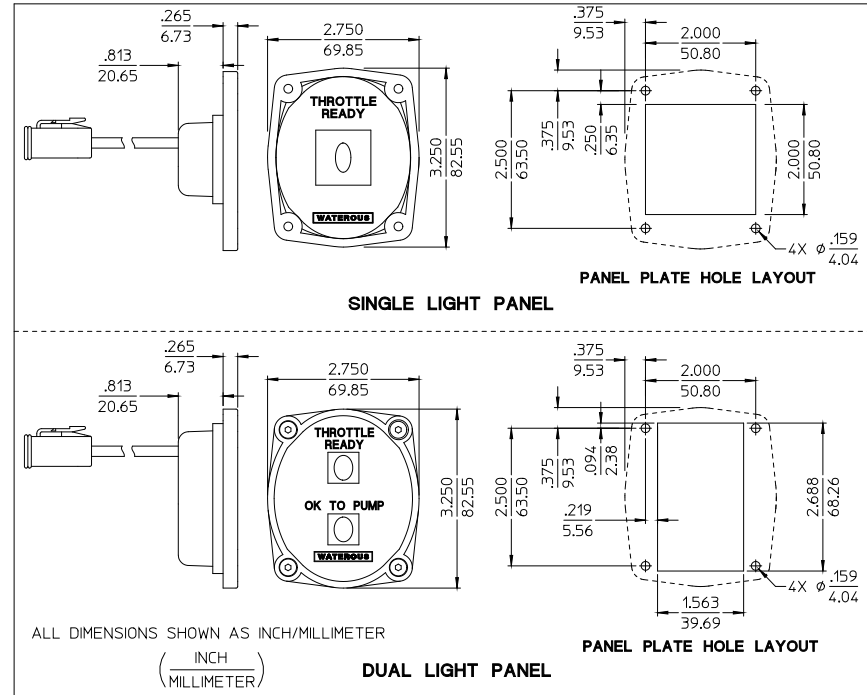
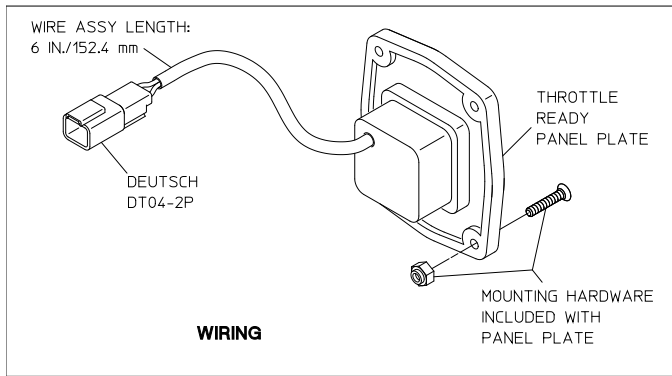

OPERATORS PANEL PLATE

ALL DIMENSIONS SHOWN AS INCH/MILLIMETER
(INCH / MILLIMETER)

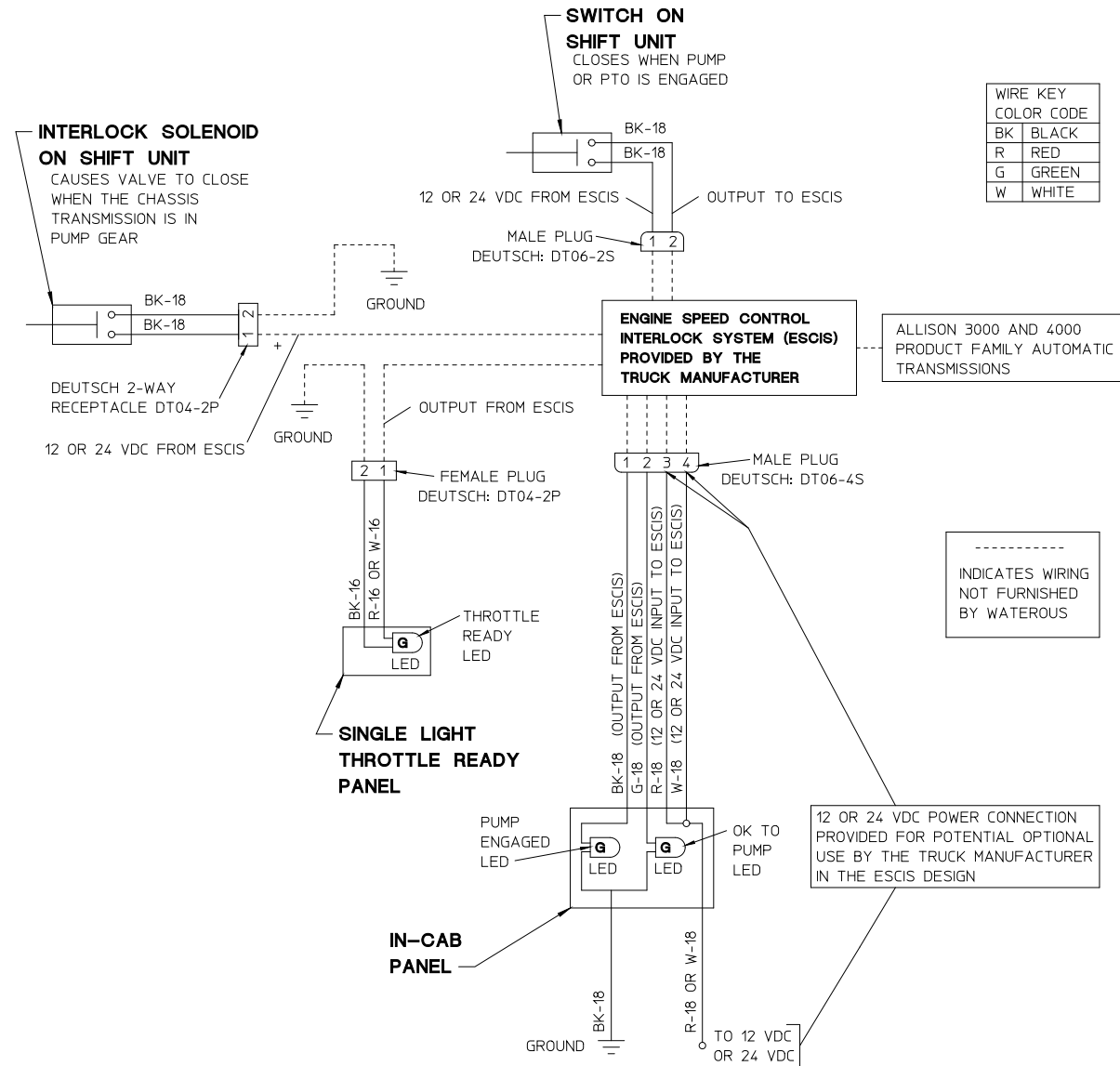

NOTE:
1. NUMBER FOLLOWING COLOR CODE IS THE WIRE SIZE (AWG).
(I.E. BK-16 IS A BLACK 16 AWG WIRE)

WIRING SCHEMATIC—SINGLE LIGHT OPERATORS PANEL

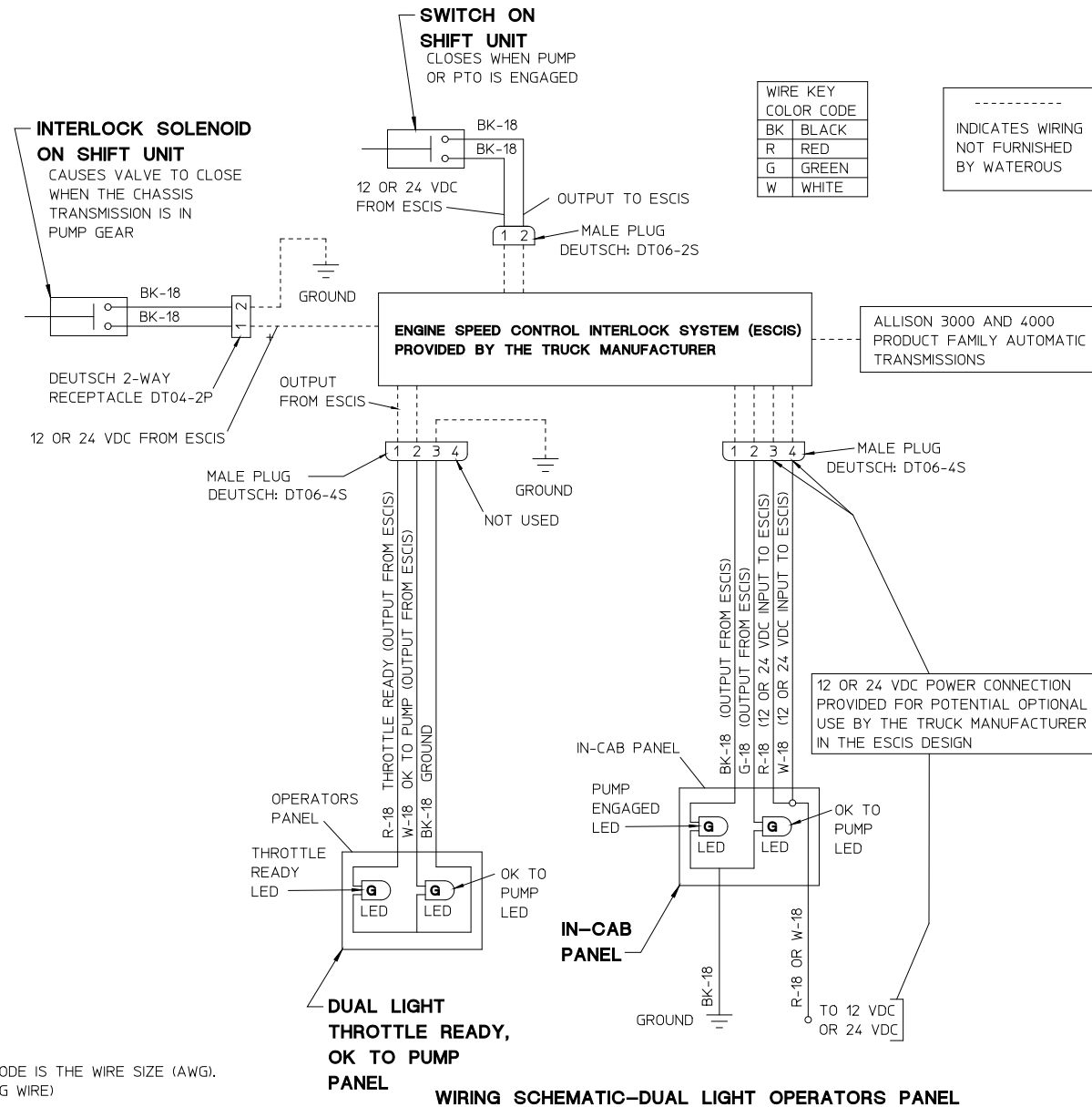

NOTE:
1. NUMBER FOLLOWING COLOR CODE IS THE WIRE SIZE (AWG).
(I.E. BK-16 IS A BLACK 16 AWG WIRE)