



Document Number	Issue Date	Rev. Date
<b>DPL 82343</b>	<b>11/05/97</b>	<b>10/28/09</b>

## Bronze CM Series Fire Pump Dimensional Drawings CM/CPK Combination Pumps with PA Series Transmission

<b>Pump and Transmission</b>							
Pump Type	Transmission		Pump Model		Assembly Number	Input Rotation (1)	See Page
	Model	Drive	Main CM Pump	Secondary CPK Pump			
Two Stage Series/Parallel with CPK Stage	PA Series	PTO Driven, Chain Drive	CMPA	CPK-2	82343	CW	2
			CMUPA	CPK-2	82343-1	CW	3

**Notes:**

1. Input rotation is viewed looking directly at the transmission input shaft.

<b>Basic Pump Dimensions</b>		
Pump	Feature	See Page
Main CM Pump	Intake Adapter Flange	4
	Dishcharge Connections	
	Tank to Pump Flange Options	5
Secondary CPK Pump		6

TABLE 1 - AVAILABLE AS FOLLOWS

MODEL	RATIO	DIMENSION A	DIMENSION B	DIMENSION C	DRIVELINE	
					SIZE	SPLINE
PA	1.71	11.145/283.09	8.169/207.49	11.364/288.65	1-1/2 INCH	1-1/2-10 SAE
	1.91	11.217/284.92	8.097/205.66	11.438/290.53		
	2.05	10.941/277.91	8.373/212.67	11.142/283.01		
CPK-2	1.62					
	1.97					
	2.55					
	3.40					

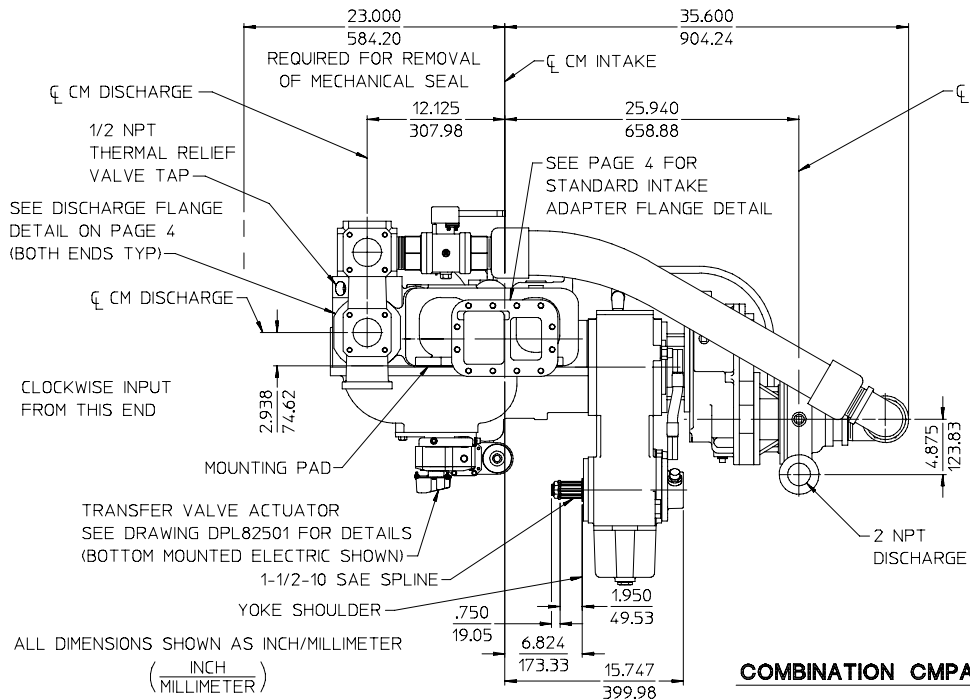

COMBINATION CMPA/CPK-2, ASS'Y NO. 82343

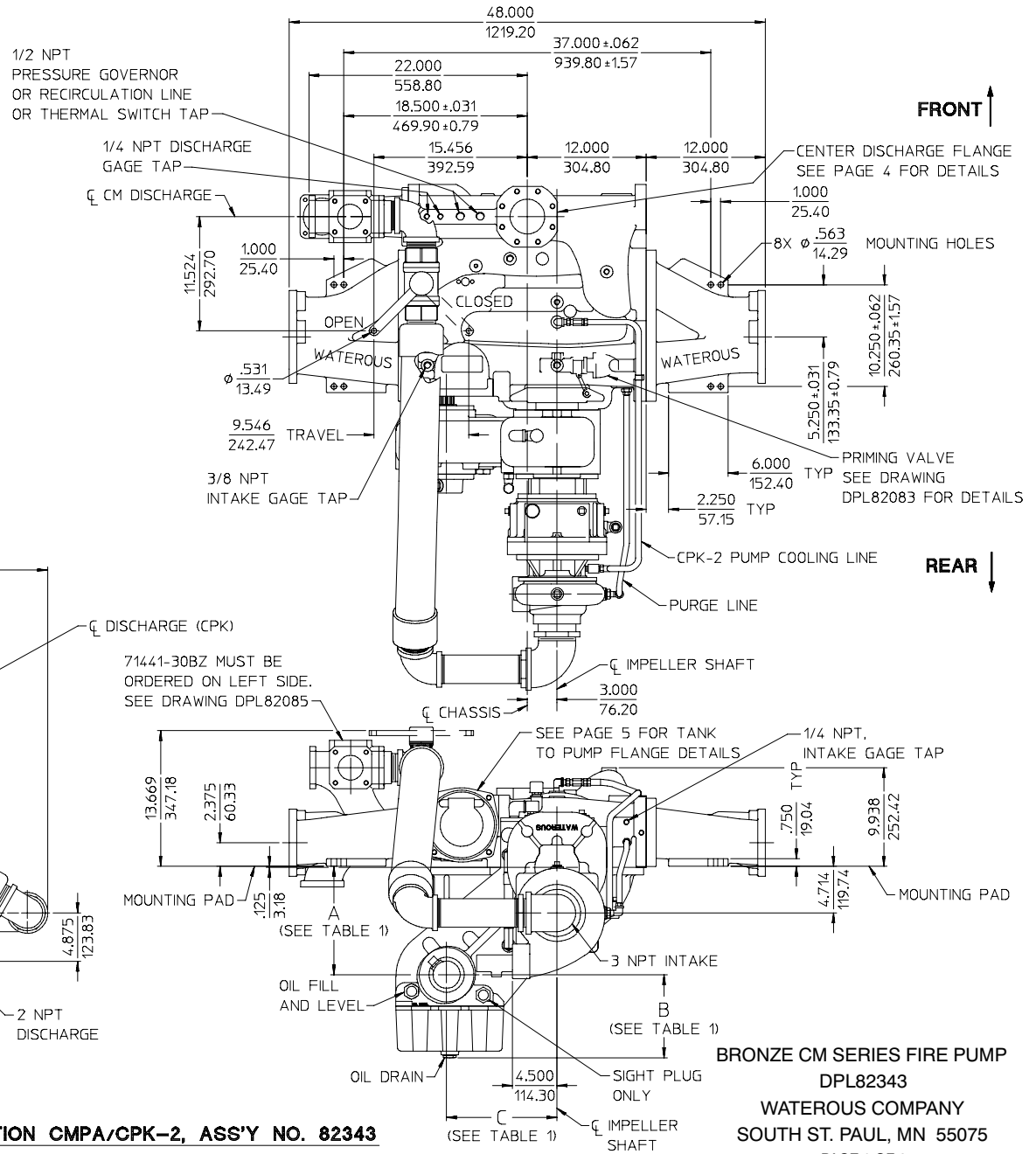

FRONT ↑

REAR ↓

TABLE 1 - AVAILABLE AS FOLLOWS						
MODEL	RATIO	DIMENSION A	DIMENSION B	DIMENSION C	DRIVELINE	
					SIZE	SPLINE
PA	1.71	11.145/283.09	8.169/207.49	11.364/288.65	1-1/2 INCH	1-1/2-10 SAE
	1.91	11.217/284.92	8.097/205.66	11.438/290.53		
	2.05	10.941/277.91	8.373/212.67	11.142/283.01		
CPK-2	1.62					
	1.97					
	2.55					
	3.40					

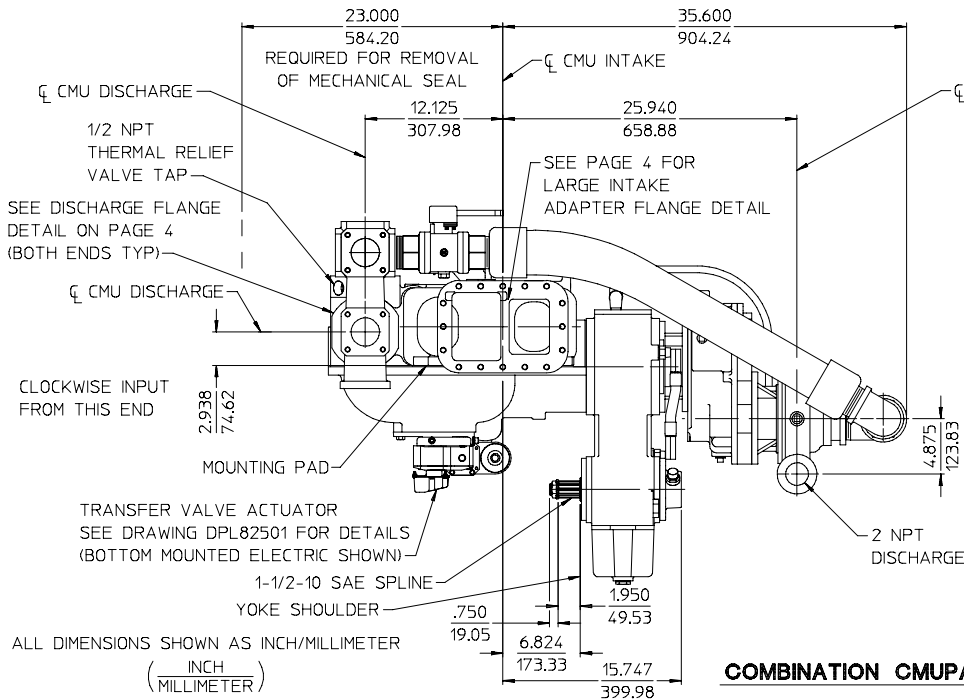

**COMBINATION CMUPA/CPK-2, ASS'Y NO. 82343-1**

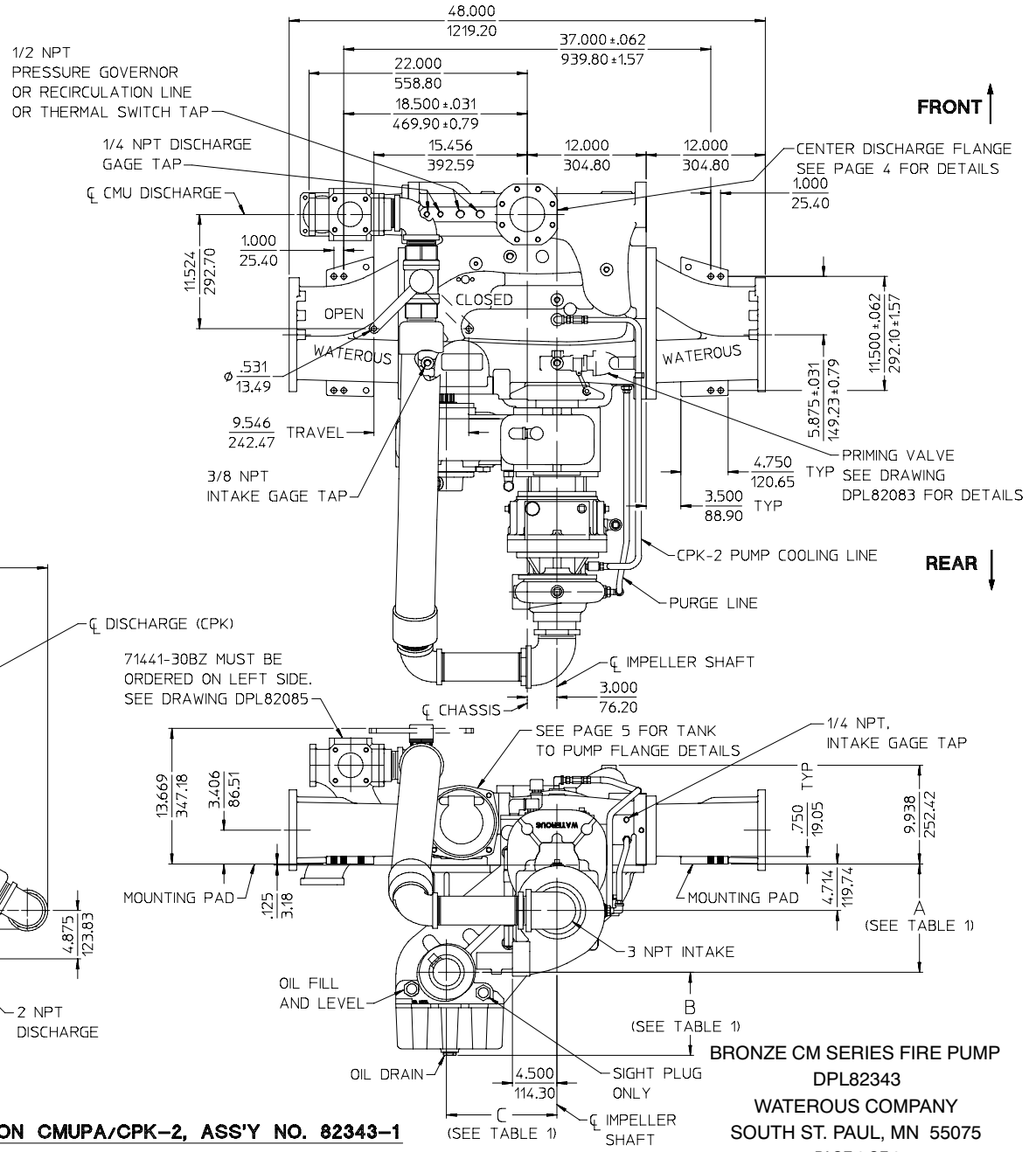

**BRONZE CM SERIES FIRE PUMP**  
**DPL82343**  
**WATEROUS COMPANY**  
**SOUTH ST. PAUL, MN 55075**  
 PAGE 3 OF 6

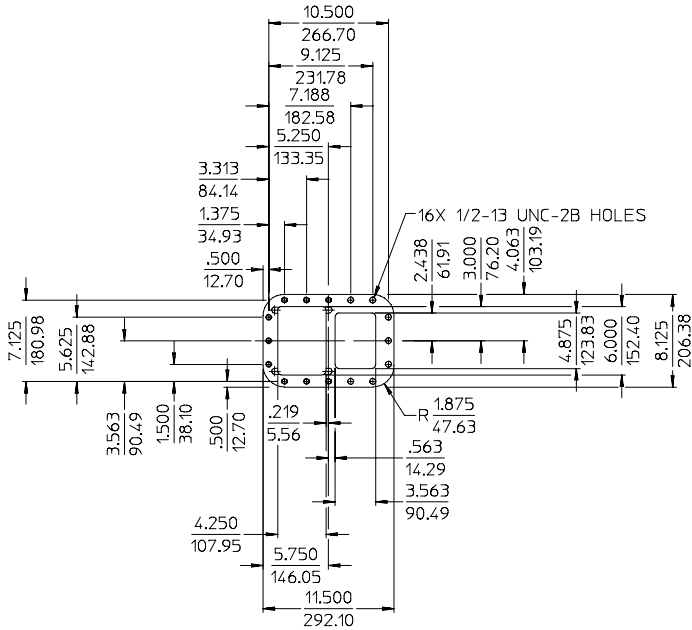

LARGE INTAKE ADAPTER FLANGE DETAIL  
SPECIFY INTAKE FITTINGS FROM SECTION 2 OF DRAWING DPL81867

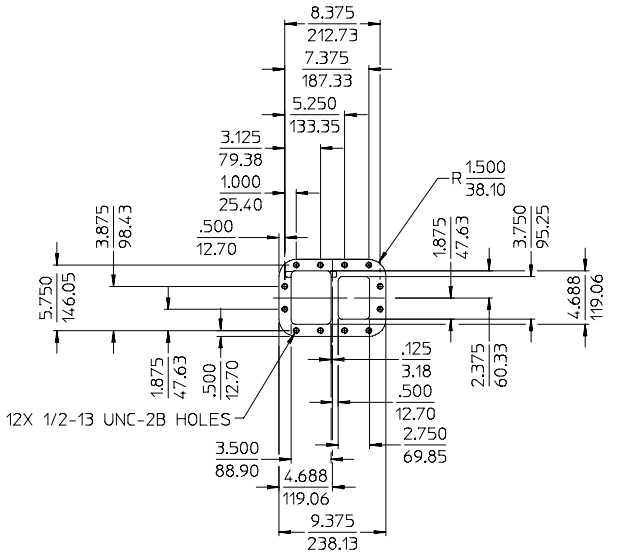

STANDARD INTAKE ADAPTER FLANGE DETAIL  
SPECIFY INTAKE FITTINGS FROM SECTION 1 OF DRAWING DPL81867

**INTAKE ADAPTER FLANGE**

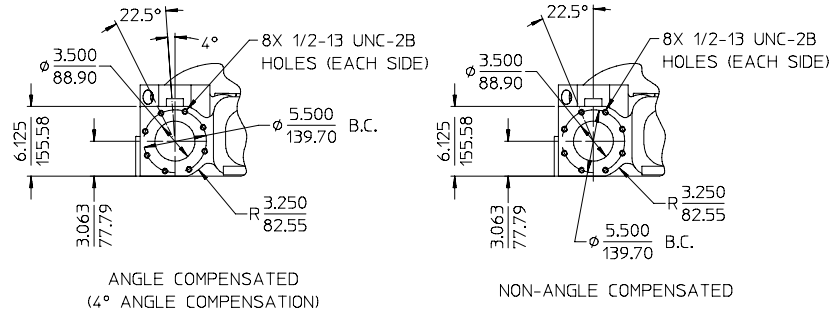

DISCHARGE FLANGE CONFIGURATIONS  
SEE DRAWING DPL82085 FOR INFORMATION  
ON ORDERING DISCHARGES FITTING AND VALVES

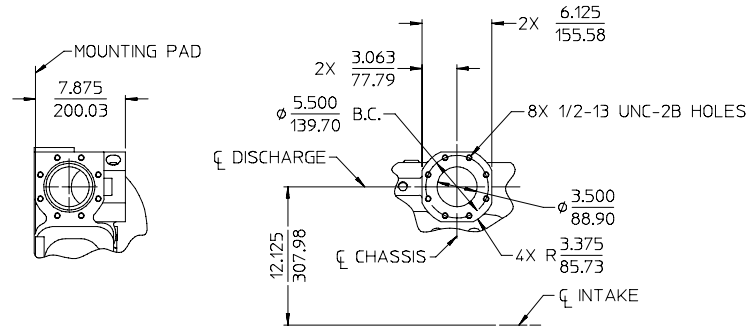

CENTER DISCHARGE FLANGE  
SEE DRAWING DPL82089 FOR INFORMATION ON ORDERING DISCHARGE FITTINGS  
OR SEE WATEROUS "CENTER DISCHARGE PIPING MANUAL" FOR AVAILABLE  
EXISTING ARRANGEMENTS

**DISCHARGE CONNECTIONS**

ALL DIMENSIONS SHOWN AS INCH/MILLIMETER  
( $\frac{\text{INCH}}{\text{MILLIMETER}}$ )

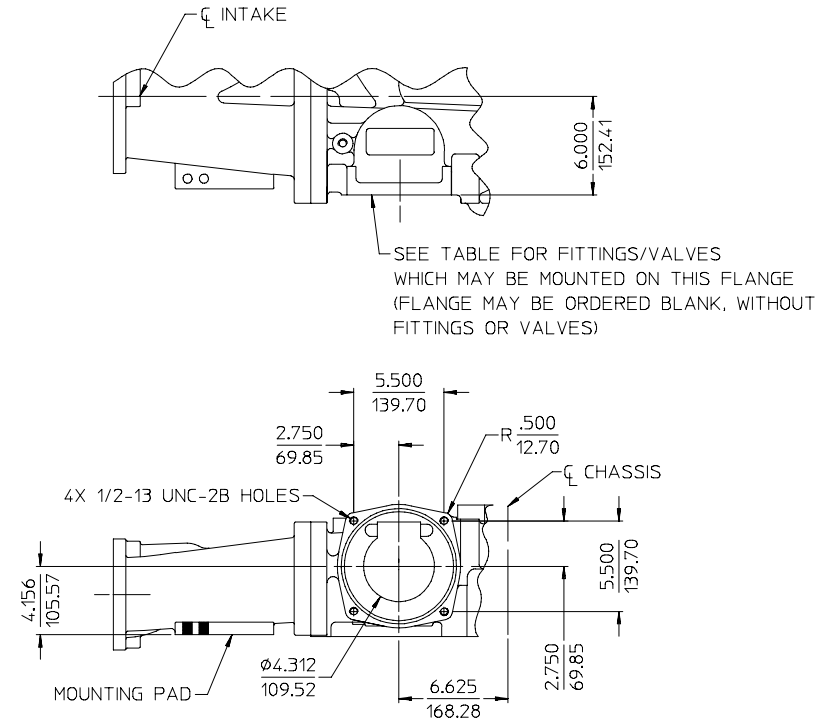
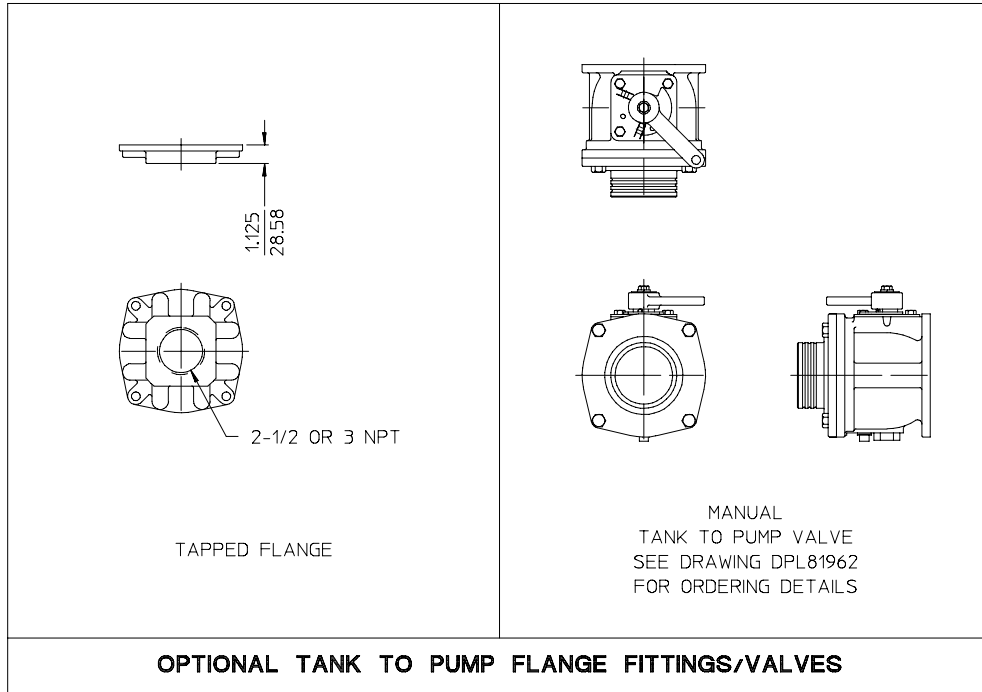

**TANK TO PUMP FLANGE**

(USE O-RING W37108-4)  
(AVAILABLE WITH OR WITHOUT CHECK VALVE)

ALL DIMENSIONS SHOWN AS INCH/MILLIMETER  
( $\frac{\text{INCH}}{\text{MILLIMETER}}$ )

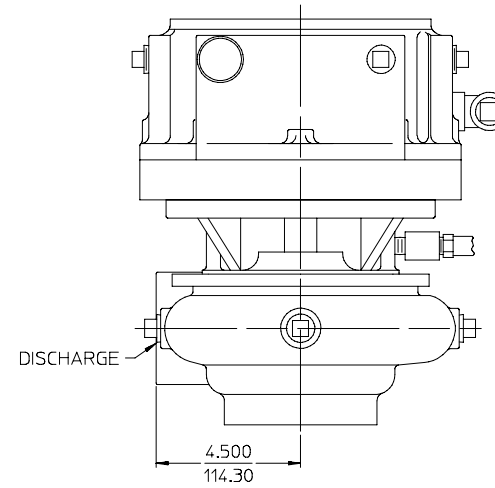

ORDERING INFORMATION

CMPA/CPK-2  
CMUPA/CPK-2

SPECIFY CMPA/CMUPA PUMP AND CPK-2 PUMP SEPARATELY

CMPA/CMUPA PUMP - MODEL: CMPA OR CMUPA

RATIO: SEE TABLE 1 ON PAGE 2 OR 3

CPK PUMP - MODEL: CPK-2

RATIO: SEE TABLE 1 ON PAGE 2 OR 3

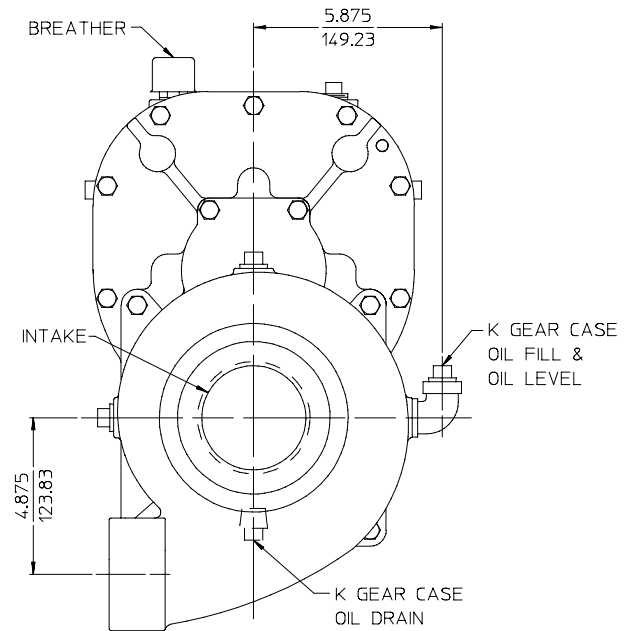

**CMPA/CPK-2**  
**CMUPA/CPK-2**  
INVERTED TRANSMISSION MOUNTING  
DISCHARGE FIGURE 2

**BRONZE CM SERIES FIRE PUMP**  
**DPL82343**

**WATEROUS COMPANY**  
**SOUTH ST. PAUL, MN 55075**

PAGE 6 OF 6

ALL DIMENSIONS SHOWN AS INCH/MILLIMETER

( $\frac{\text{INCH}}{\text{MILLIMETER}}$ )

**CPK-2 PUMP CONFIGURATION**