



Document Number DPL83000	Issue Date 04/01/09	Rev. Date 10/28/19
------------------------------------	-------------------------------	------------------------------

Dimensional Drawings for TC20 Series P.T.O.

Item	See Page
TC20 Models	2, 3
Ratio and Drop Dimensions	4
Output Options	5
Optional End Yokes and Companion Flanges	6
Electronic Tachometer Connection	
Mounting Bracket Attachment Locations	7

TABLE 1 - AVAILABLE DRIVELINE / MODELS								
DRIVELINE			OPTIONAL END YOKES AND COMPANION FLANGES AVAILABLE FROM WATEROUS. SEE DETAIL D ON PAGE 6				MODEL	
TYPE	SIZE	SPLINE	YOKE		CROSS AND BEARING KIT	COMPANION FLANGE		
EXTRA HEAVY DUTY	2.35 INCH	2.350-46T INVOLUTE	SPICER SERIES	PART NUMBER	V 2839	1480/1610	V 3719	TC20B, TC20C, TC20D, TC20E, TC20F
			1710 BP	V 2837				
			1810 BP	V 2838	V 2840	1650/1710	V 3619	
			1710 HR	V 4101	--			
			1810 HR	V 4102	--			
SPL140	V 3388	V 3389	--	--				

NOTE:
1. SEE TABLE 2 ON PAGE 4 FOR AVAILABLE RATIOS.

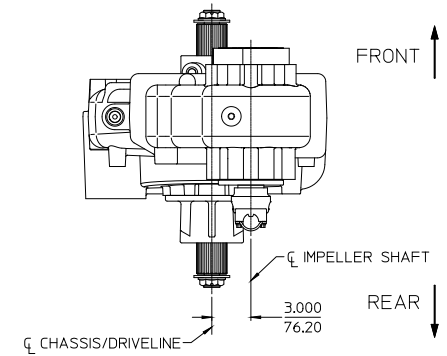
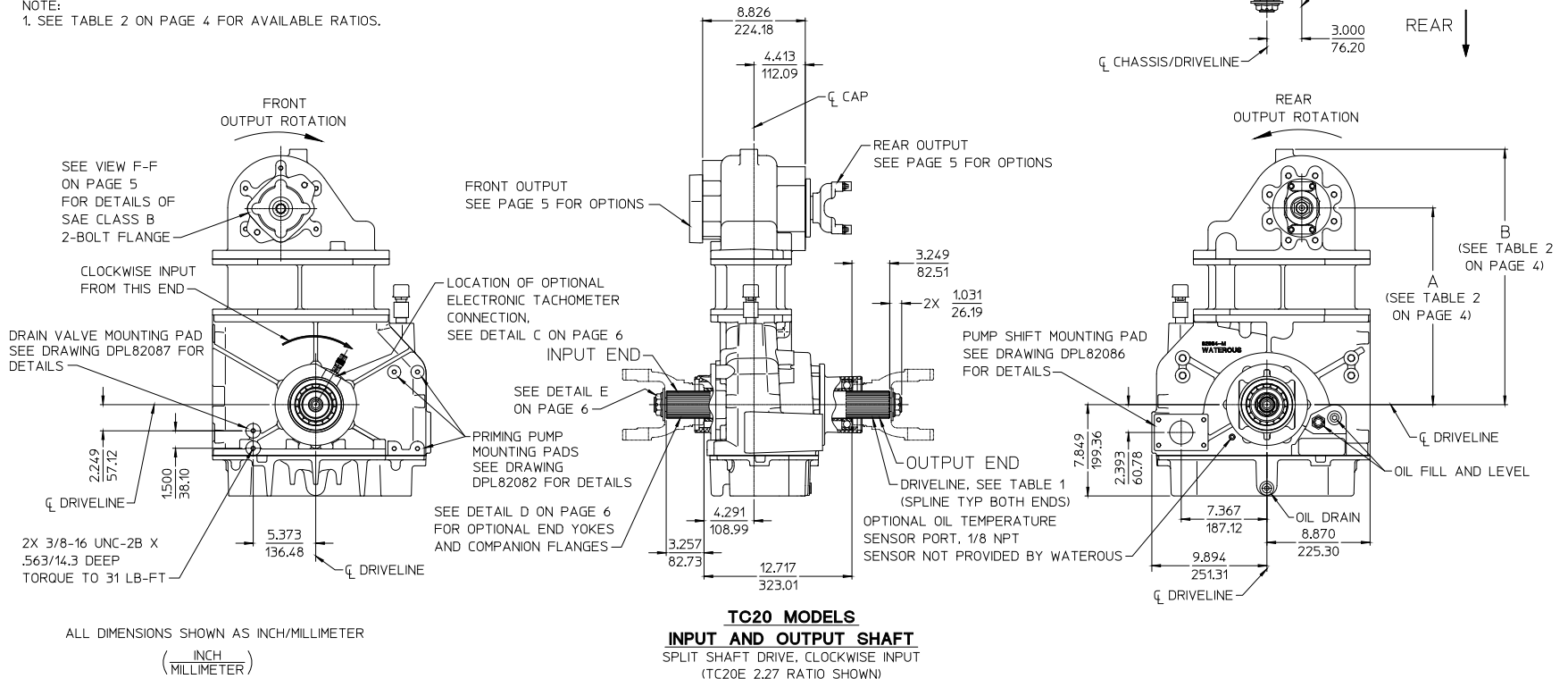
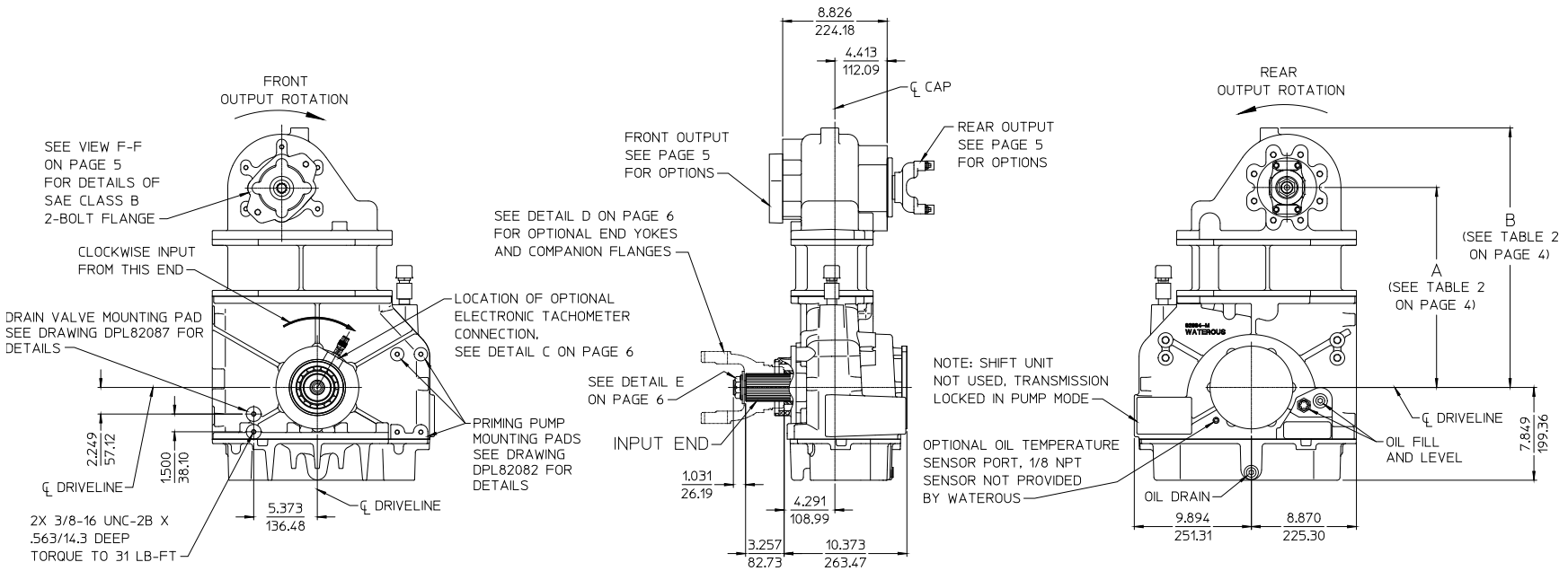
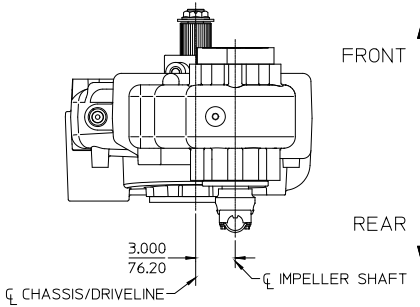

TABLE 1 - AVAILABLE DRIVELINE / MODELS							
DRIVELINE			OPTIONAL END YOKES AND COMPANION FLANGE AVAILABLE FROM WATEROUS, SEE DETAIL D ON PAGE 6				MODEL
TYPE	SIZE	SPLINE	YOKE		CROSS AND BEARING KIT	COMPANION FLANGE	
EXTRA HEAVY DUTY	2.35 INCH	2.350-46T INVOLUTE	SPICER SERIES	PART NUMBER	V 2839	SPICER SERIES	PART NUMBER
			1710 BP	V 2837		1480/1610	V 3719
			1810 BP	V 2838		1650/1710	V 3619
			1710 HR	V 4101		--	--
			1810 HR	V 4102		--	--
SPL140	V 3388	V 3389	--	--	TC20B, TC20C, TC20D, TC20E, TC20F		

NOTE:
1. SEE TABLE 2 ON PAGE 4 FOR AVAILABLE RATIOS.



ALL DIMENSIONS SHOWN AS INCH/MILLIMETER
($\frac{\text{INCH}}{\text{MILLIMETER}}$)

TC20 MODELS
INPUT SHAFT ONLY
SPLIT SHAFT DRIVE, CLOCKWISE INPUT
(TC20E 2.27 RATIO SHOWN)

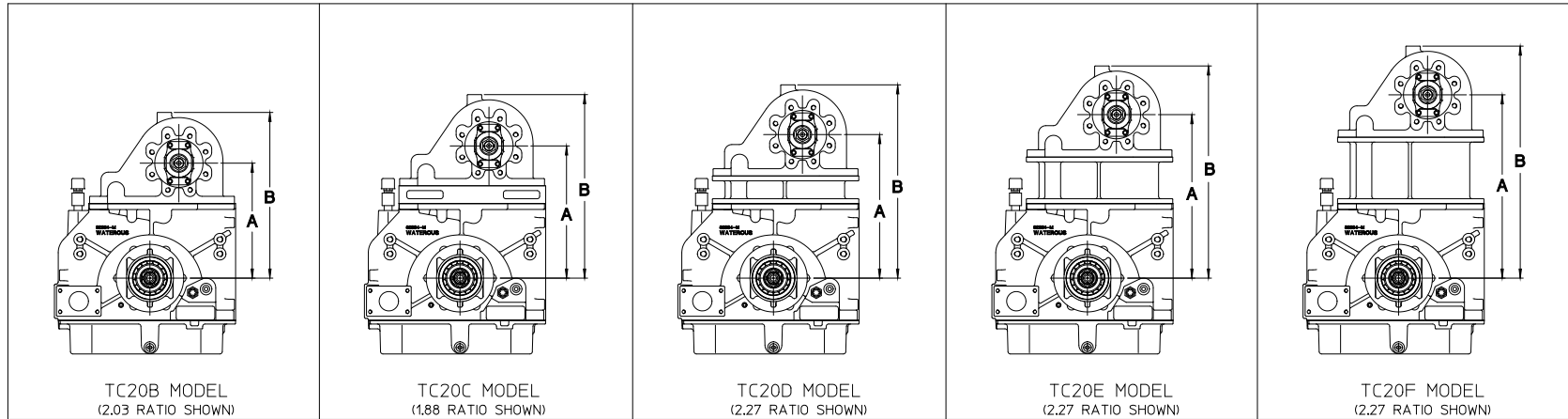

TABLE 2 - AVAILABLE RATIOS

DRIVE TO DRIVEN RATIO	TC20B		TC20C		TC20D		TC20E		TC20F	
	DIMENSION A	DIMENSION B	DIMENSION A	DIMENSION B	DIMENSION A	DIMENSION B	DIMENSION A	DIMENSION B	DIMENSION A	DIMENSION B
1.14	11.875/301.63	17.184/436.47	13.929/353.80	19.079/484.61	14.959/379.96	20.109/510.77	16.995/431.67	22.035/559.69	19.027/483.29	24.067/611.30
1.27	12.250/311.15	17.194/436.73	14.312/363.52	19.256/489.10	14.825/376.56	20.078/509.98	16.861/428.27	22.011/559.08	18.892/479.86	24.042/610.67
1.41	11.840/300.74	17.149/435.58	13.899/353.03	19.049/483.84	14.931/379.25	20.081/510.06	16.971/431.06	22.011/559.08	19.002/482.65	24.042/610.67
1.48	12.326/313.08	17.270/438.66	13.878/352.50	19.131/485.93	14.907/378.64	20.057/509.45	16.951/430.56	21.991/558.57	18.981/482.12	24.021/610.13
1.58	12.205/310.01	17.149/435.58	13.756/349.40	19.009/482.83	14.788/375.62	20.041/509.04	16.830/427.48	21.980/558.29	18.861/479.07	24.011/609.88
1.69	12.290/312.17	17.234/437.74	13.839/351.51	18.989/482.32	14.876/377.85	20.026/508.66	16.923/429.84	22.073/560.65	18.961/481.61	24.111/612.42
1.79	11.958/303.73	17.211/437.16	14.045/356.74	18.989/482.32	15.072/382.83	20.016/508.41	17.127/435.03	22.071/560.60	19.168/486.87	24.112/612.44
1.88	12.129/308.08	17.169/436.09	13.690/347.73	18.999/482.57	14.717/373.81	20.026/508.66	16.773/426.03	22.026/559.46	18.809/477.75	24.062/611.17
1.97	12.306/312.57	17.250/438.15	13.870/352.30	19.020/483.11	14.912/378.76	20.062/509.57	16.970/431.04	22.010/559.05	19.012/482.90	24.052/610.92
2.03	11.896/302.16	17.149/435.58	13.984/355.19	19.024/483.21	15.028/381.71	20.068/509.73	17.086/433.98	22.030/559.56	19.132/485.95	24.076/611.53
2.27	12.240/310.90	17.184/436.47	13.811/350.80	19.064/484.23	14.856/377.34	20.006/508.15	16.920/429.77	21.960/557.78	18.971/481.86	24.011/609.88
2.46	11.941/303.30	17.194/436.73	14.036/356.51	19.082/484.68	15.087/383.21	20.031/508.79	17.154/435.71	22.098/561.29	19.205/487.81	24.149/613.38
2.68	12.169/309.09	17.209/437.11	13.746/349.15	18.999/482.58	14.793/375.74	20.046/509.17	16.865/428.37	22.015/559.18	18.923/480.64	24.073/611.45

RATIO AND DROP DIMENSIONS

ALL DIMENSIONS SHOWN AS INCH/MILLIMETER

(INCH
MILLIMETER)

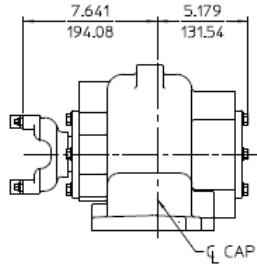

FRONT FACING 1410 SERIES END YOKE (SINGLE)

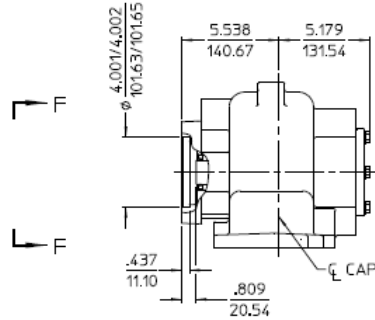

FRONT FACING SAE CLASS B, 2-BOLT (SINGLE)

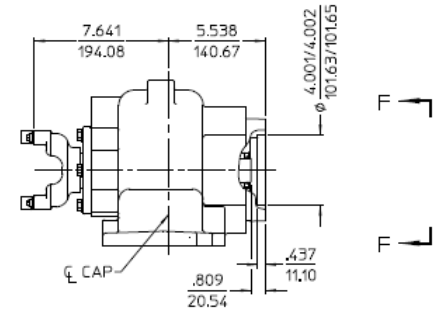

FRONT FACING 1410 SERIES END YOKE WITH REAR FACING SAE CLASS B, 2-BOLT (DUAL)

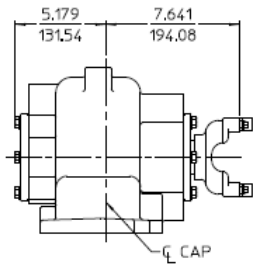

REAR FACING 1410 SERIES END YOKE (SINGLE)

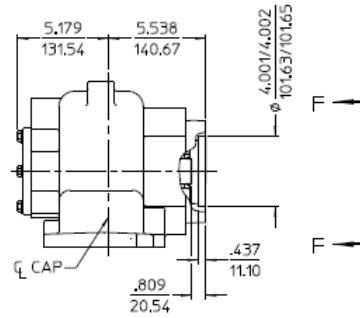

REAR FACING SAE CLASS B, 2-BOLT (SINGLE)

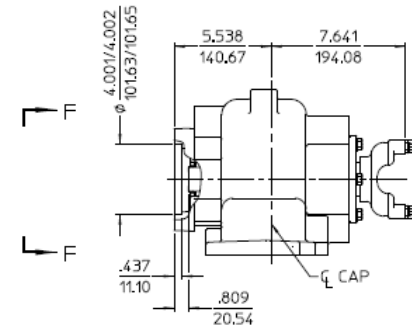

FRONT FACING SAE CLASS B, 2-BOLT WITH REAR FACING 1410 SERIES END YOKE (DUAL)

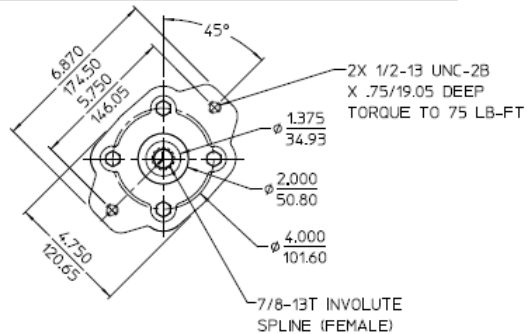

VIEW F-F
HYDRAULIC PUMP ADAPTER FLANGE
USED FOR SAE J744 CLASS B 2-BOLT
HYDRAULIC PUMP WITH MALE
7/8-13T 16/32 PITCH INVOLUTE SPLINE

OUTPUT OPTIONS

ALL DIMENSIONS SHOWN AS INCH/MILLIMETER
(INCH / MILLIMETER)

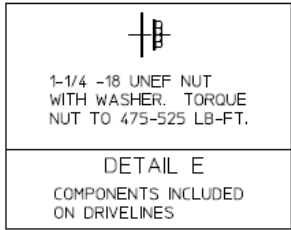
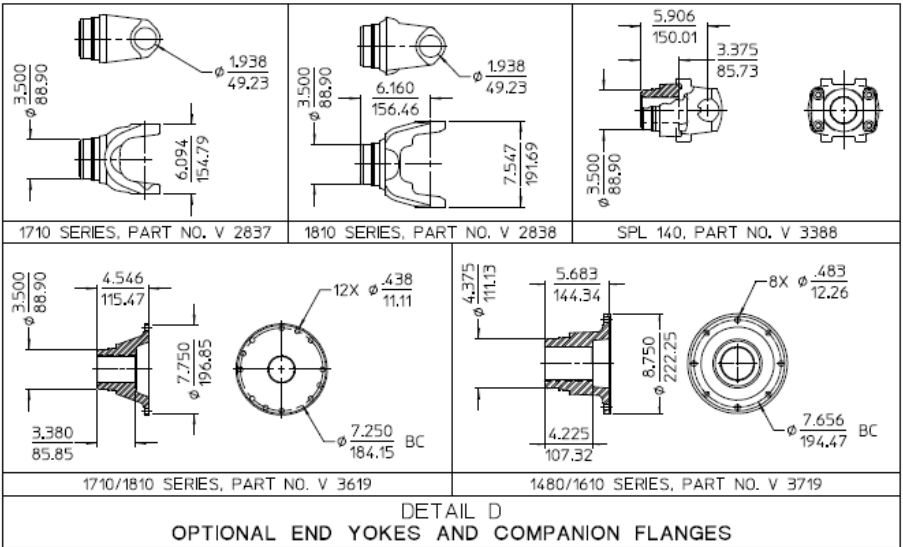
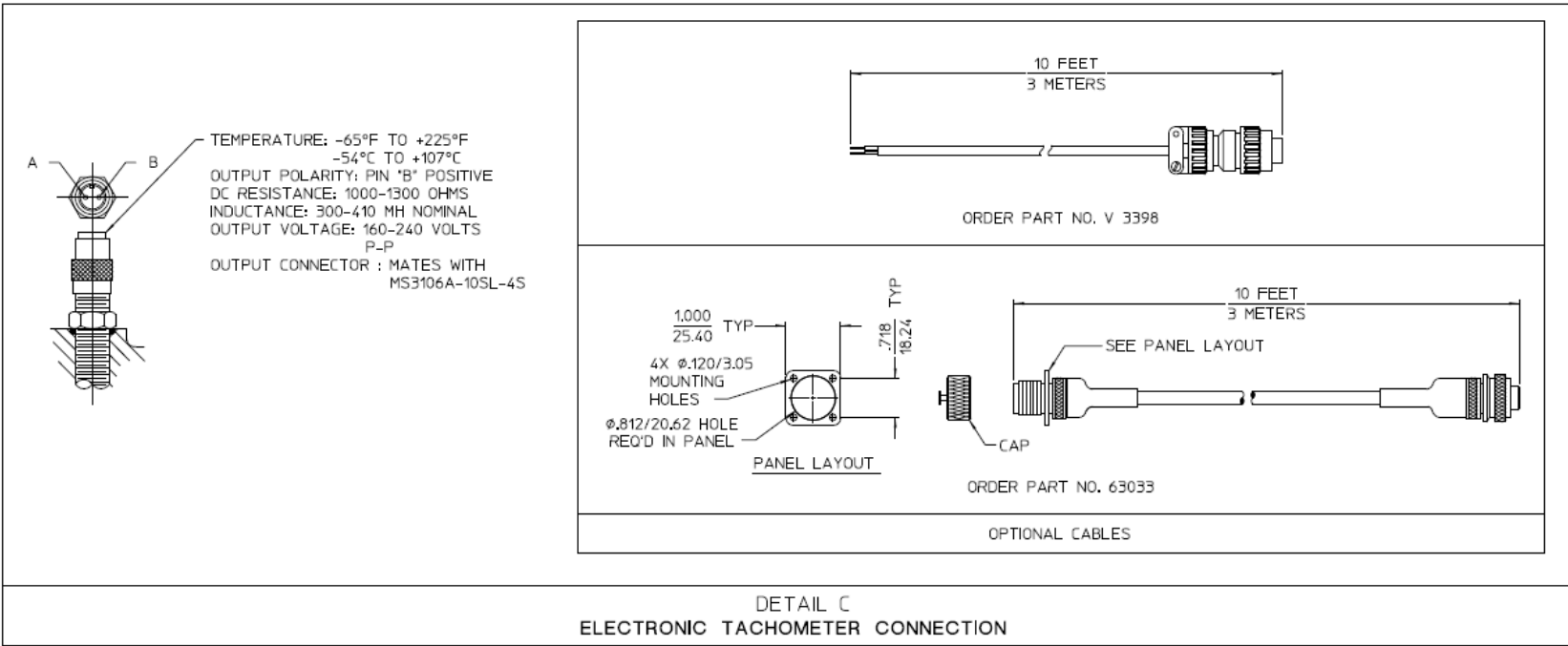

ALL DIMENSIONS SHOWN AS INCH/MILLIMETER
 (INCH)
 (MILLIMETER)

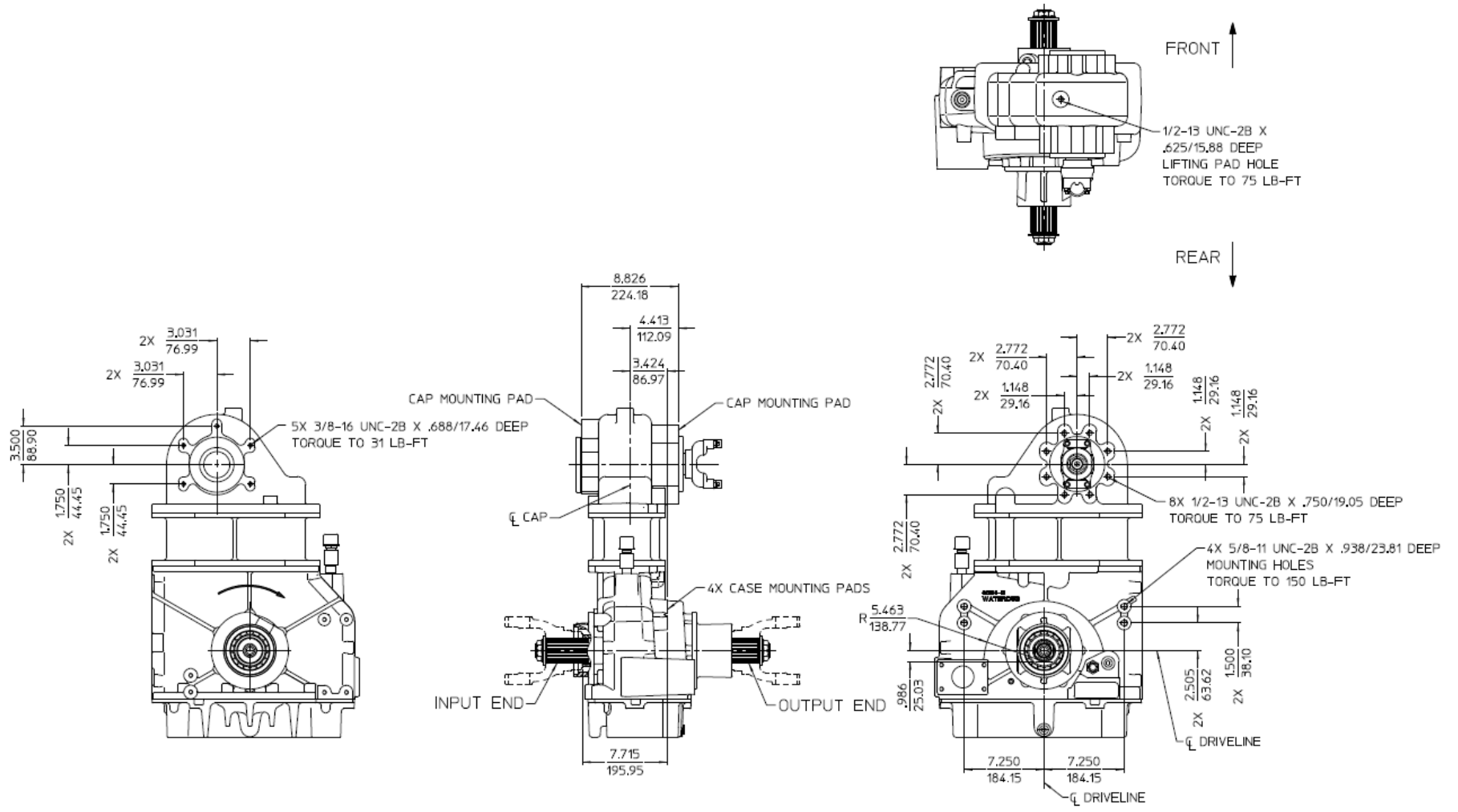

ALL DIMENSIONS SHOWN AS INCH/MILLIMETER
 (INCH / MILLIMETER)

MOUNTING BRACKET ATTACHMENT LOCATIONS