

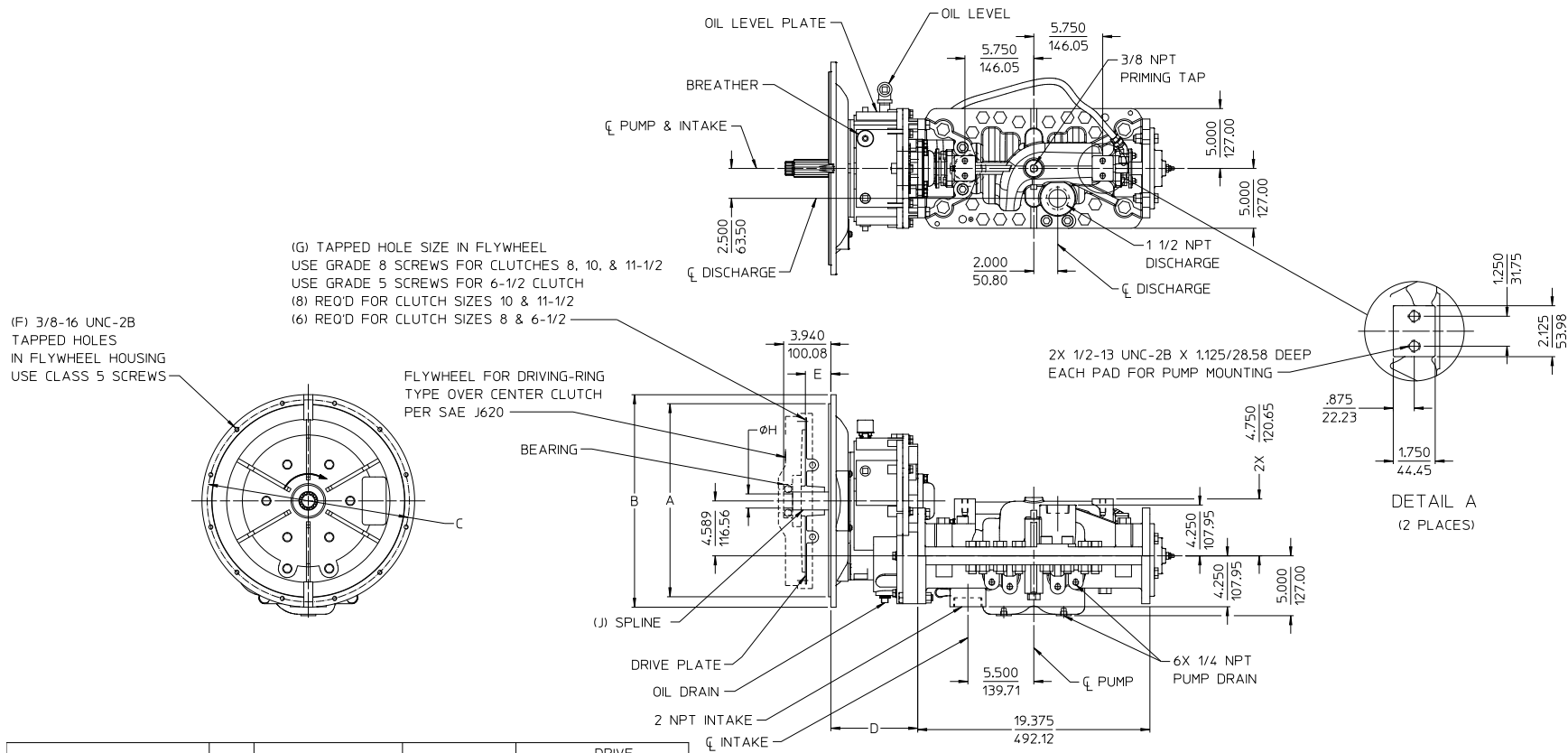

Document Number	Issue Date	Rev. Date
<b>DPL 83149</b>	<b>08/18/10</b>	<b>7/19/18</b>

## Dimensional Drawings for CP-4UH Series Fire Pumps

<b>Index</b>	<b>See Page</b>
Pump with T Series Transmission, Model CPT-4UH	2



(G) TAPPED HOLE SIZE IN FLYWHEEL  
 USE GRADE 8 SCREWS FOR CLUTCHES 8, 10, & 11-1/2  
 USE GRADE 5 SCREWS FOR 6-1/2 CLUTCH  
 (8) REQ'D FOR CLUTCH SIZES 10 & 11-1/2  
 (6) REQ'D FOR CLUTCH SIZES 8 & 6-1/2

(F) 3/8-16 UNC-2B  
 TAPPED HOLES  
 IN FLYWHEEL HOUSING  
 USE CLASS 5 SCREWS

FLYWHEEL FOR DRIVING-RING  
 TYPE OVER CENTER CLUTCH  
 PER SAE J620

DETAIL A  
 (2 PLACES)

SIZE	SAE BELLHOUSING				D	SAE FLYWHEEL			DRIVE PLATE		DRIVE SHAFT	
	A	B	C	F		CLUTCH NUMBER	E	G	PART NUMBER	TORQUE RATING	H	J
3	16.125	17.750	16.875	12	7.250	10	2.12	3/8-16	V2272	850 FT-LB	1.1805/1.1800	1-1/2-10 S.A.E.
	409.58	450.85	428.63									
4	14.250	15.875	15.000	12	7.250	11-1/2	1.56	N/A	V2461	425 FT-LB	1.1805/1.1800	1-1/2-10 S.A.E.
	361.95	403.23	381.00									
3	16.125	17.750	16.875	8	6.250	6-1/2	2.44	5/16-18	V2852	N/A	.7868/.7858	1-15T INVOLUTE
	409.58	450.85	428.63									
4	14.250	15.875	15.000	8	6.250	6-1/2	2.44	5/16-18	V2852	N/A	.7868/.7858	1-15T INVOLUTE
	361.95	403.23	381.00									
5	12.375	14.000	13.125	8	6.250	6-1/2	1.19	5/16-18	V2865	N/A	.7868/.7858	1-15T INVOLUTE
	314.33	355.60	333.38									

ALL DIMENSION SHOWN IN INCH/MILLIMETER

( INCH / MILLIMETER )

**MODEL CPT-4UH**

PUMP AND TRANSMISSION AVAILABLE ONLY AS SHOWN  
 (MDT, CLOCKWISE INPUT ROTATION, INVERTED, TWO GEAR WITHOUT CLUTCH)  
 (VERTICAL PUMP MOUNTING, DISCHARGE UP)