

HL200 and HL300 Series Pump Dimensional Drawings

Pump Model	Drive			Impeller Rotation (2)	See Page										
	Type	Input Shaft	Input Rotation (1)		Pump and Transmission			Available			Optional				
					Pump	Transmission Mounting Positions	Priming Isolation Valve (PIV) Solenoid Valve	Intake Connections	Discharge Manifold	Auxiliary Fittings	RTP Foam System		Control Panels		Gauges and Monitors
Mounted on Pump		Remotely Mounted	Panels	Wiring Schematic											
HL200D HL300D	Direct Drive	1410 Series Companion Flange	CW	CCW	2	--	7	8, 9	10	11, 12	13	See DPL83197	14	15	16
			CCW	CW	3										
HL200K HL300K	Heavy Duty K Series Transmission	1-3/8-10 SAE Spline	CW	CW	4	6									
			CCW	CCW	5	6									

Notes:

1. Drive input rotation defined as viewed looking directly at direct drive or transmission input shaft.
2. Impeller rotation defined as viewed looking directly into impeller eye from intake end of pump.

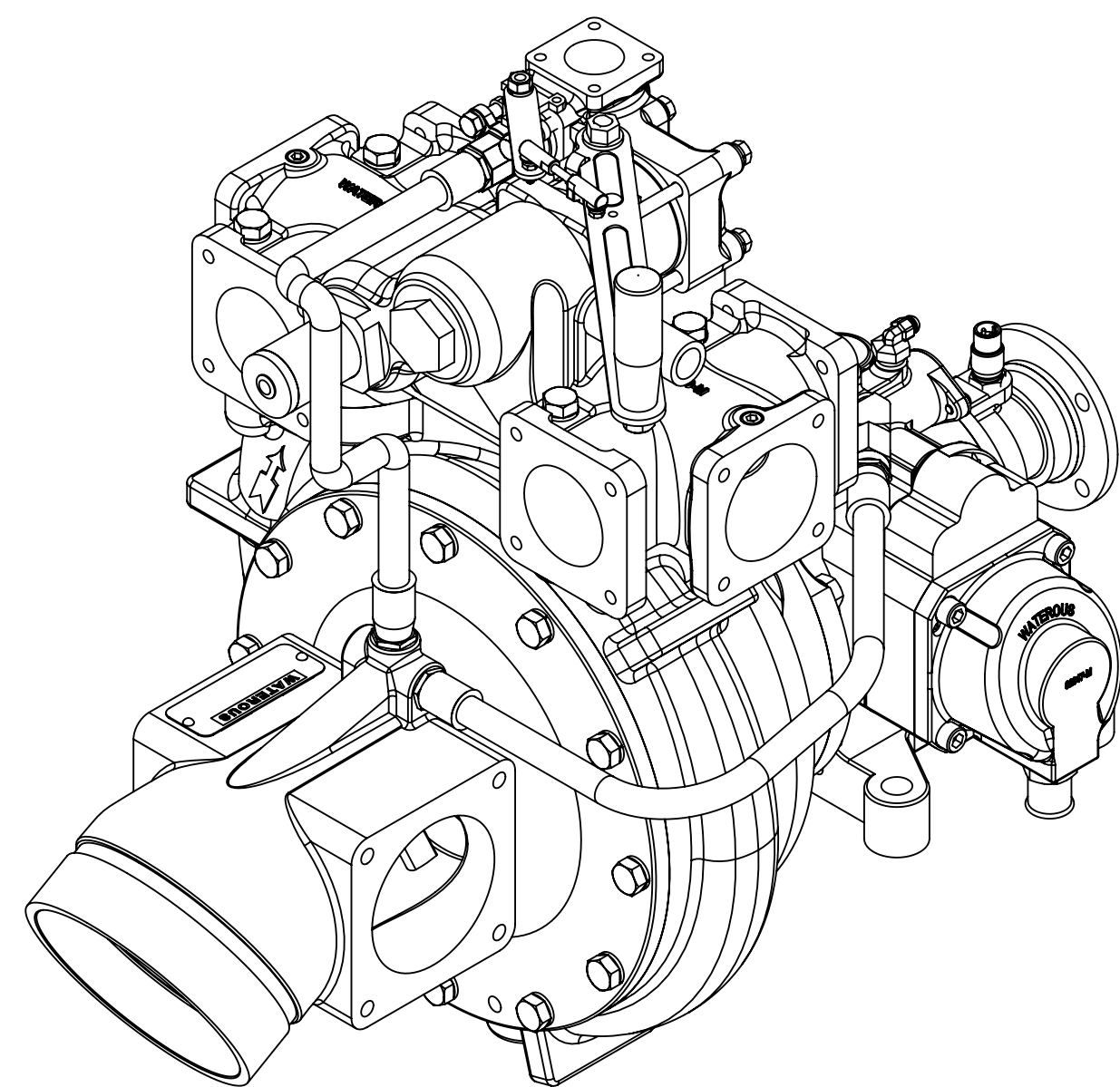

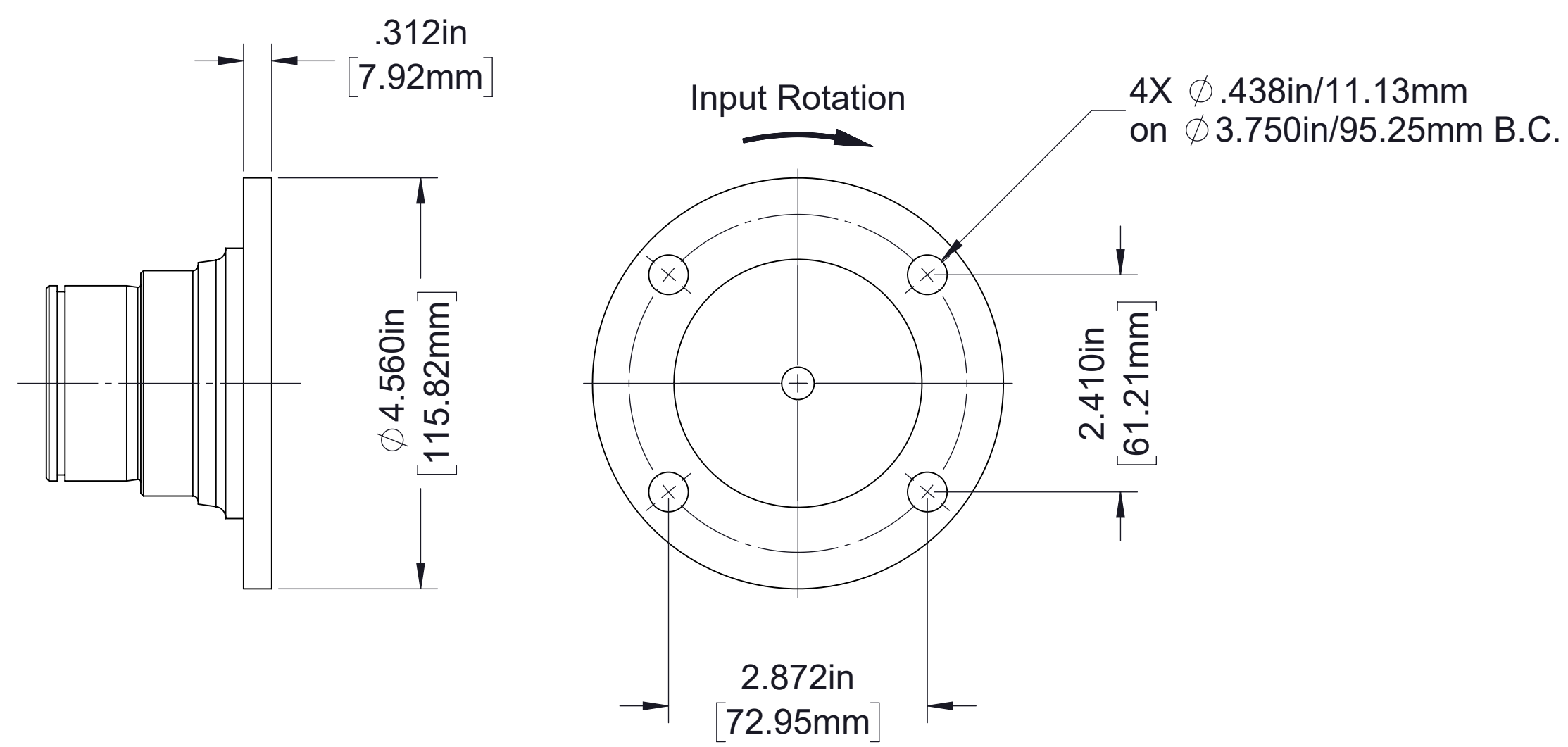

1410 Series Companion Flange Detail

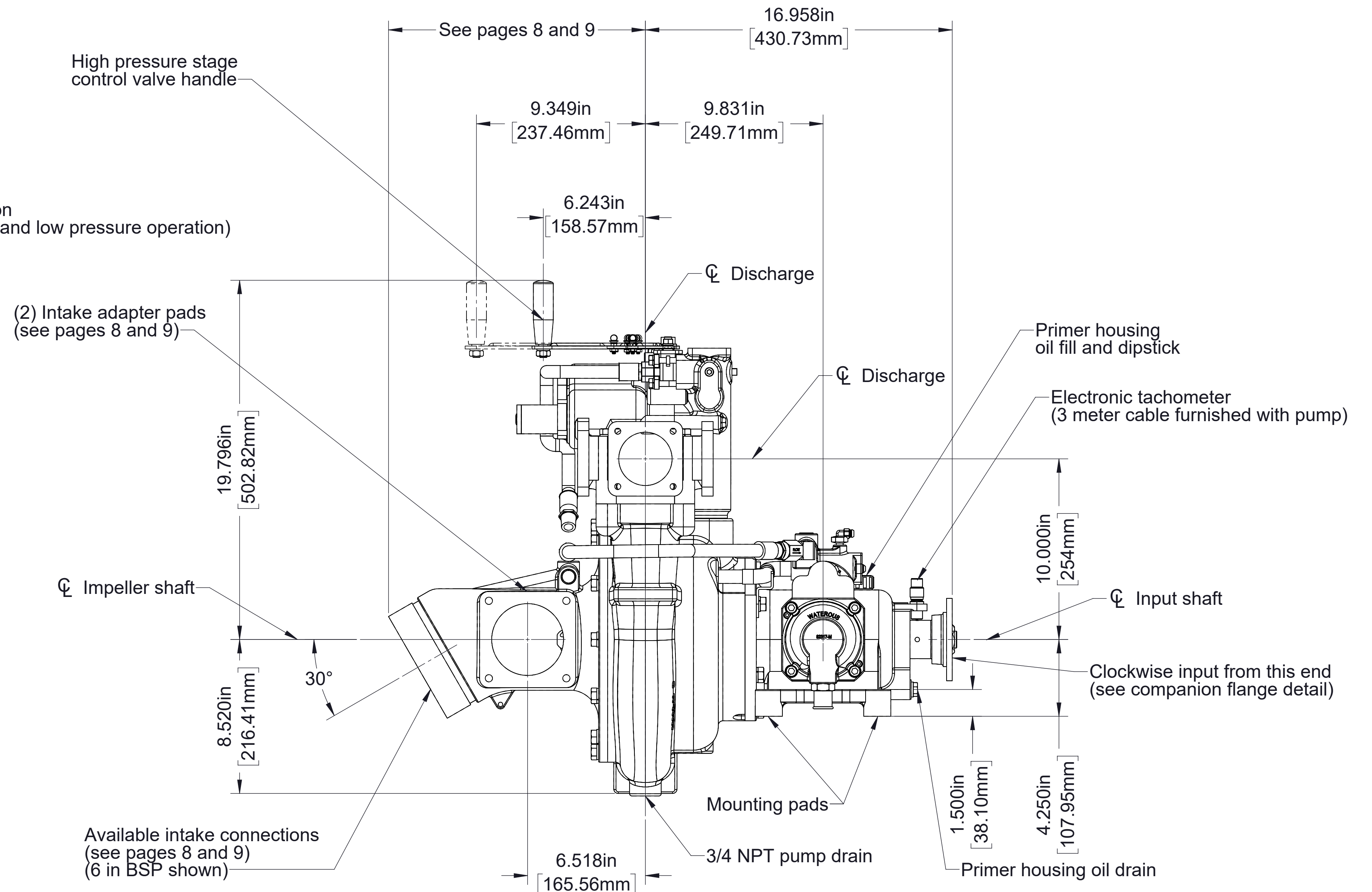
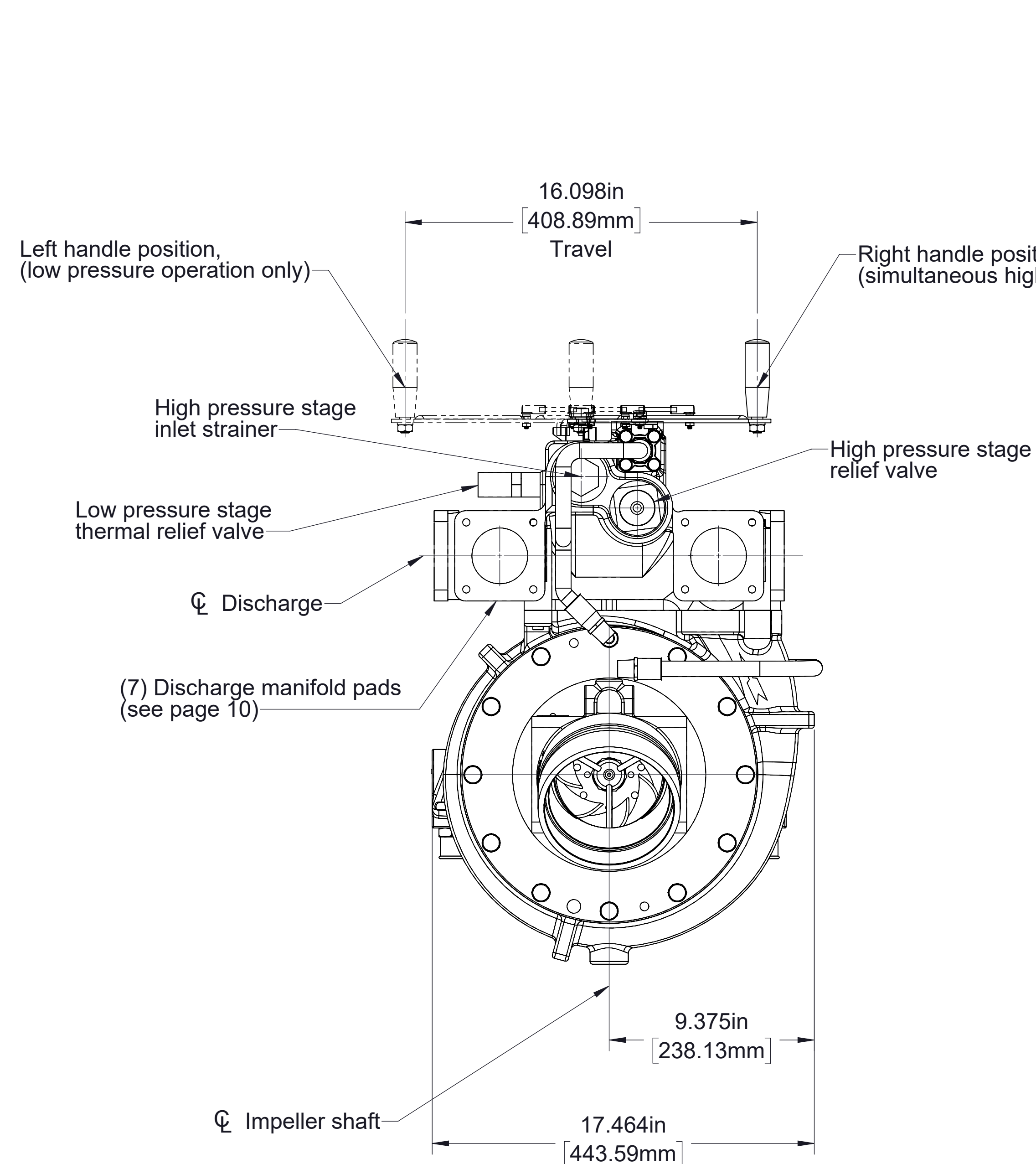
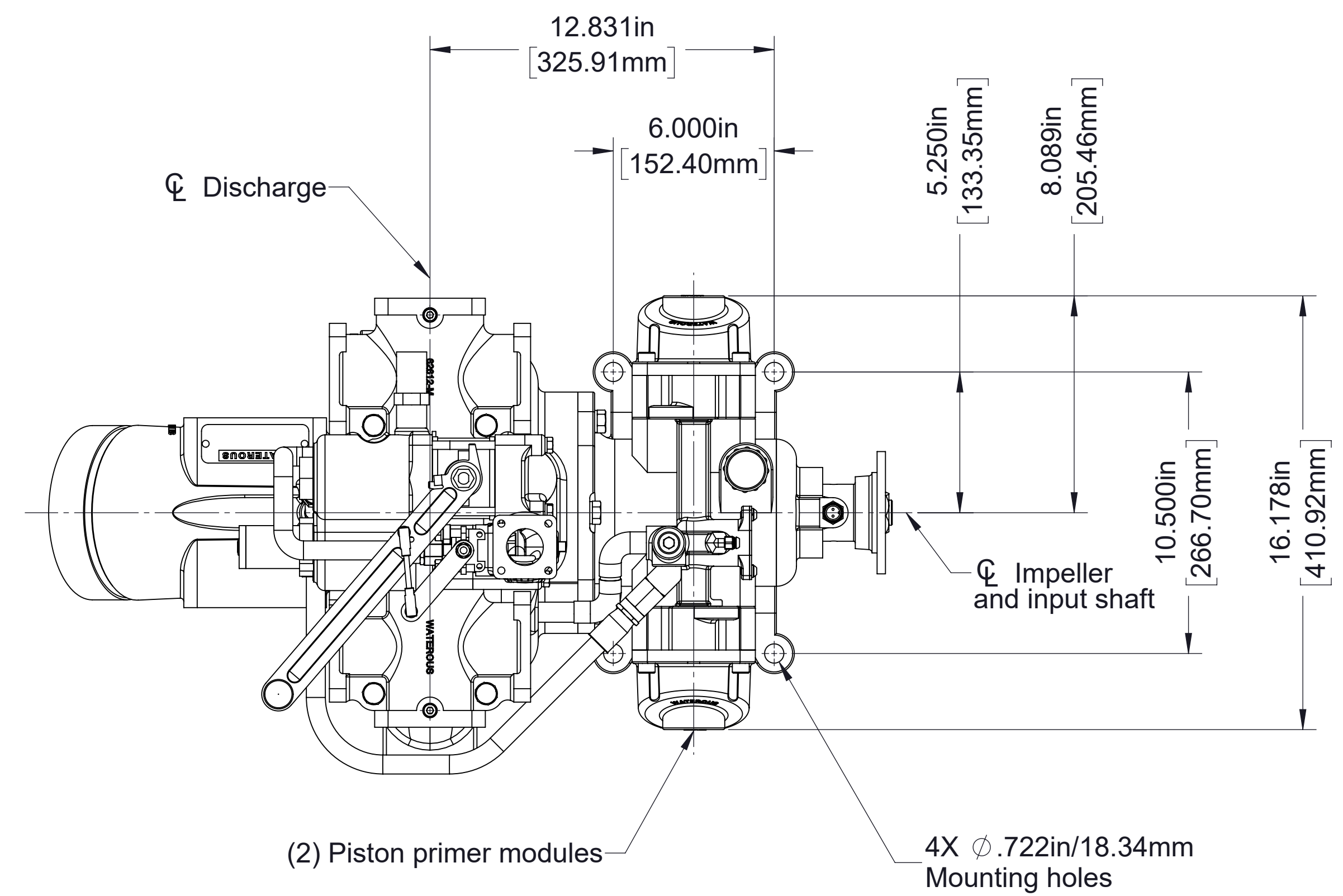

**HL200D/HL300D Pump
Clockwise Input Rotation**

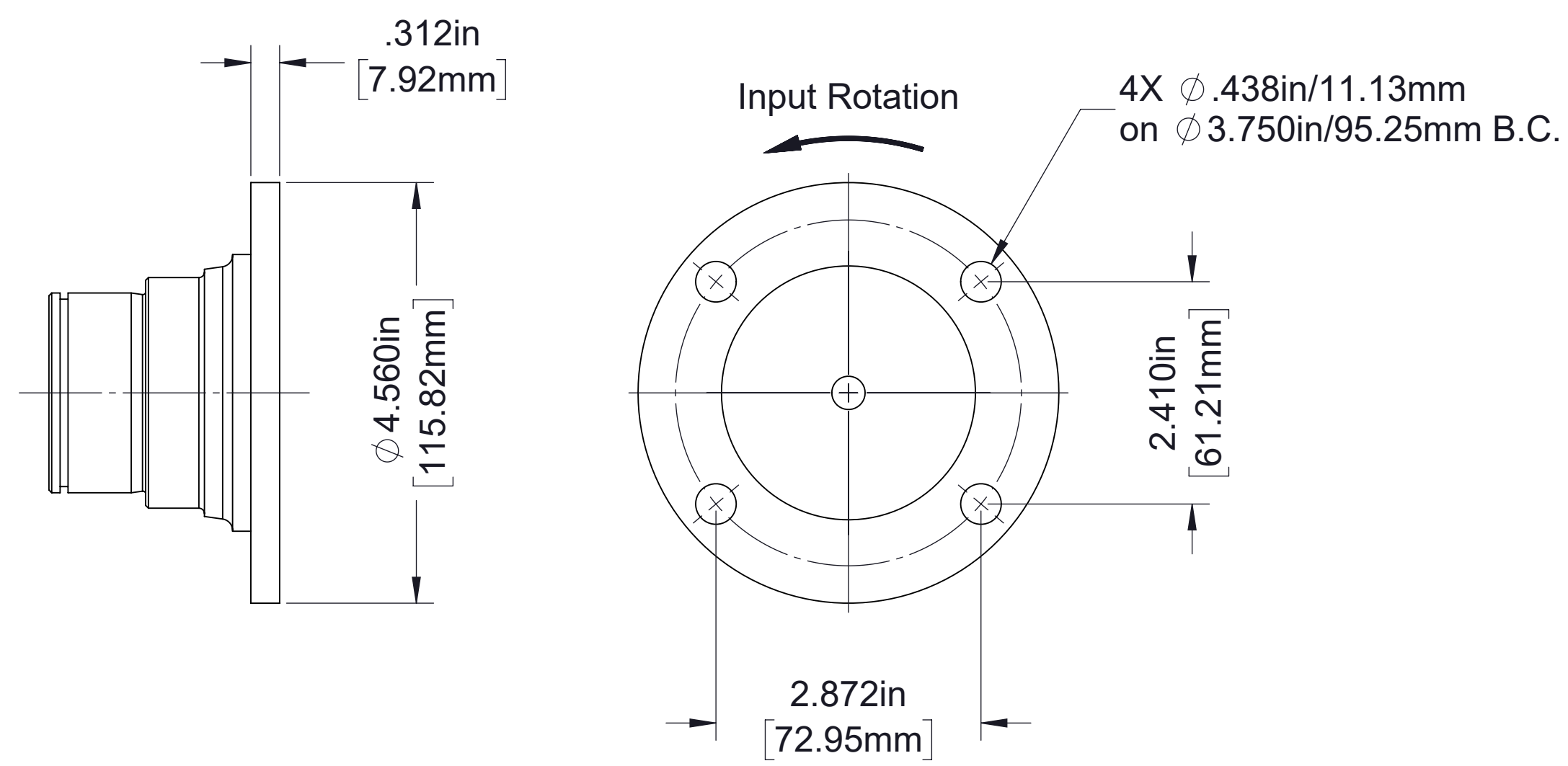

1410 Series Companion Flange Detail

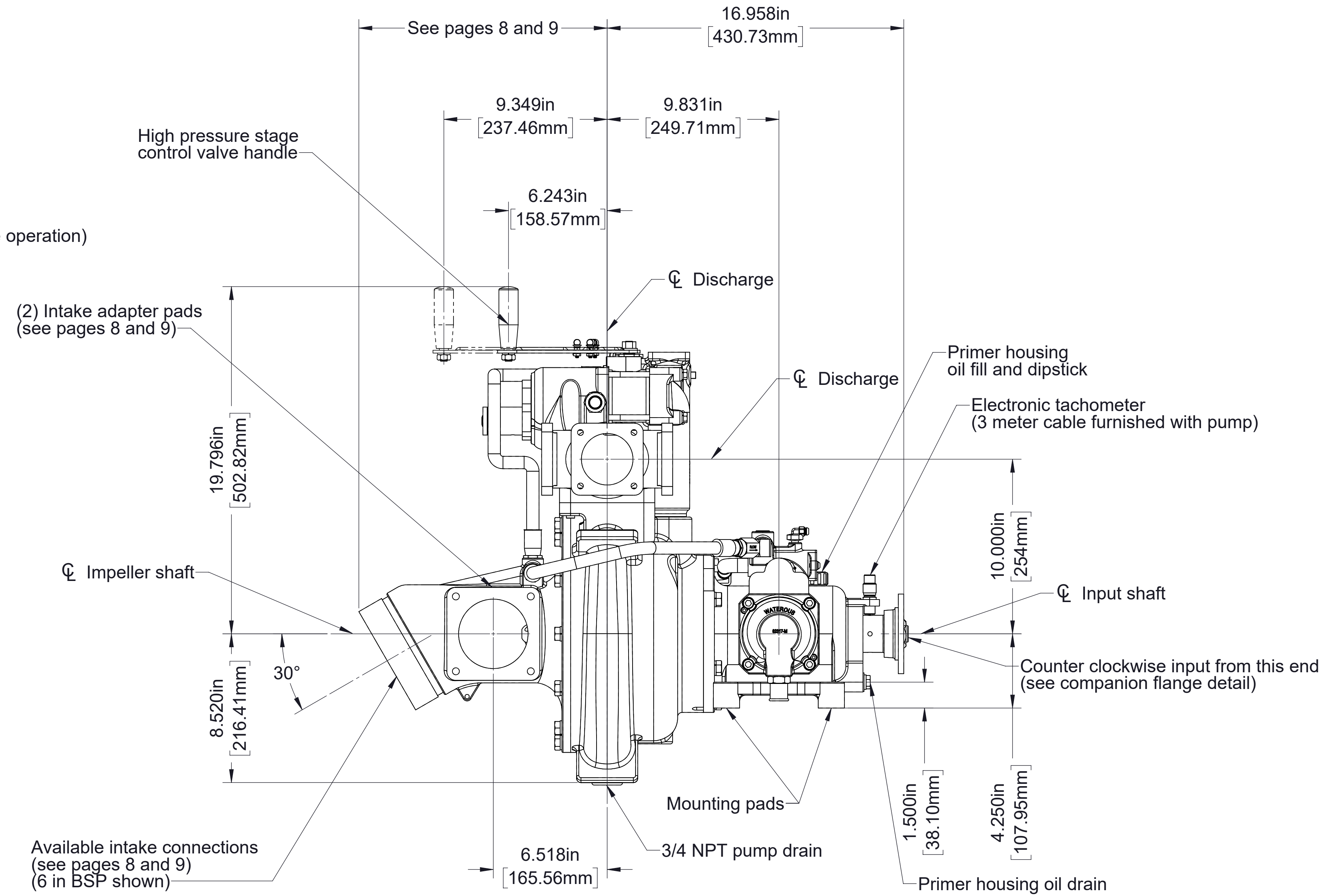
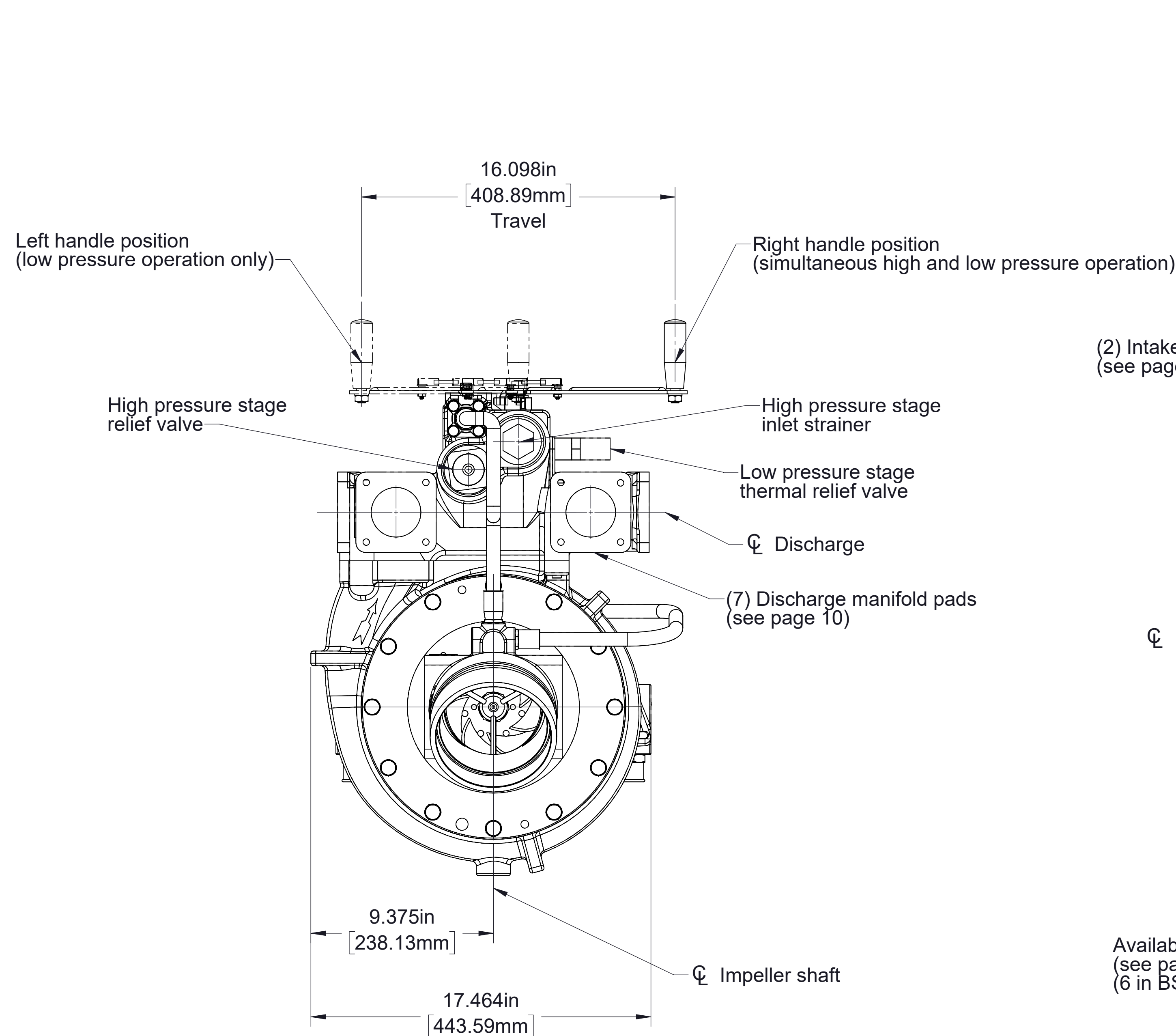
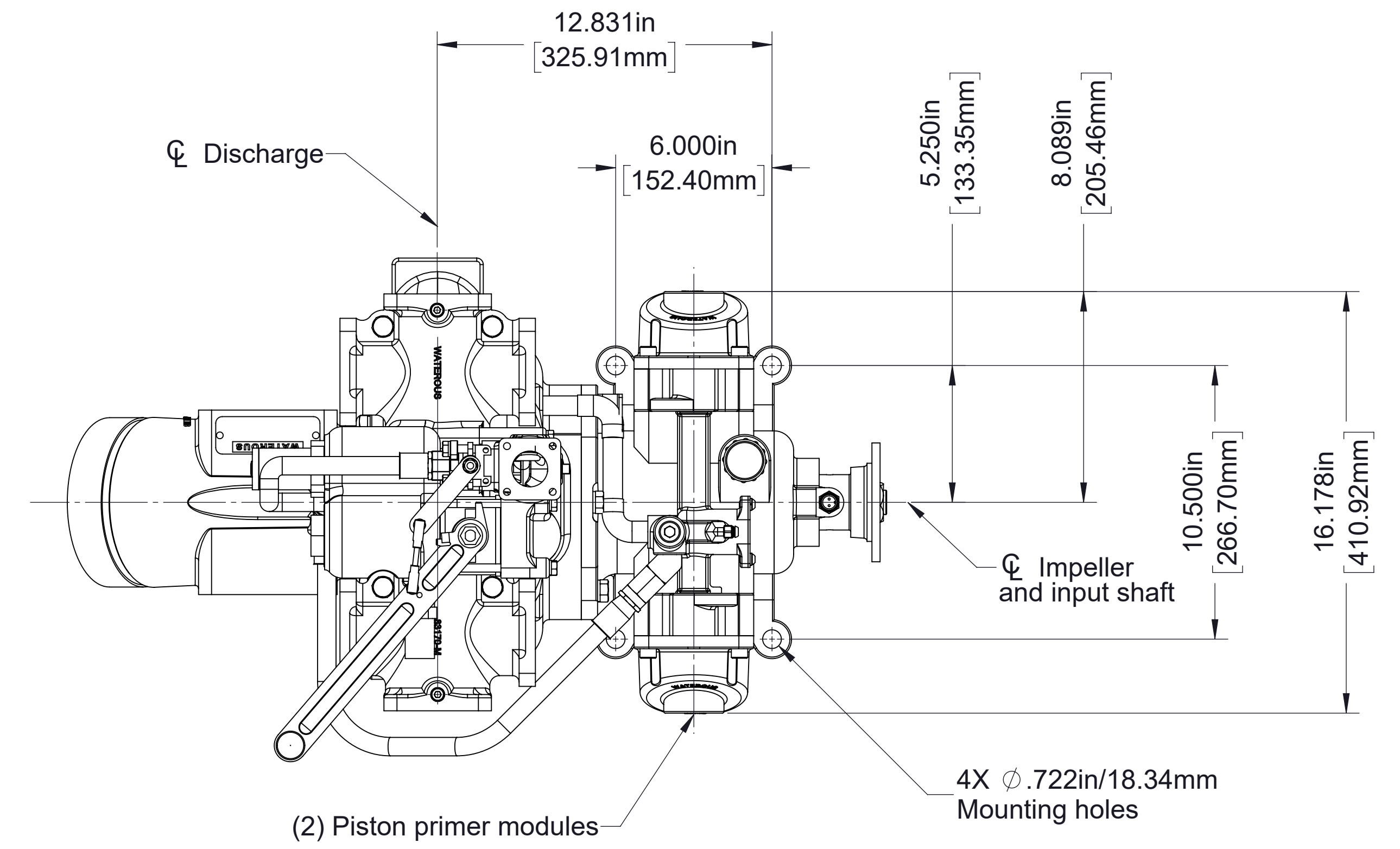

**HL200D/HL300D Pump
Counter Clockwise Input Rotation**

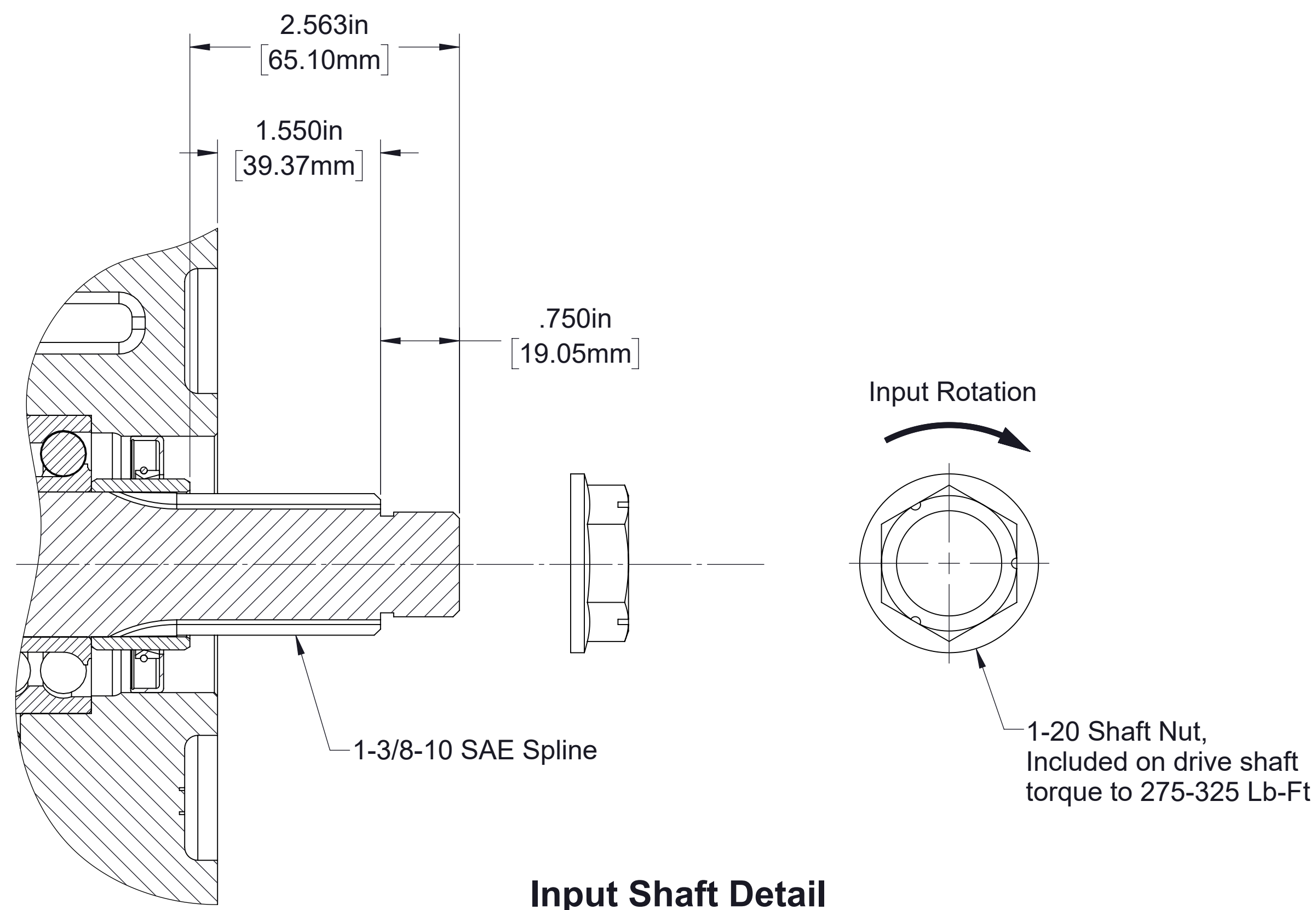

Input Shaft Detail

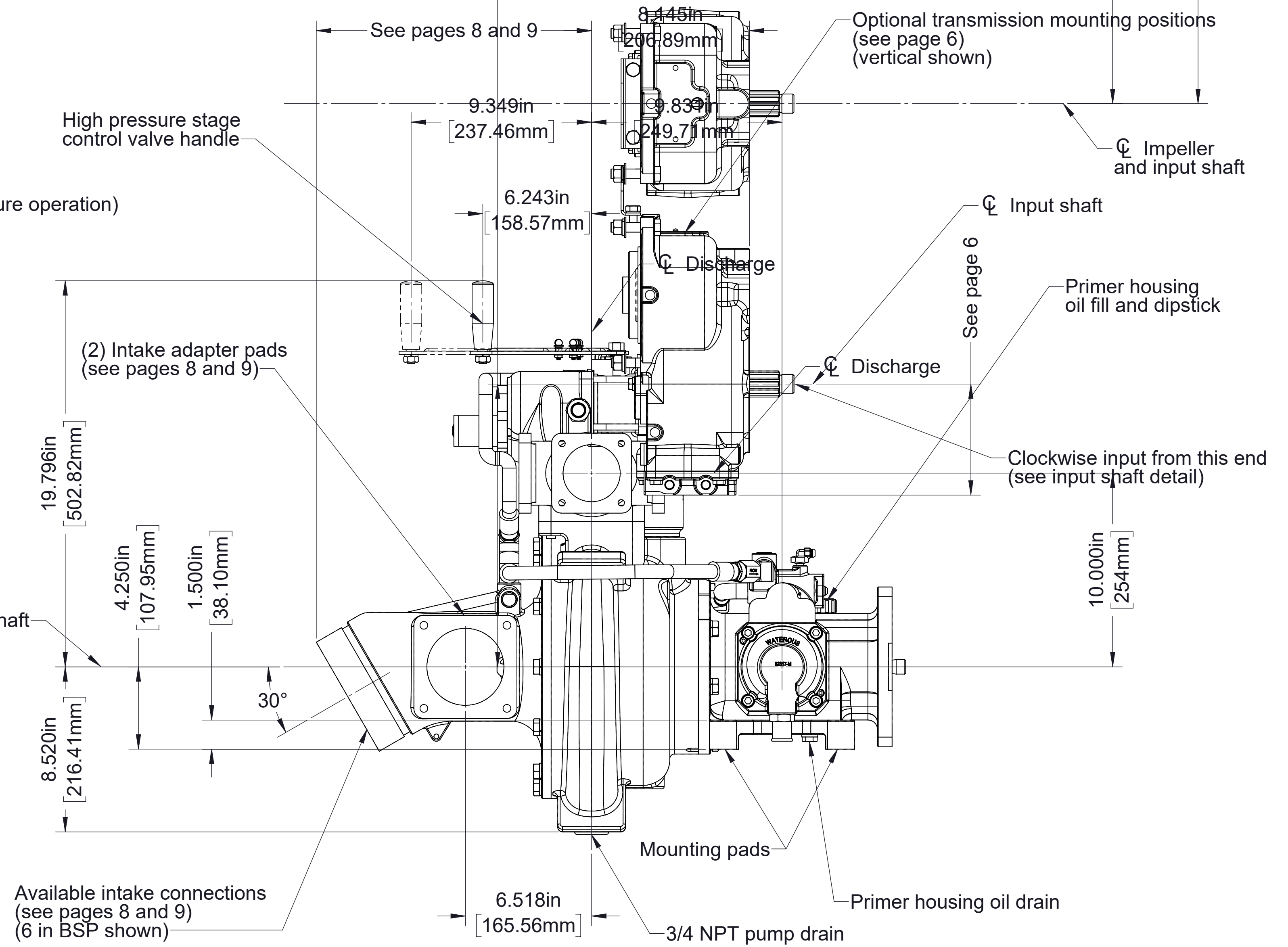
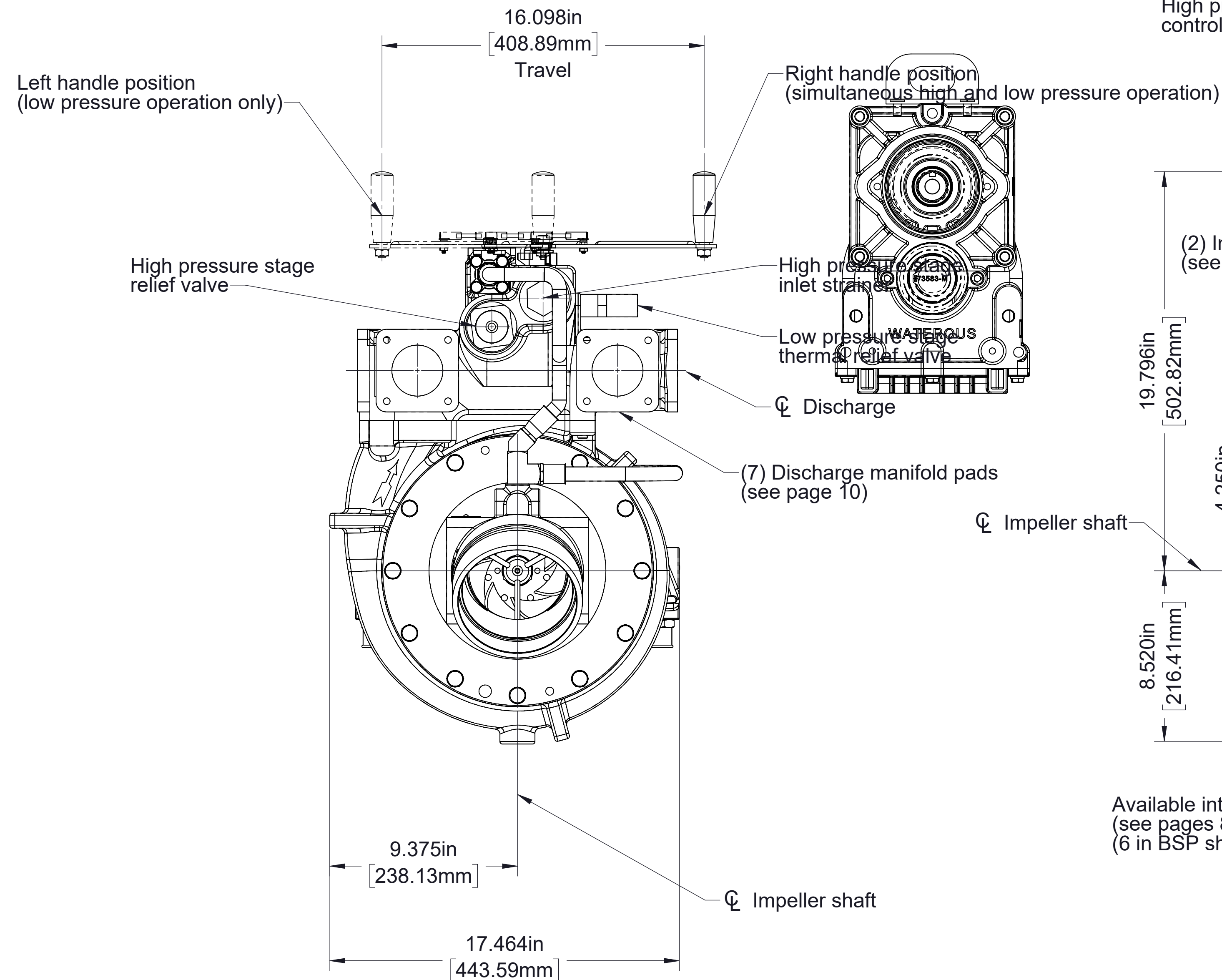
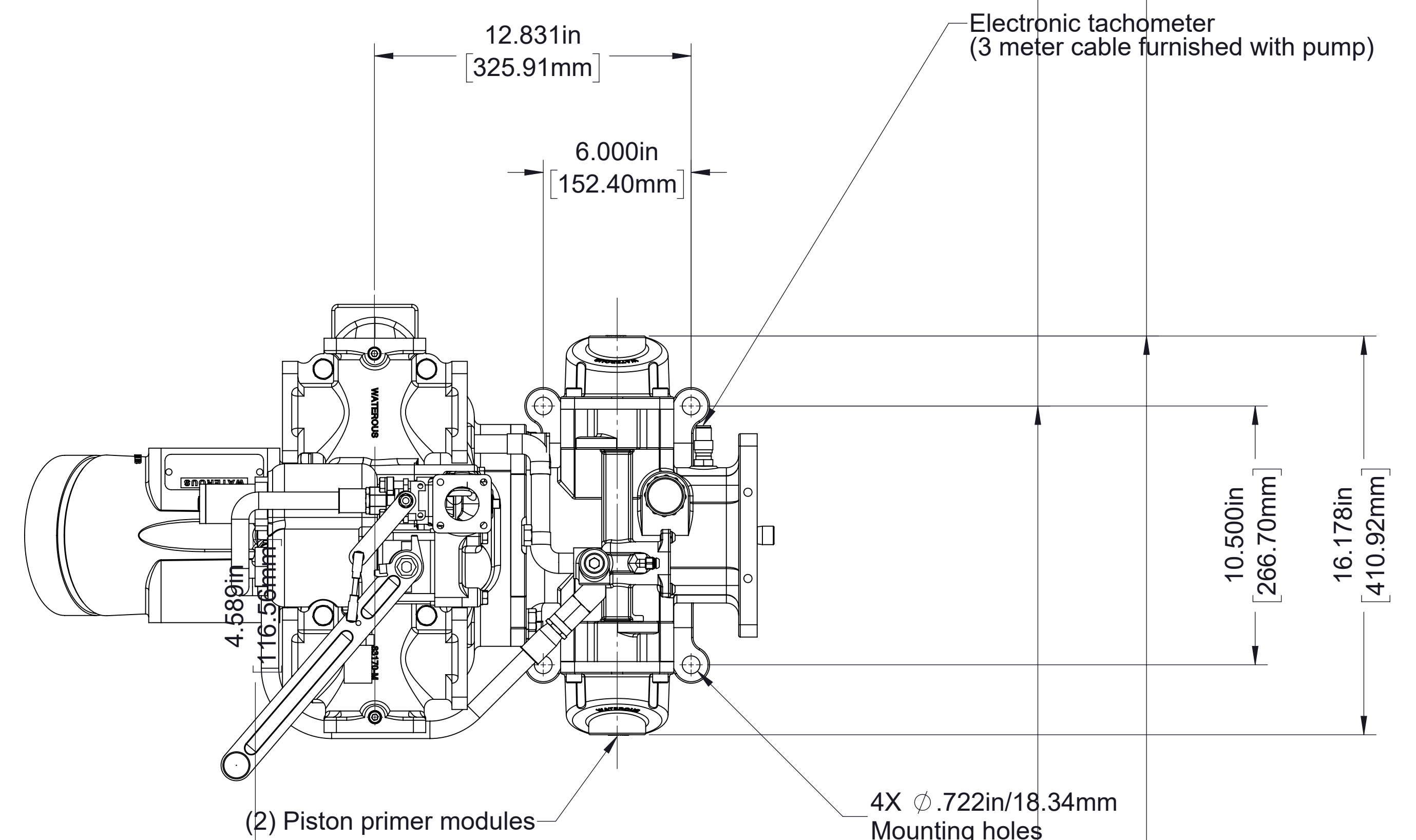

**HL200K/HL300K Pump
Clockwise Input Rotation**

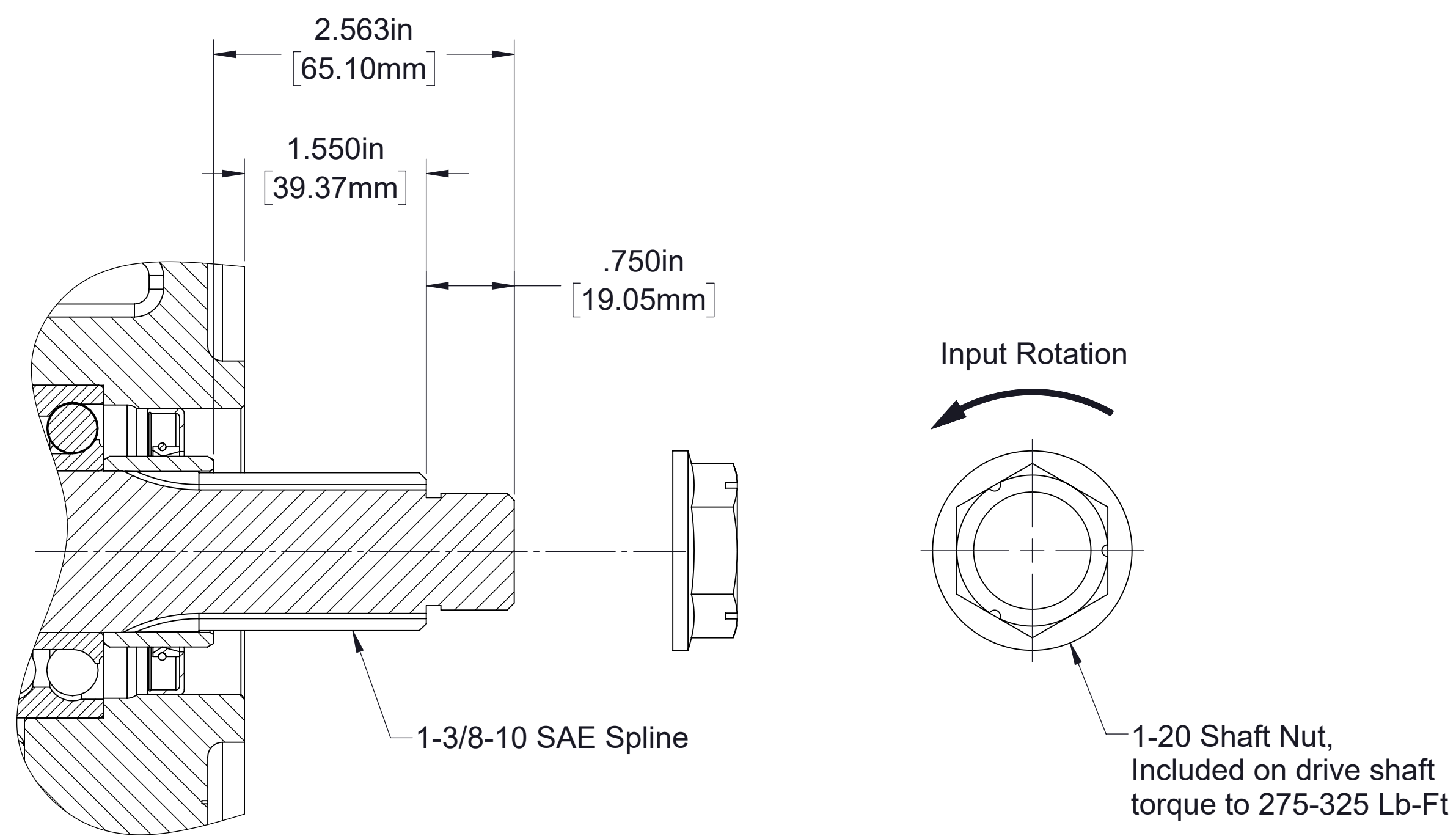

Input Shaft Detail

1-20 Shaft Nut,
Included on drive shaft
torque to 275-325 Lb-Ft

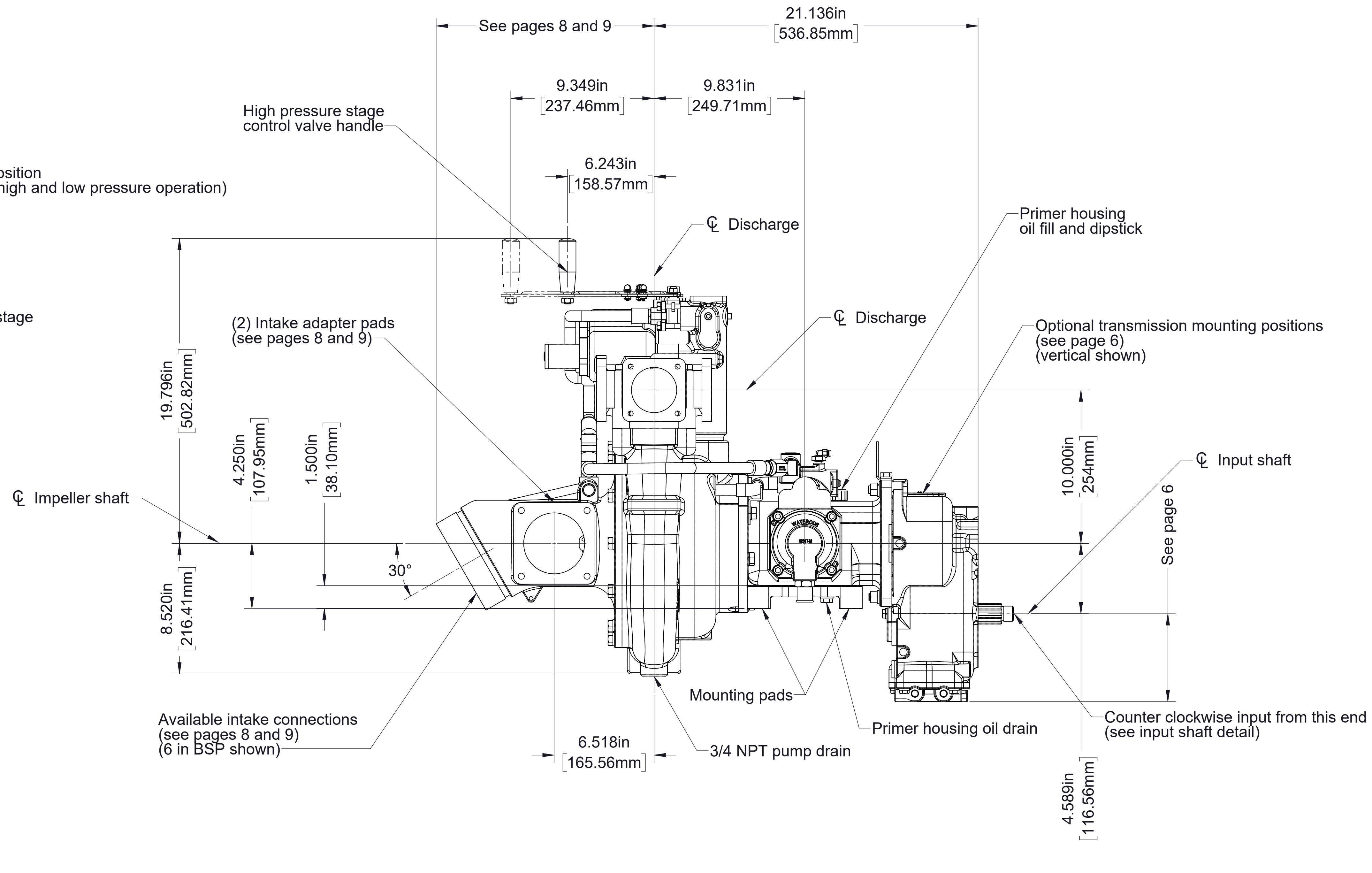
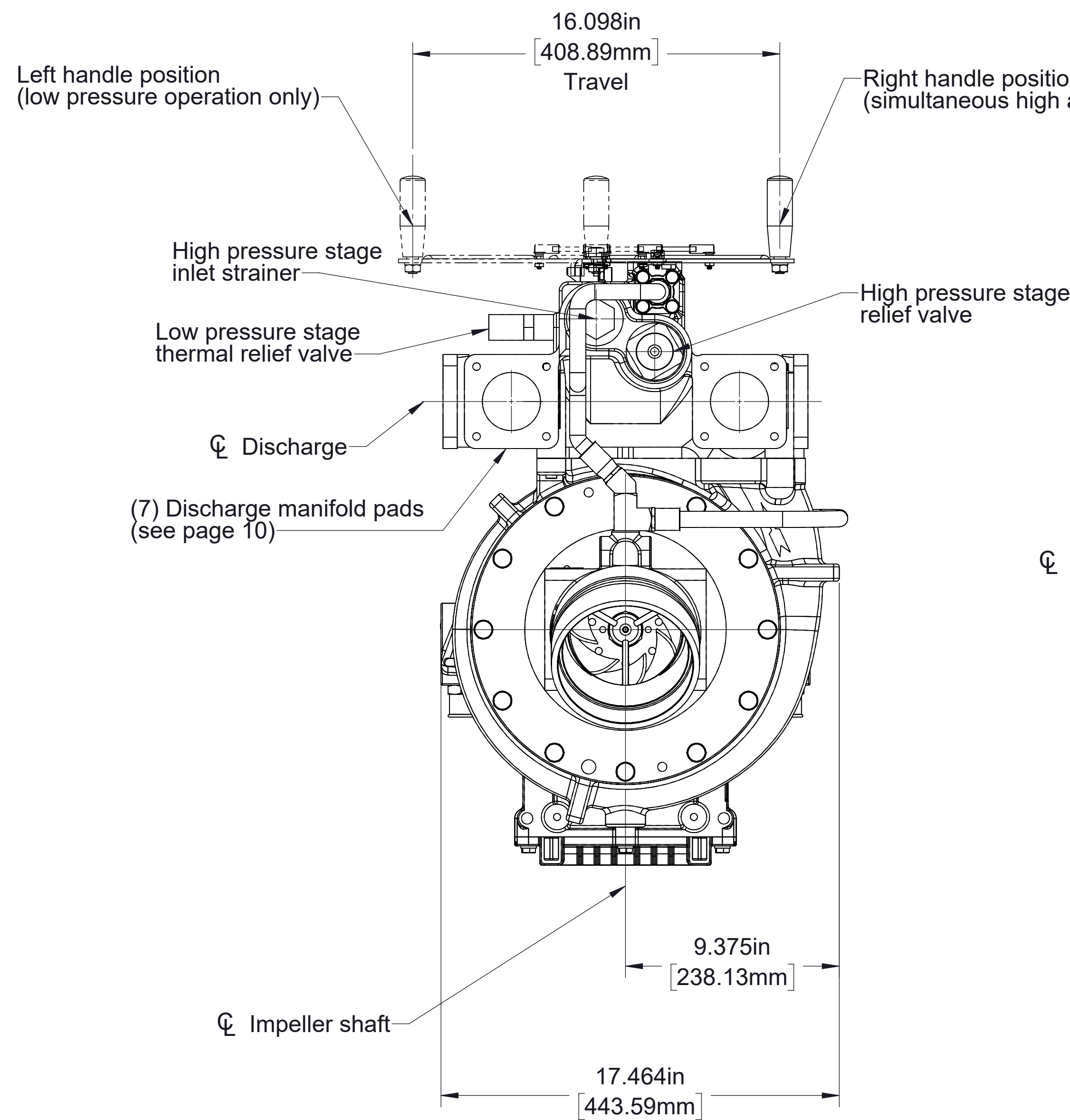
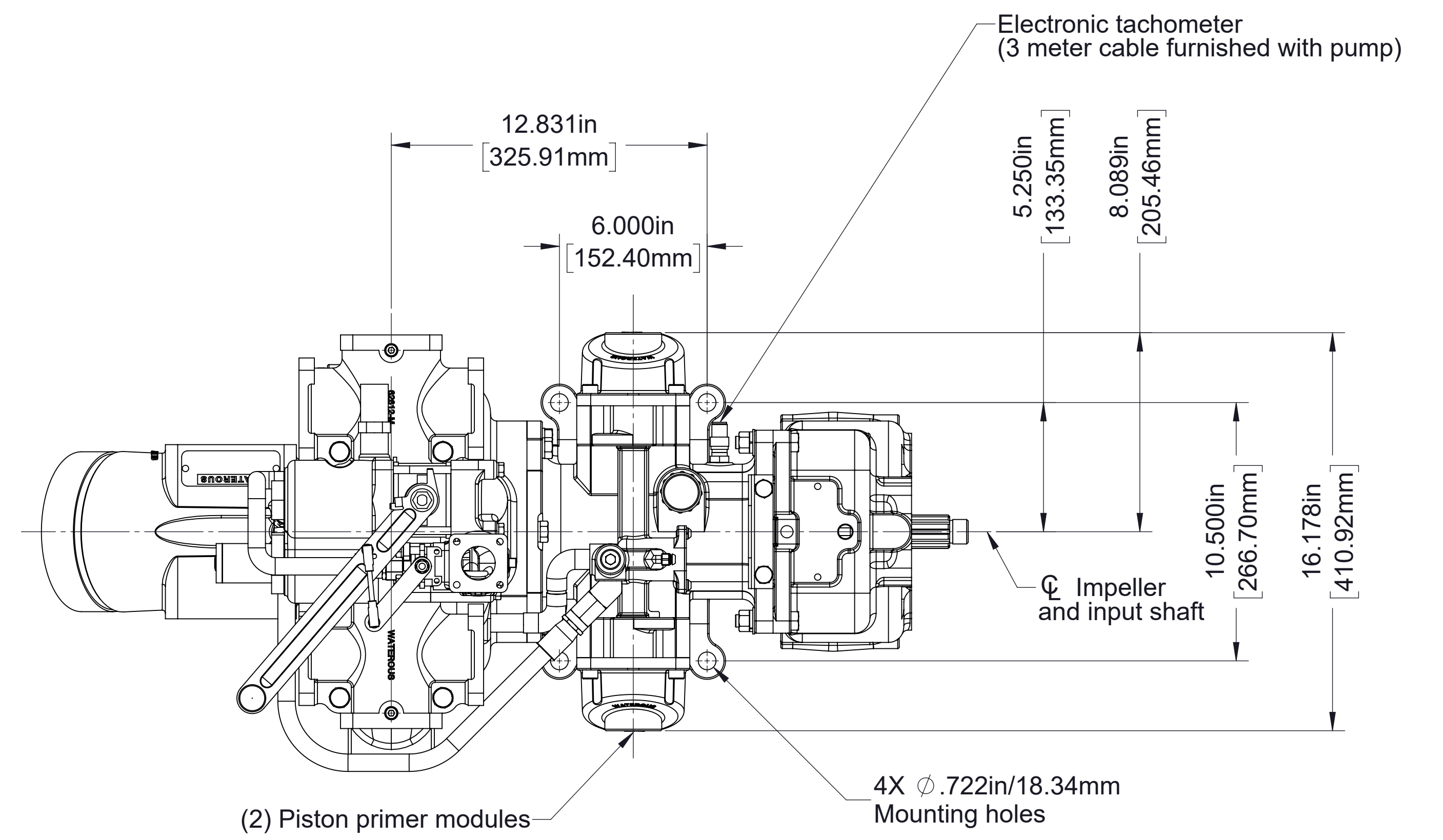

**HL200K/HL300K Pump
Counter Clockwise Input Rotation**

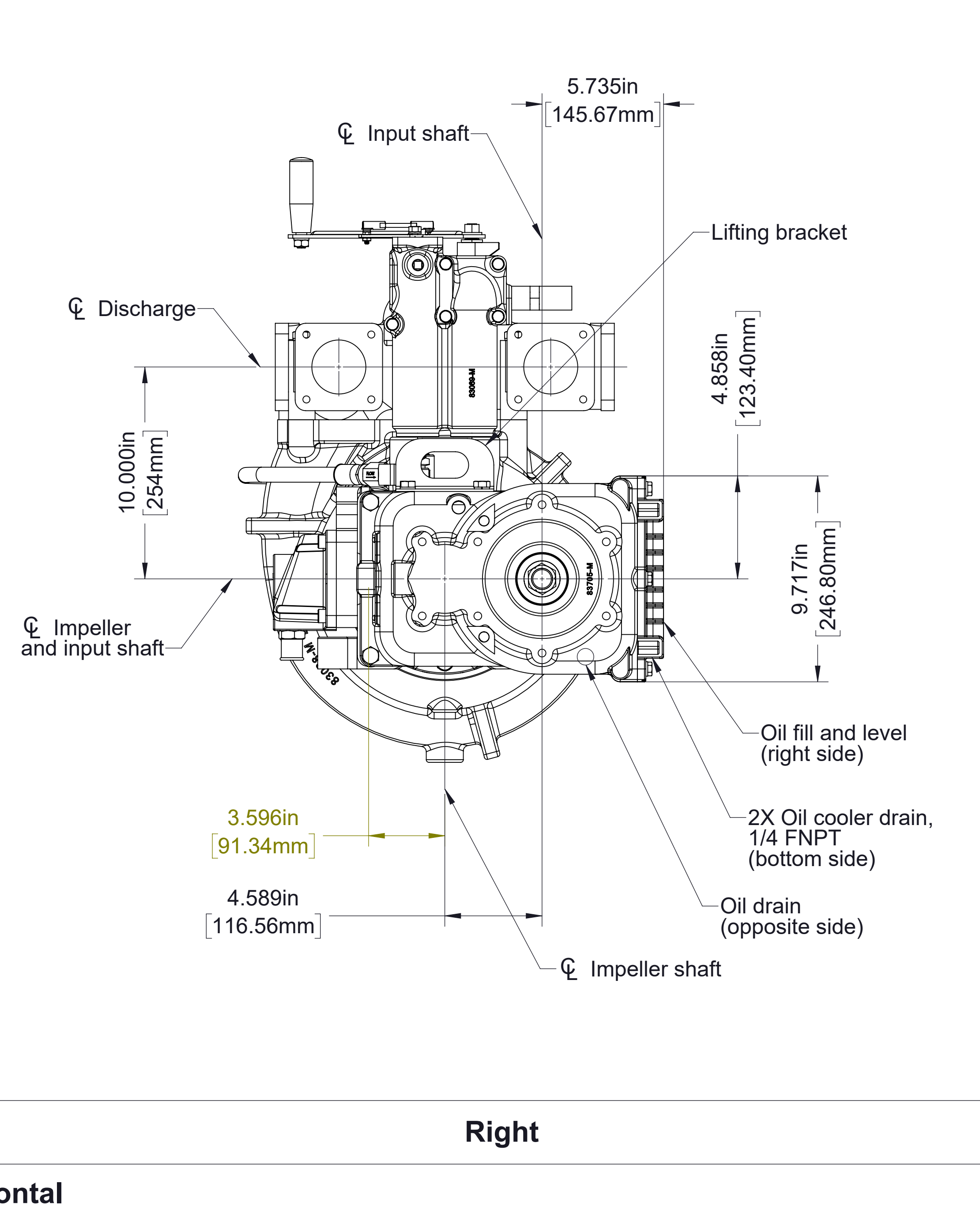
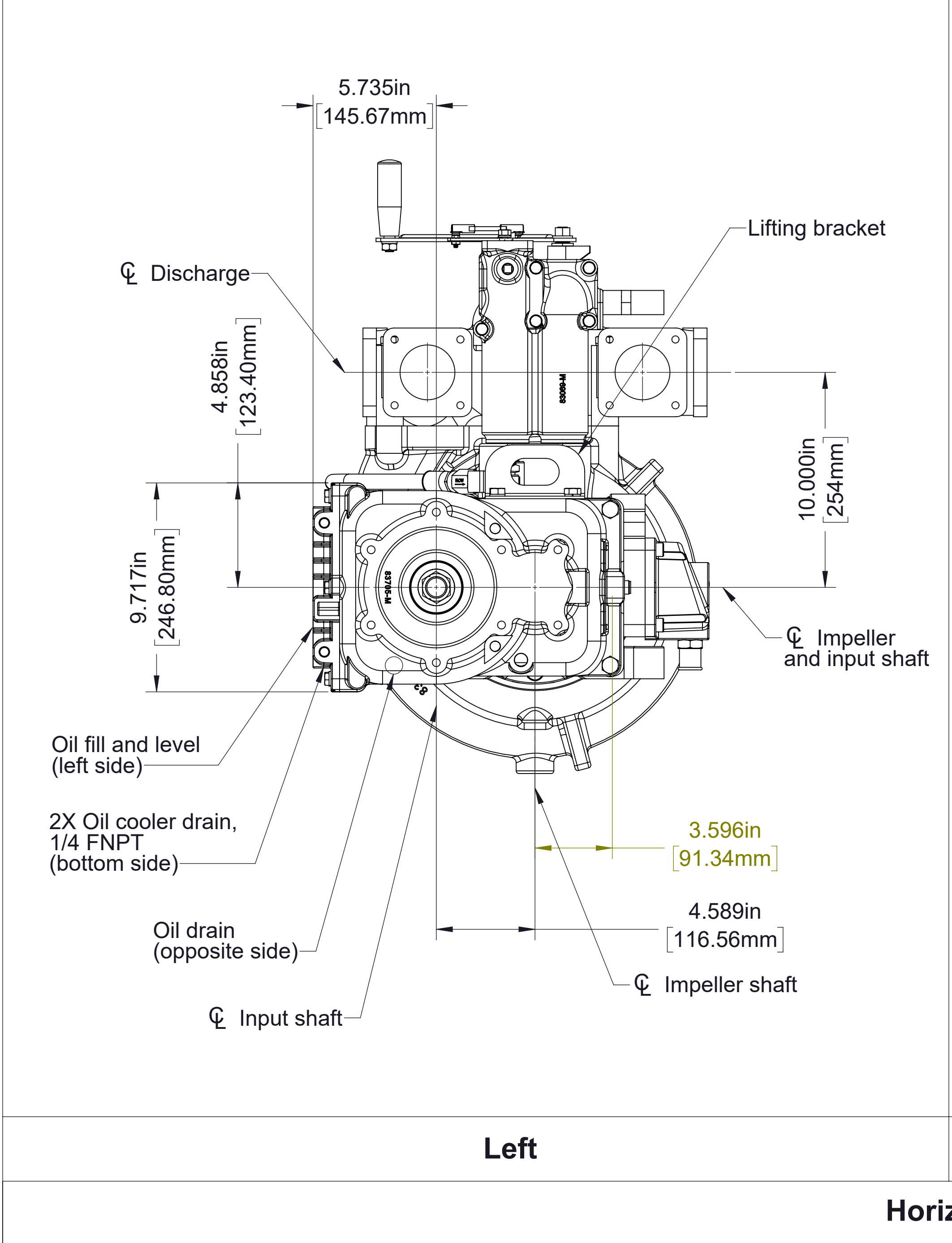
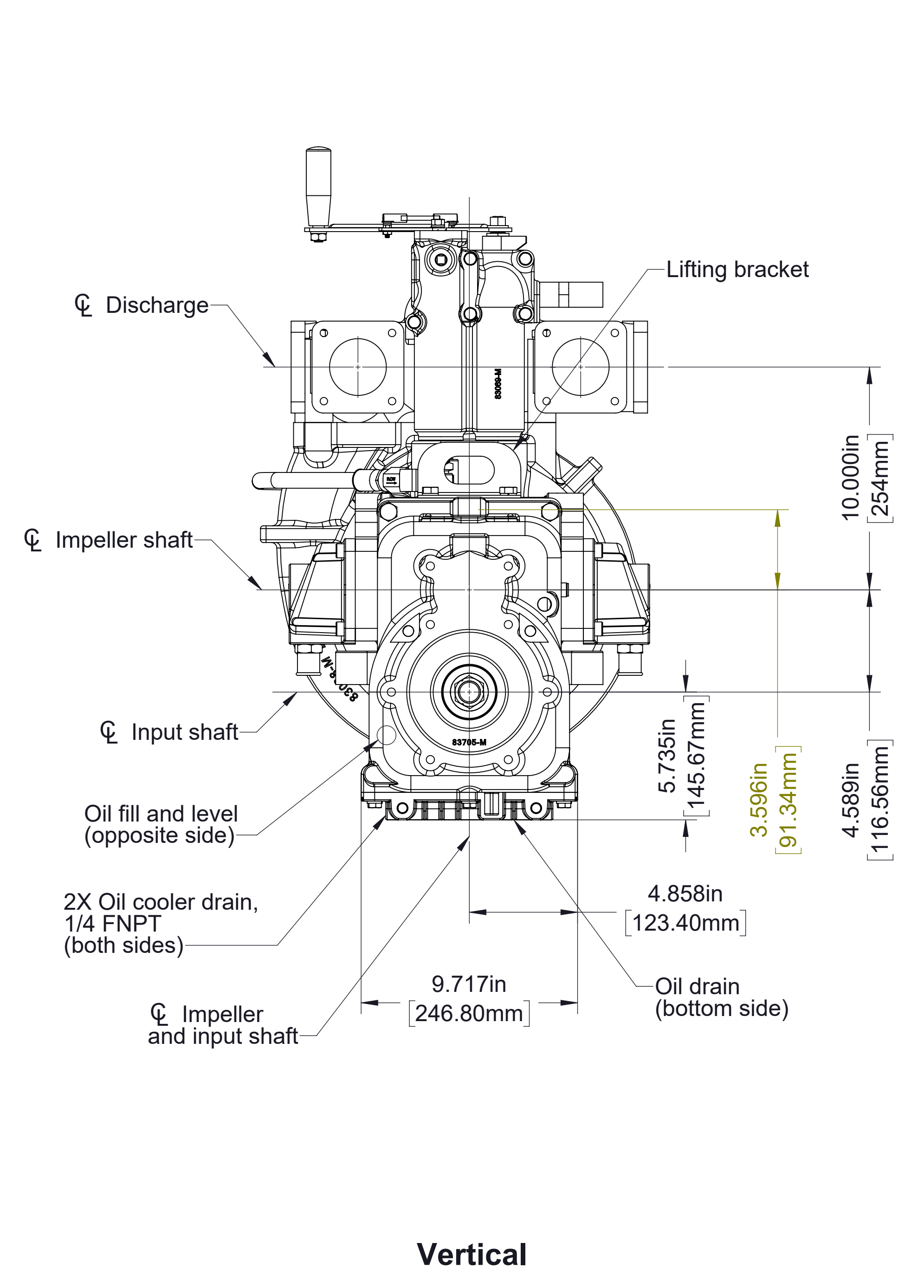

Transmission Mounting Positions
 (Defined as viewed from drive end of pump)

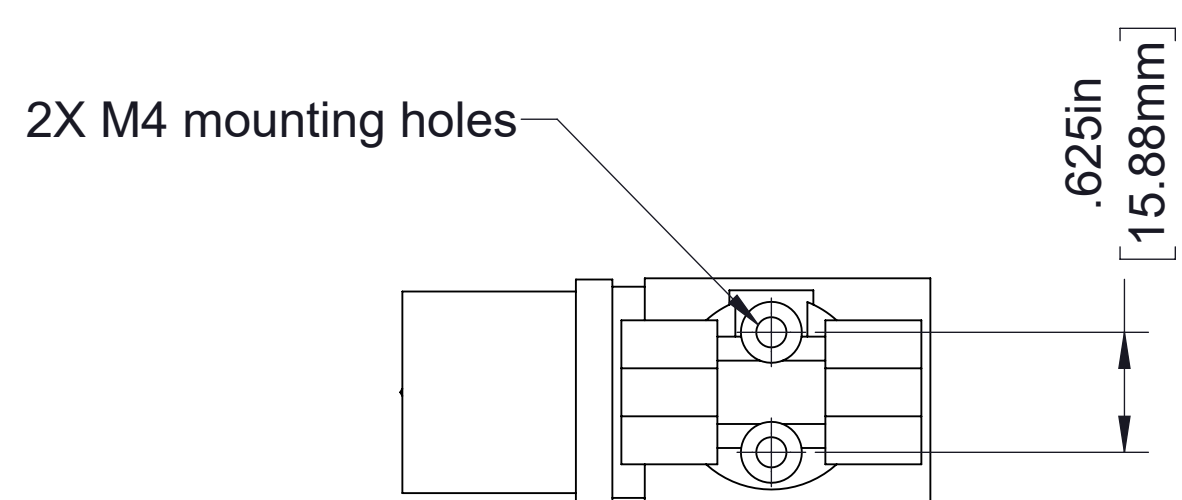
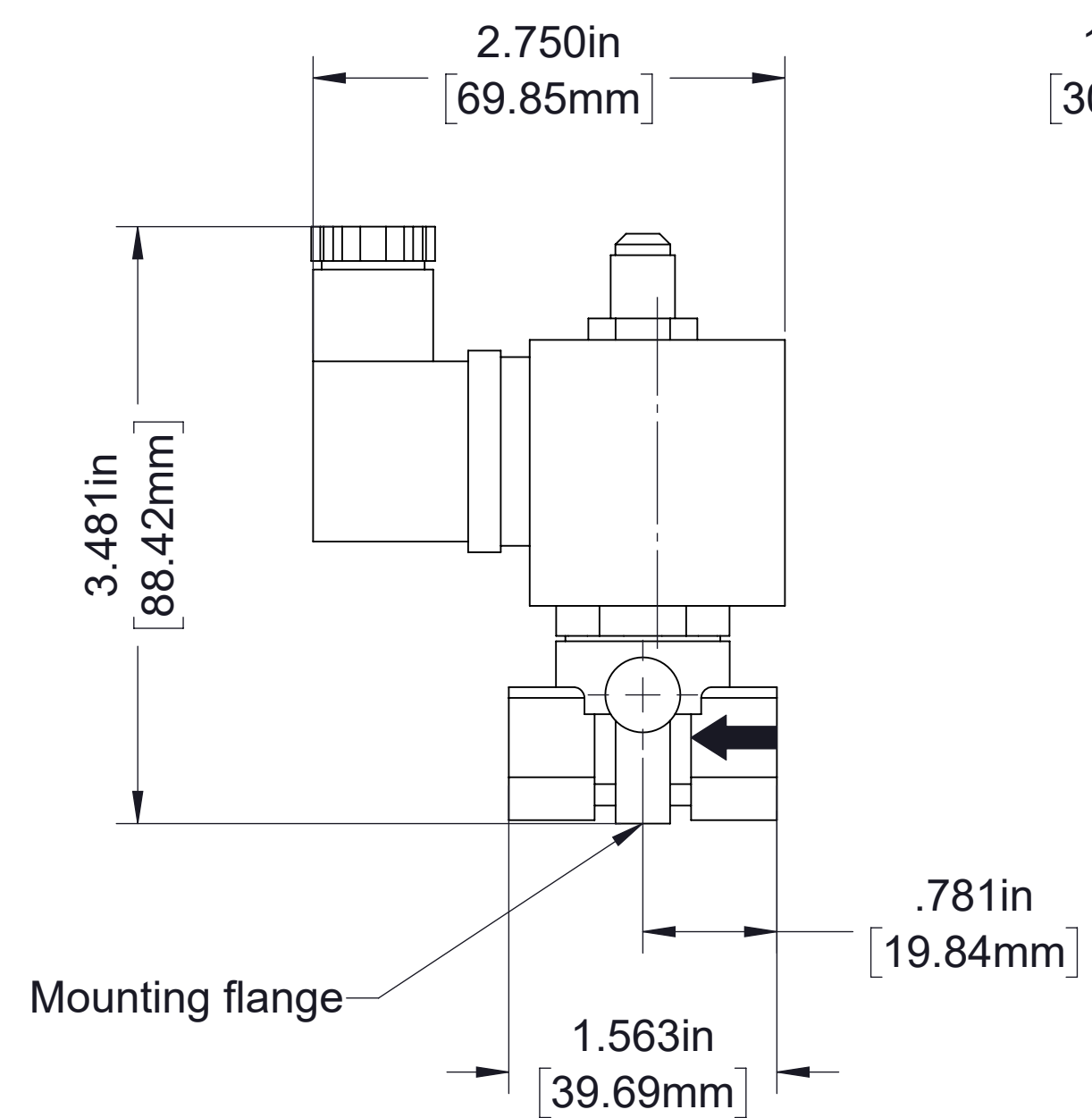
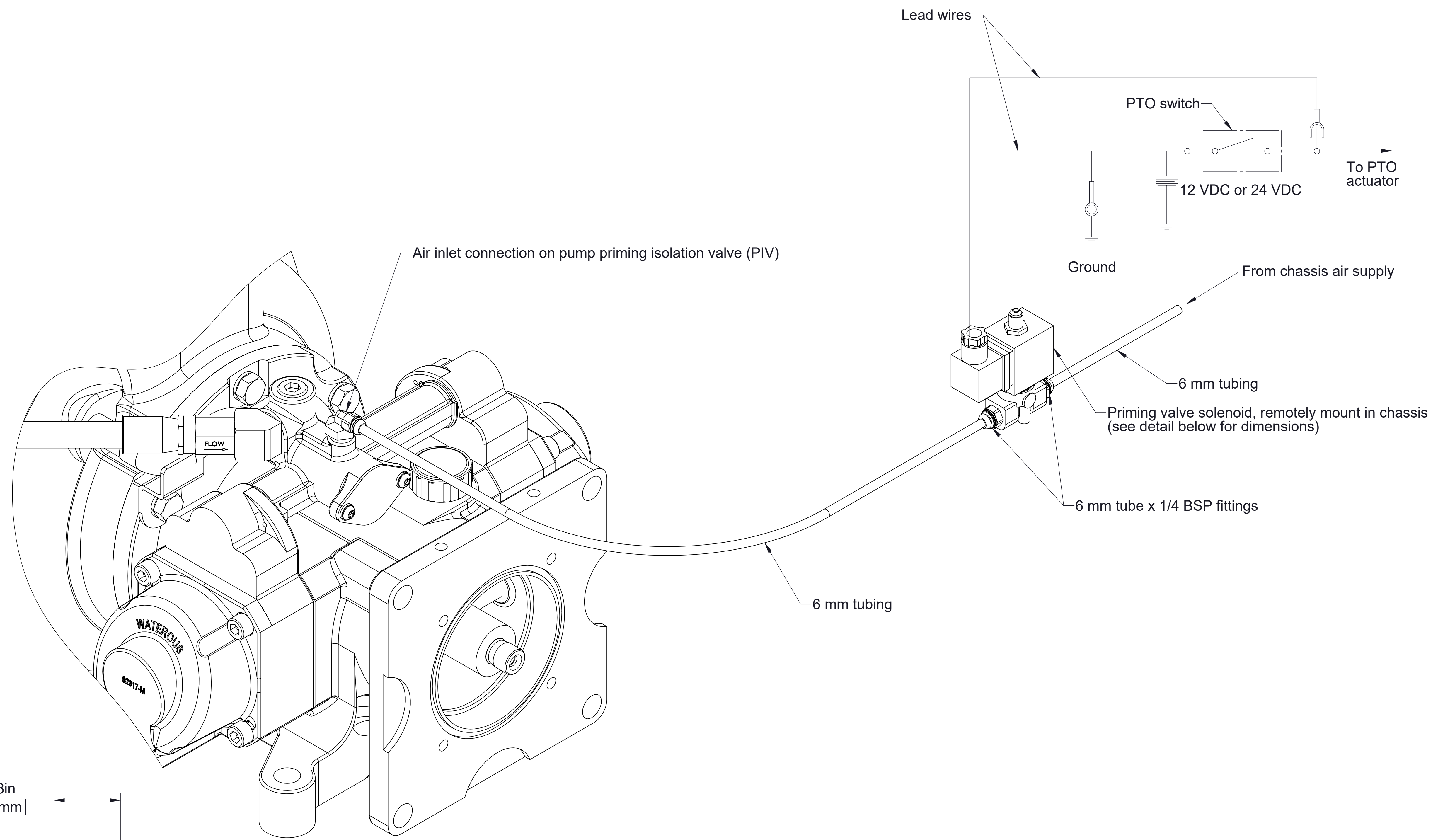

Components Required		
Quantity	Item	Furnished By:
1	Solenoid	Waterous
2	6 mm tube x 1/4 BSP fitting	Waterous
3 meters	6 mm tubing	Waterous
All	Wiring (16 or 18 AWG)	Truck builder
1	PTO switch	Truck builder
All	Connectors to chassis air supply	Truck builder

Priming Isolation Valve (PIV) Solenoid Valve

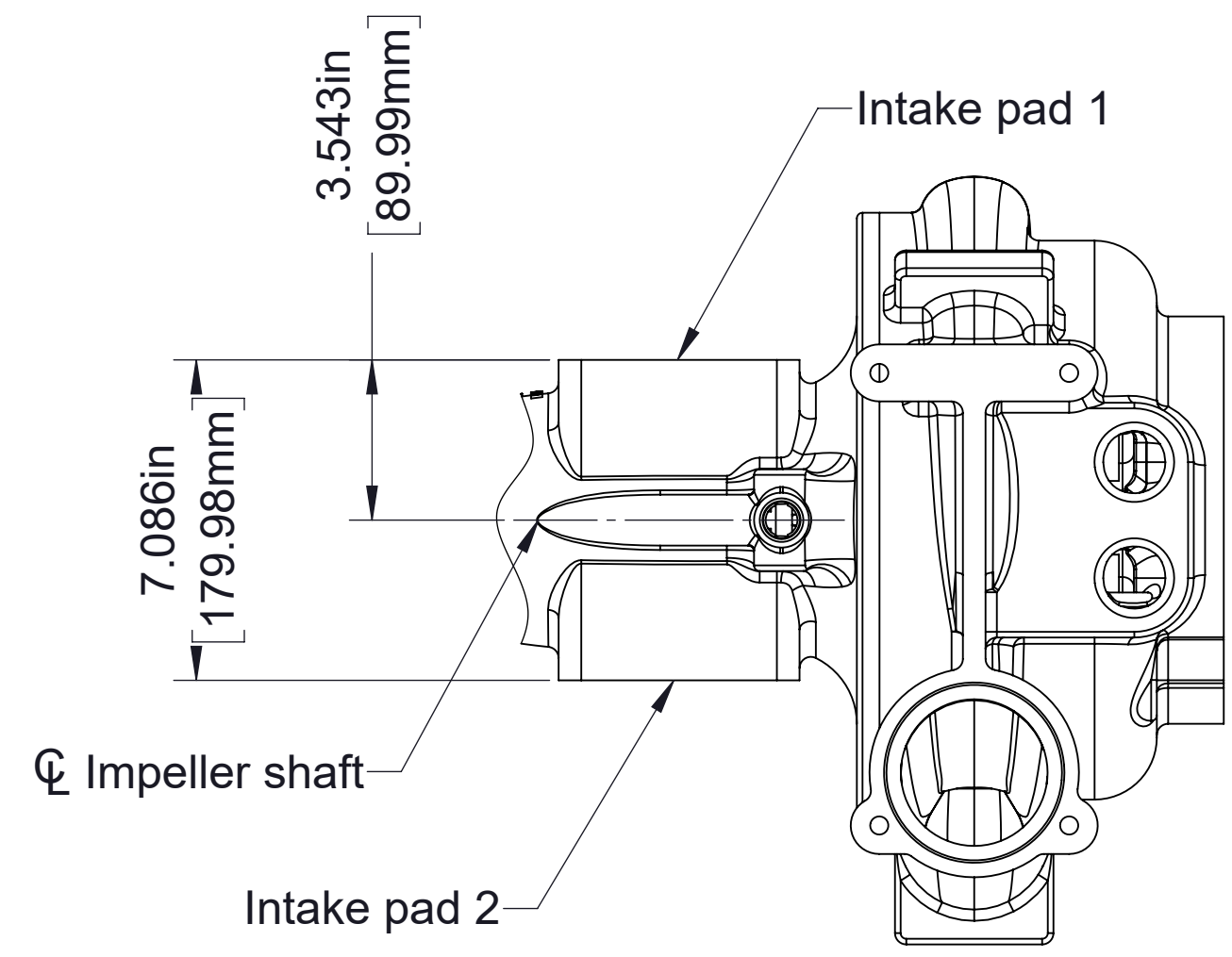

(Top view of Pump and Intake)
Dimensions typical for all HL series intake connections
 See detail A for dimensions of pad 1 and 2

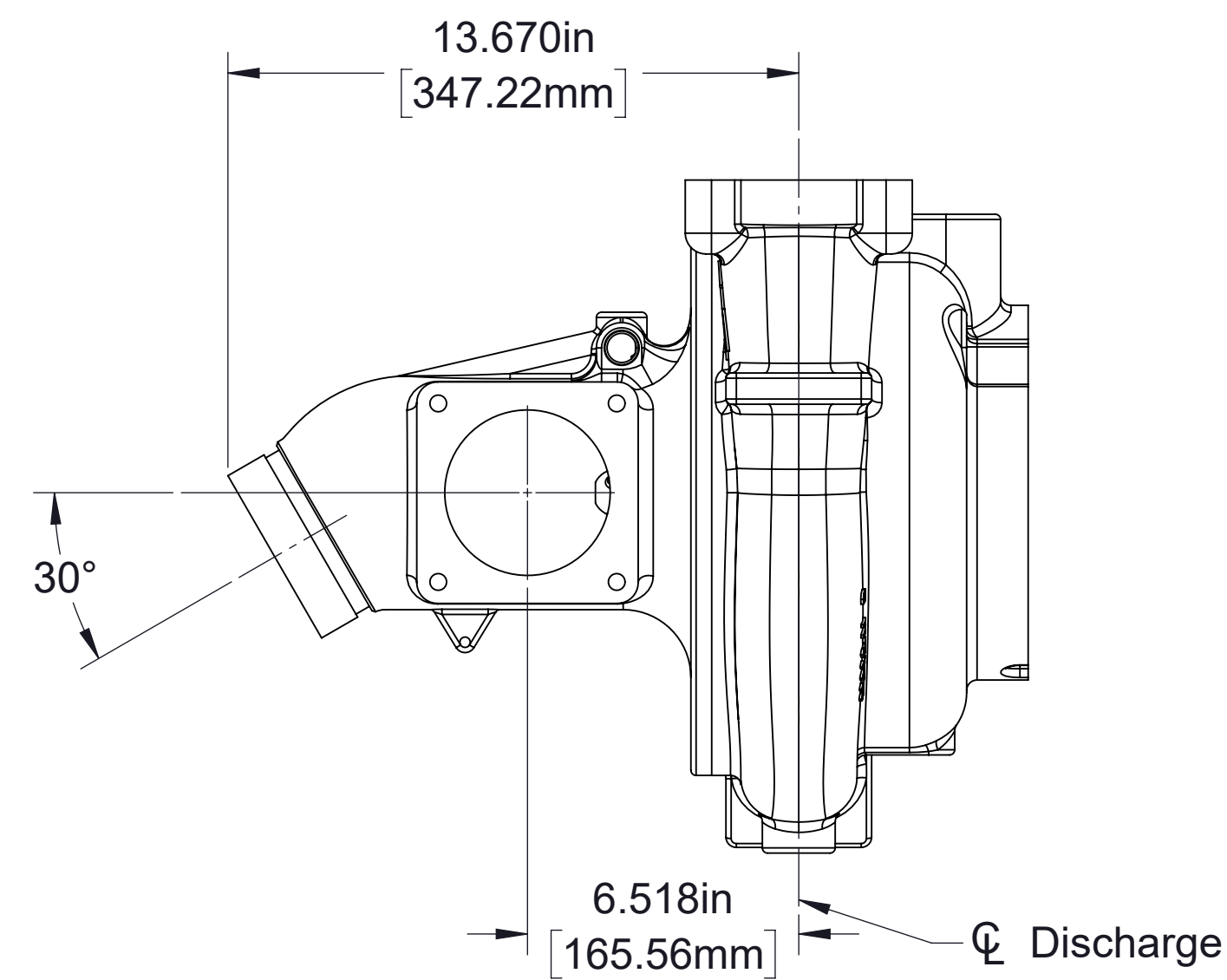

4 in BSP Thread

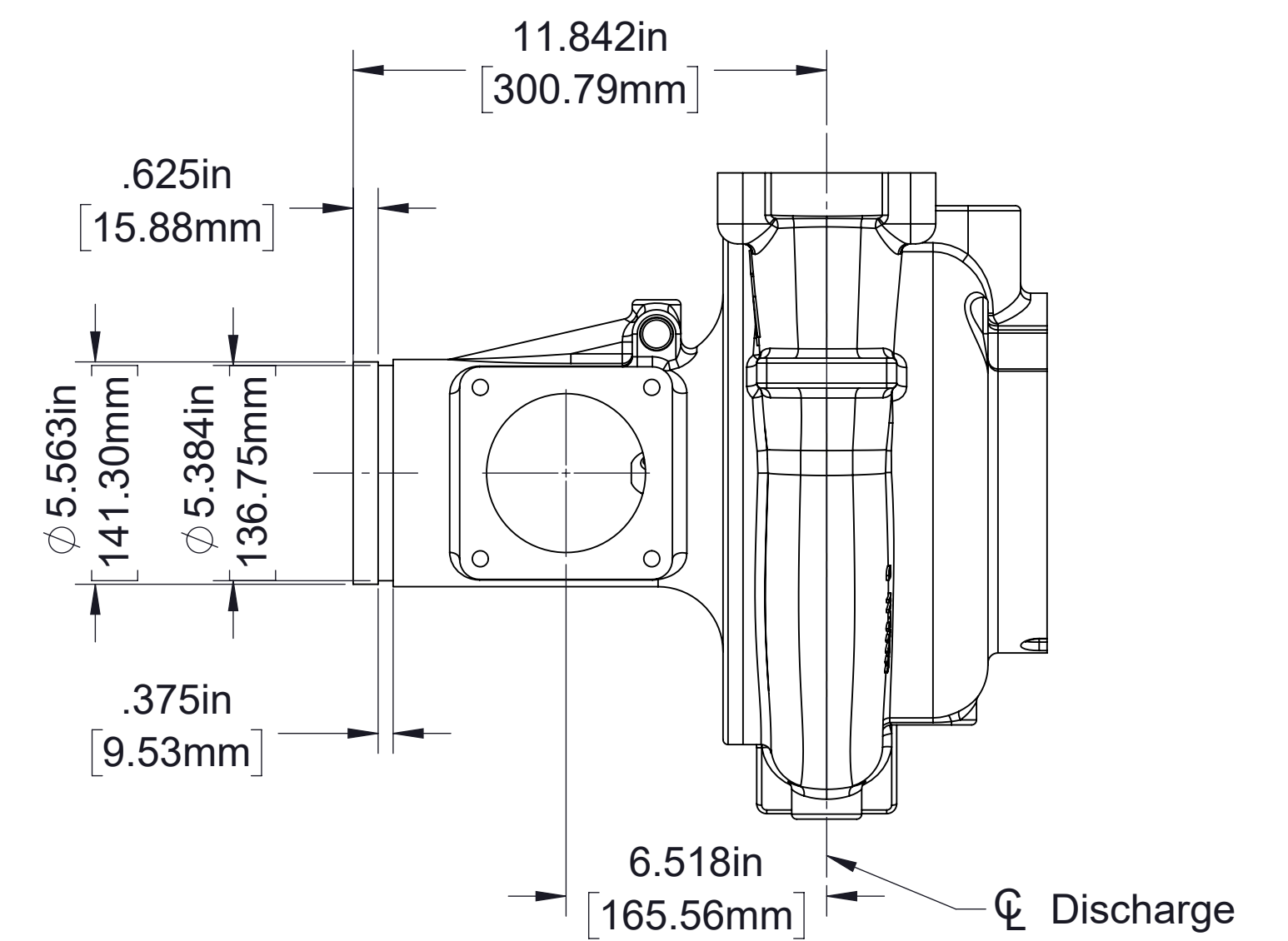

5 in Grooved (Victaulic)

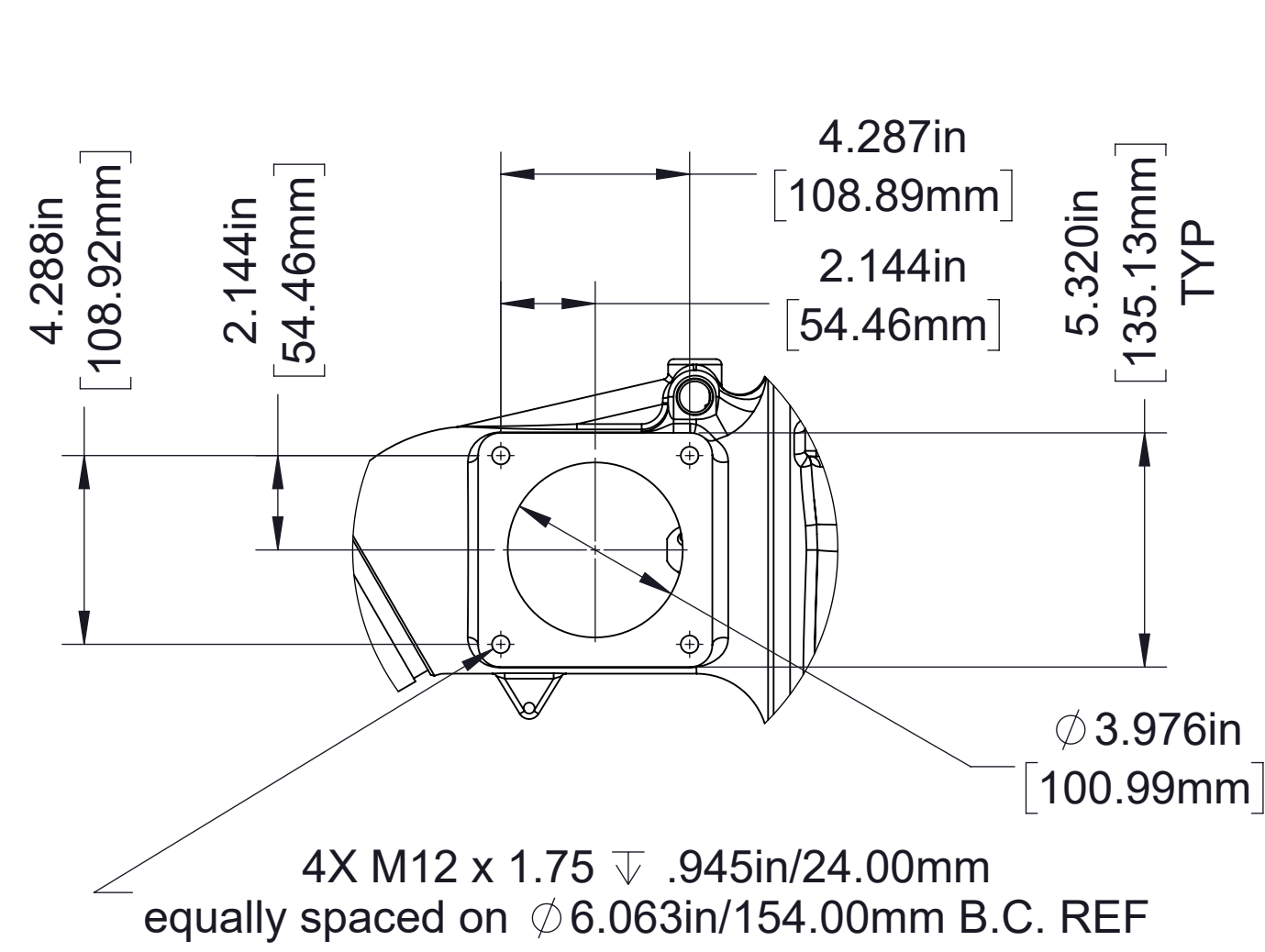

Detail A
101 mm 4-Bolt
 See page 12 for auxiliary fittings which may be mounted on these pads

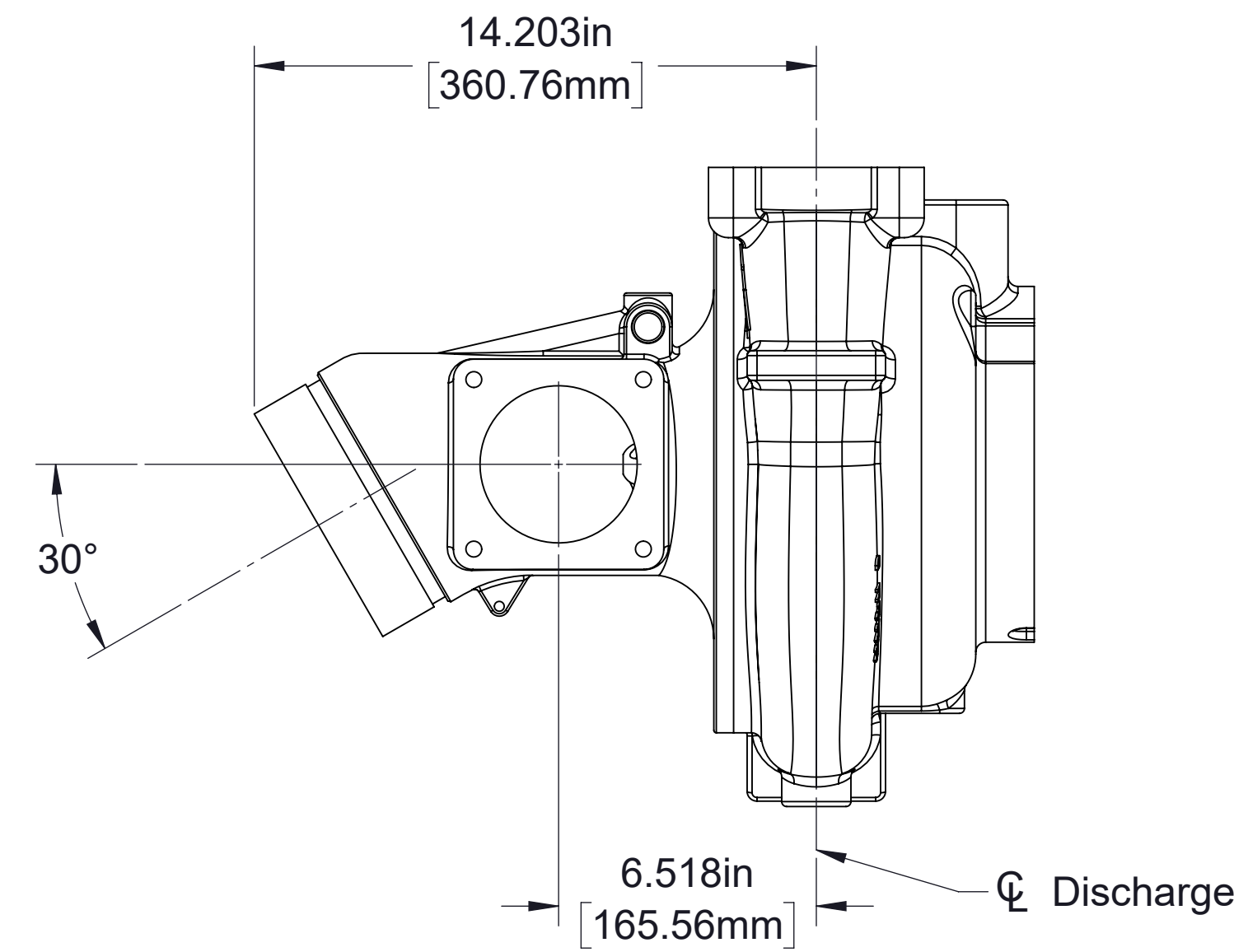

6 in BSP Thread

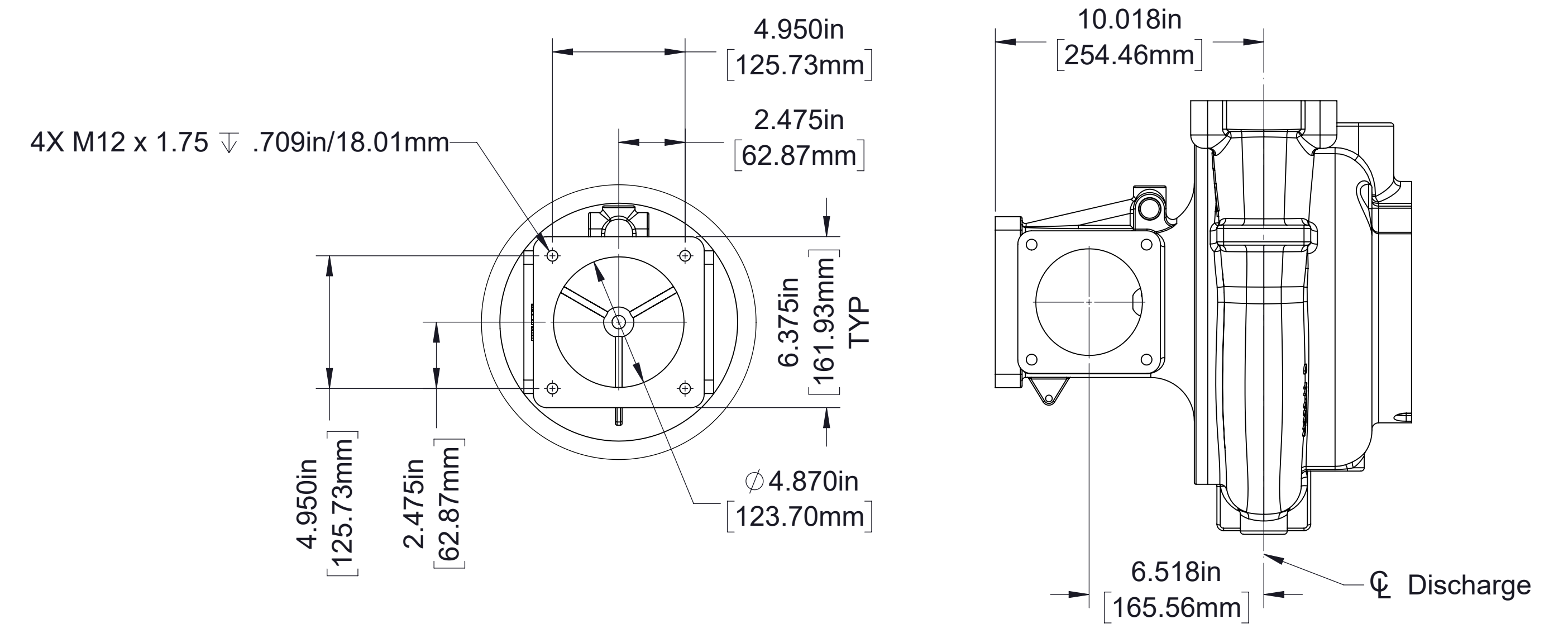

4-Bolt Flange

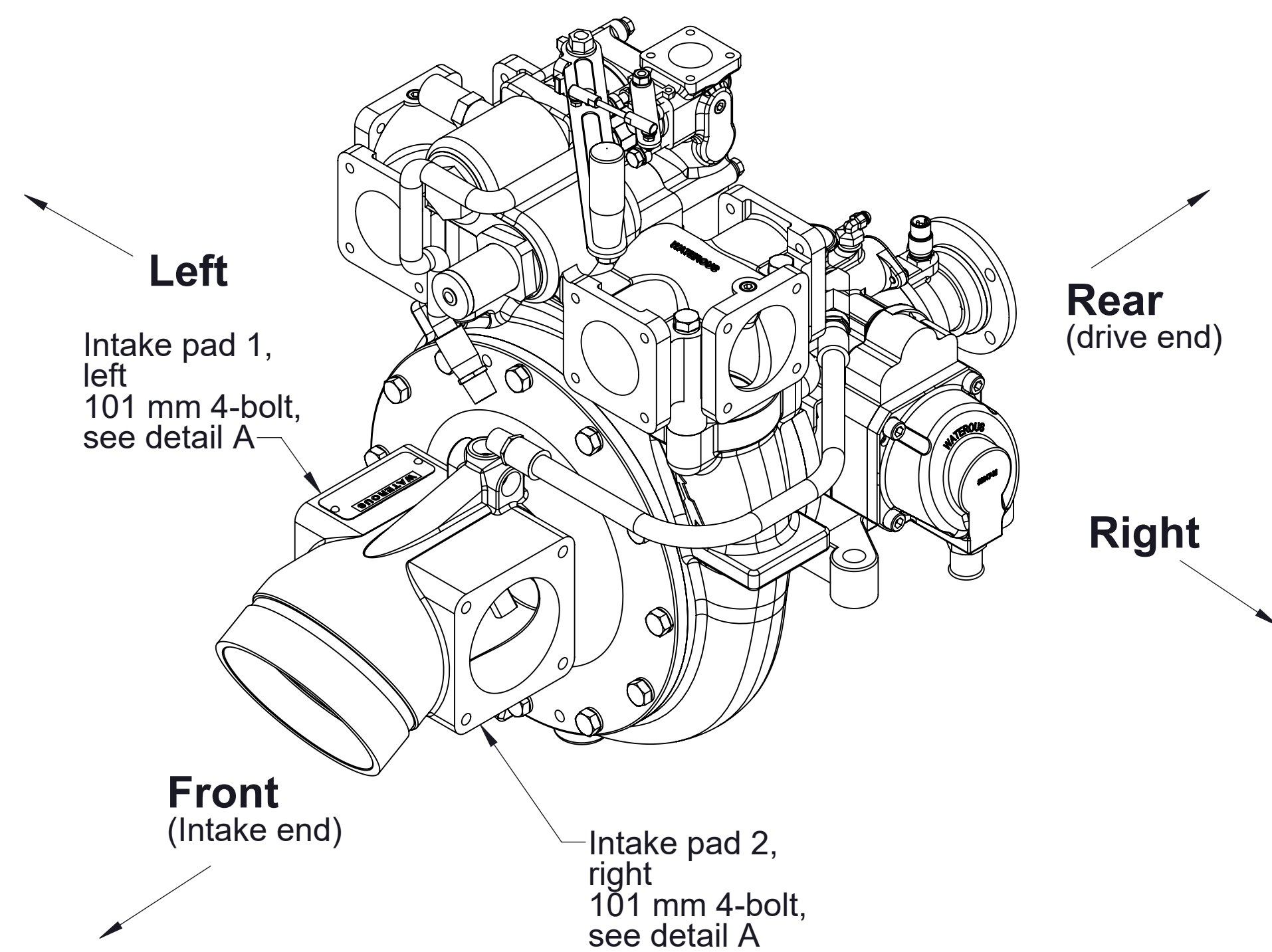

Available Intake Connections

(Continued on next page)

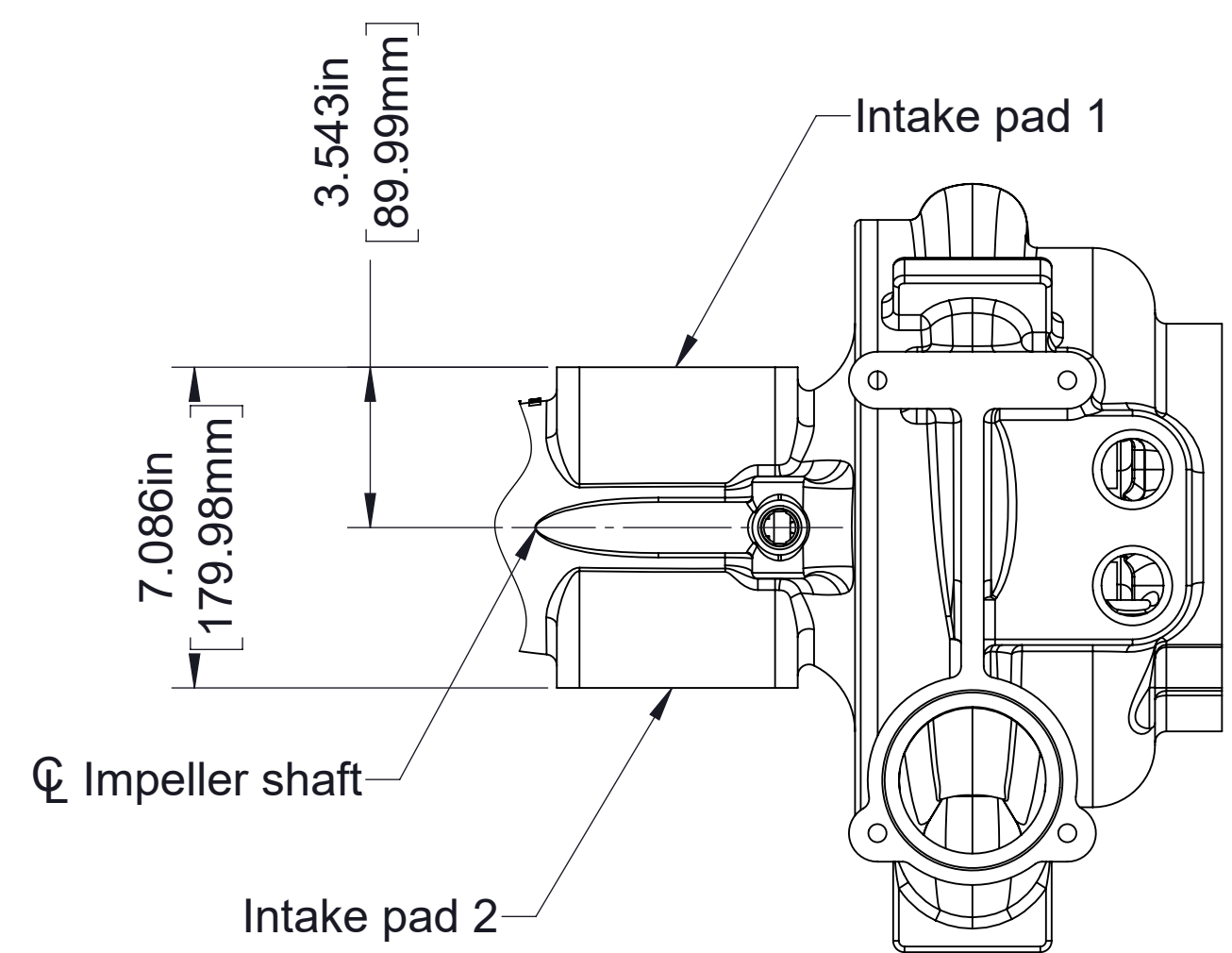

**(Top view of Pump and Intake)
Dimensions typical for all HL series
intake connections**

See detail A for dimensions of pad 1 and 2

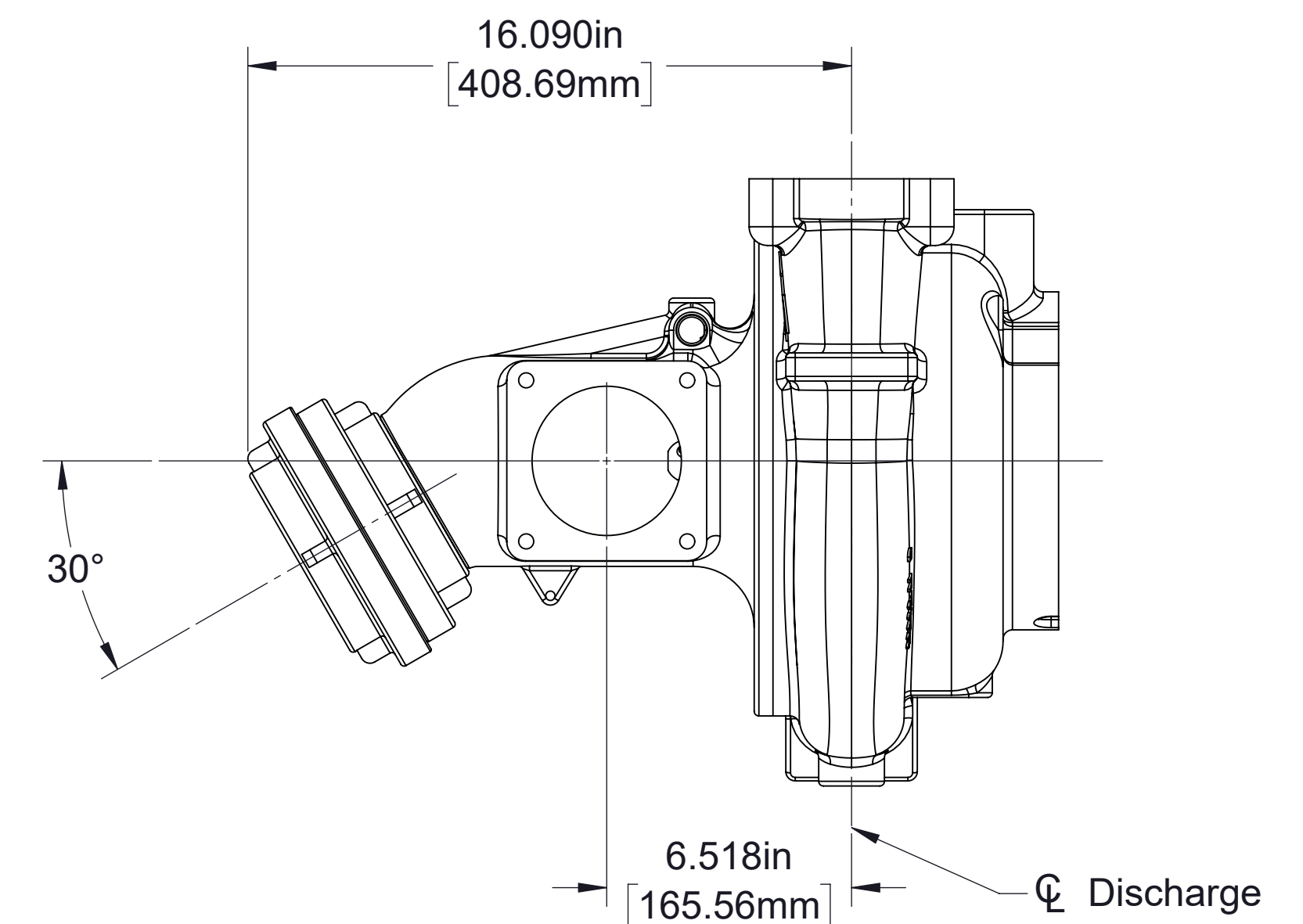
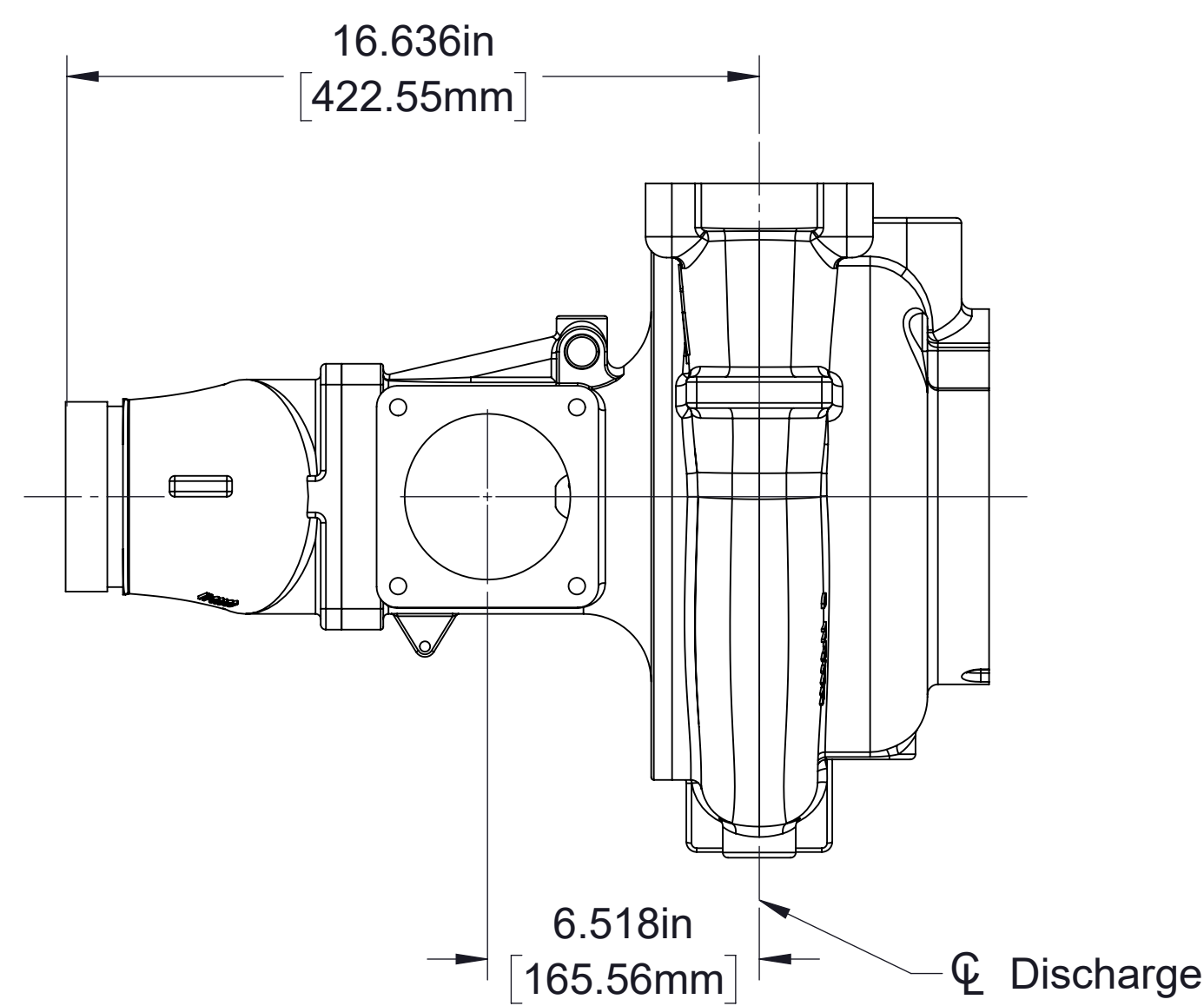
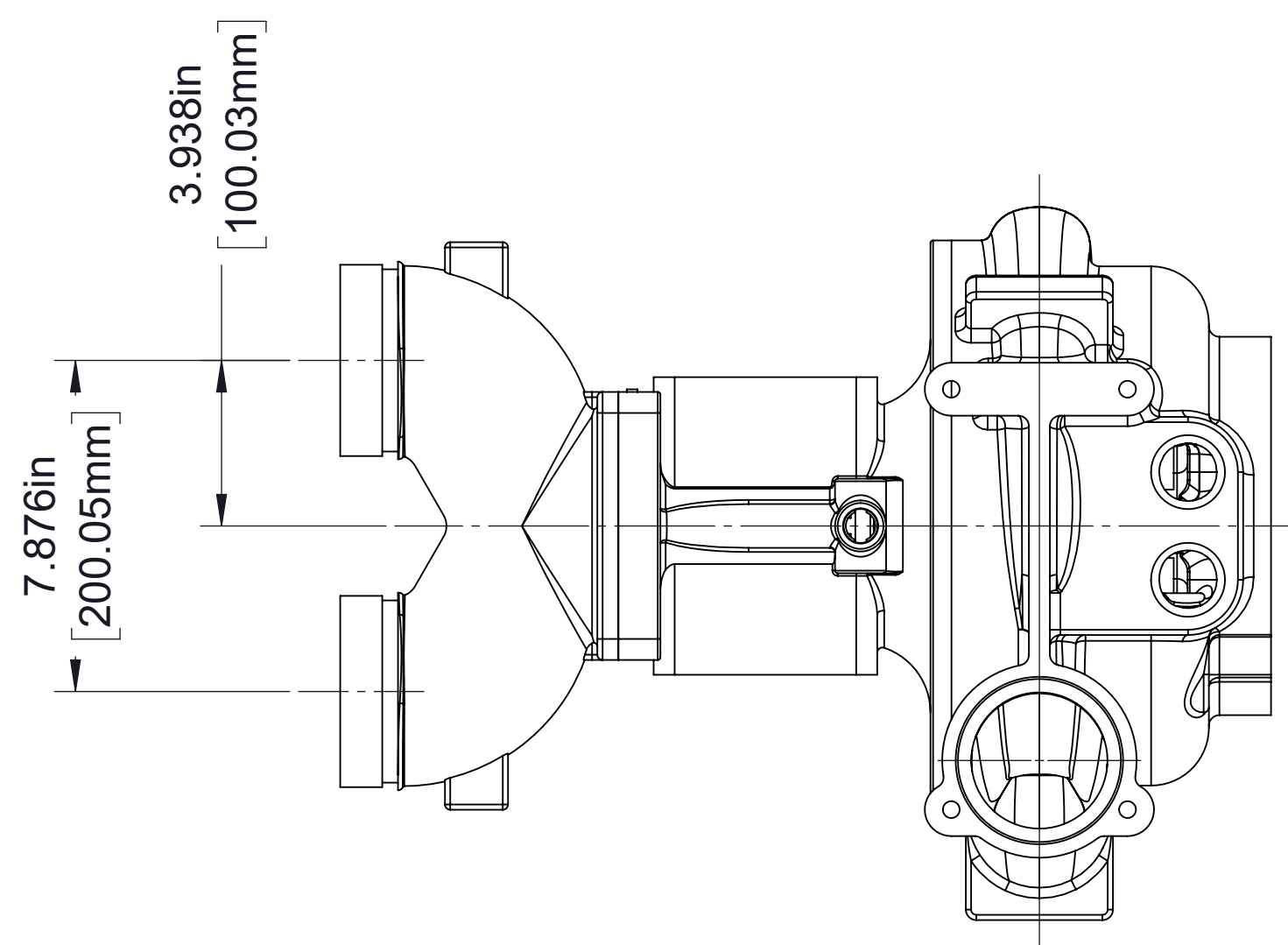

110 mm Storz Adapter on 4 in BSP Thread

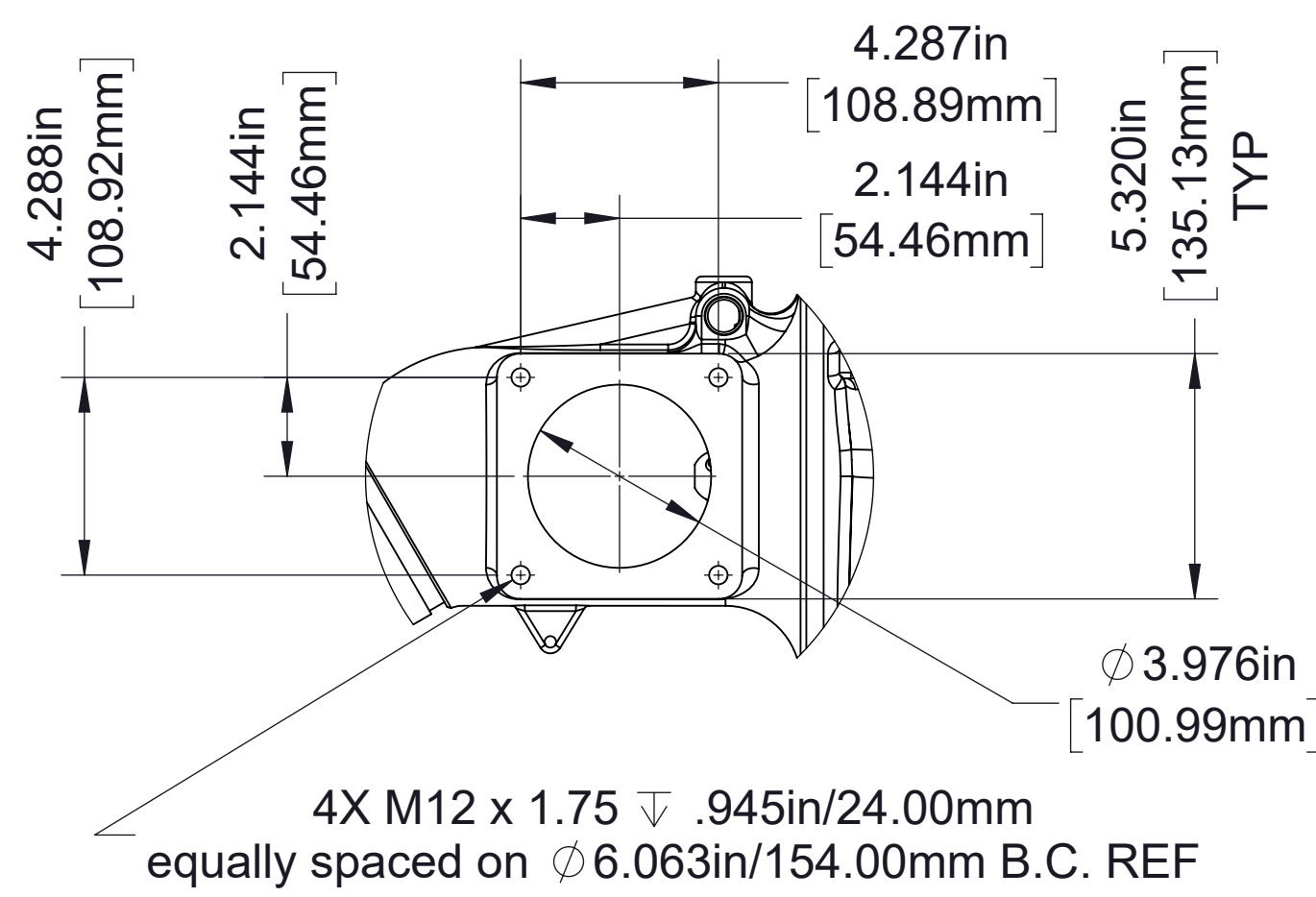

4X M12 x 1.75 ∇ .945in/24.00mm
equally spaced on ϕ 6.063in/154.00mm B.C. REF

**Detail A
101 mm 4-Bolt**

See page 12 for auxiliary fittings which
may be mounted on these pads

Dual 4 in BSP Thread

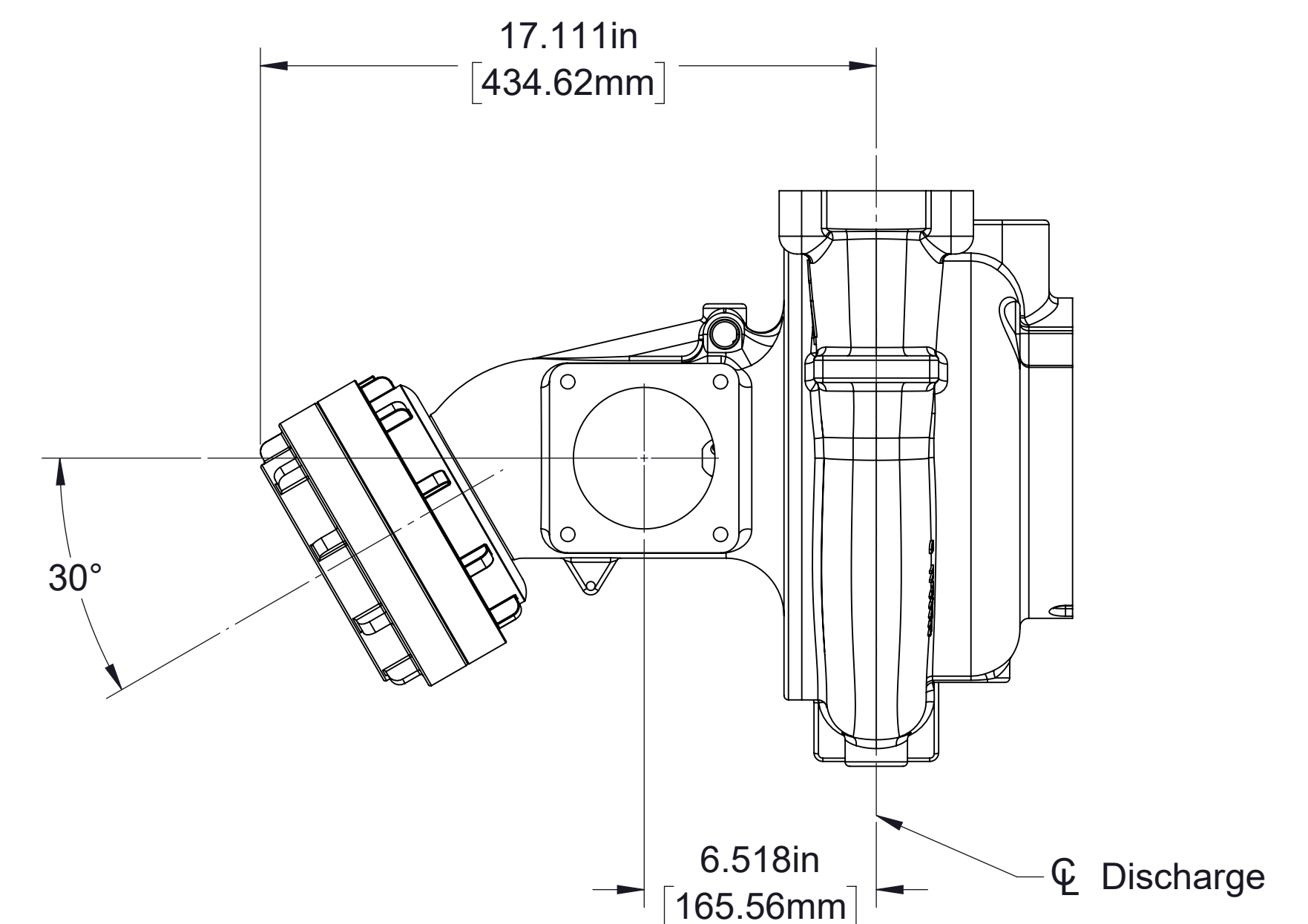

150 mm Storz Adapter on 4 in BSP Thread

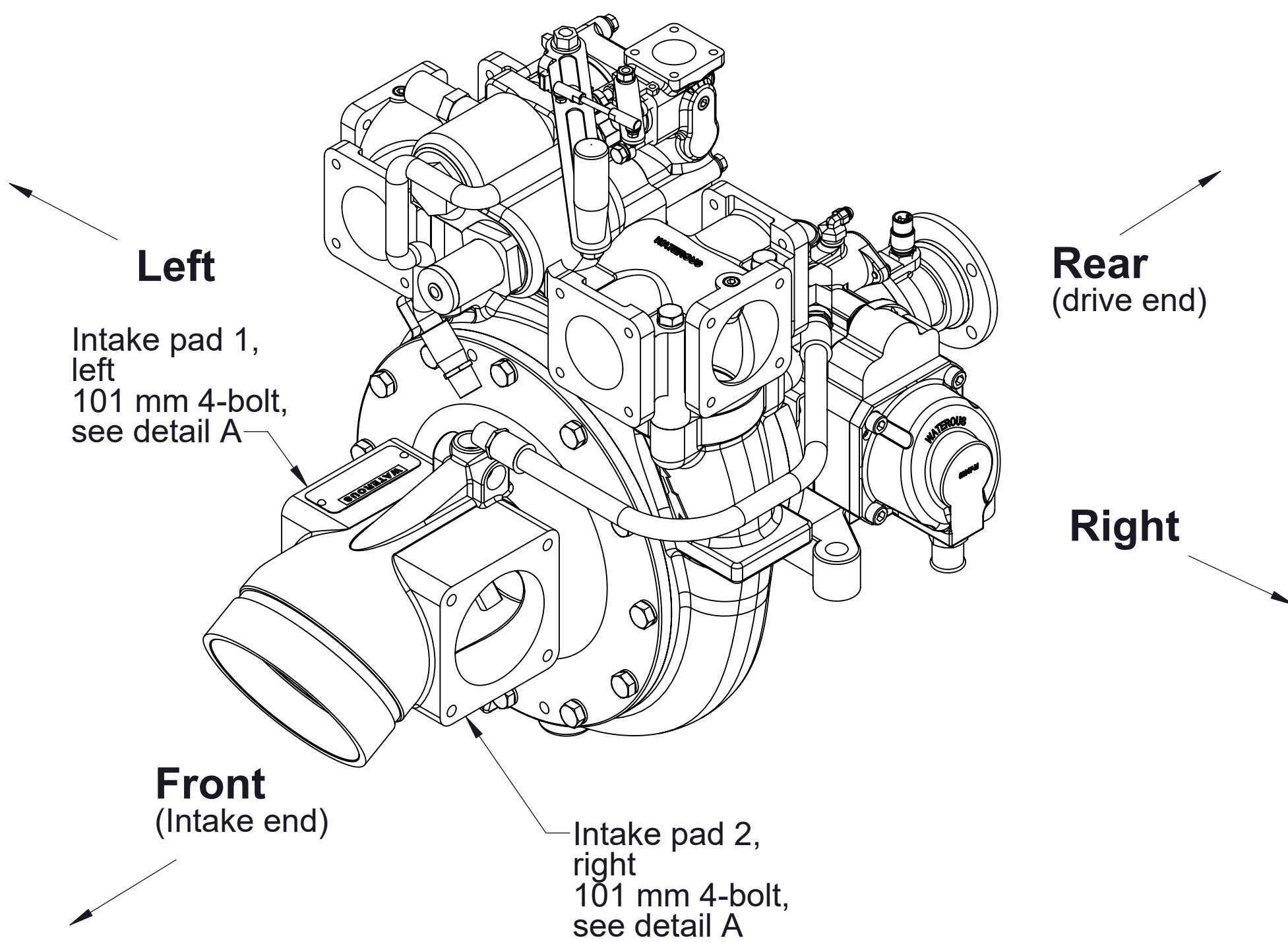

Available Intake Connections

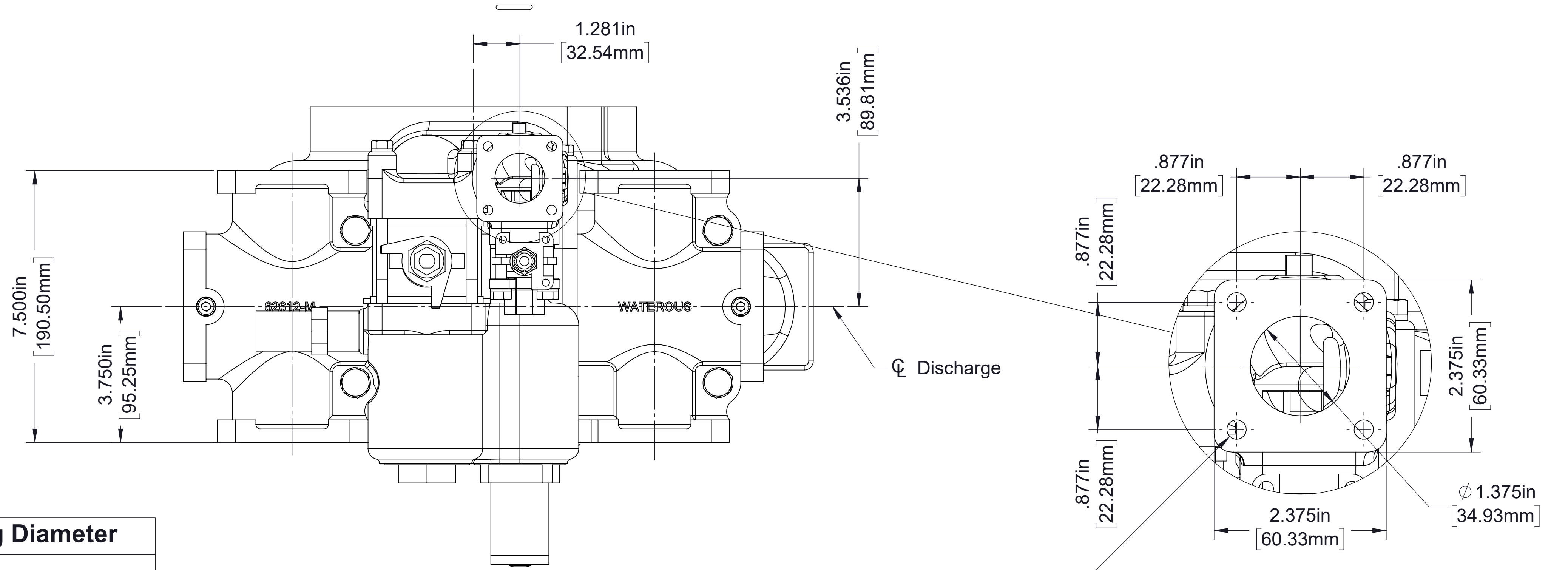
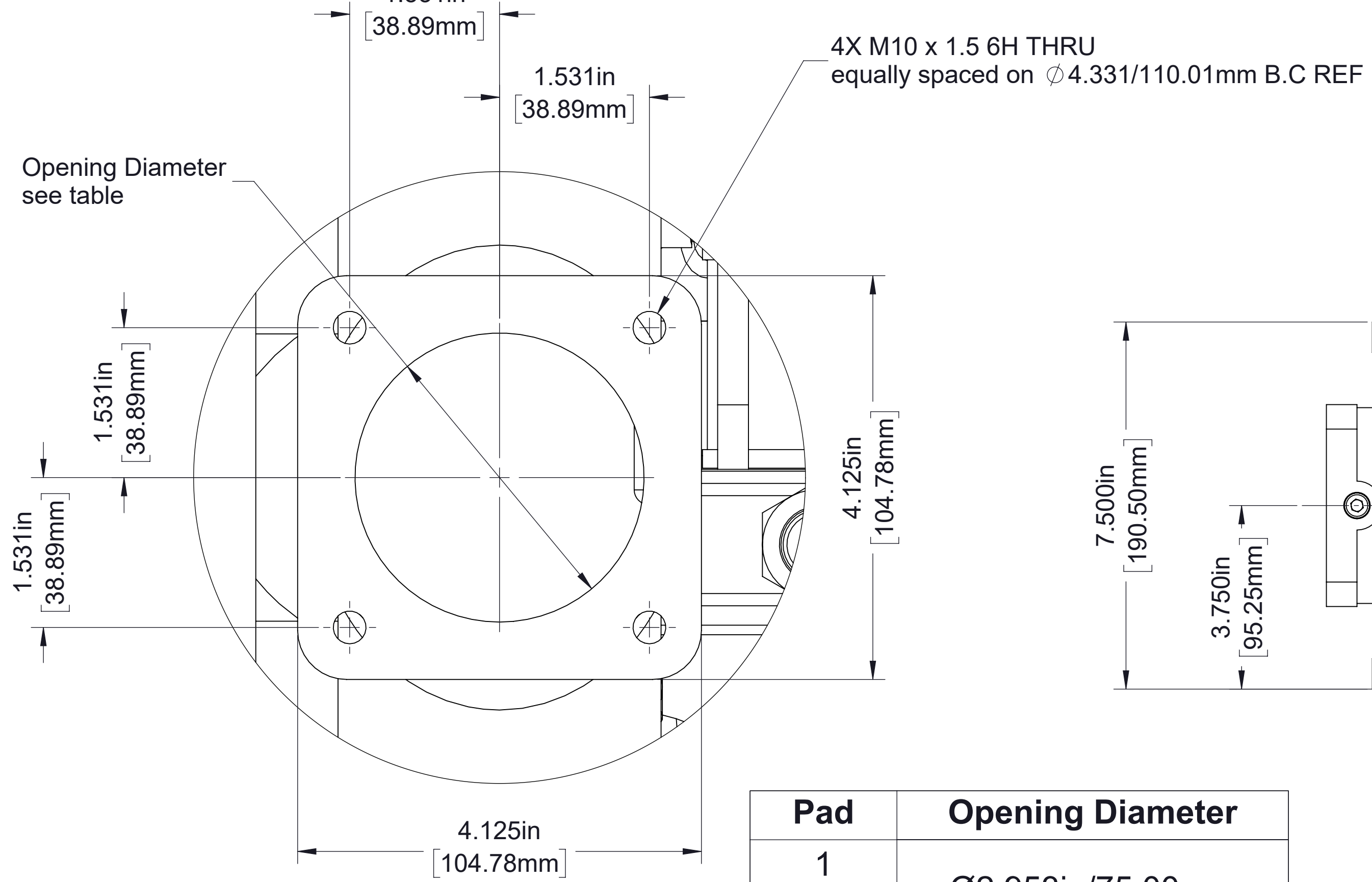

Pad	Opening Diameter
1	\varnothing 2.953in/75.00mm
2	
3	\varnothing 2.550in/64.77mm
4	
5	
6	

Detail B
65 mm 4-Bolt
See page 11 for auxiliary fittings which may be mounted on these pads

4X M8 x 1.25 ∇ .630in/16mm MIN

Detail C
35 mm 4-Bolt
See page 11 for auxiliary fittings which may be mounted on this pad

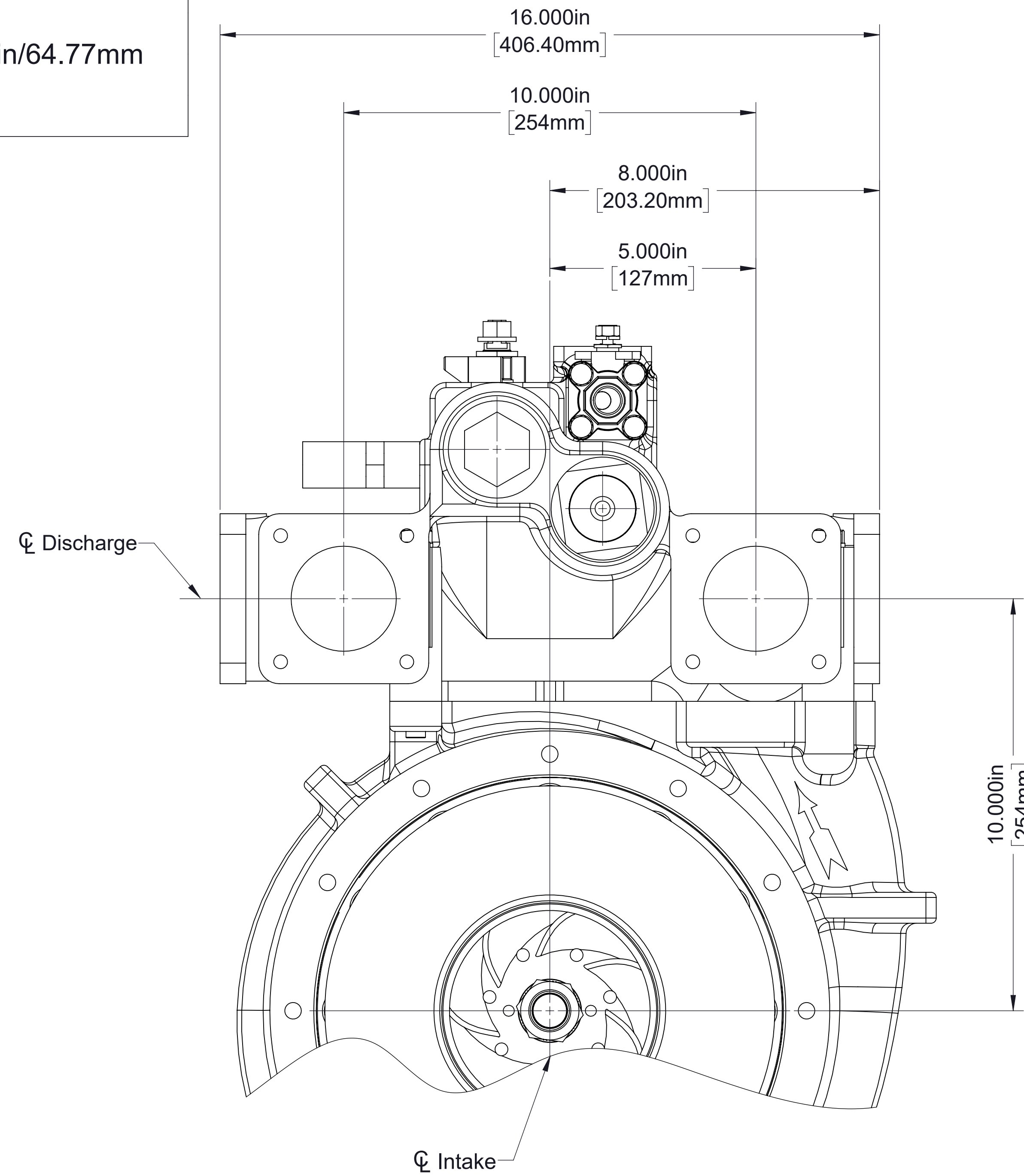
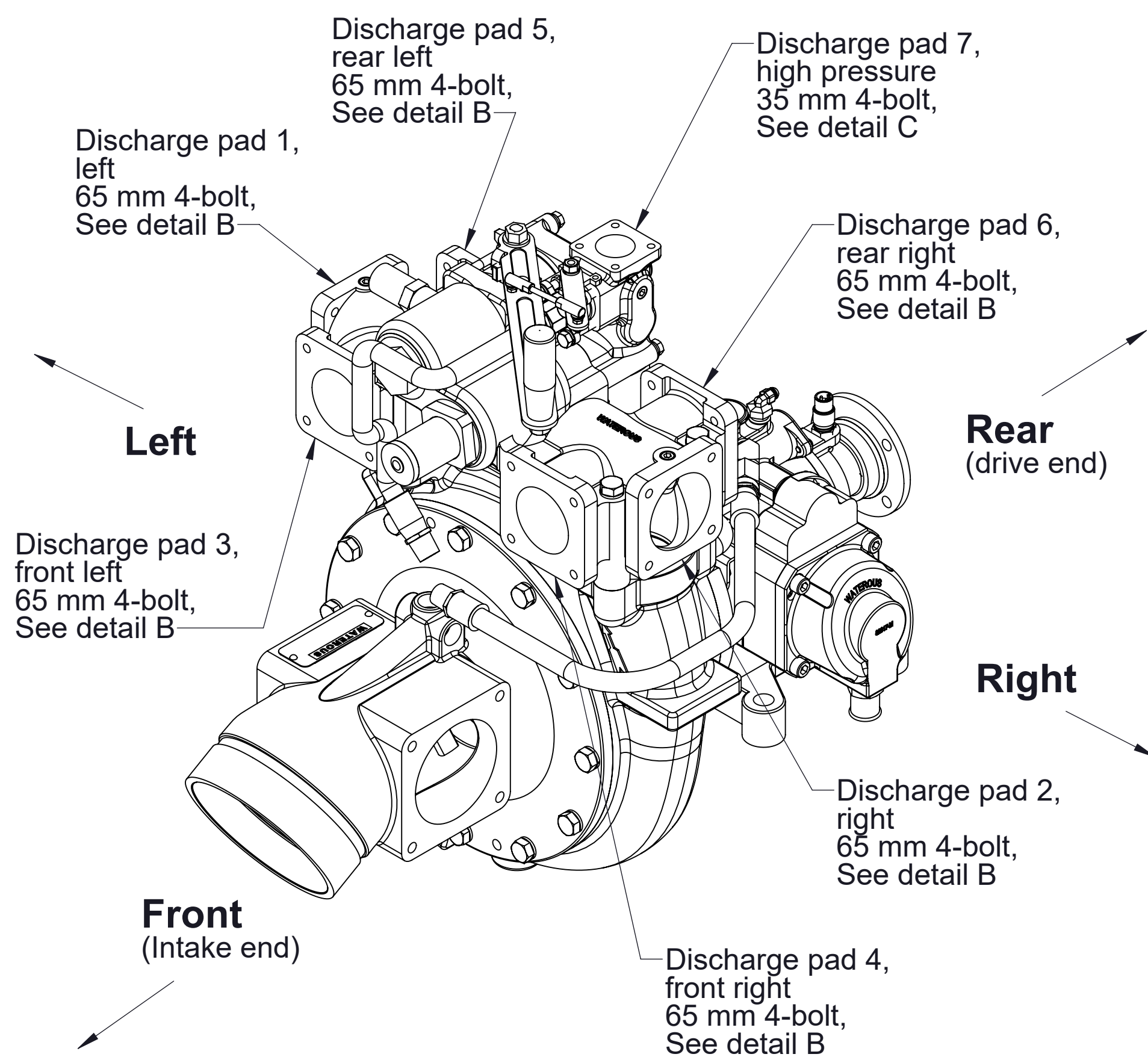

Discharge Manifold

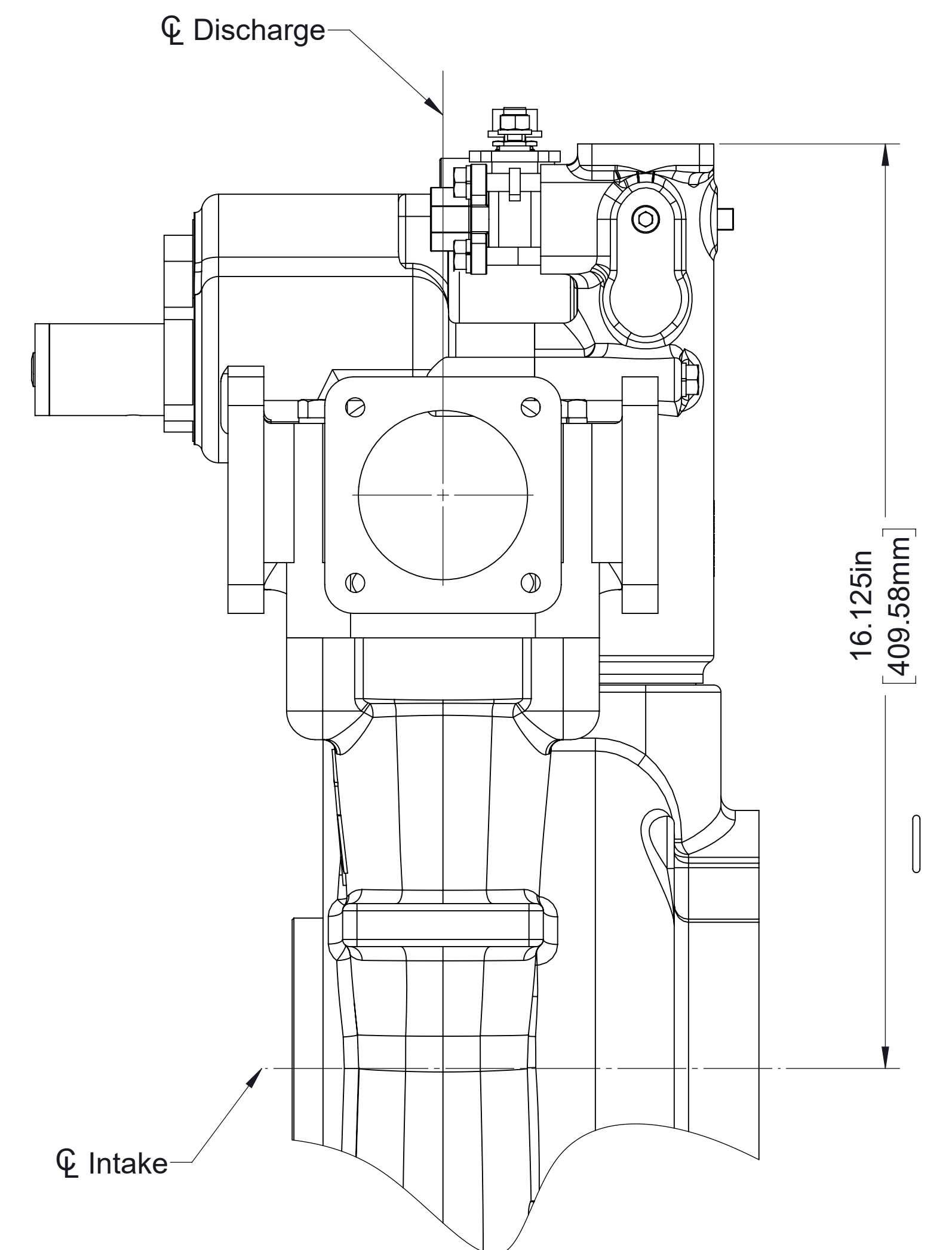

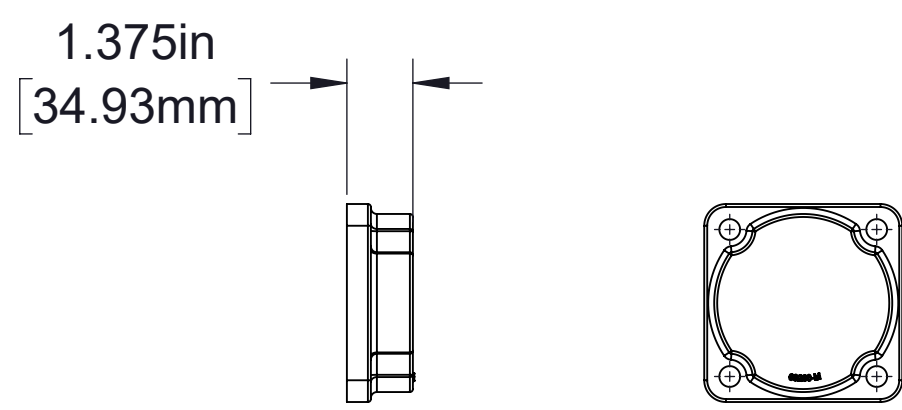

Blind Flange

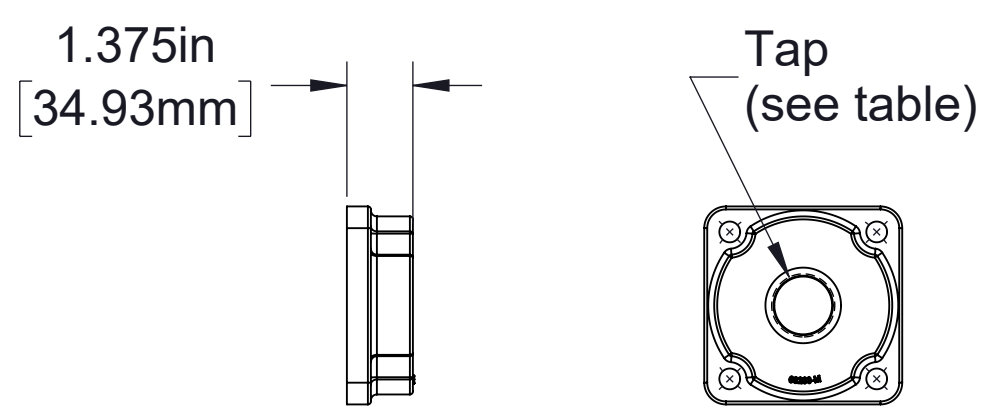

Tap Options
1 in BSP
2-1/2 in BSP
1 in NPT

Tapped Flanges

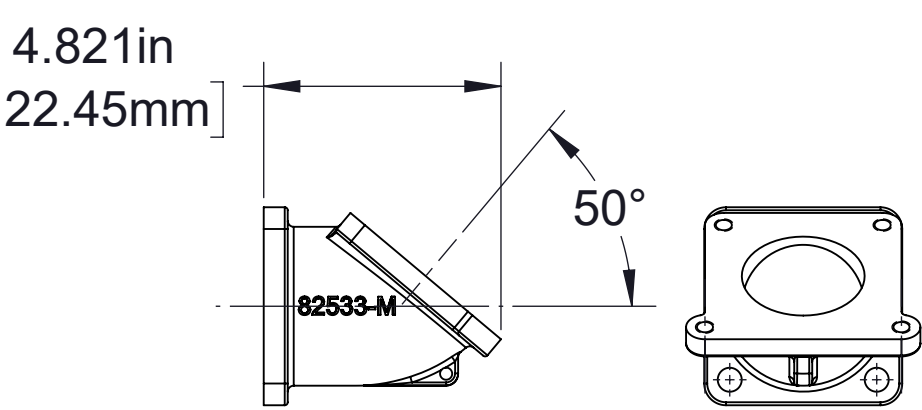

30° Elbow

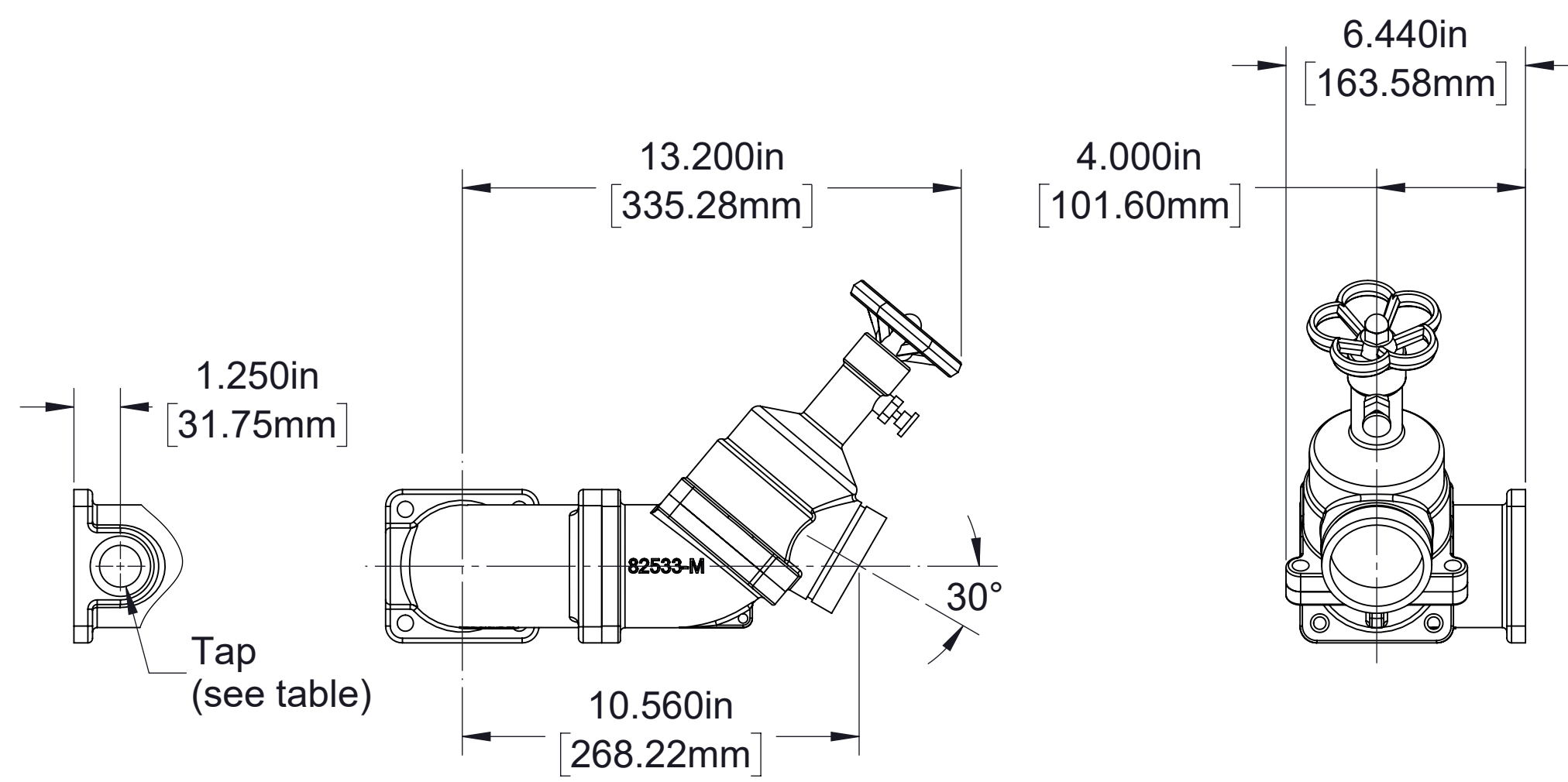

Tap Options
1 in BSP (open)
1 in BSP (plugged)
1 in NPT (open)
1 in NPT (plugged)

2-1/2 in BSP Valve with 30° and 90° Elbows

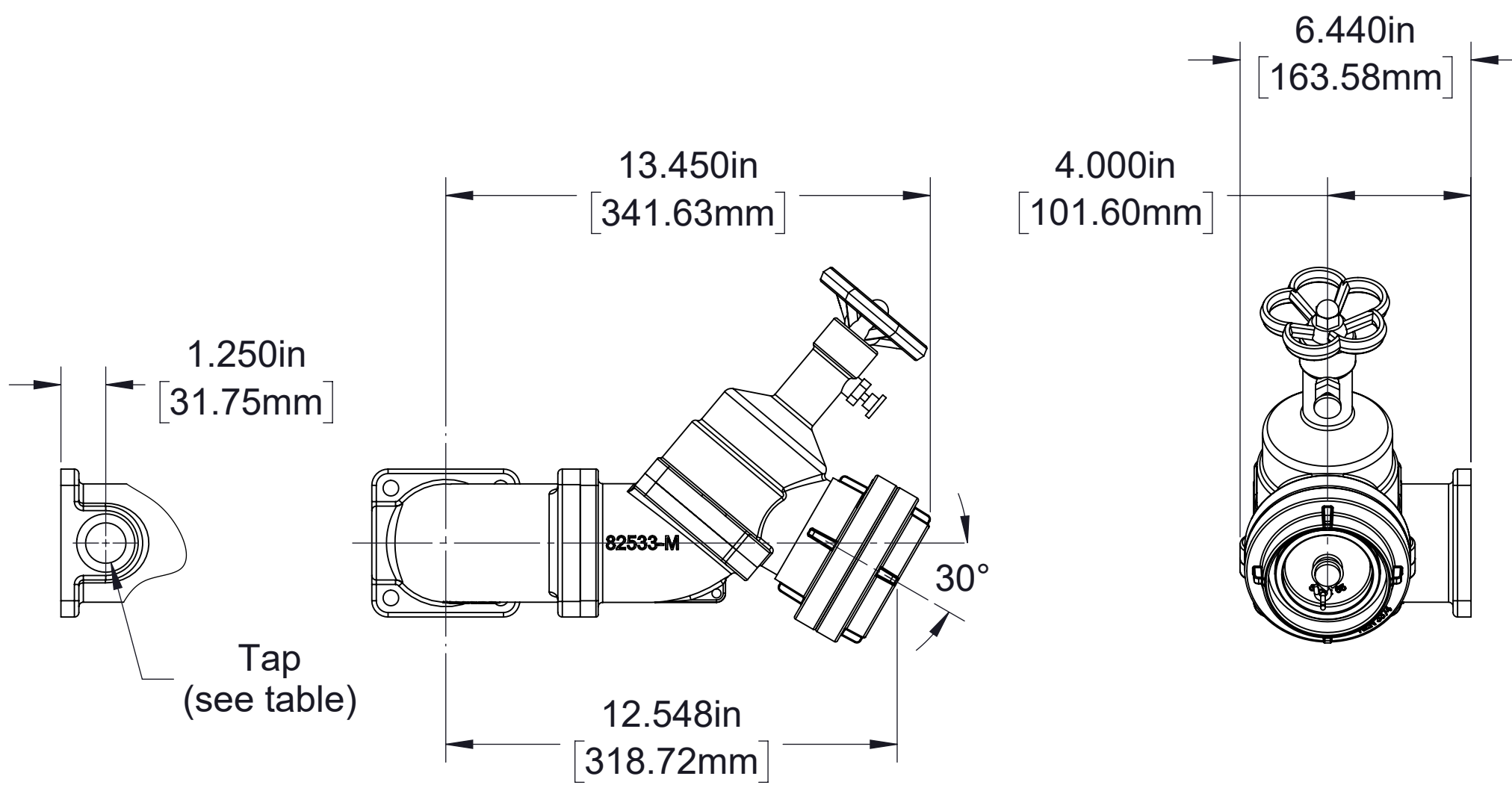

Tap Options
1 in BSP (open)
1 in BSP (plugged)
1 in NPT (open)
1 in NPT (plugged)

65 mm Storz Valve with 30° and 90° Elbows

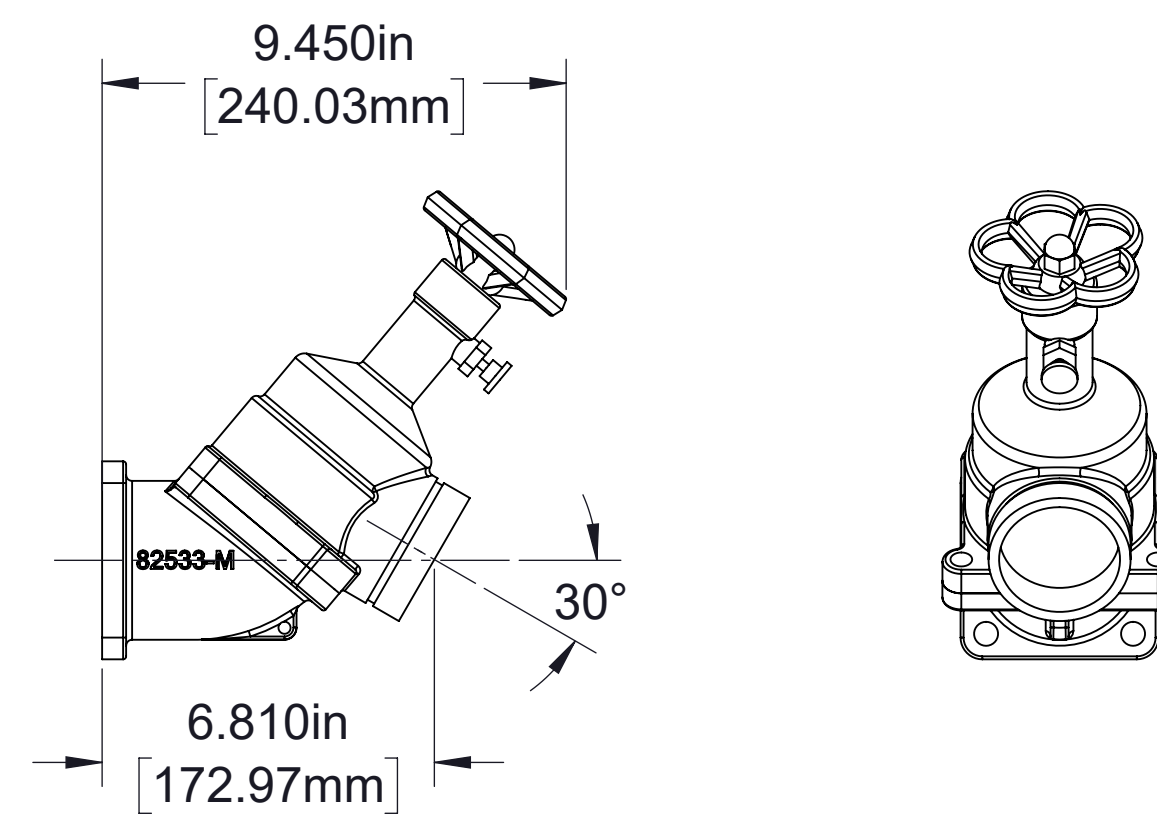

2-1/2 in BSP Valve with 30° Elbow

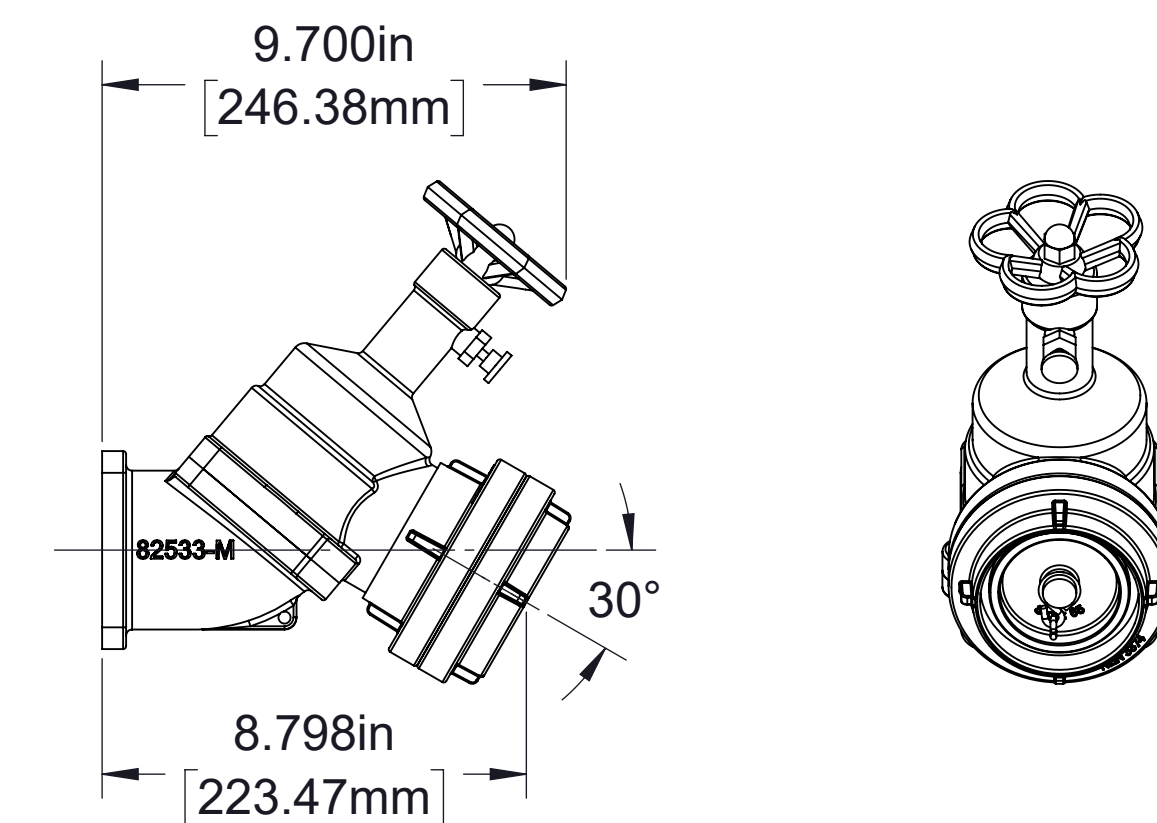

65 mm Storz Valve with 30° Elbow

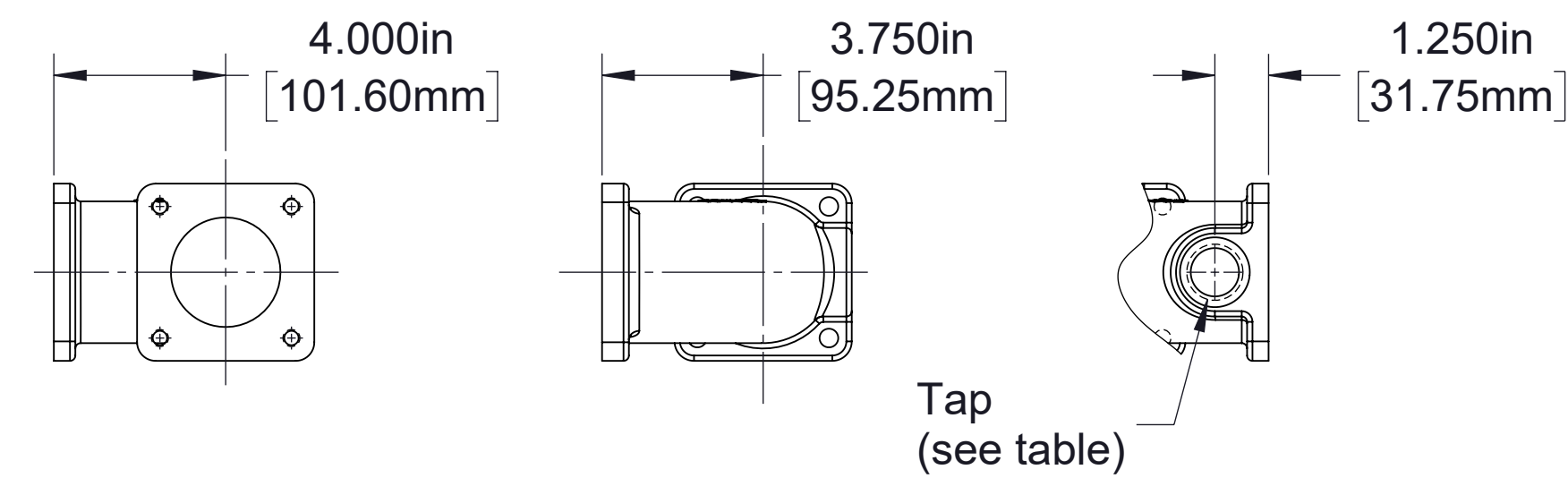

Tap Options
1 in BSP (open)
1 in BSP (plugged)
1 in NPT (open)
1 in NPT (plugged)

90° Elbows

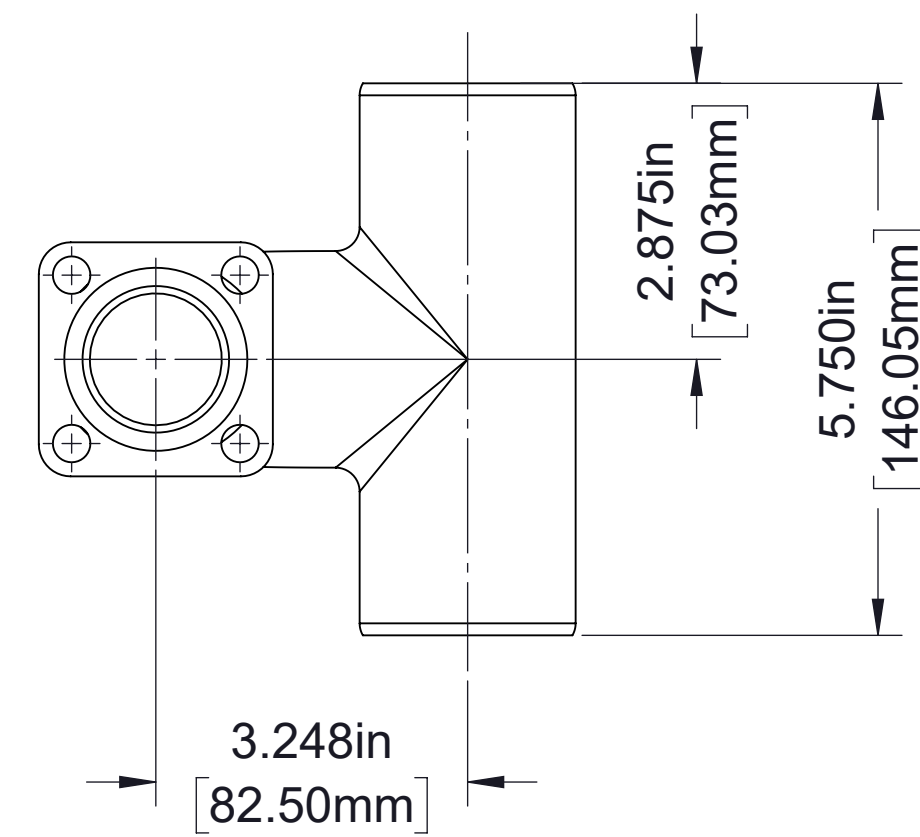
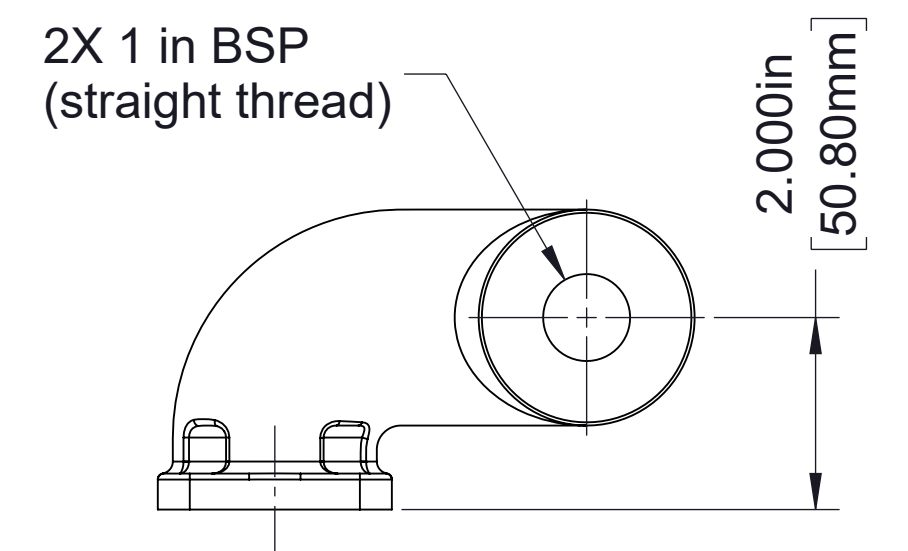

Manifold

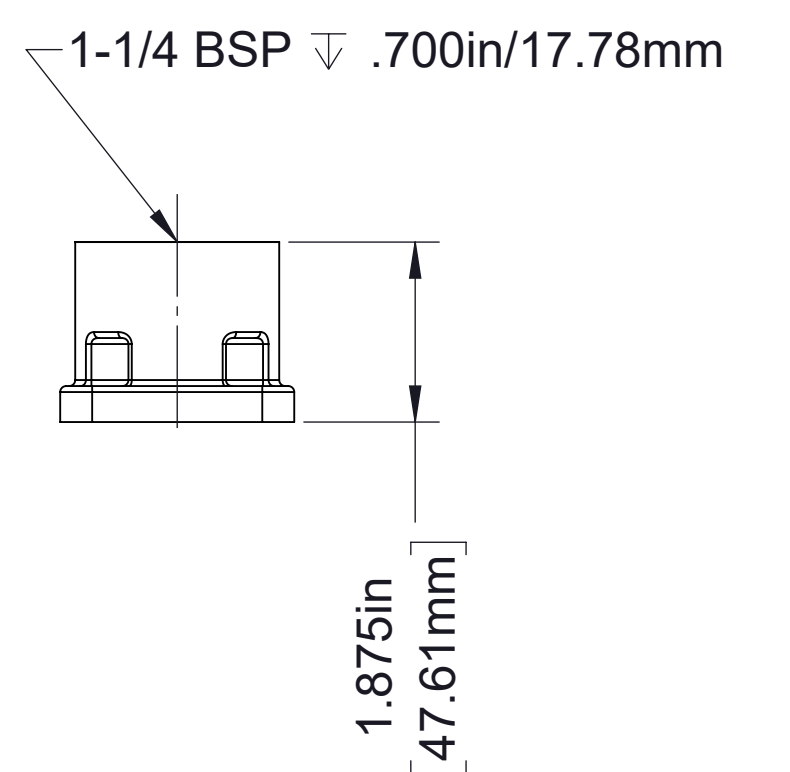

Tapped Flange

35 mm 4-Bolt

65 mm 4-Bolt

Auxiliary Fittings

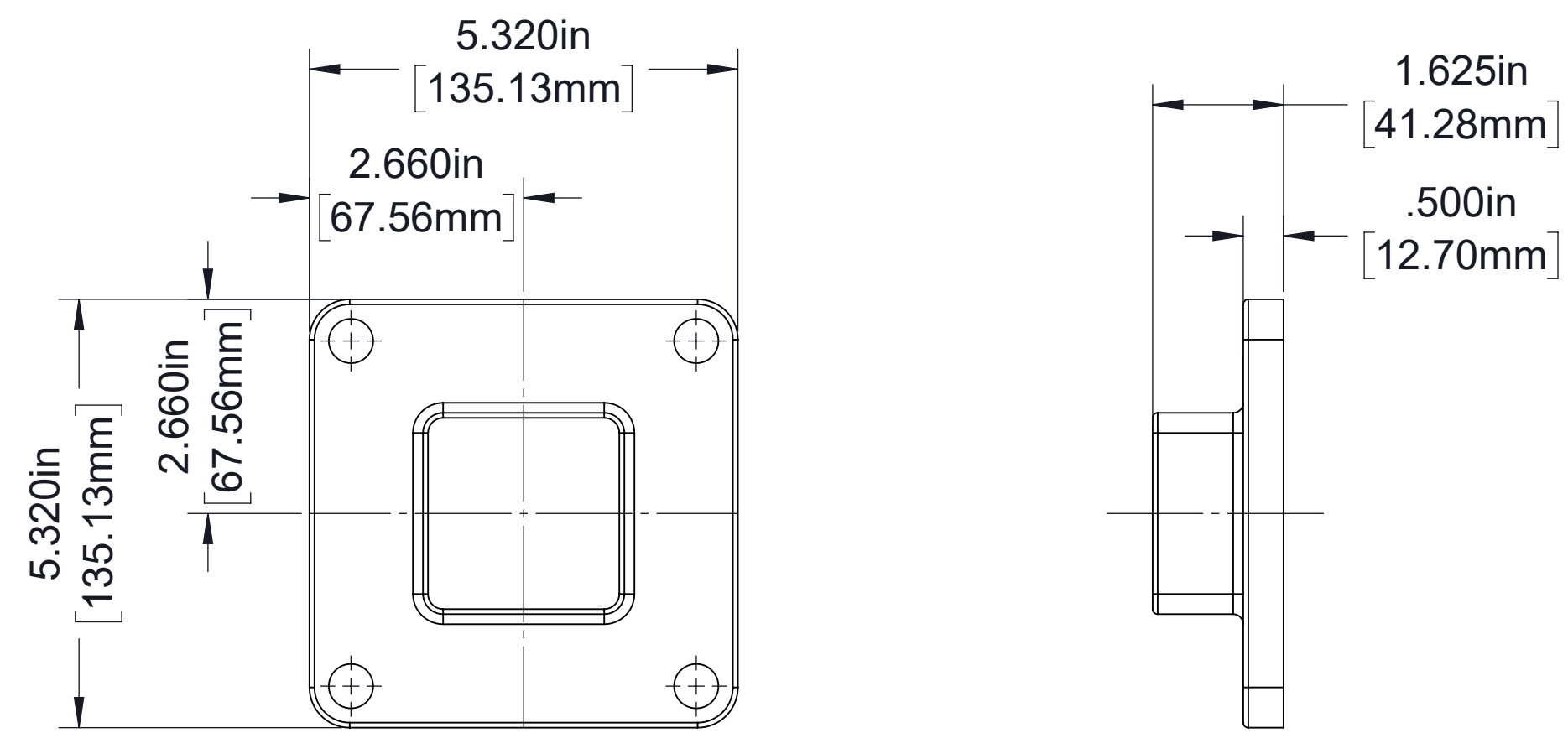

Blind Flange

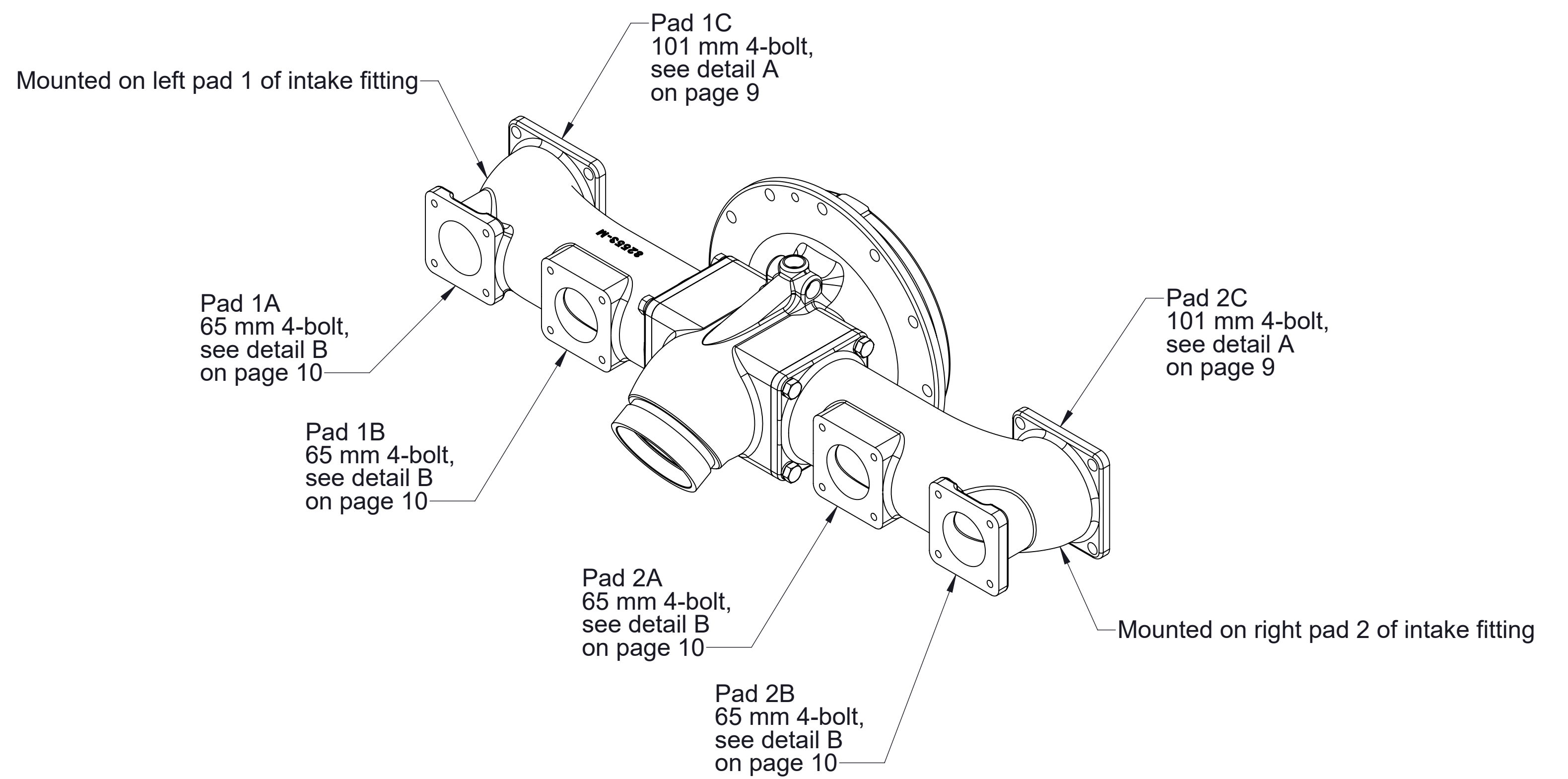
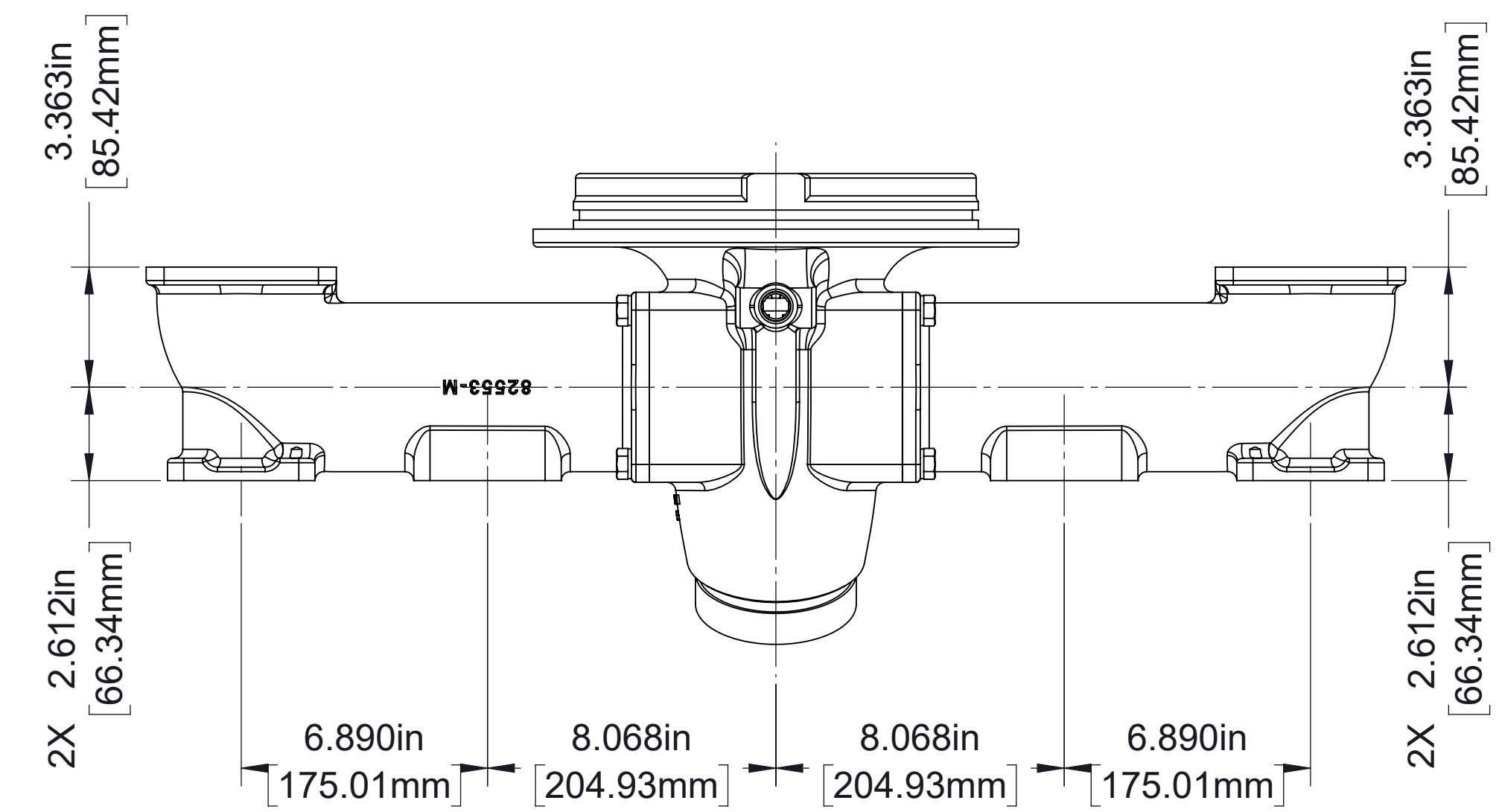

Optional Intake Manifold

(For pad details, see detail A on page 8 or 9 and detail B on page 10)

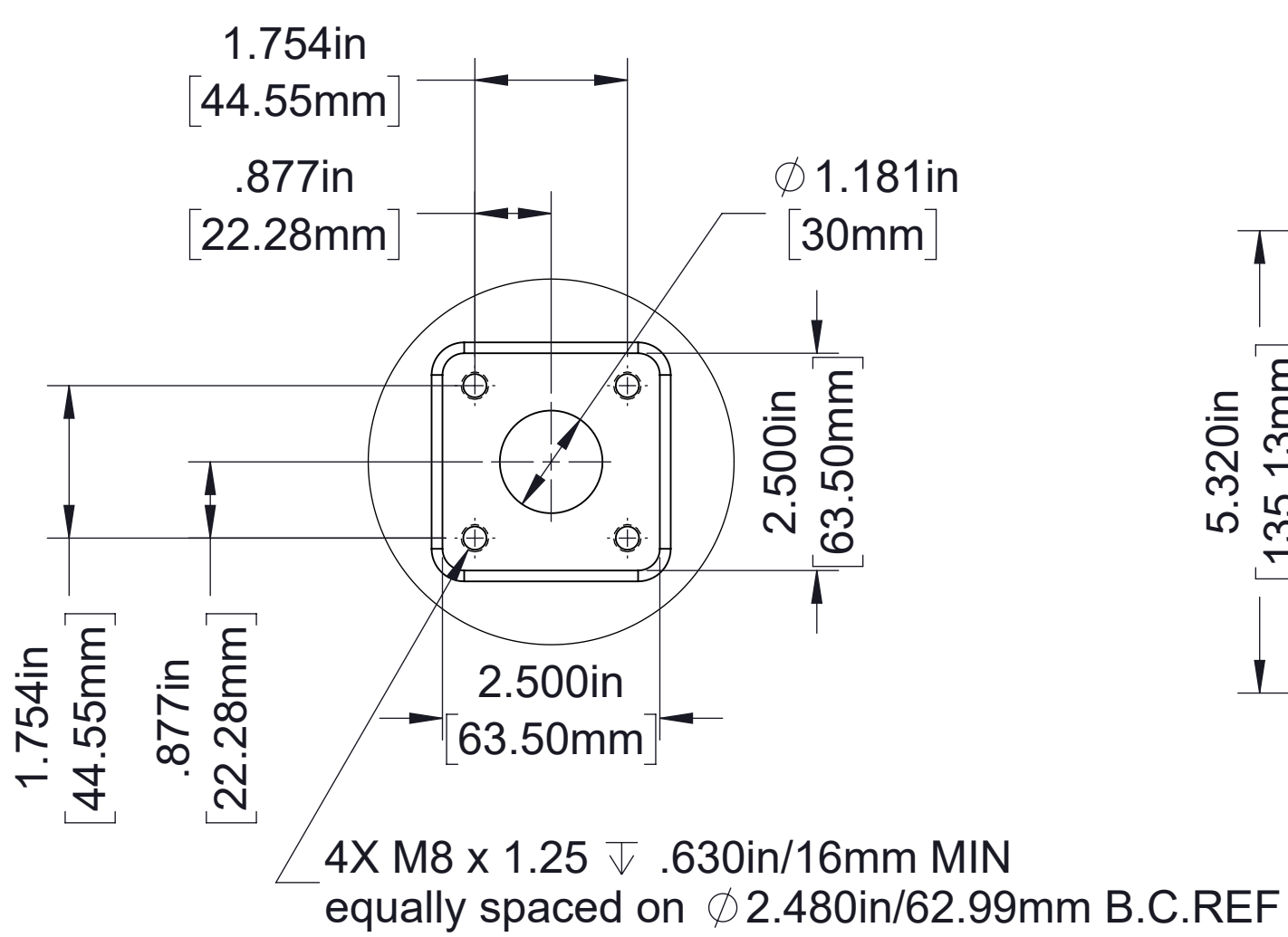

Foam Flange Detail

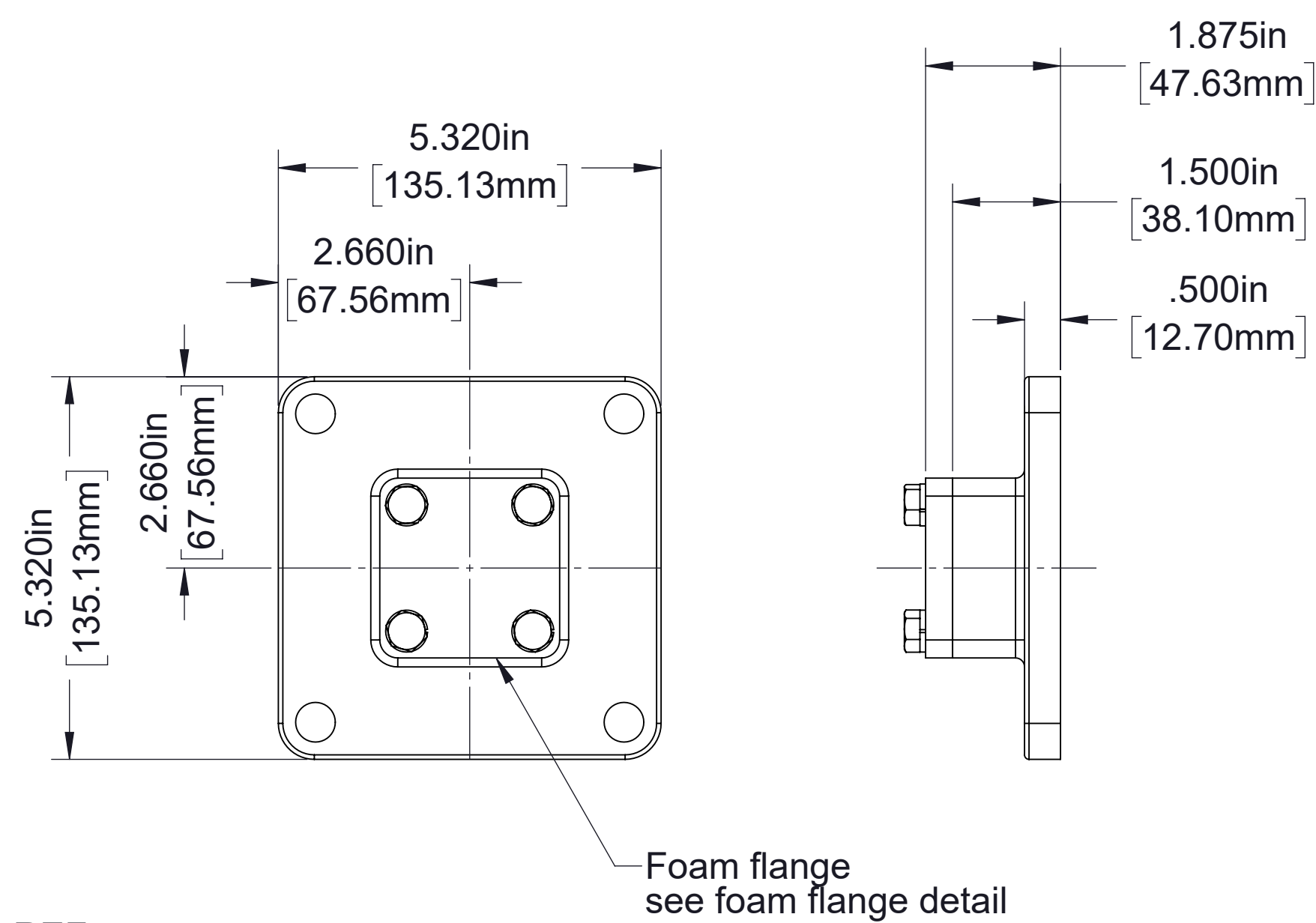

Foam Flange with Blind Foam Pad

**101 mm 4-Bolt
Auxiliary Fittings**

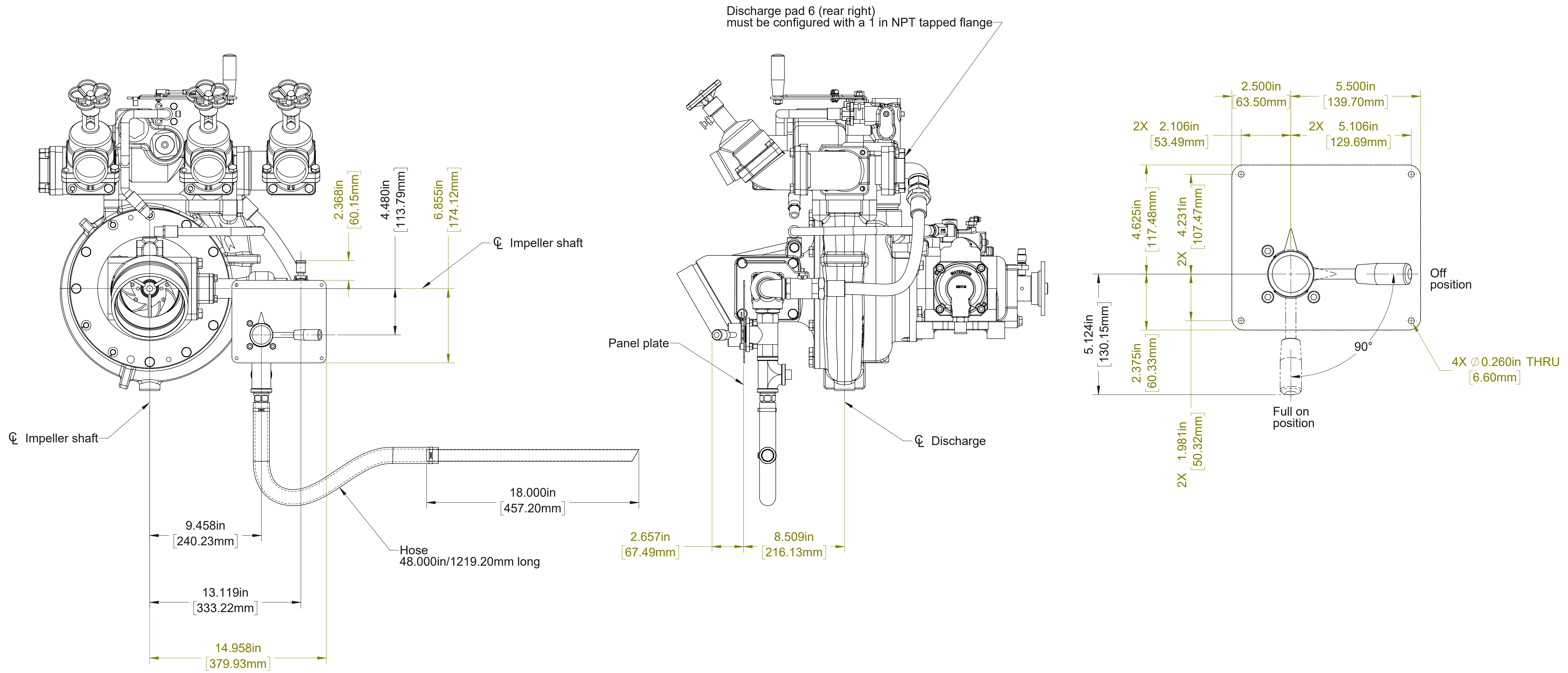

Optional RTP Foam System
 Mounted on pump at factory

Available Panel Configurations

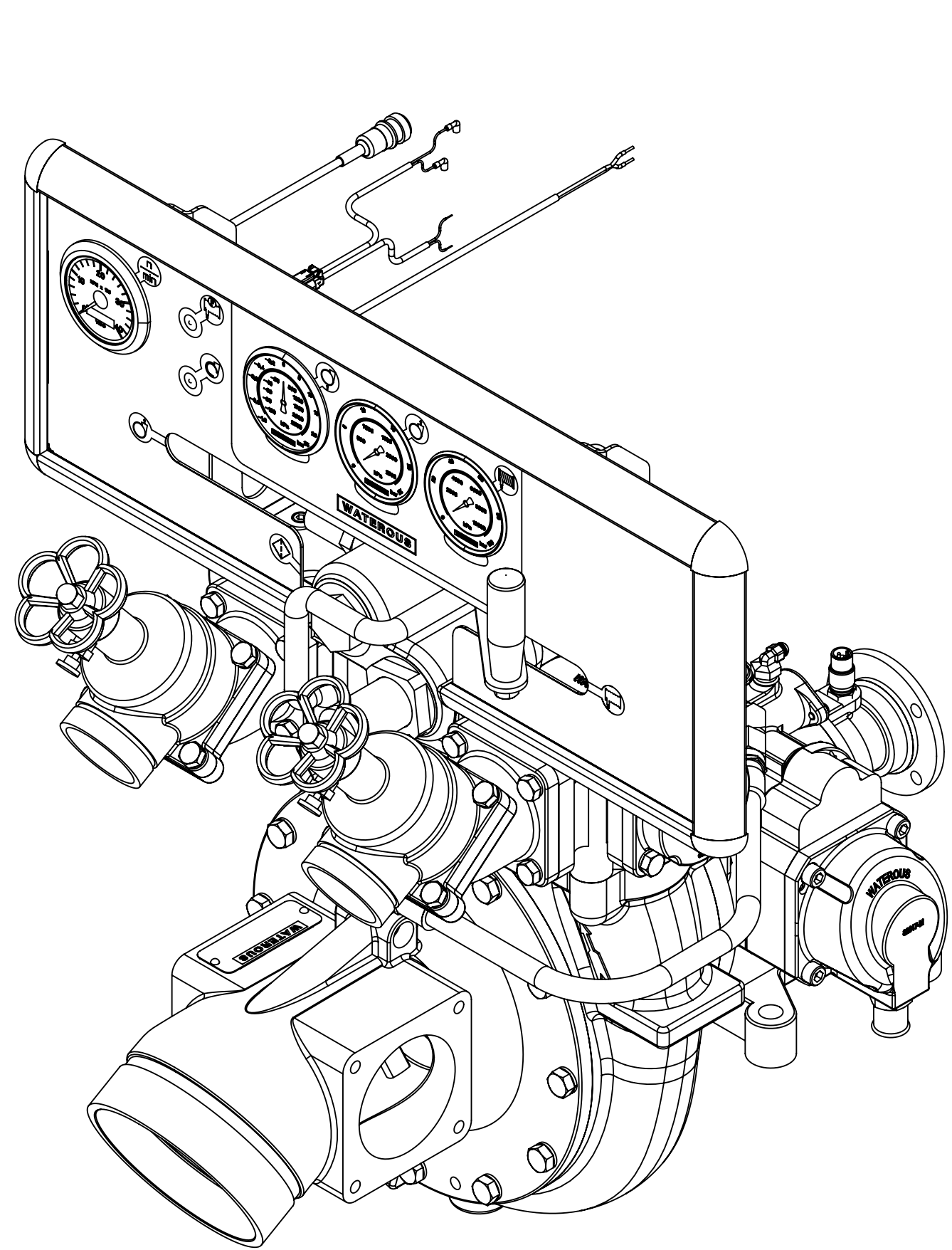

Without Tank Level Monitors

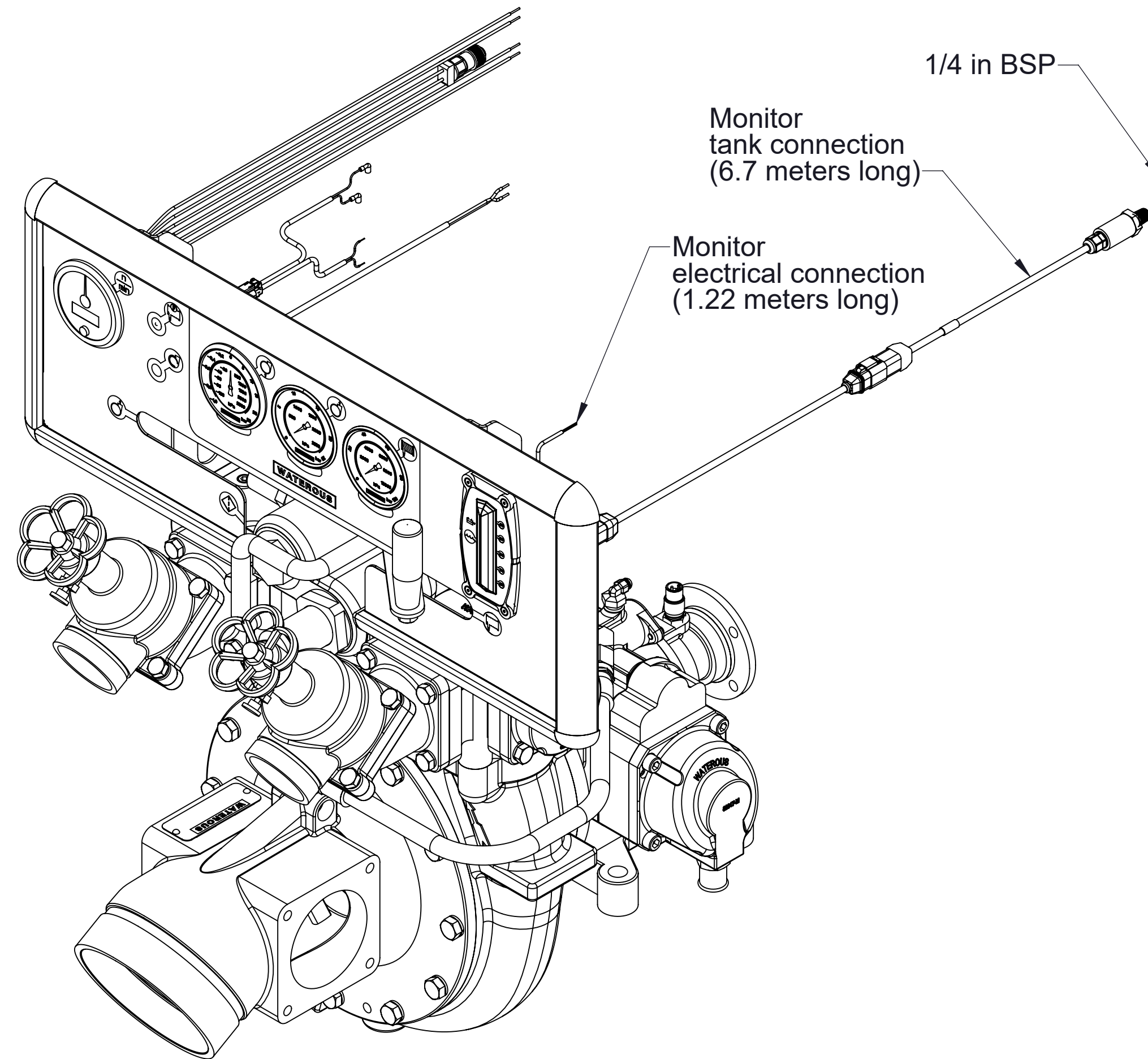

With Water Tank Level Monitor Only

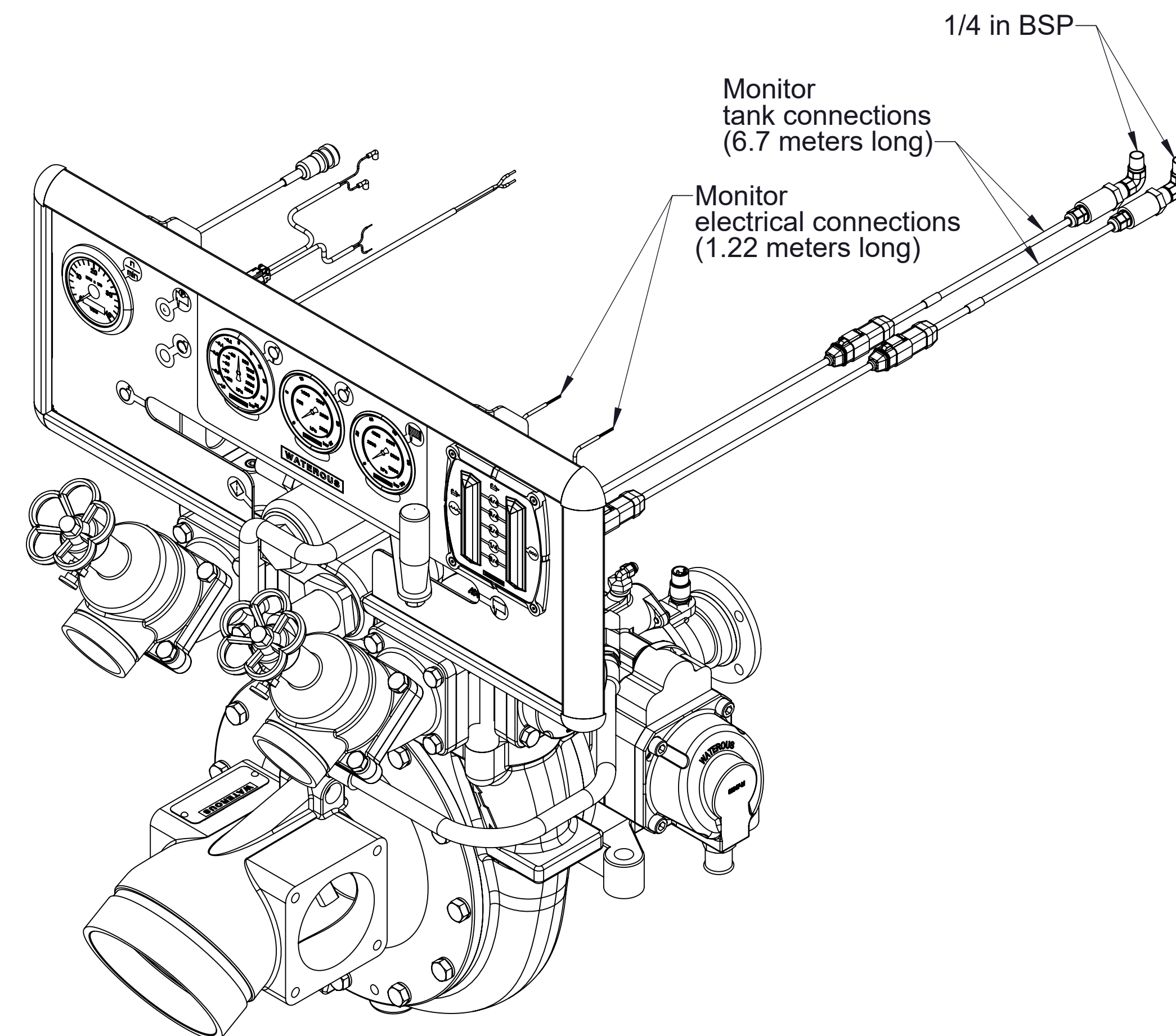

With Water Tank and Foam Tank Level Monitors

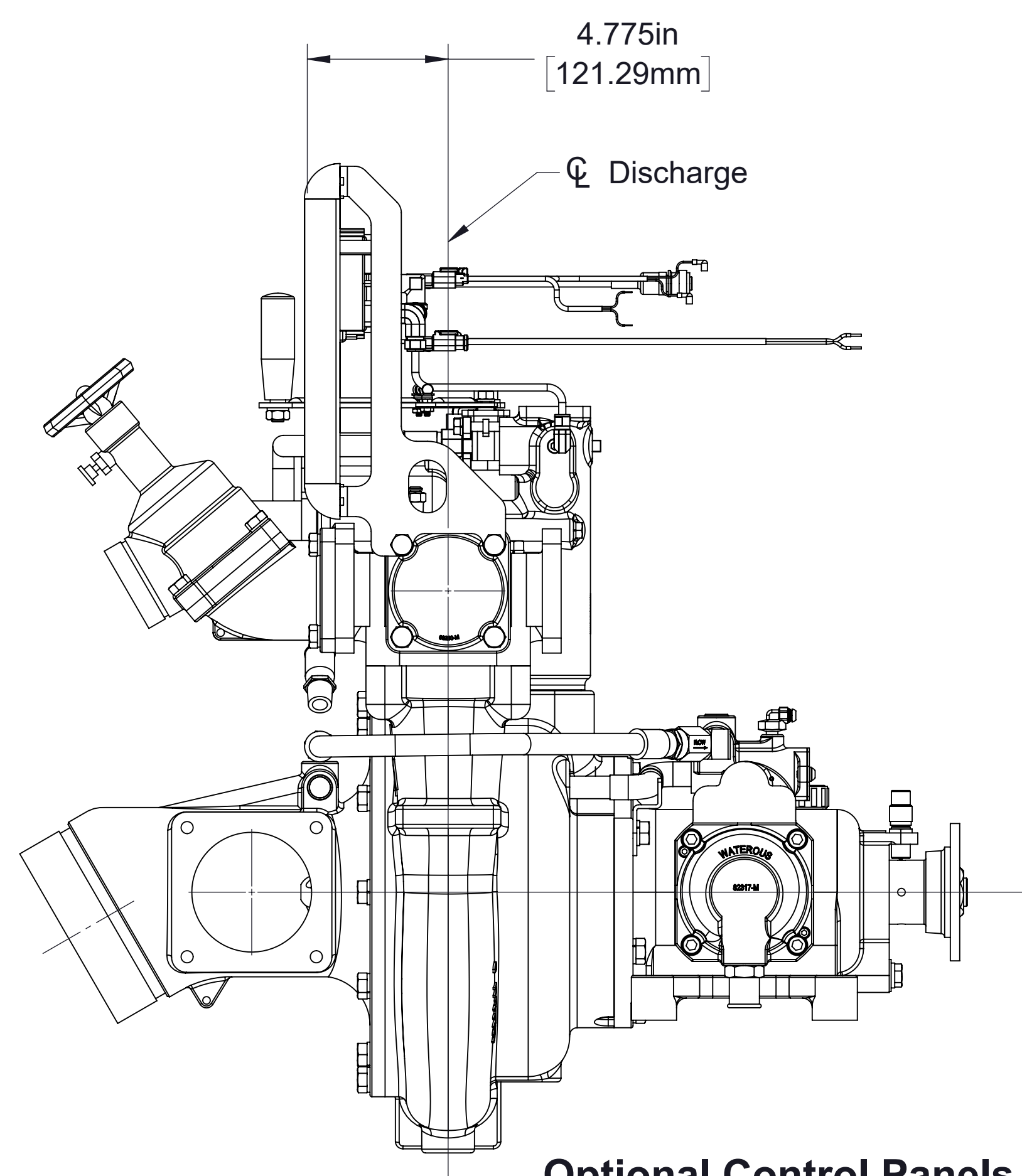
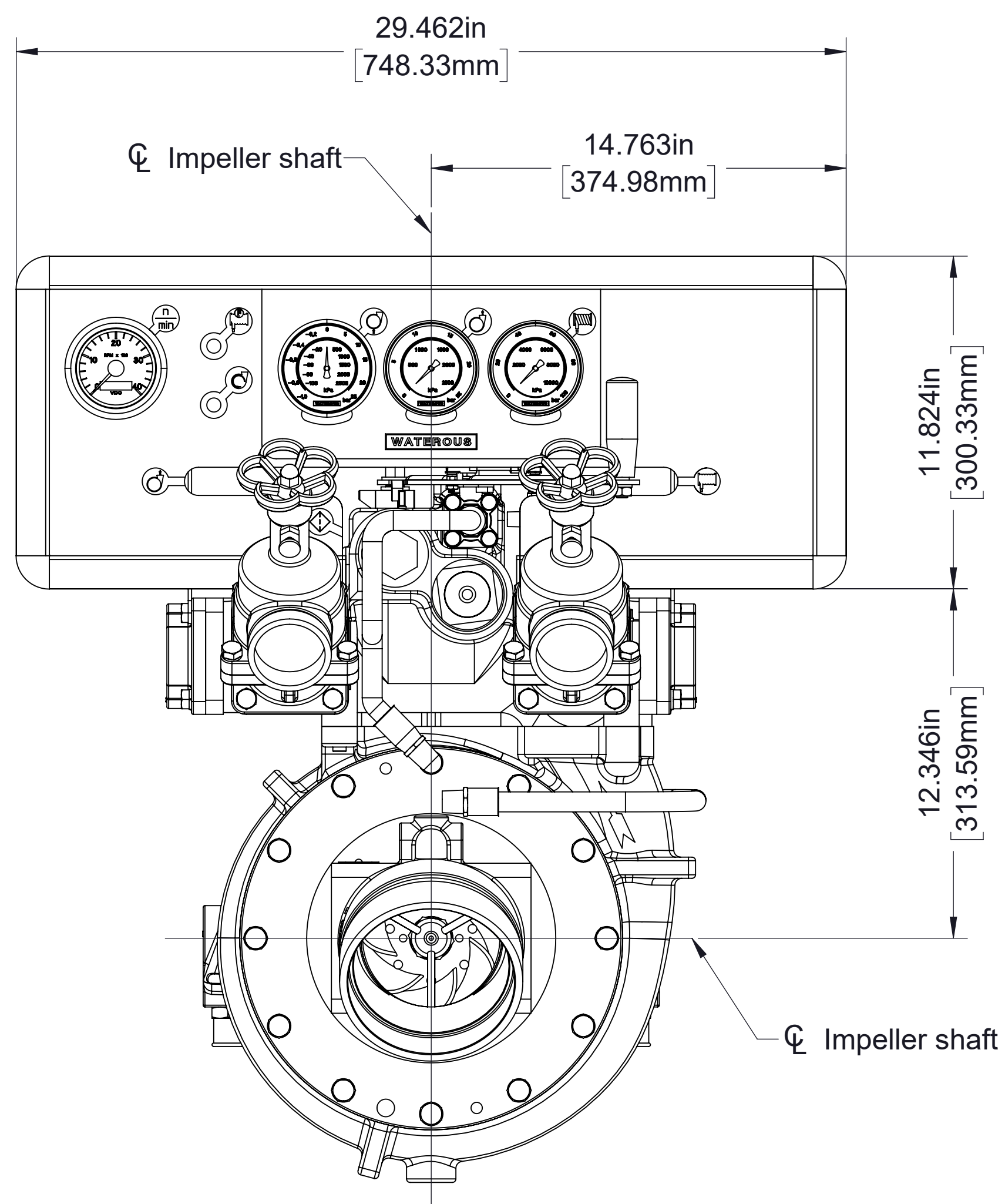

Optional Control Panels

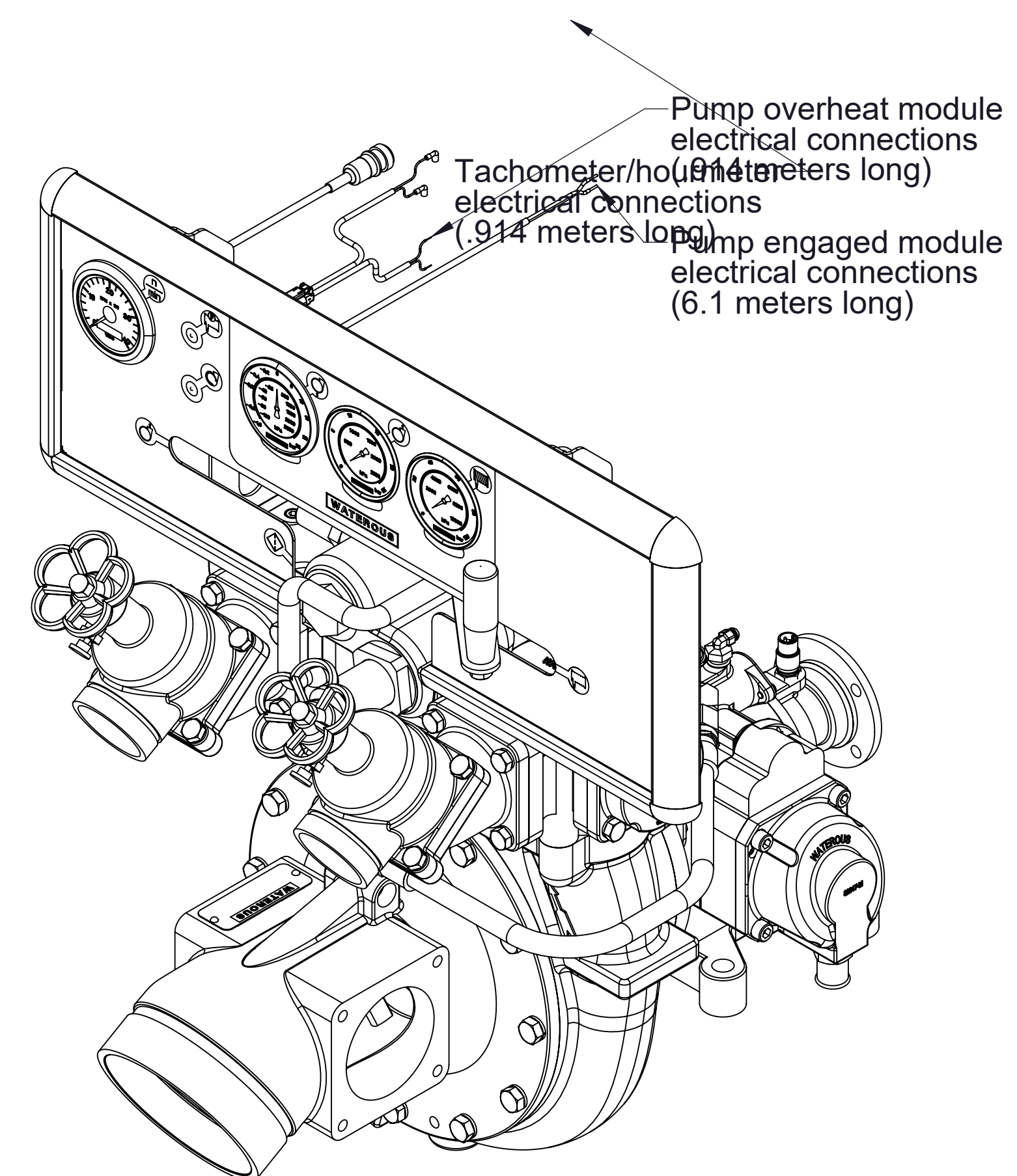

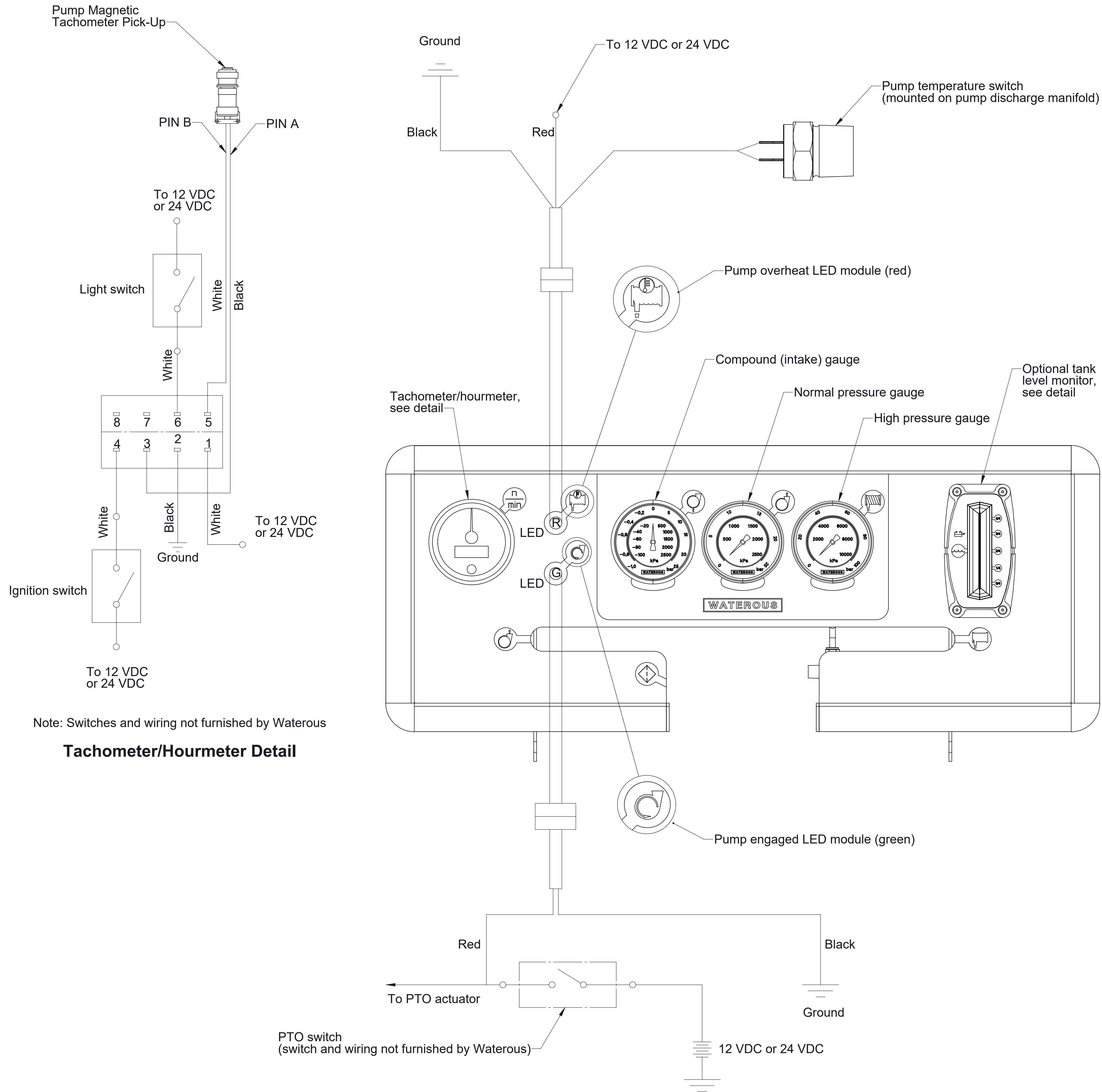

Note: Switches and wiring not furnished by Waterous

Tachometer/Hourmeter Detail

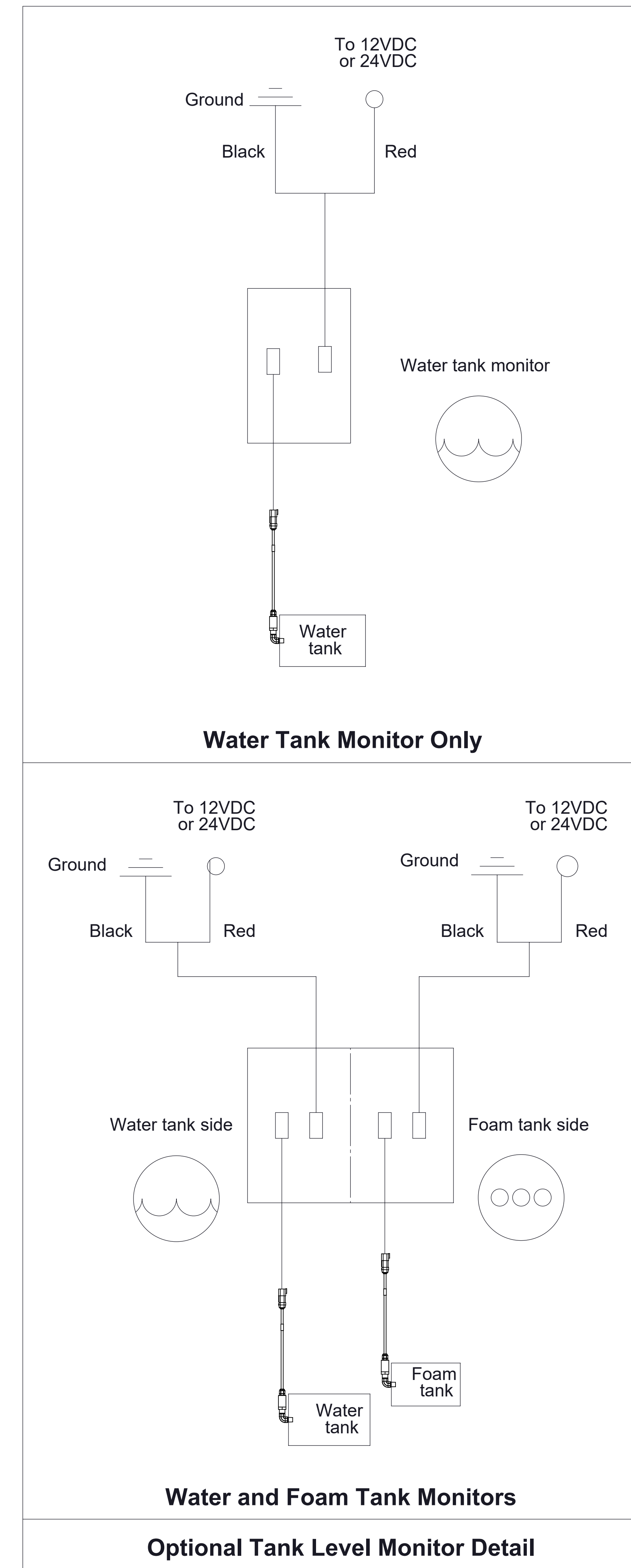
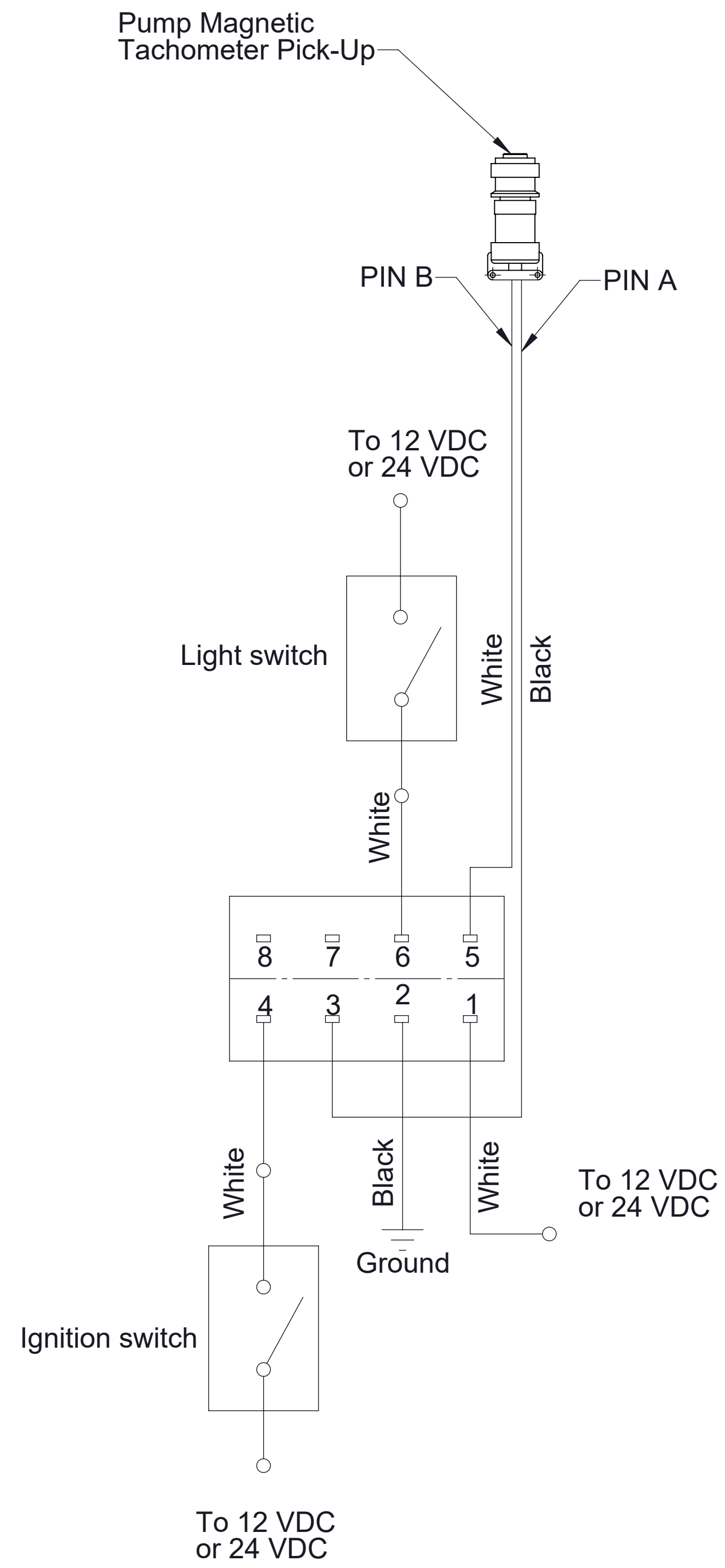

Optional Control Panel Wiring Schematic

Compound Gauge
Panel Cutout
Ø3.19in/81.03mm

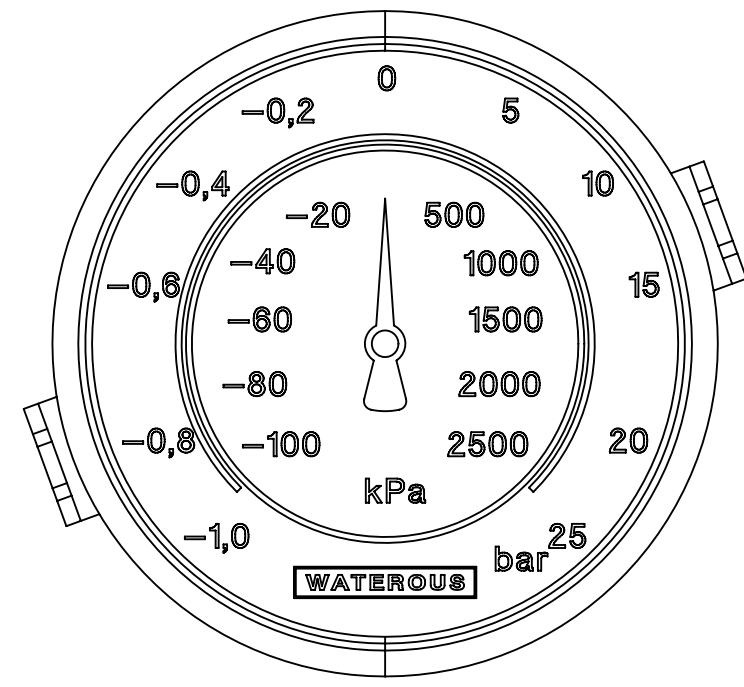

Tachometer/Hourmeter
Panel Cutout
Ø3.375in/85.73mm

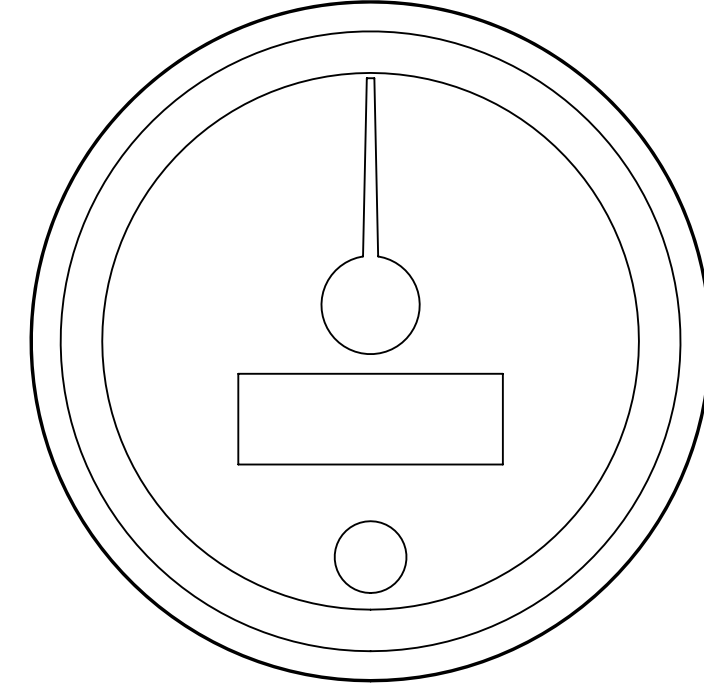

Normal Pressure Gauge
Panel Cutout
Ø3.19in/81.03mm

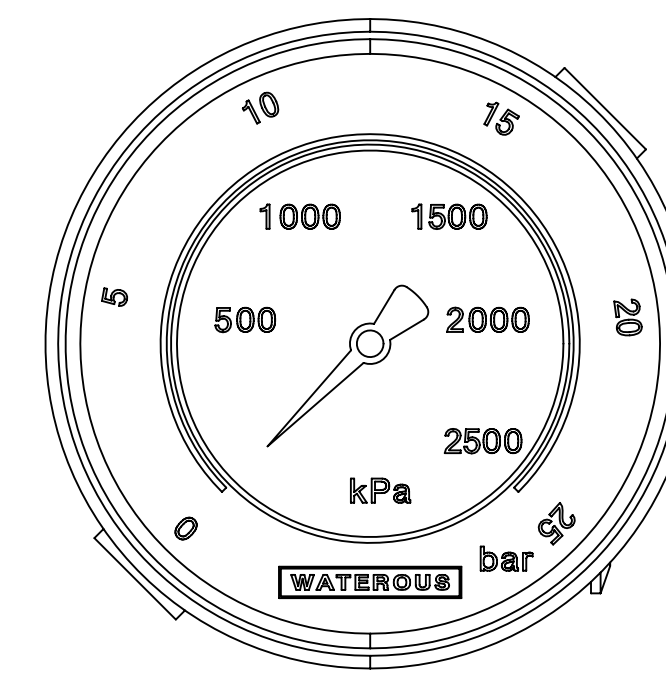

High Pressure Gauge
Panel Cutout
Ø3.19in/81.03mm

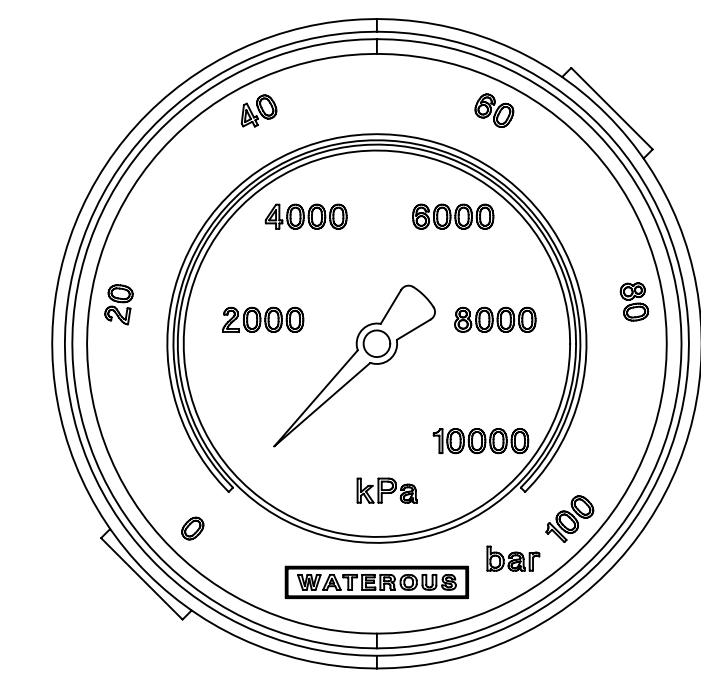

Pump Panel Instrument Package

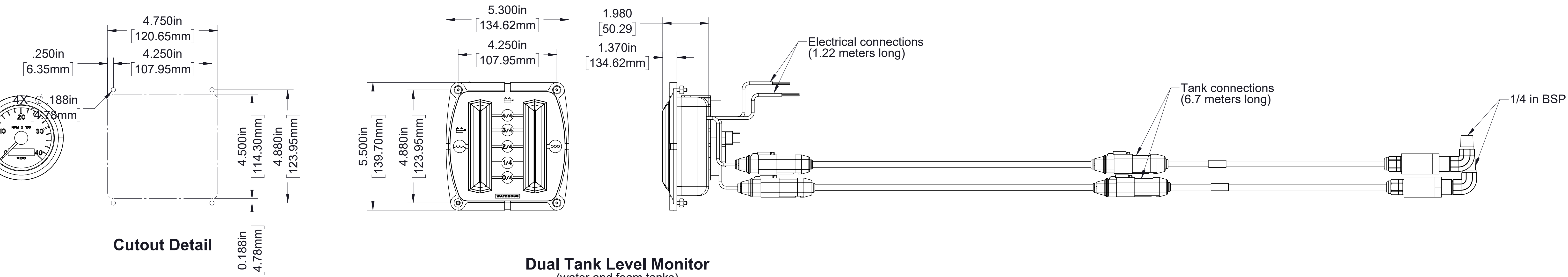

Cutout Detail

Dual Tank Level Monitor
(water and foam tanks)

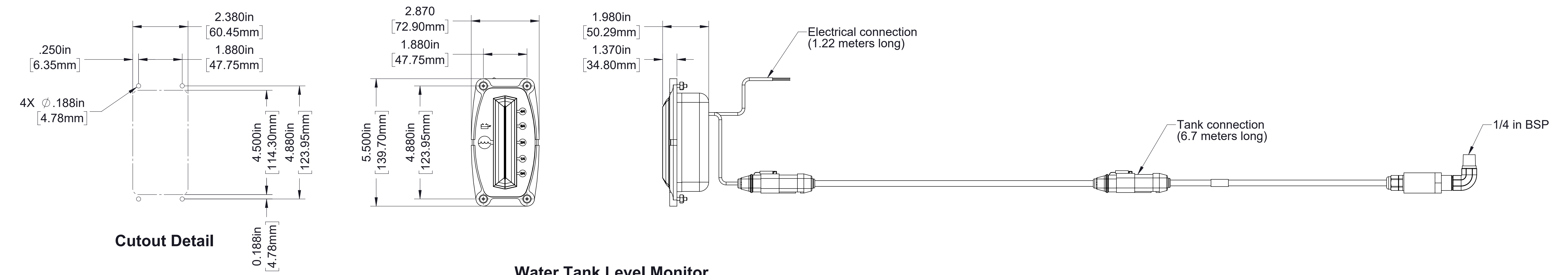

Cutout Detail

Water Tank Level Monitor

Optional Gauges and Monitors