

Dimensional Drawings for Waterous E500 Series Motor Pump

Pump and Engine

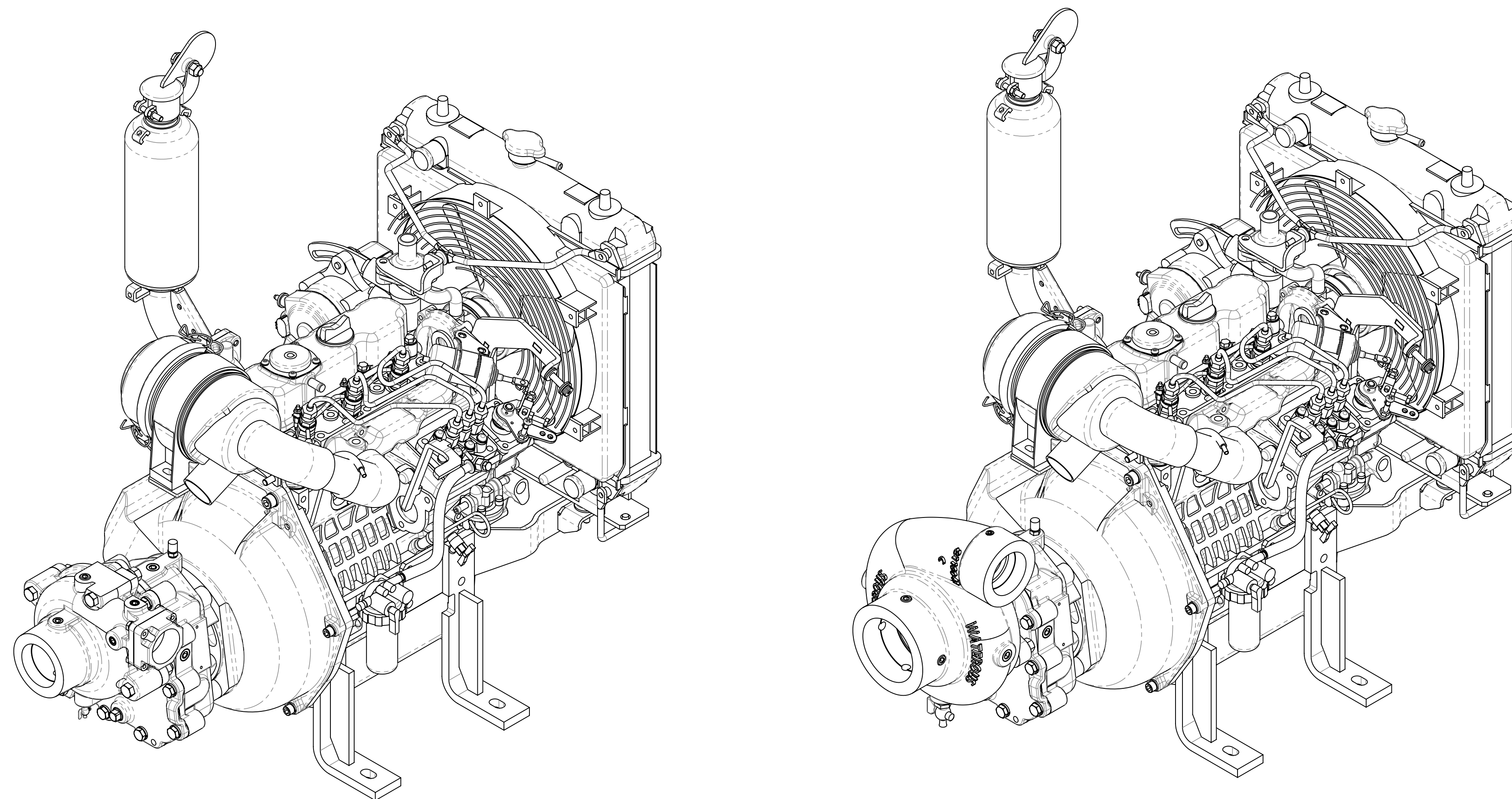

Model E501-C

Model E511-C

Optional Instrument Panel

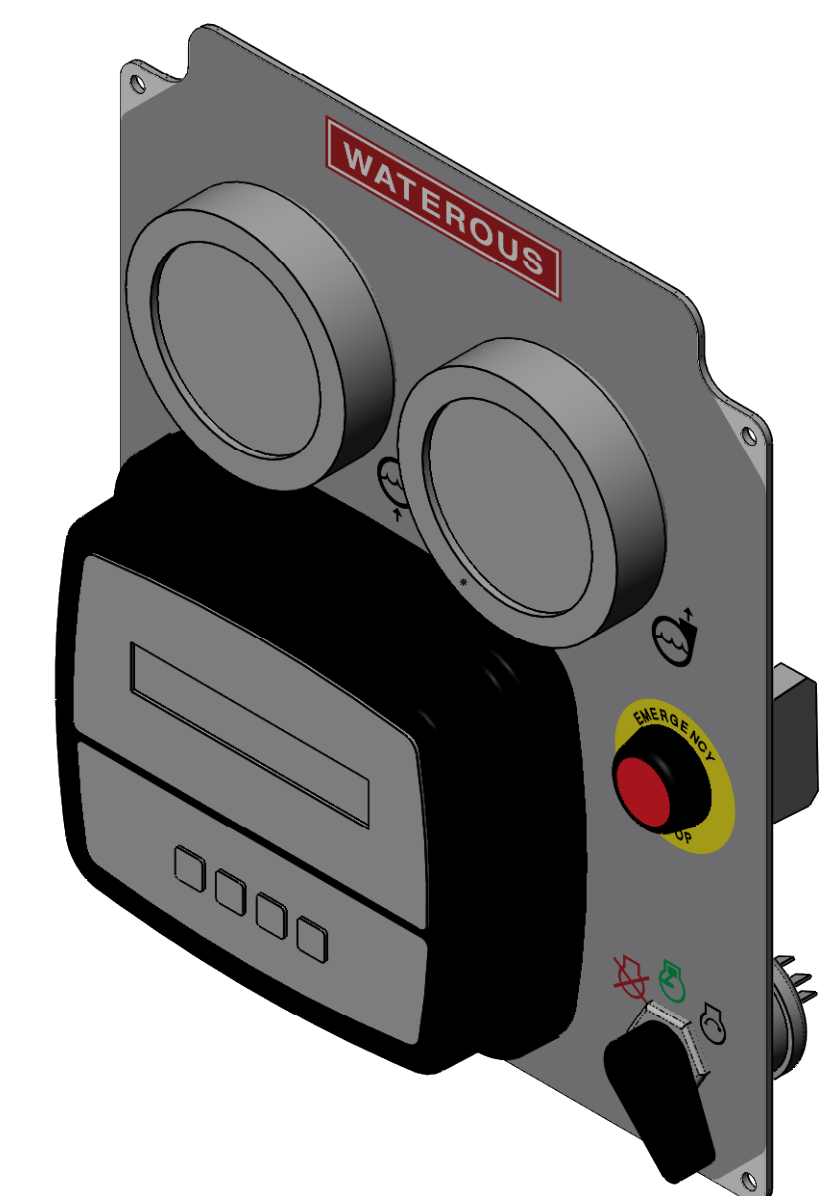
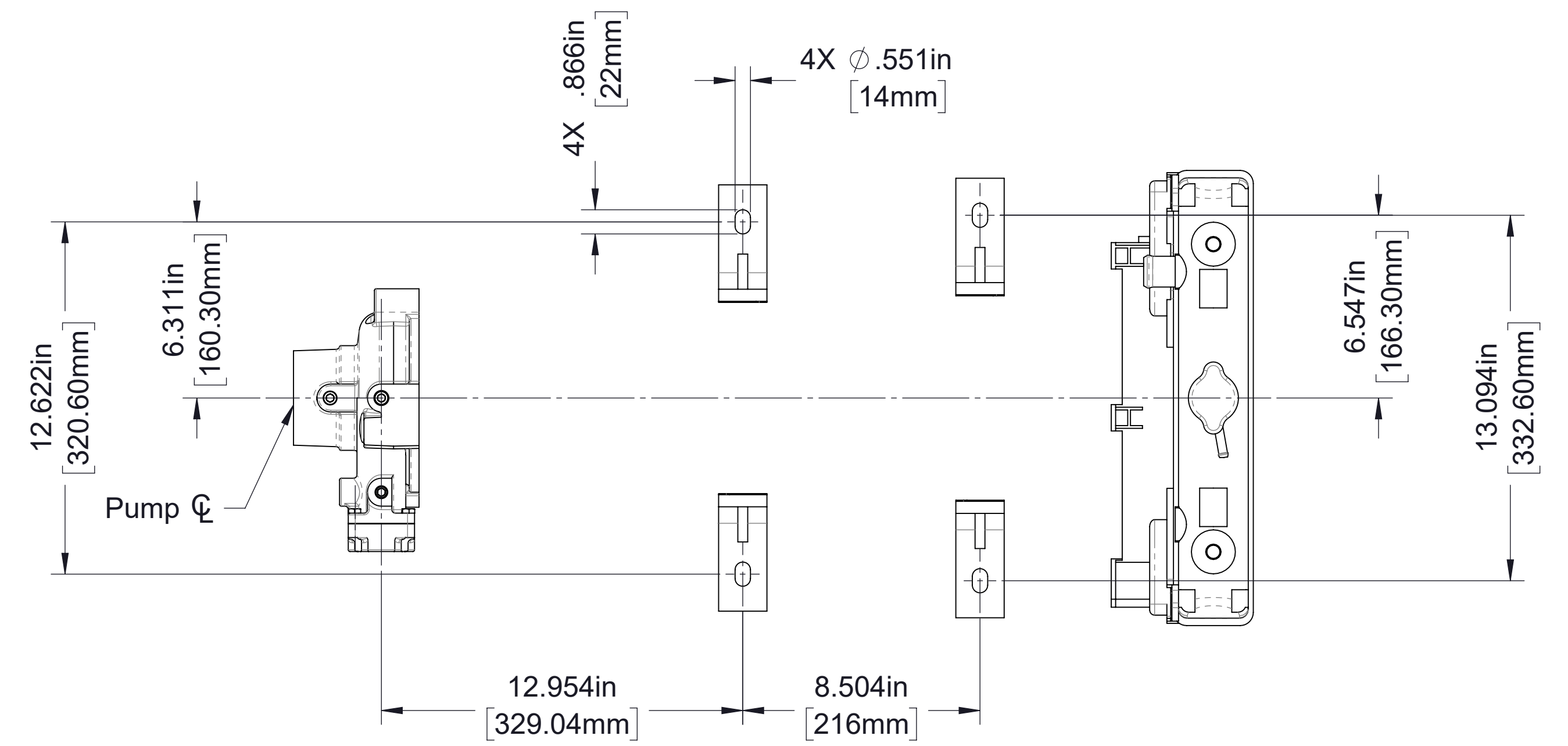
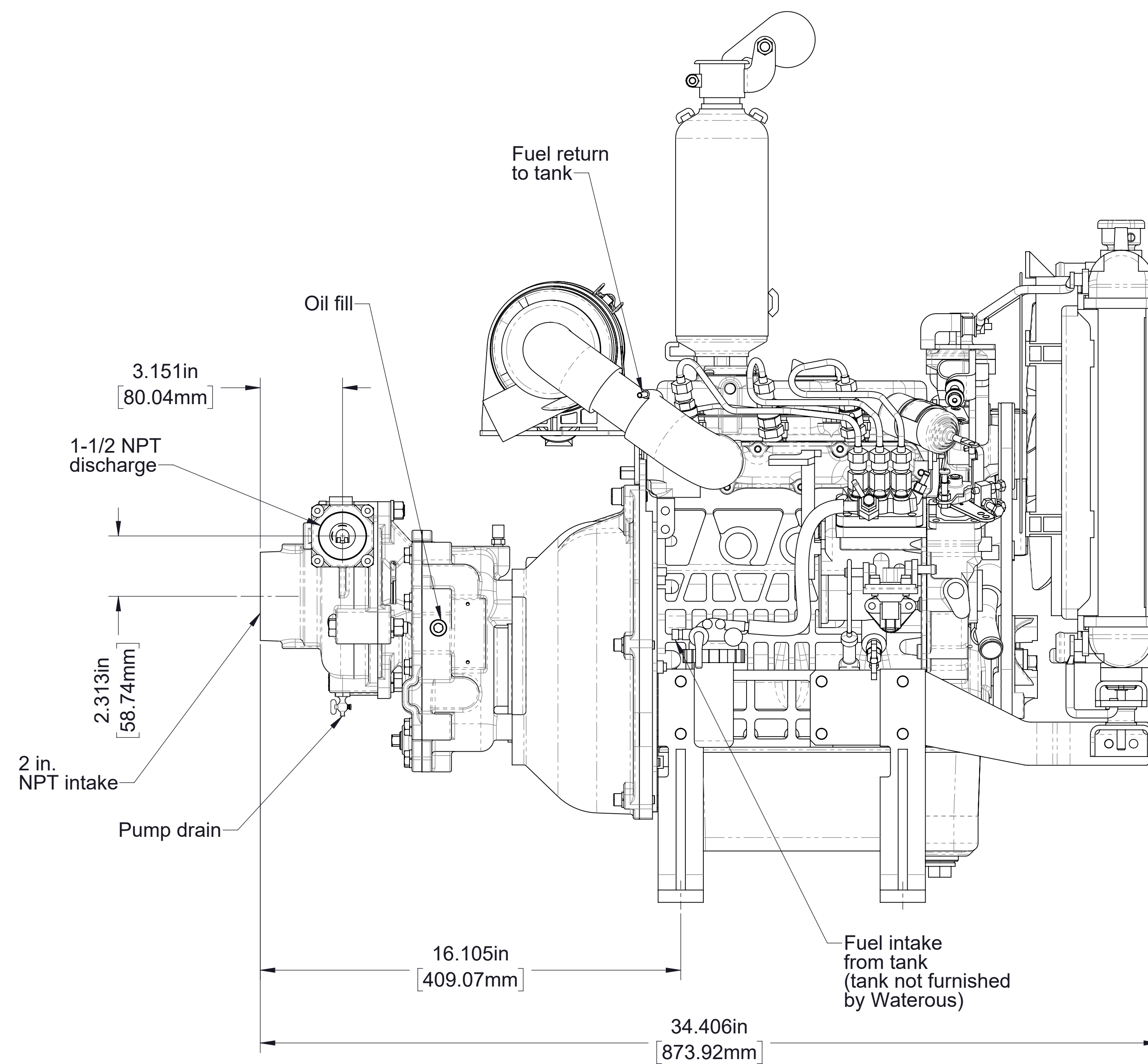
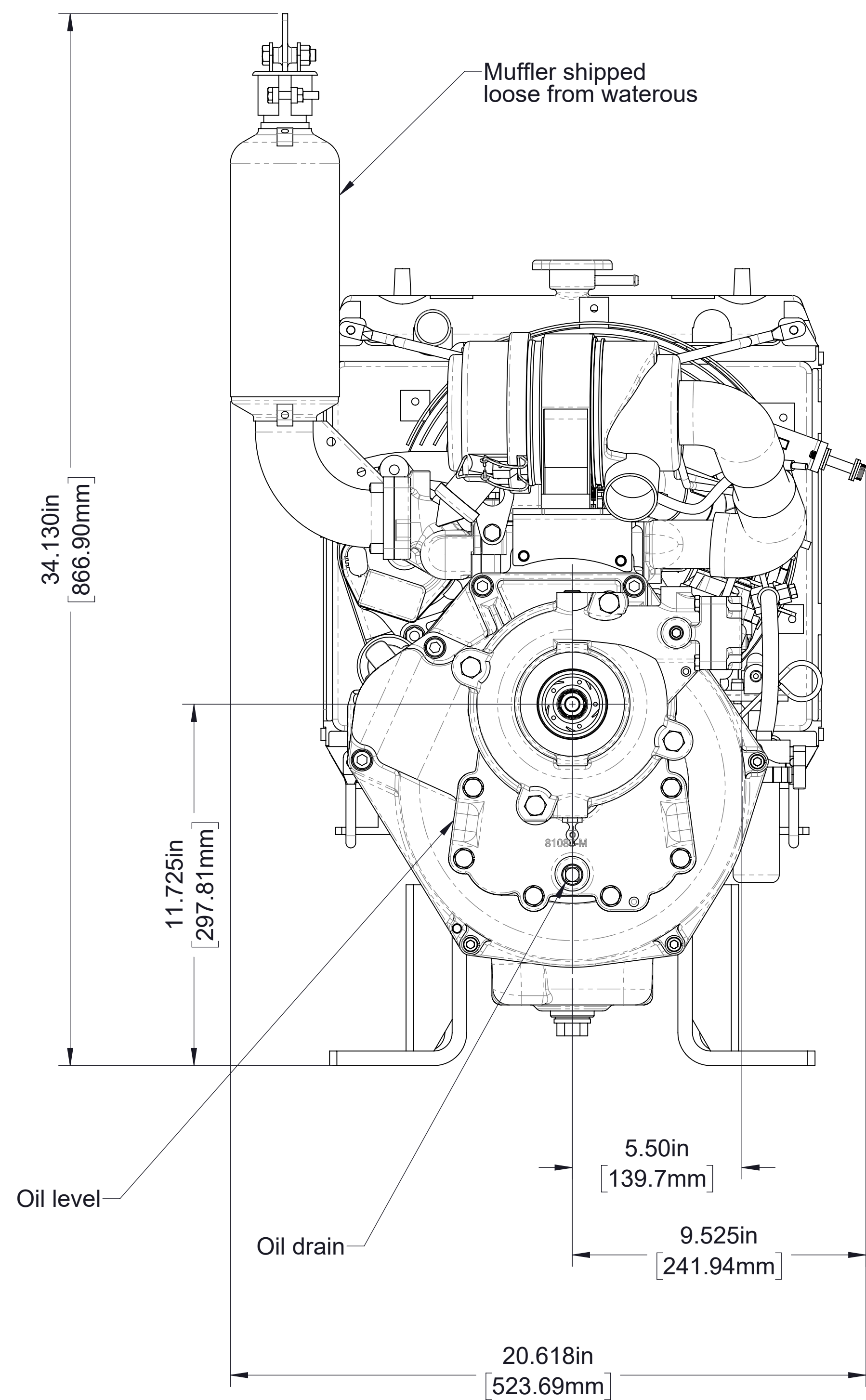

Table of Contents

Pumps:
Model E501-C Diesel Engine (2 in. NPT Intake 1-1/2 in. NPT Discharge).....3
Model E511-C Diesel Engine (3 in. NPT or Victaulic intake, 2 in. NPT or Victaulic Discharge)4
Available Discharge Positions5

Optional Instrument Panel:
Models E501-C, E511-C
Single and Dual Panel6

Optional Priming System:
Primers, Valves and Lubricant Tank7



Mounting Pad Details

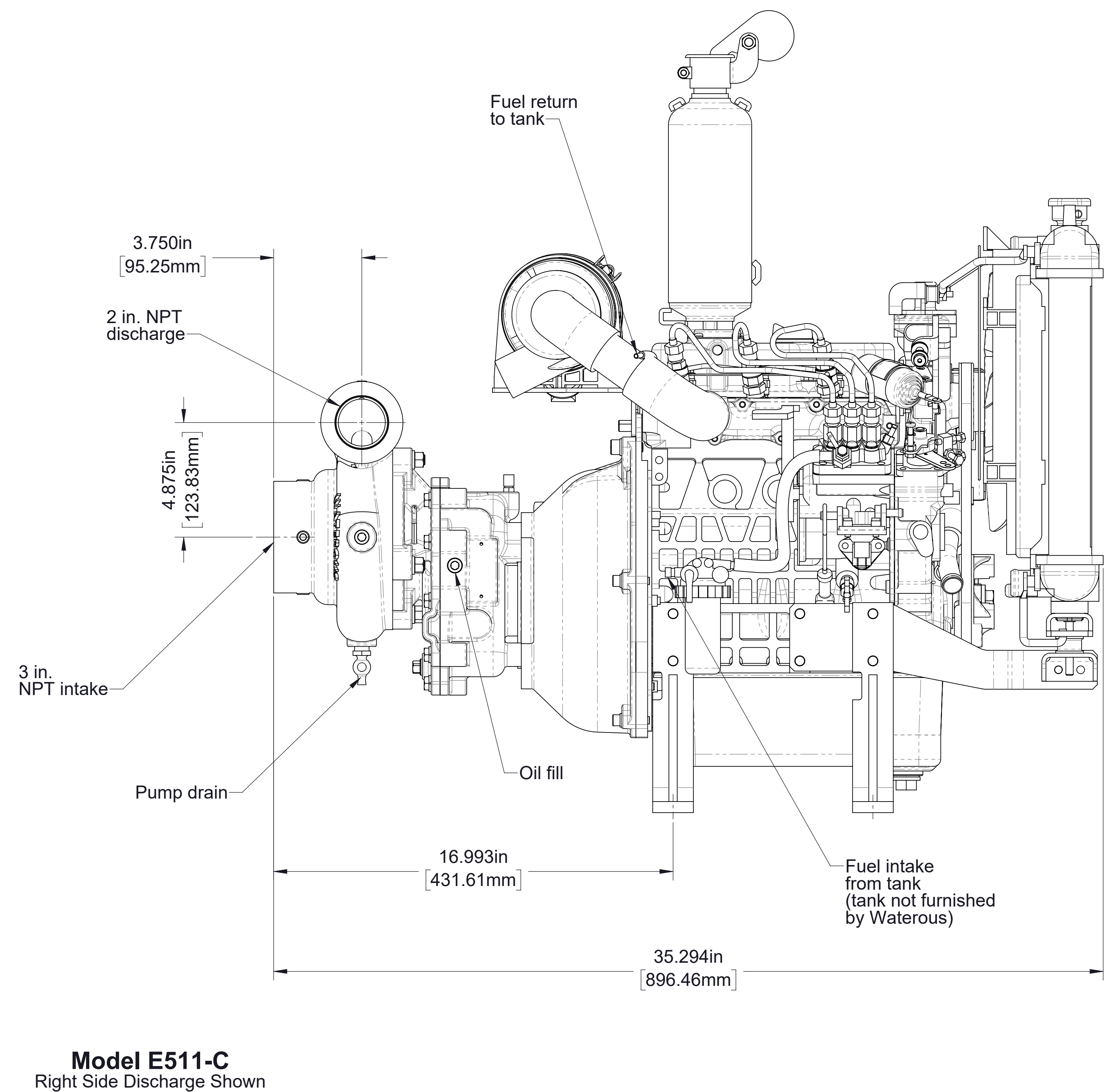
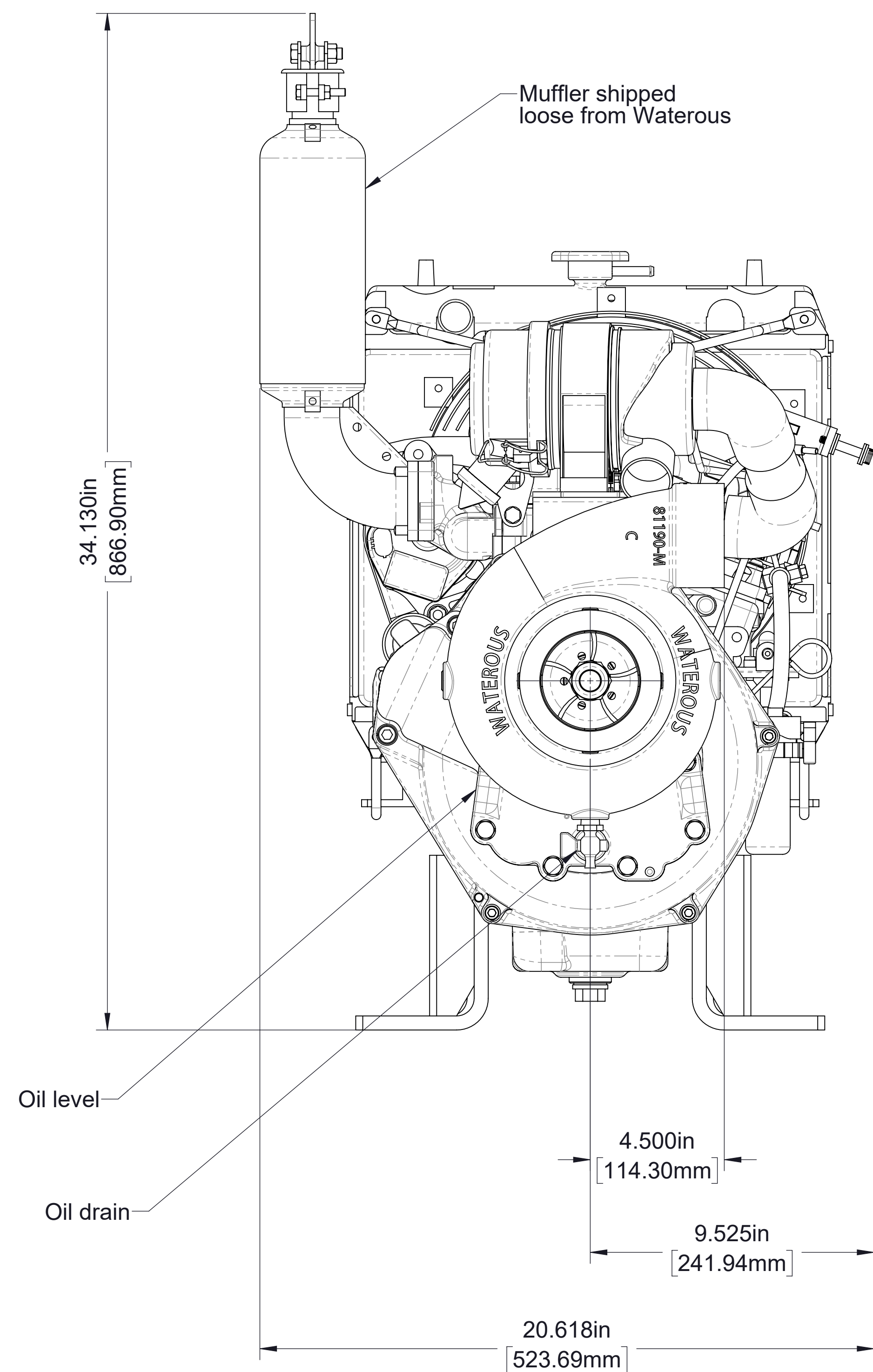
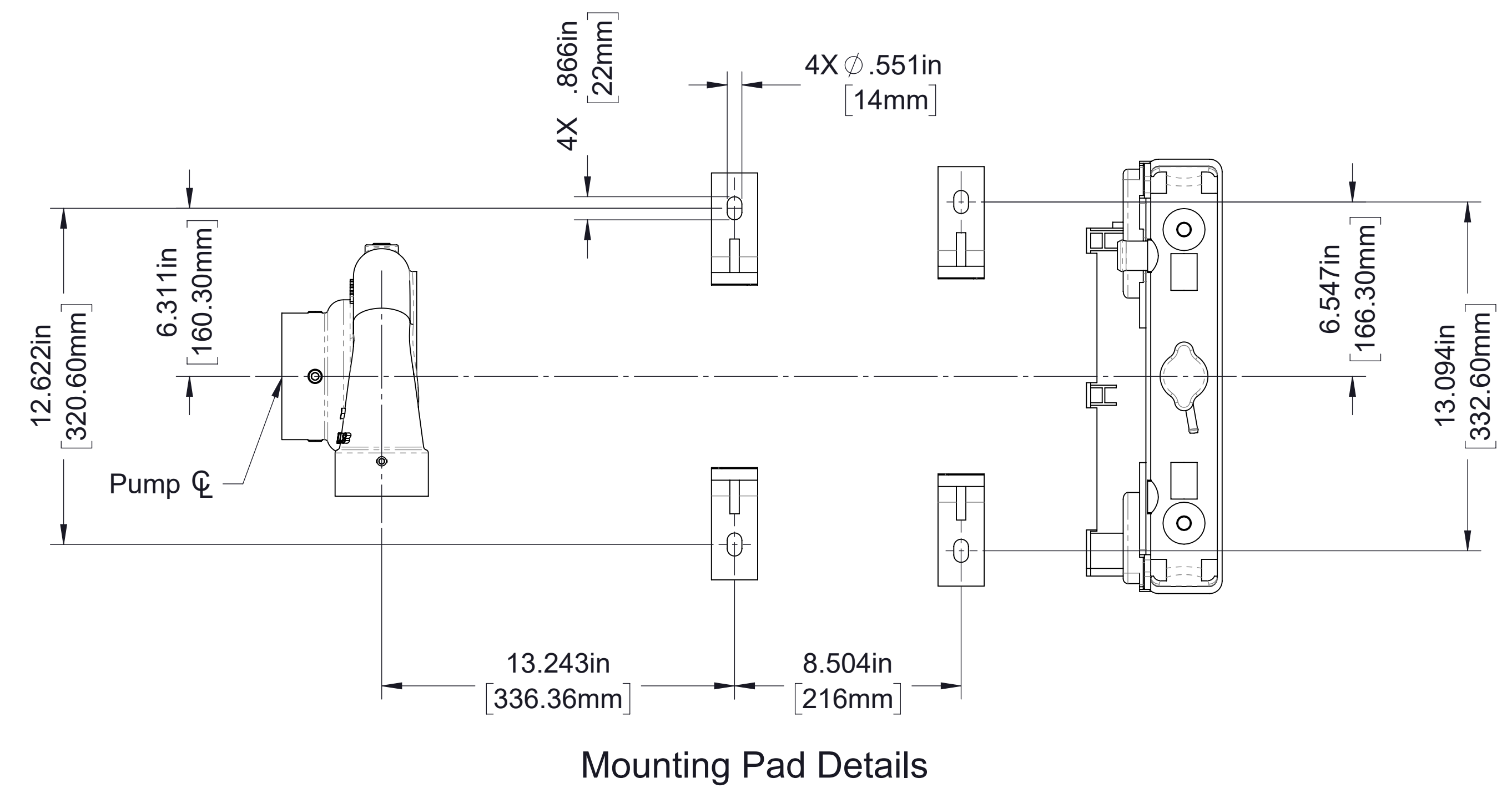
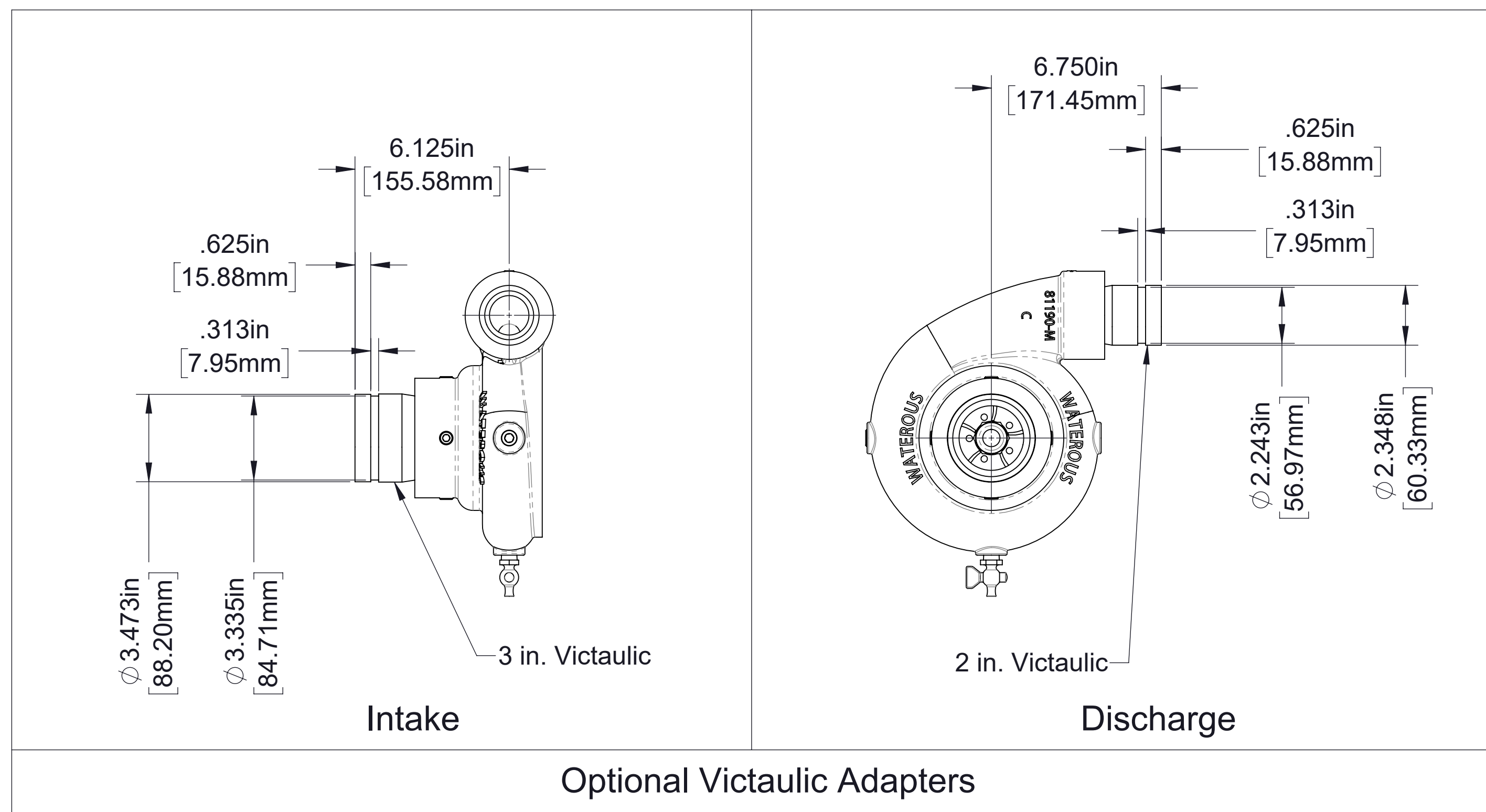

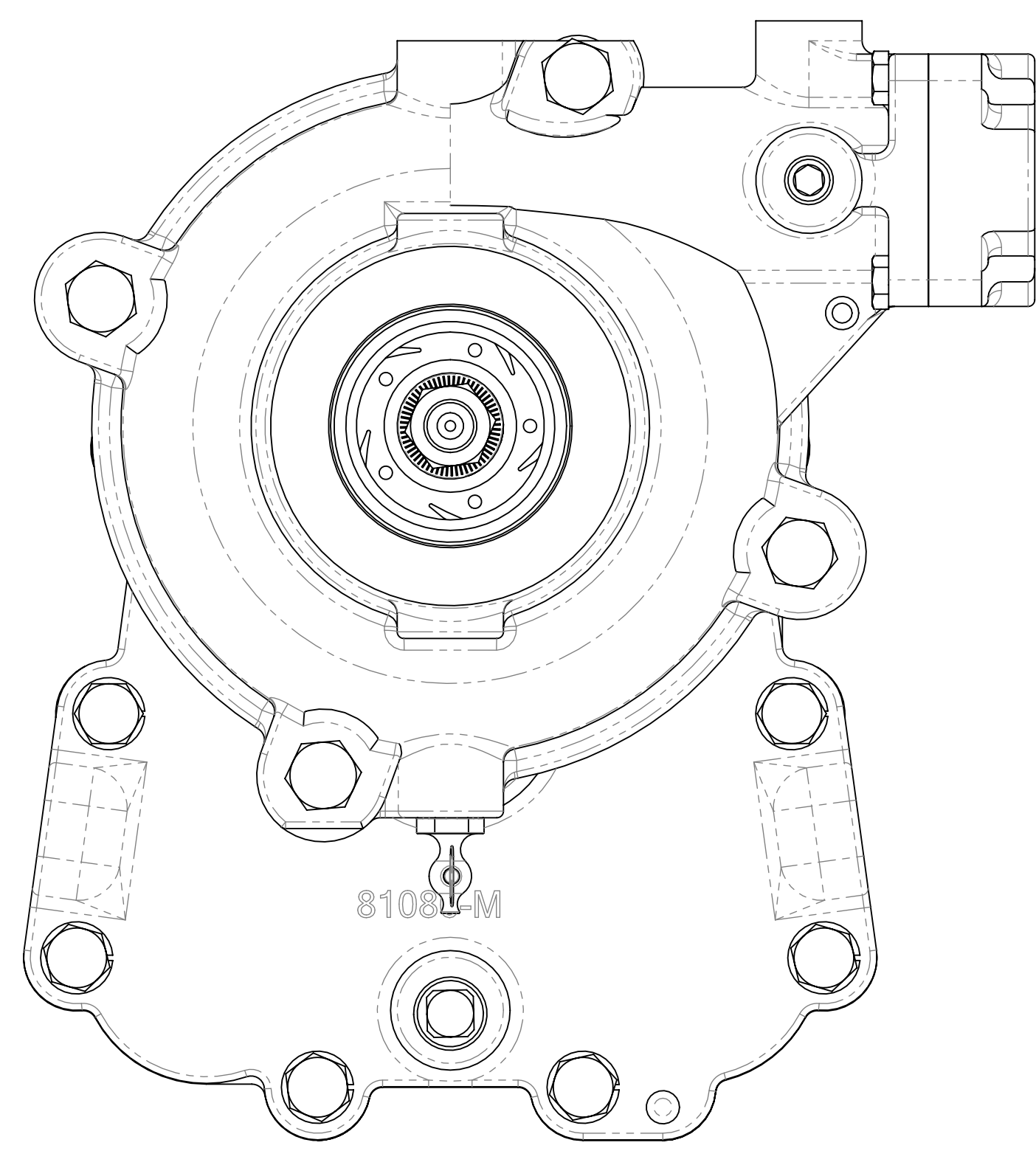

Right (Standard)

Models: E501-C, E501

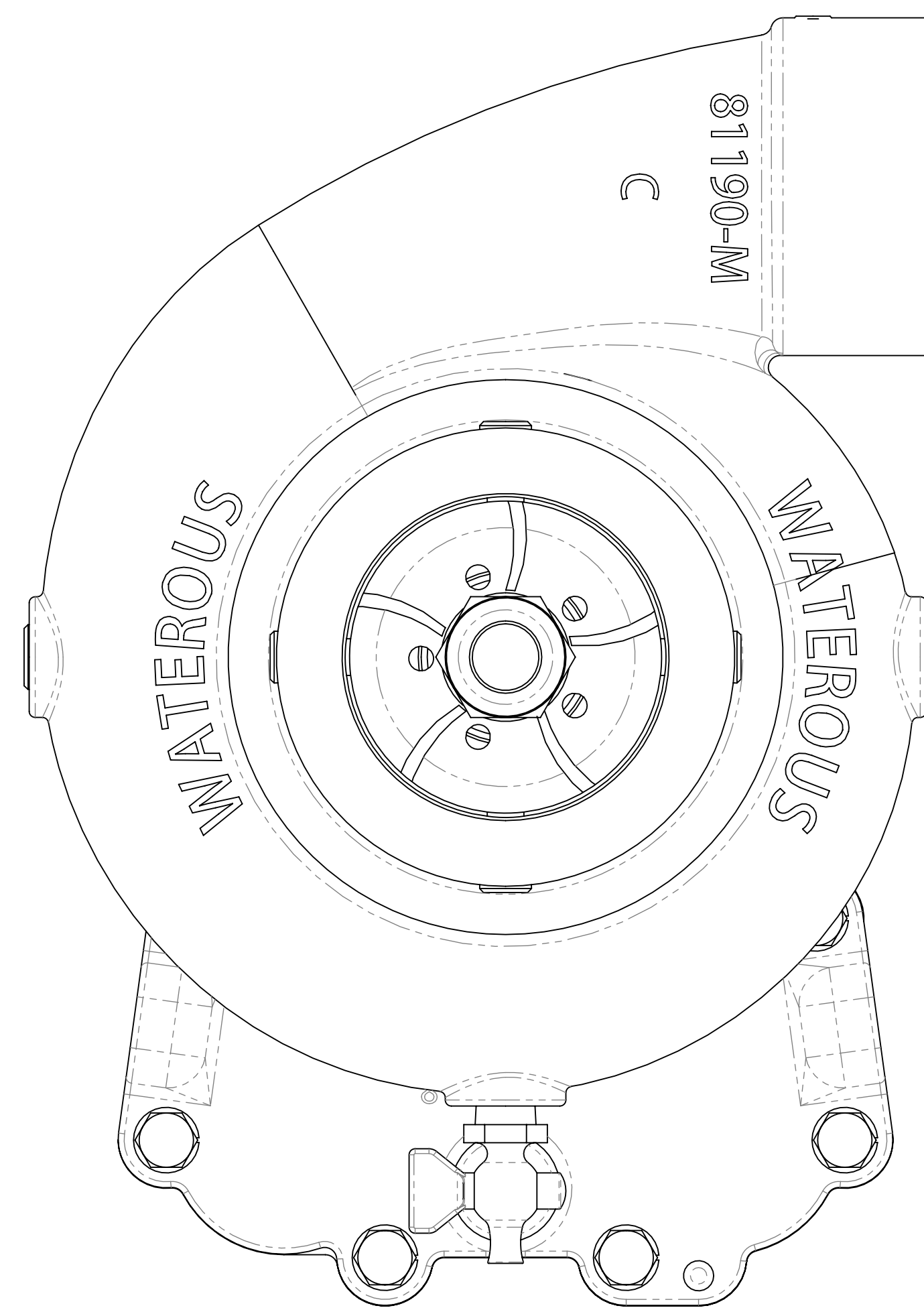

Right (Standard)

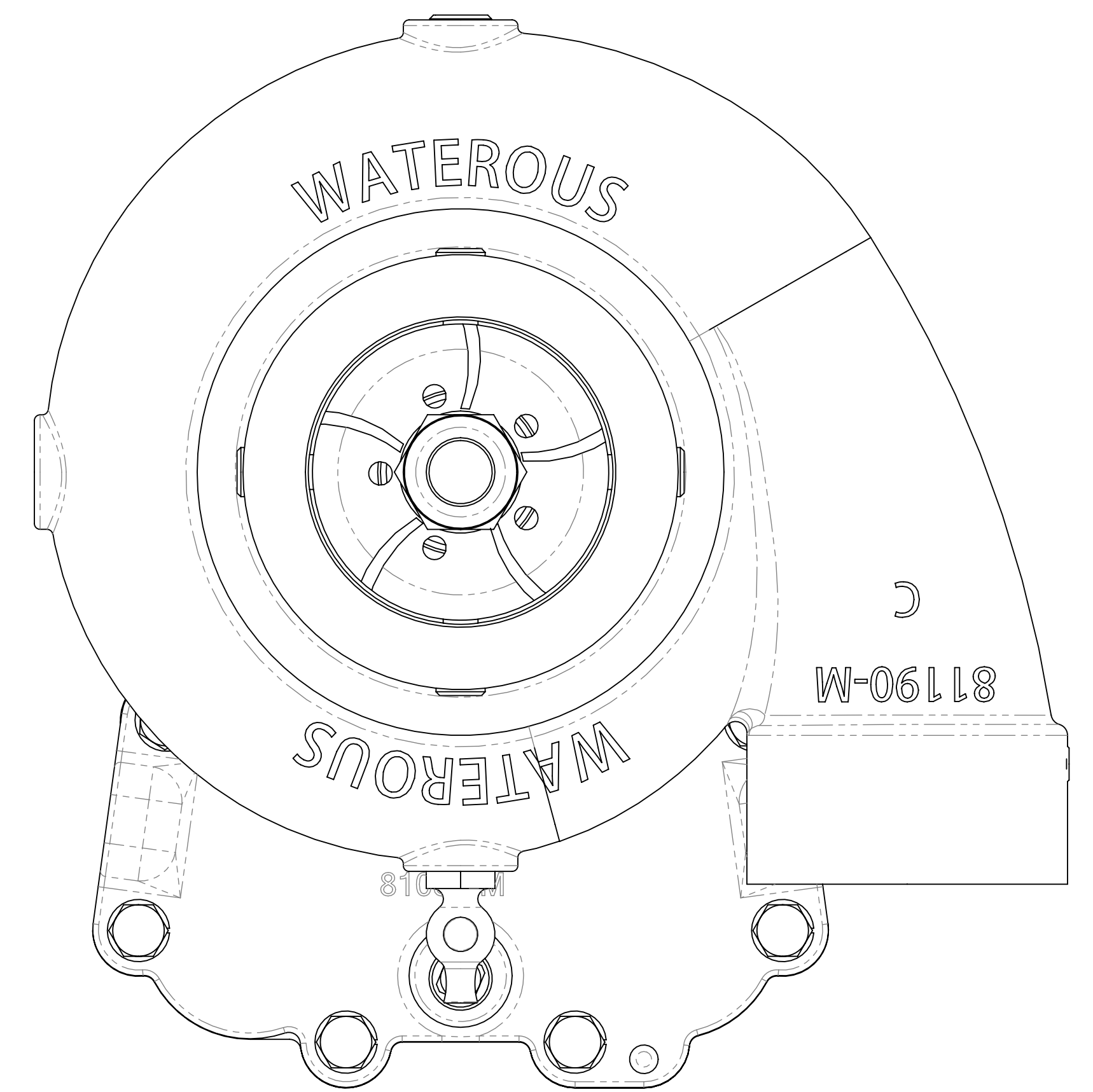

Down

Models: E511-C, E511

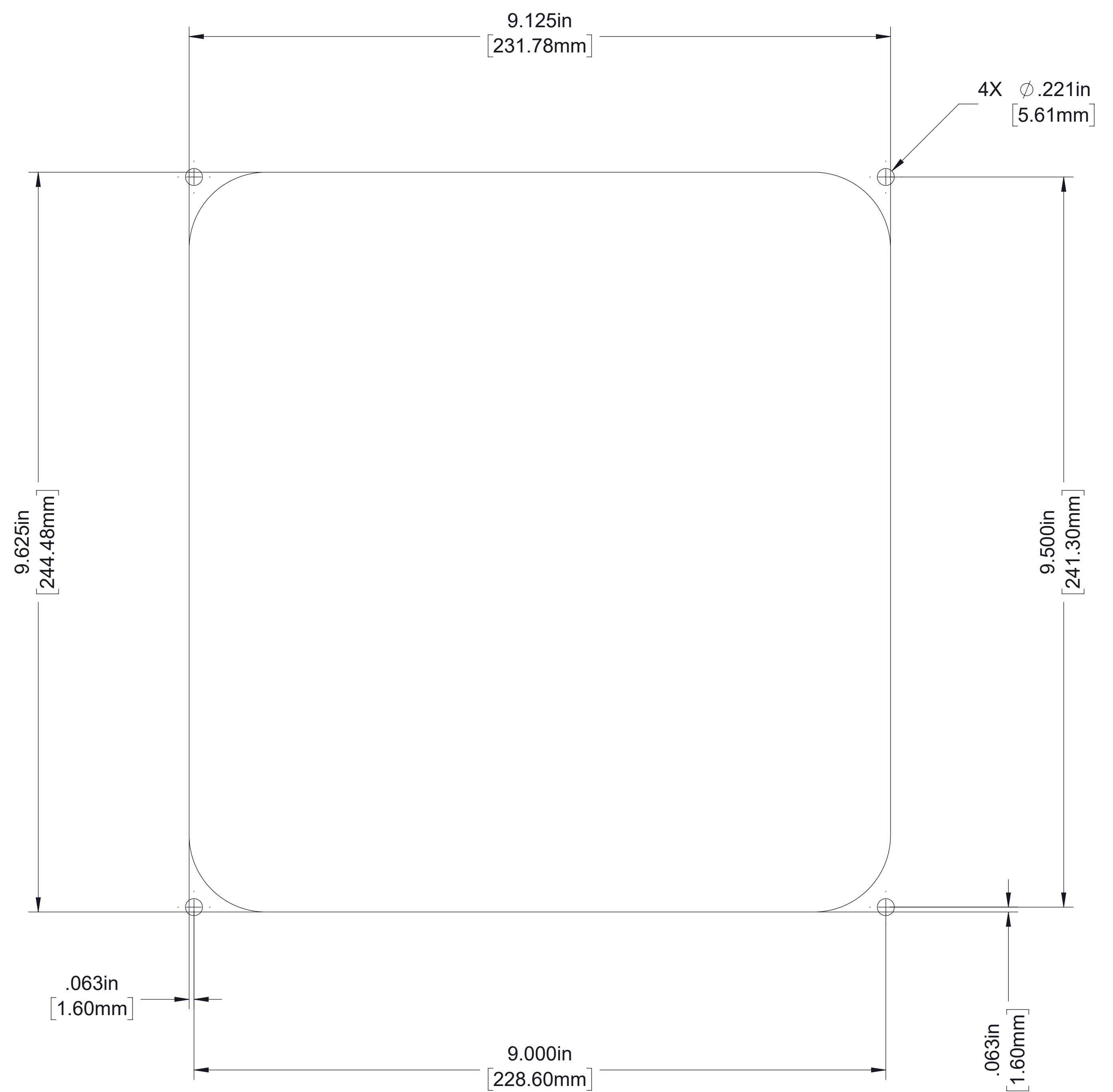
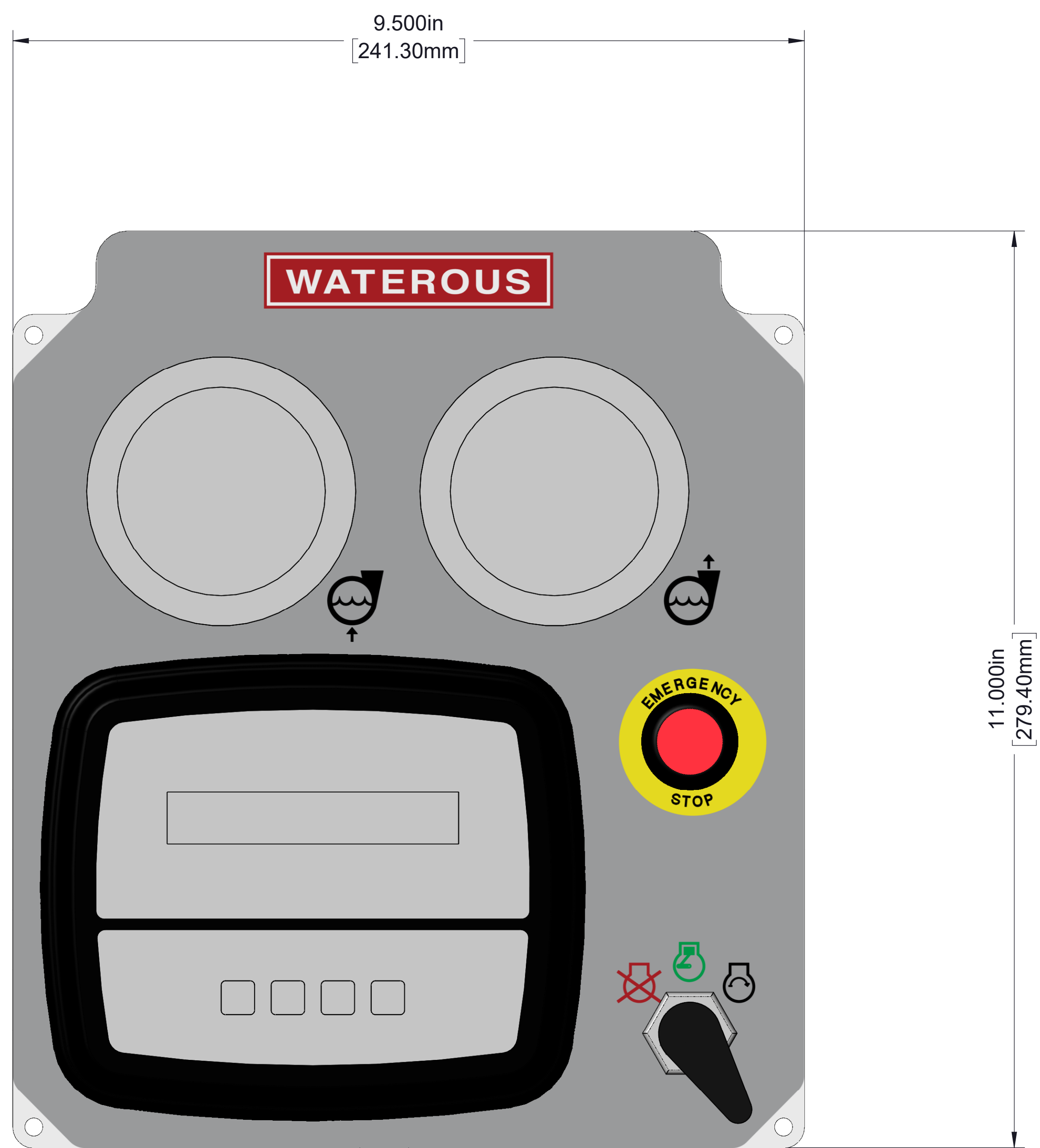

Cut-Out for Panel

Optional Panel

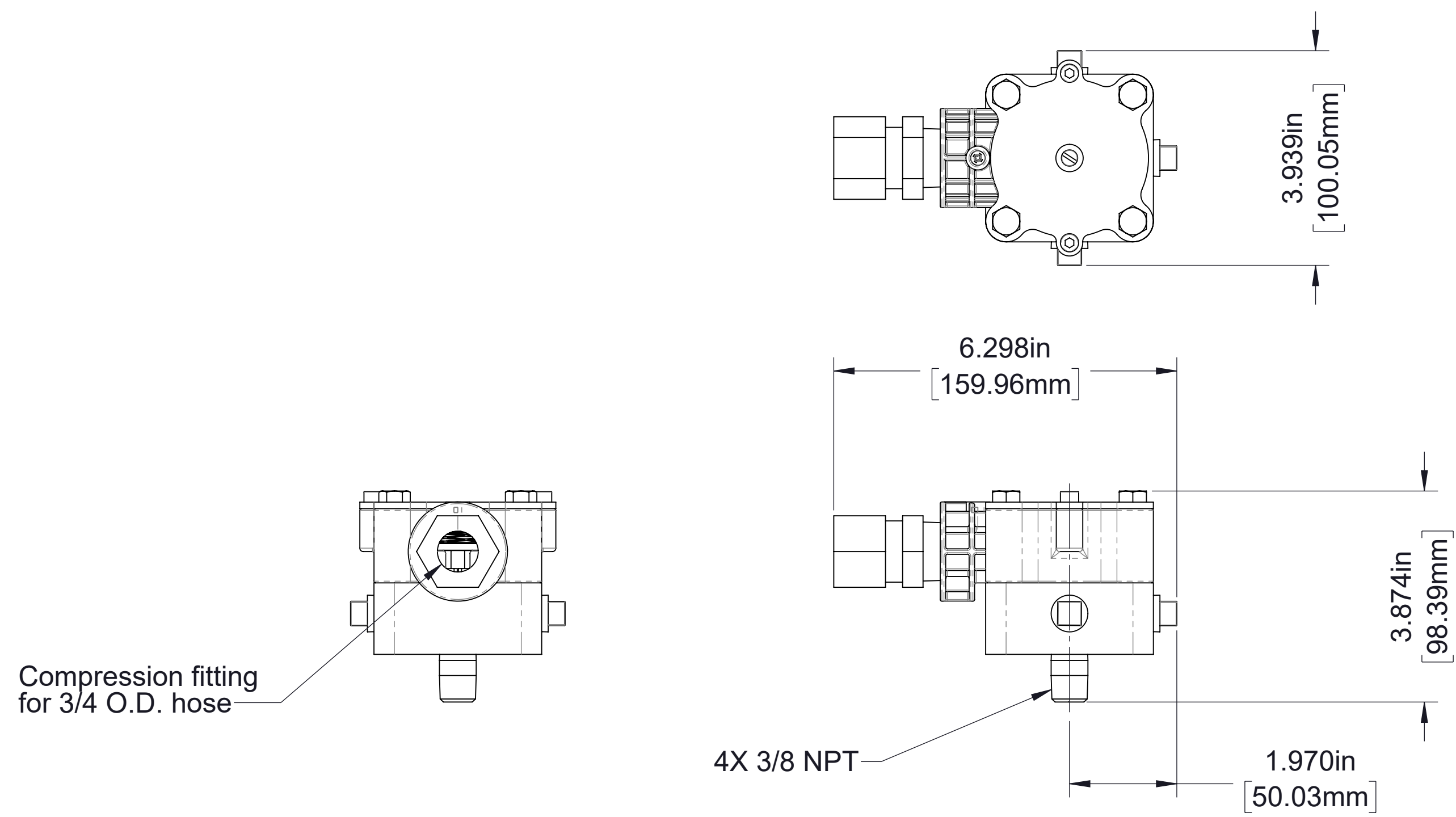

Vap Priming Valve

Notes:

1. Vap priming valve must be mounted in a level position with bronze adapter facing down to prevent water from getting trapped in the valve.
2. Priming hose must be 3/4 O.D. LLDPE (linear low-density polyethylene) and shielded from any surface which may wear on the hose.

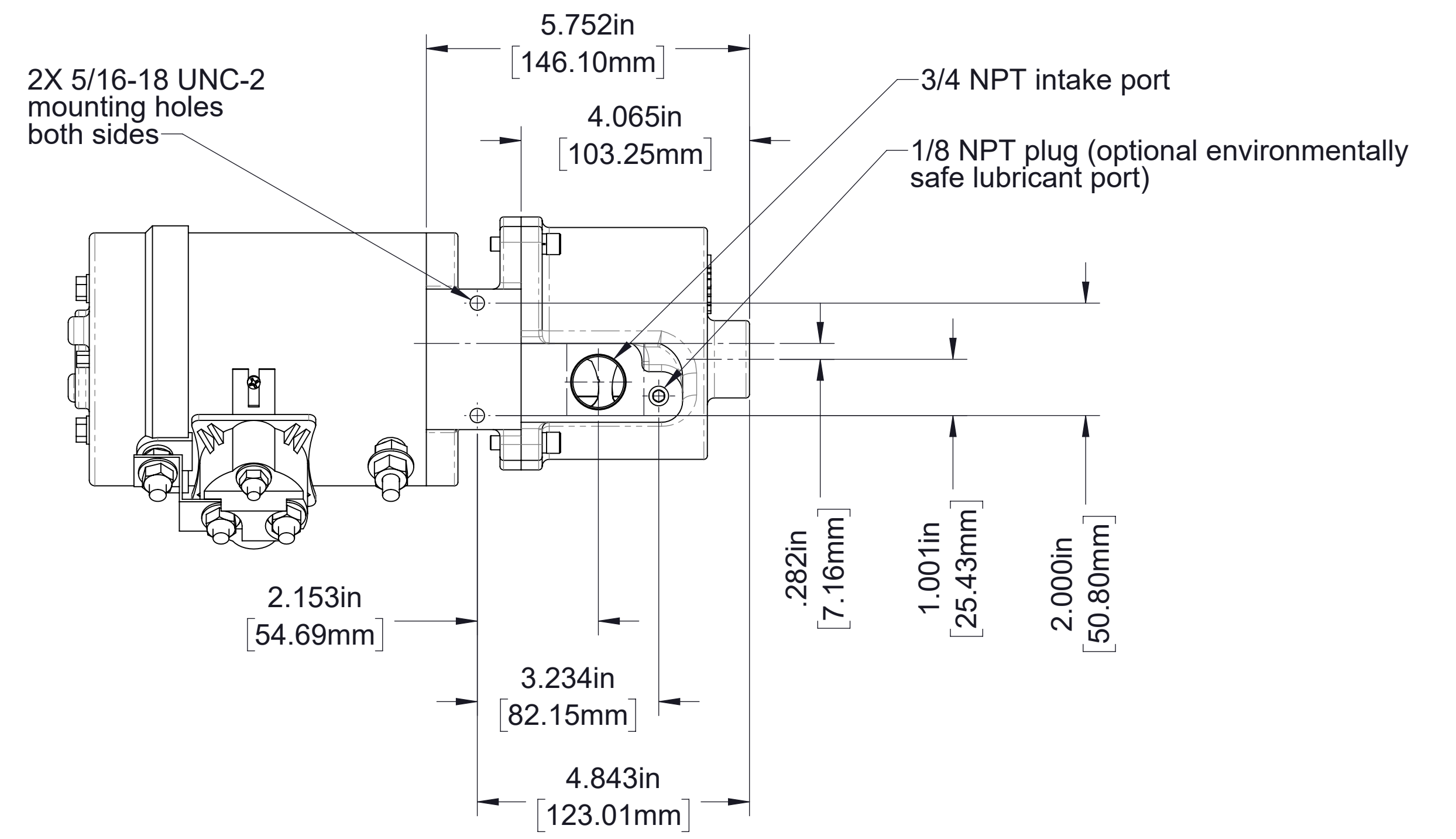

Model VP0S, Rotary Vane, Priming Pump

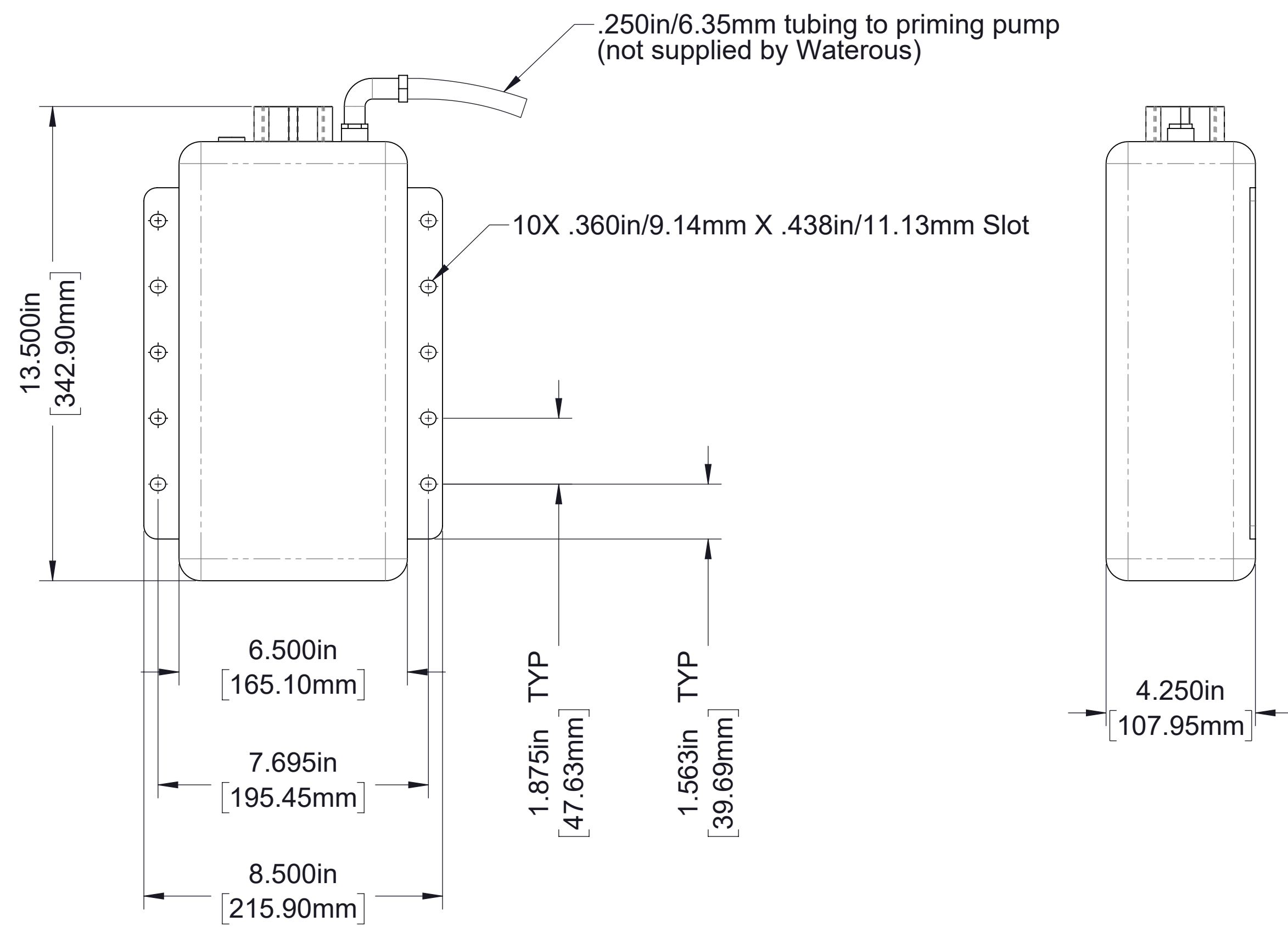

Priming Lubricant Tank
(Capacity 5 quarts/4.73 liters)

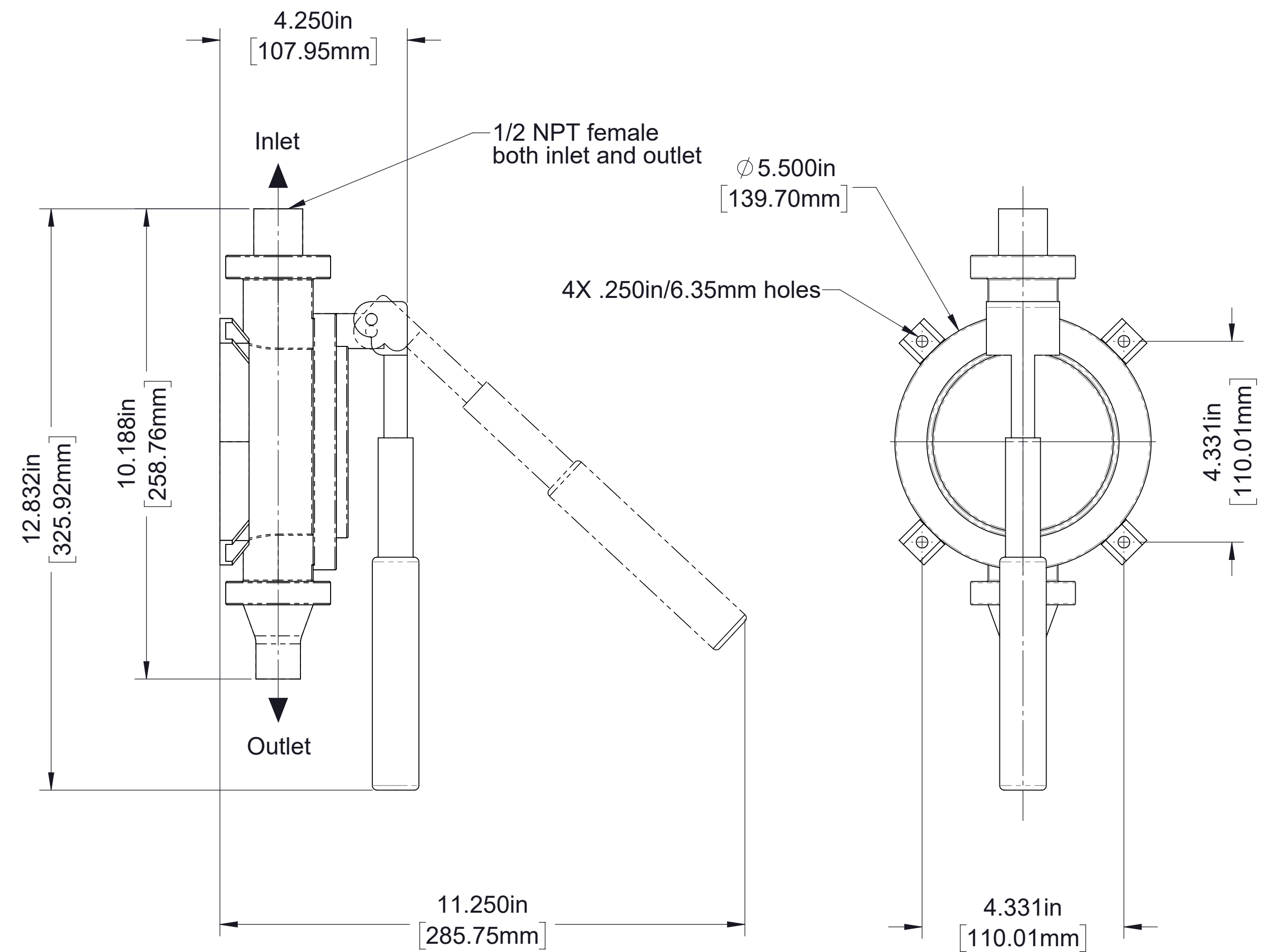

Manual Hand Primer