

CAFS Air Discharge Check Valve Kit Dimensional Drawing

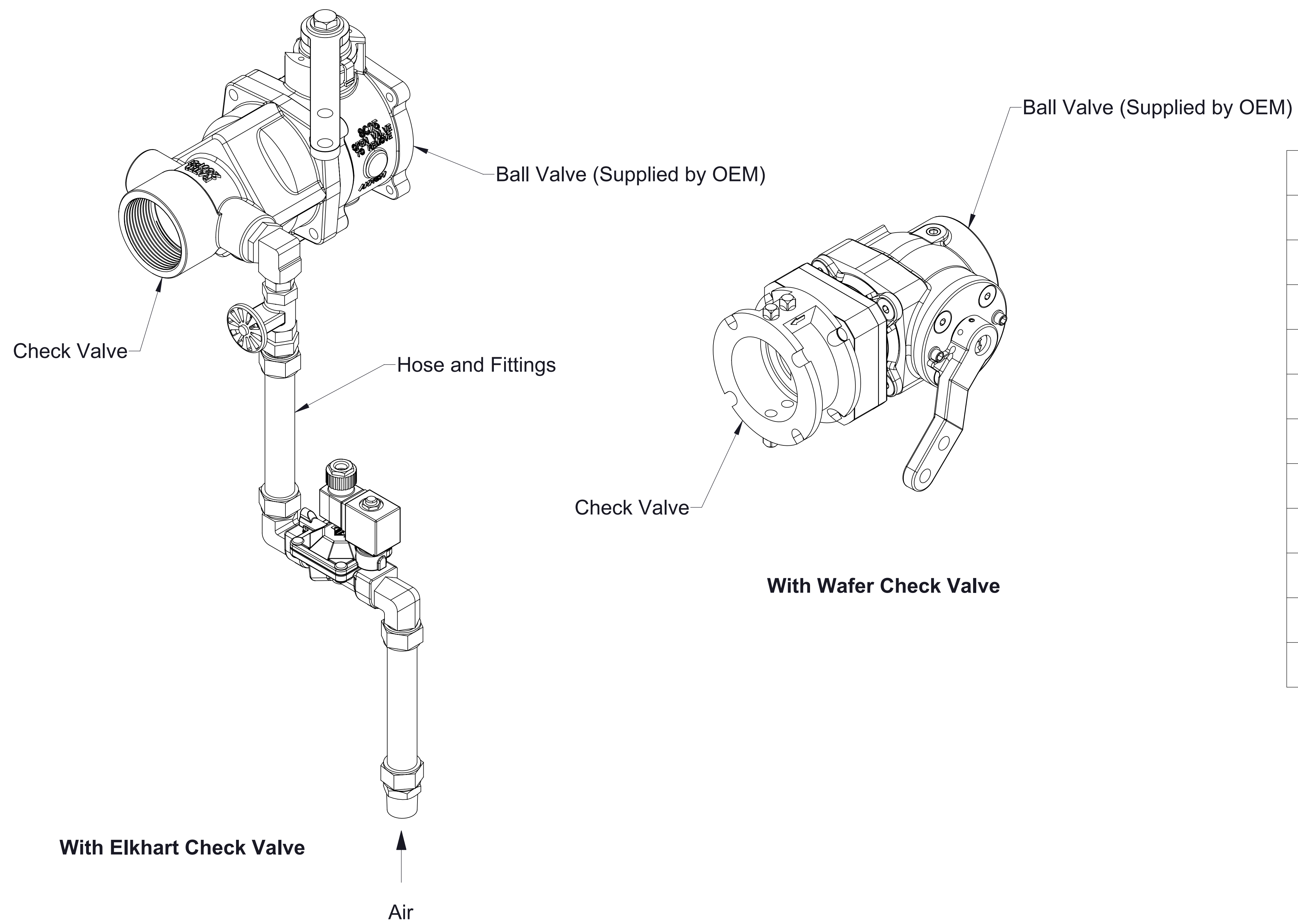

Components:	See Page
Elkhart Check Valves	
1.5 in	2
2.0 in	3
2.5 in	4
Wafer Check Valves	
2.0 and 2.5 in	5
Optional Air Valves	
Electric	6
Manual	6
Electric Air Valve Wiring	6
Hose and Fittings	7

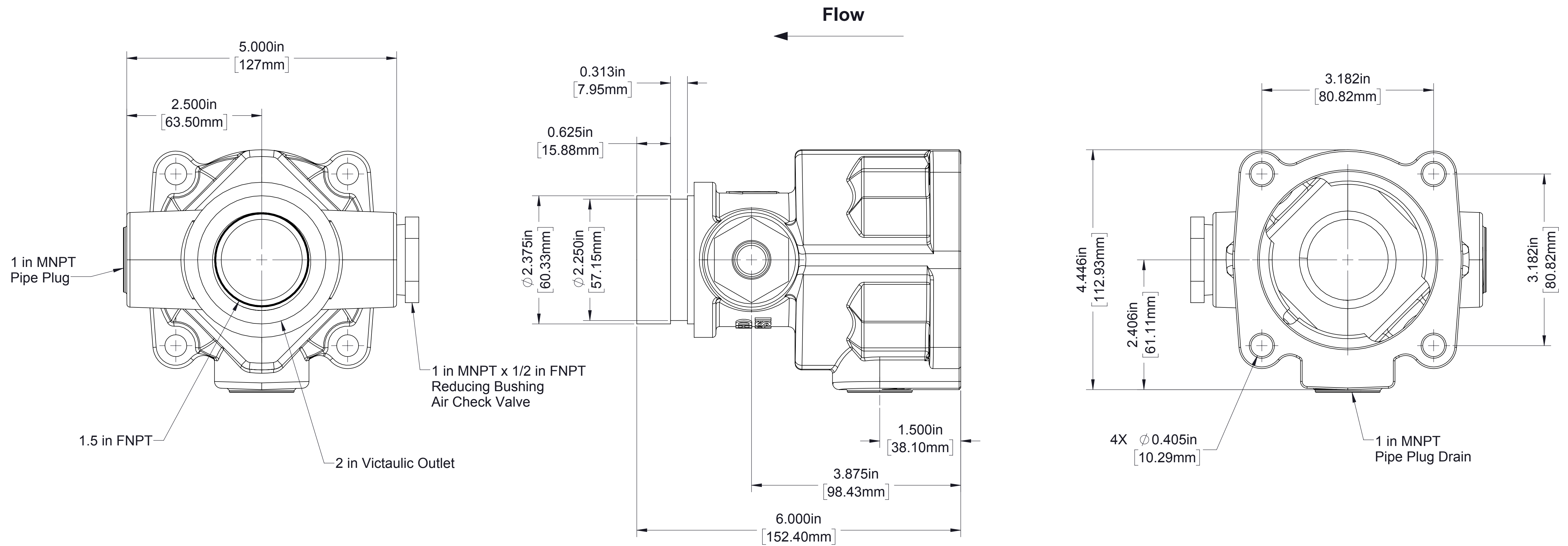

Note:
1. 1.5 in valve has both Victaulic and FNPT on outlet.

Elkhart 1.5 in Check Valve

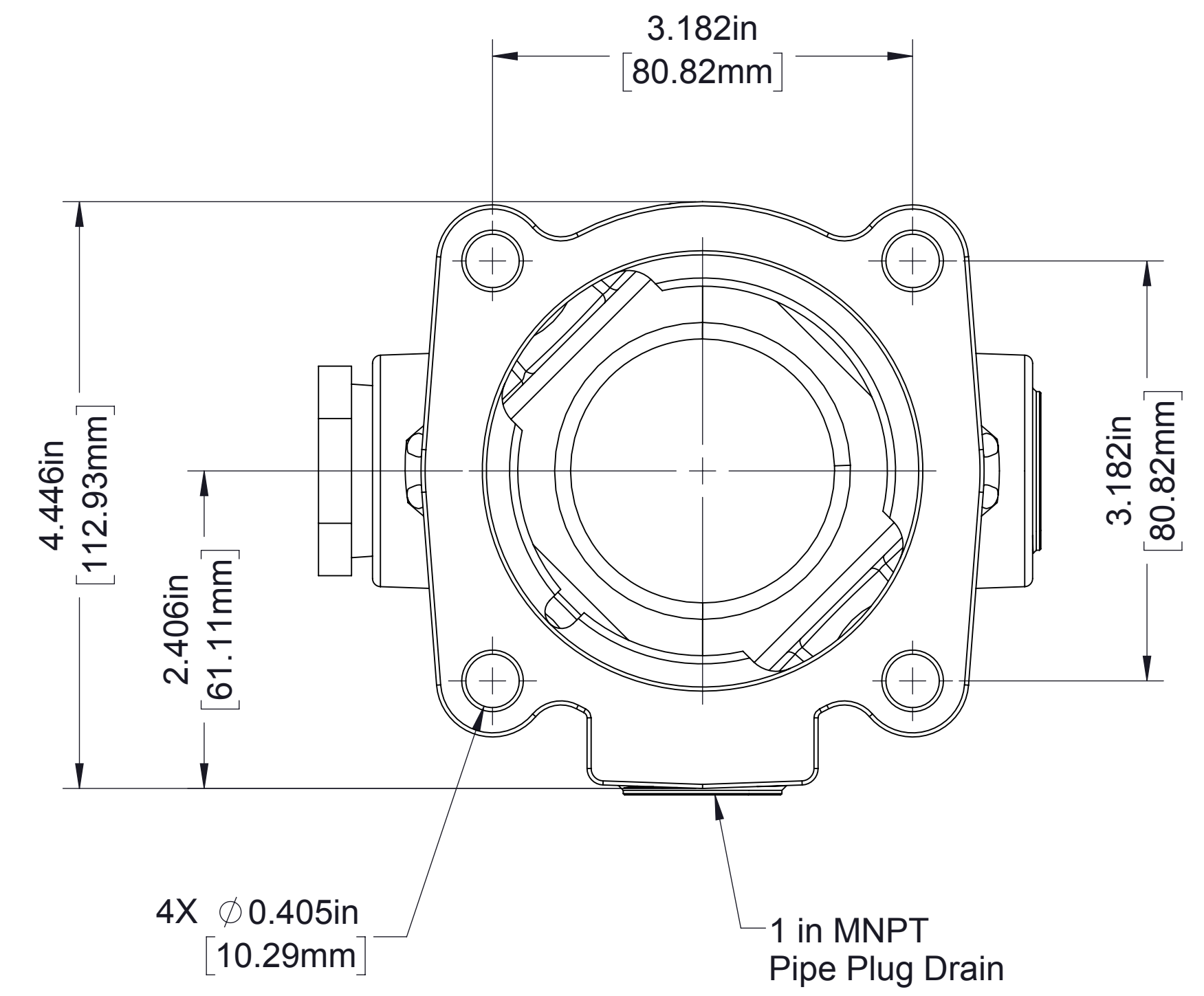
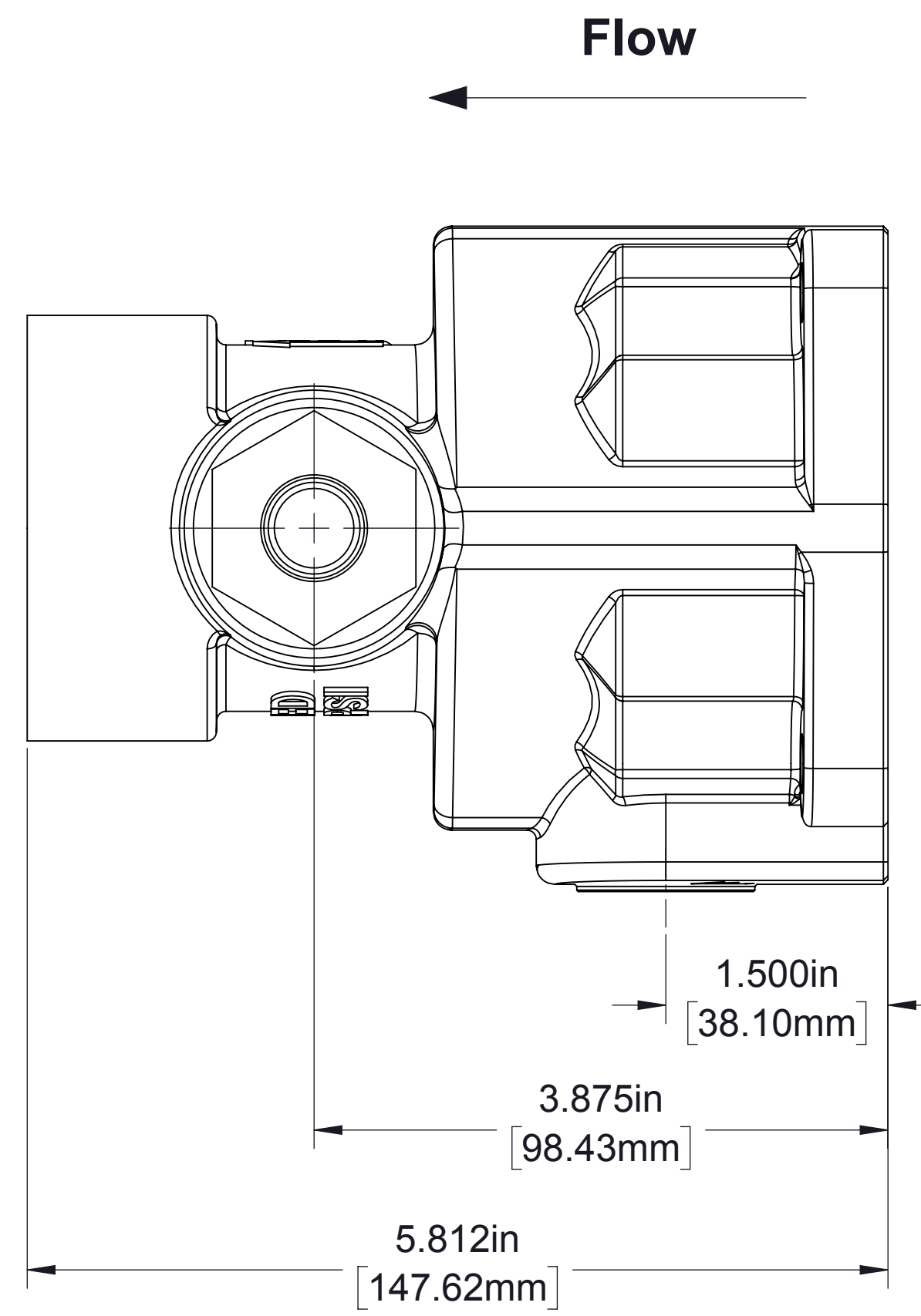
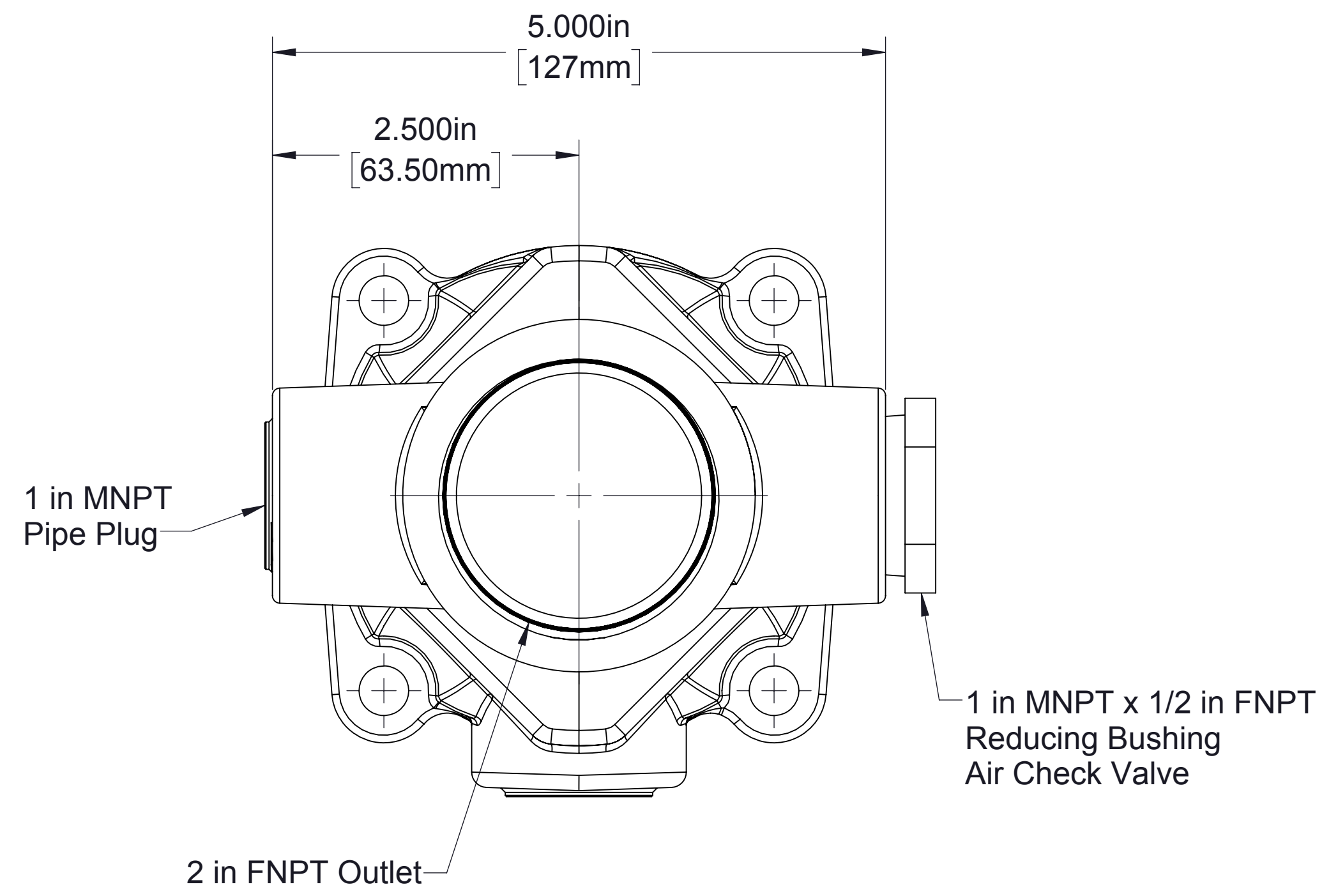

2.0 in FNPT Outlet

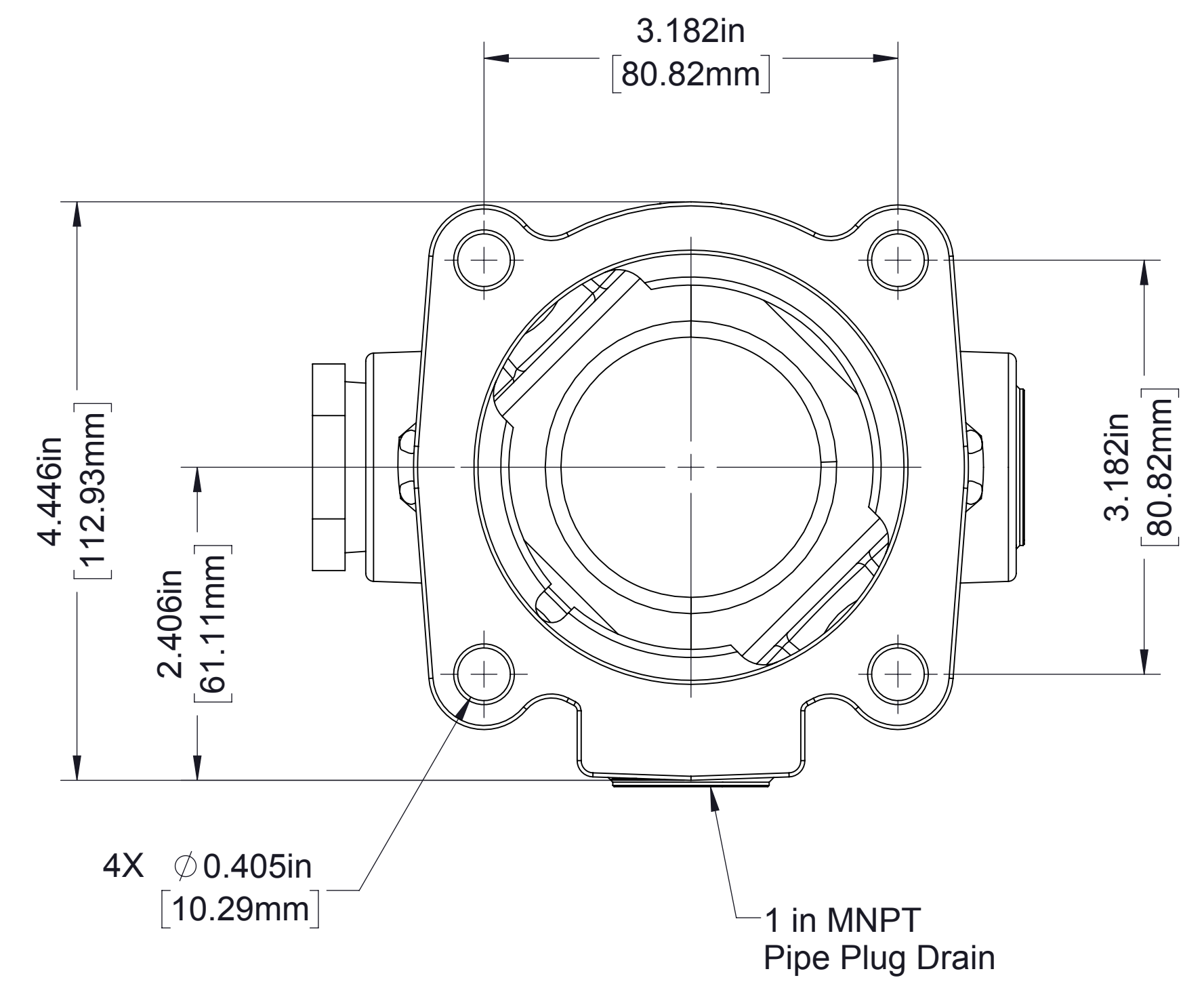
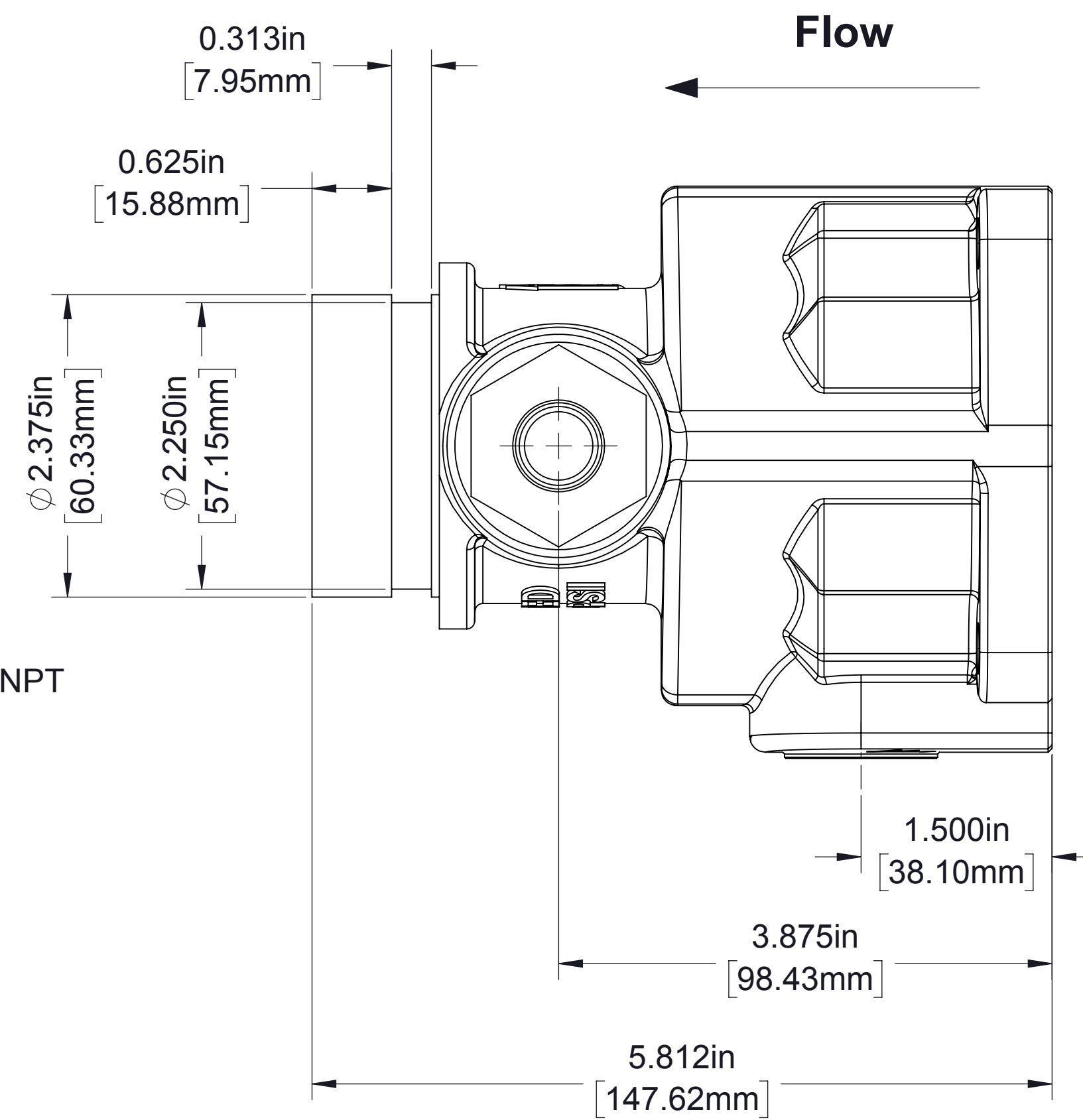
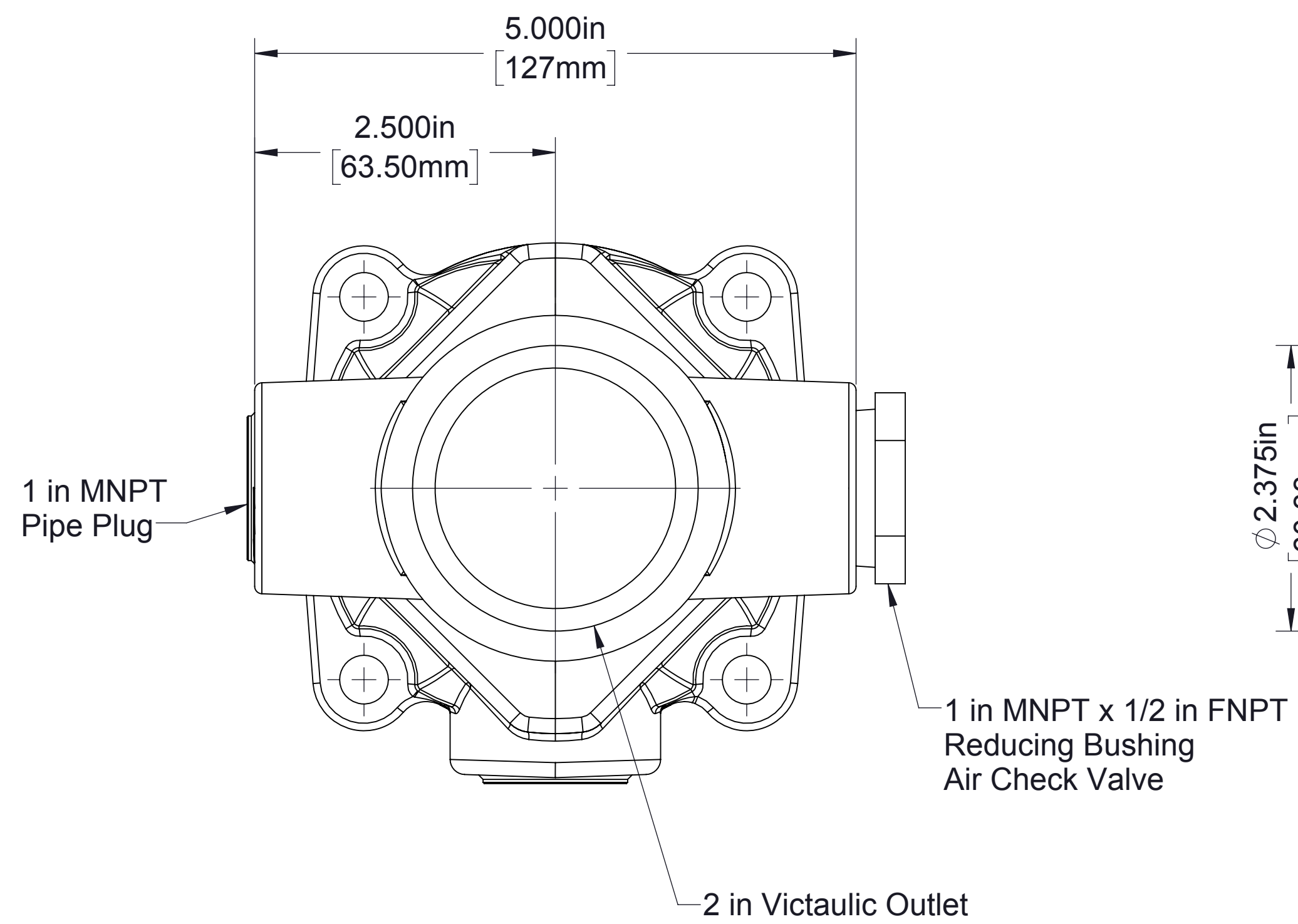

2.0 in Victaulic Outlet

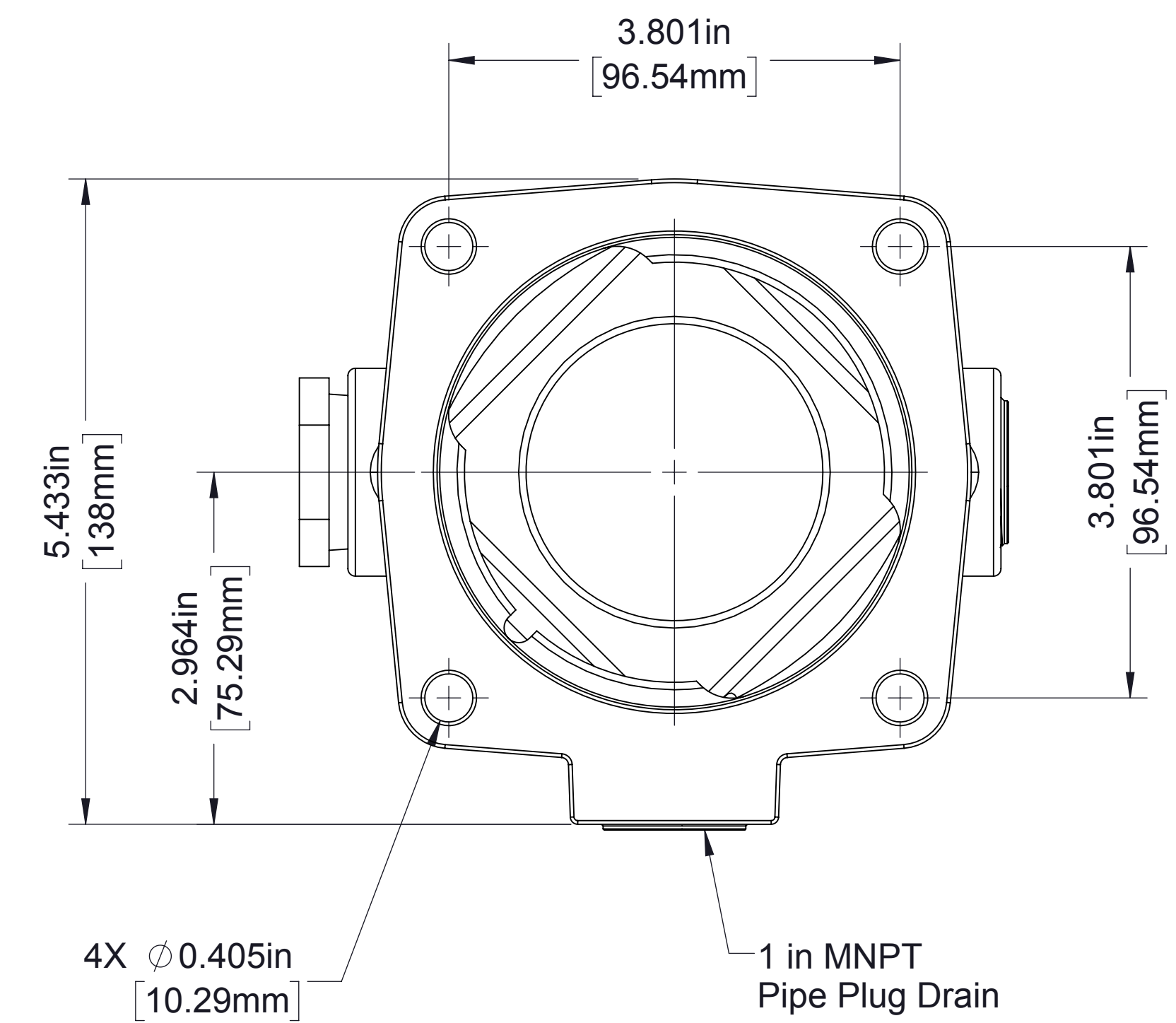
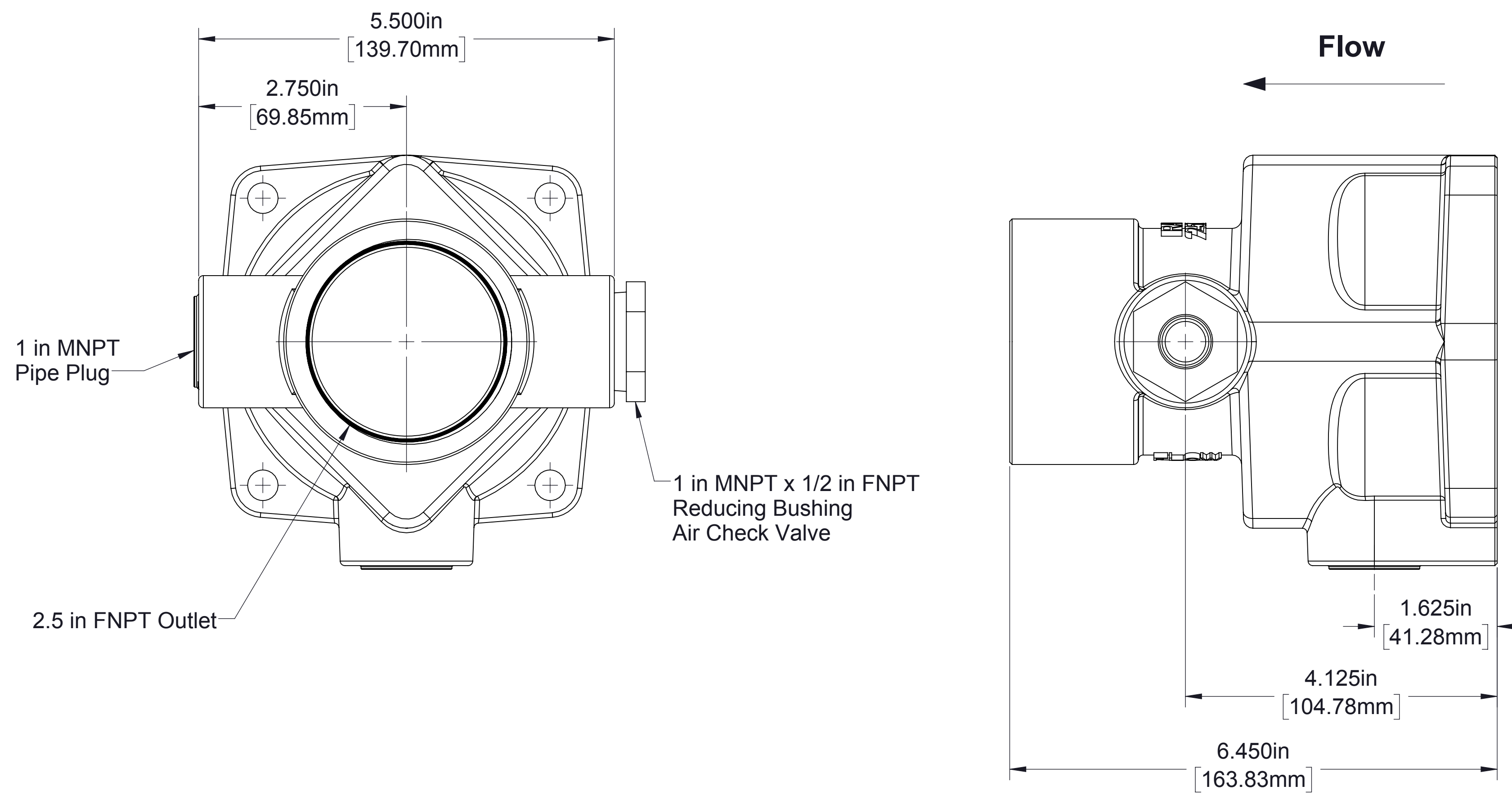

2.5 in FNPT Outlet

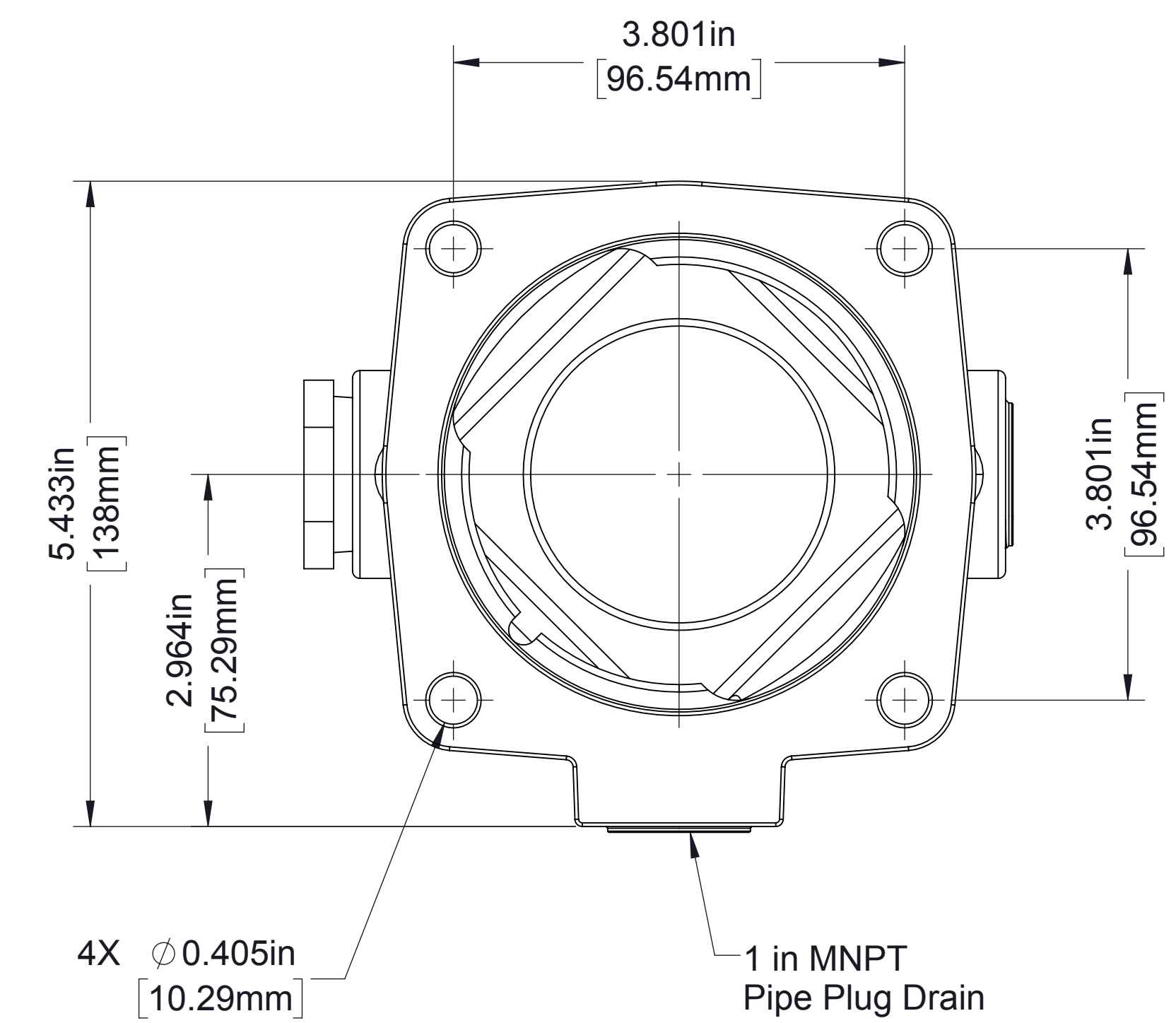
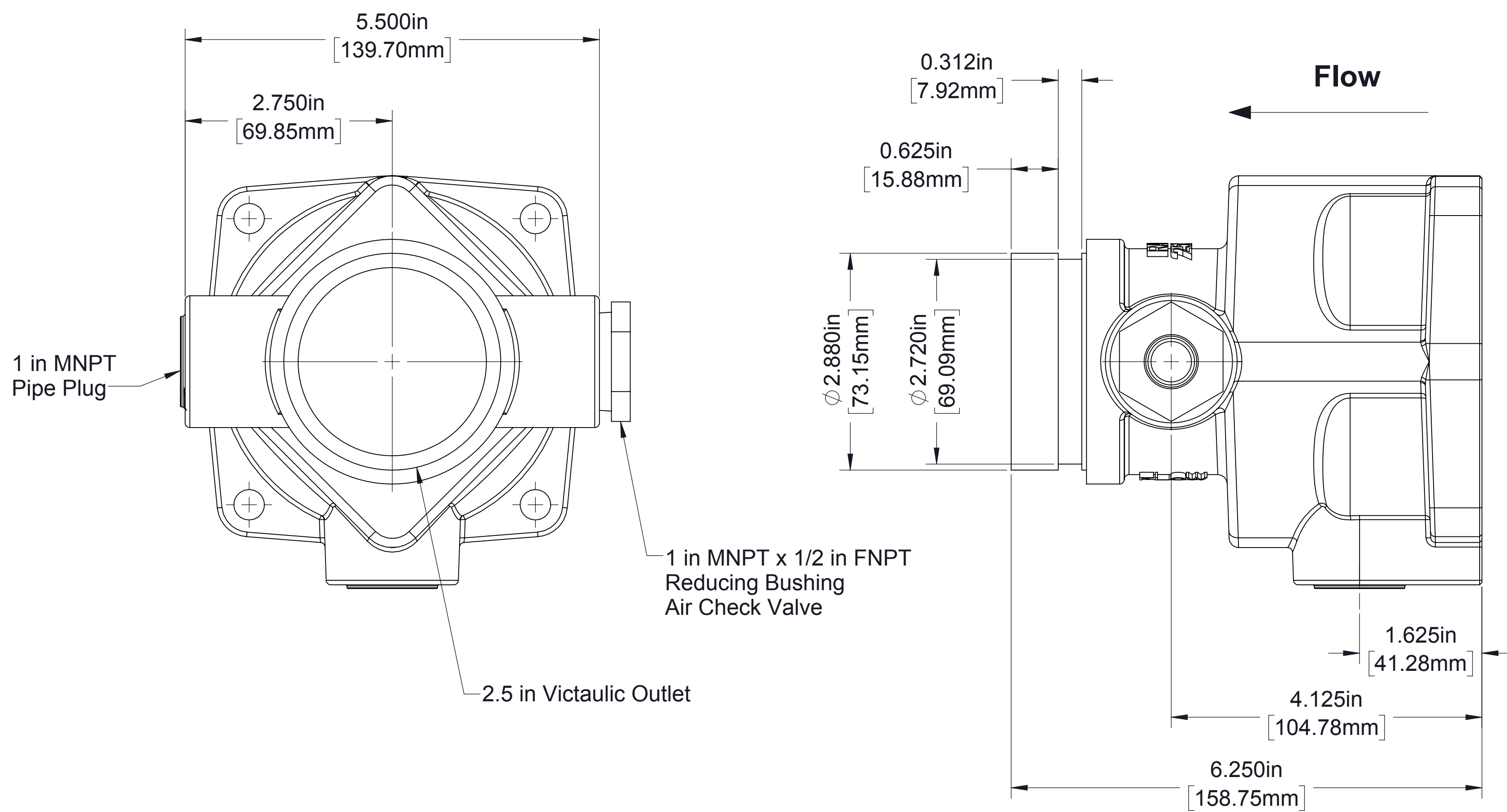

2.5 in Victaulic Outlet

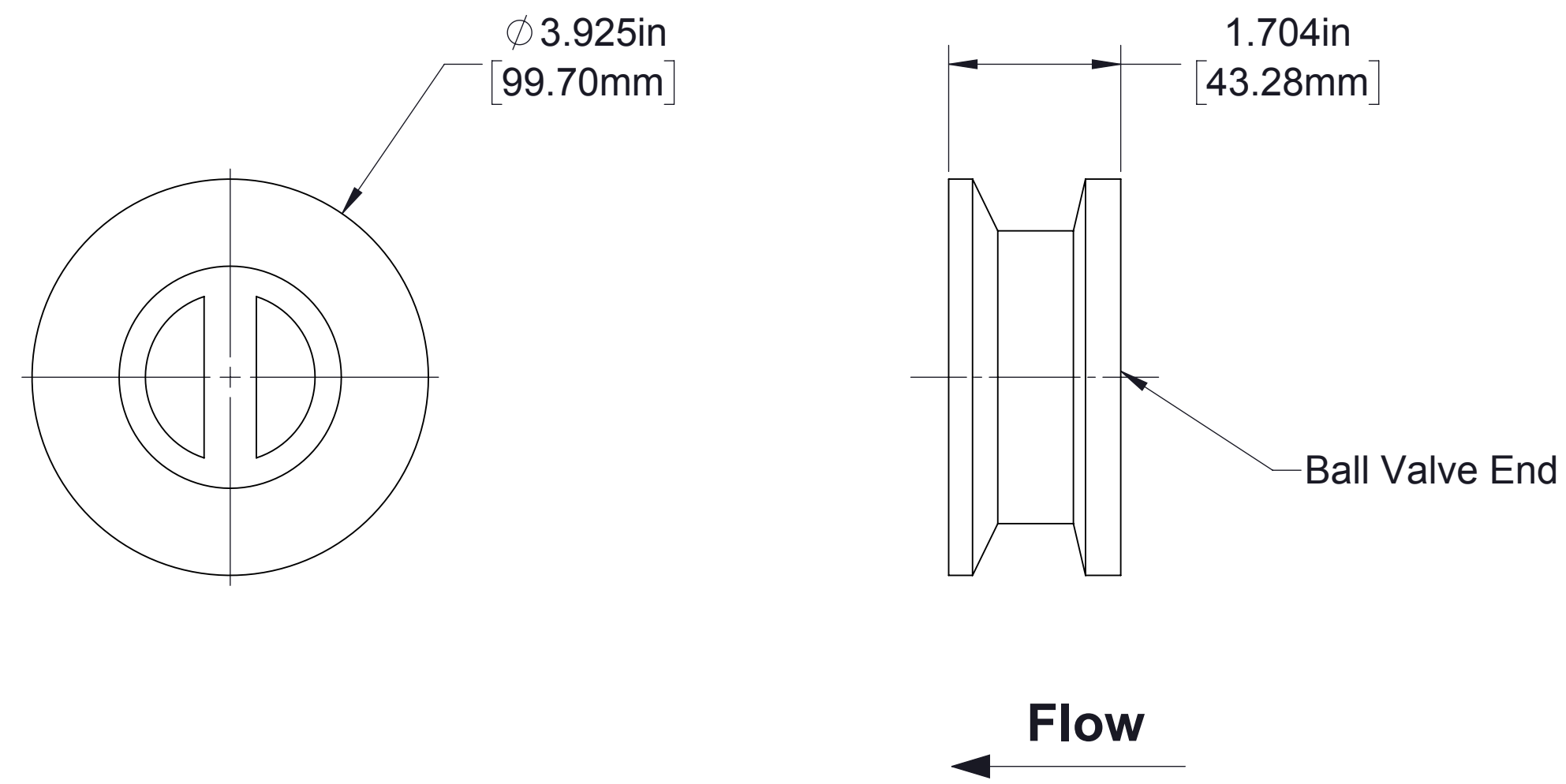

2.0 in Wafer Check Valve

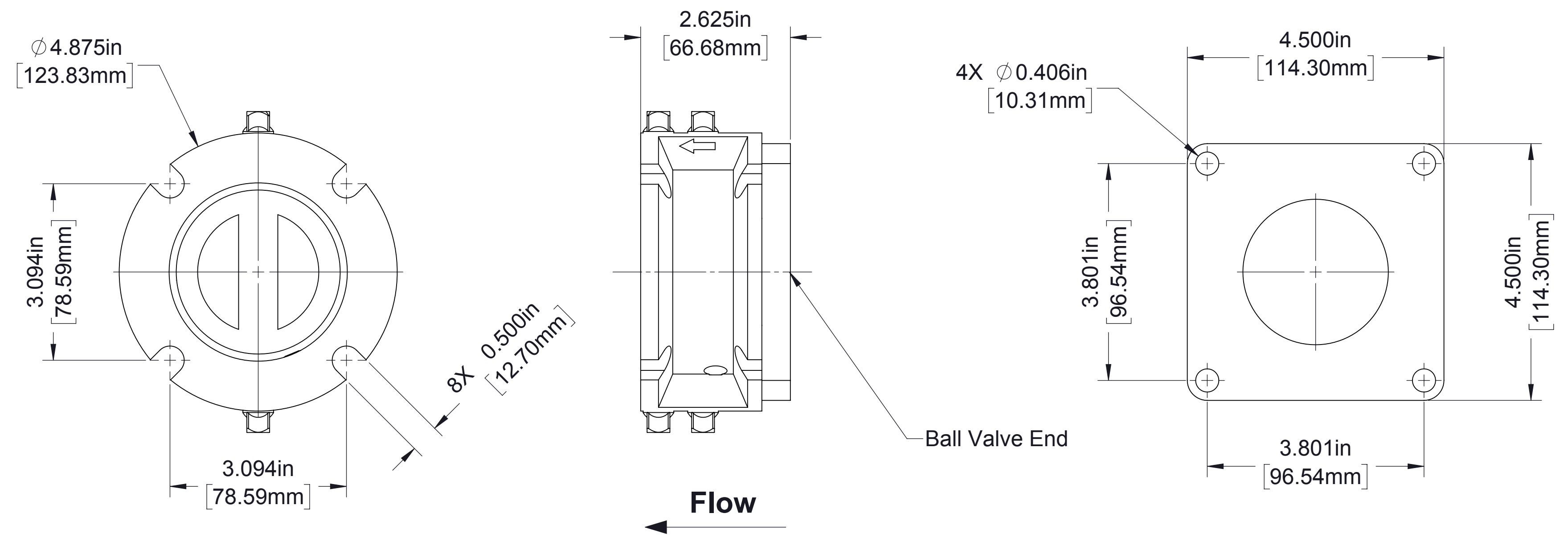

**2.5 in Wafer Check Valve
Used with Elkhart Ball Valves**

Note:
Air line is to be installed downstream of check valve in OEM supplied piping.

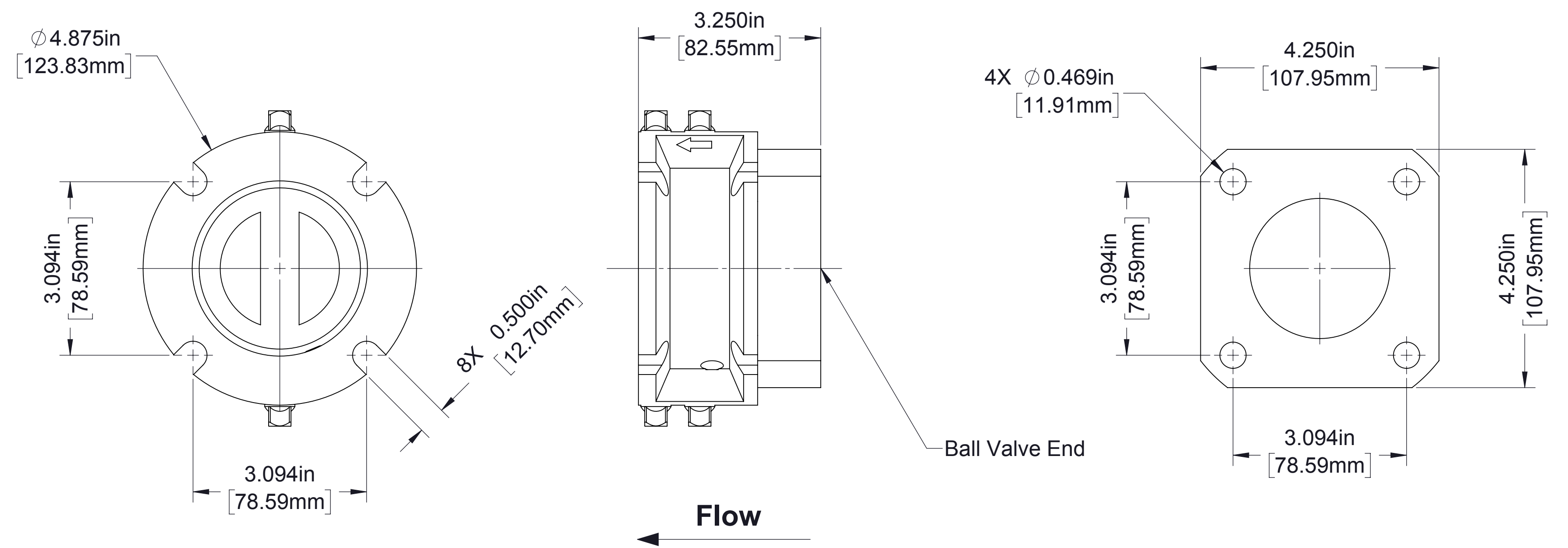

**2.5 in Wafer Check Valve
Used with Waterous 2.5 in Ball Valves or Waterous 2.5 in 4-Bolt Flanges**

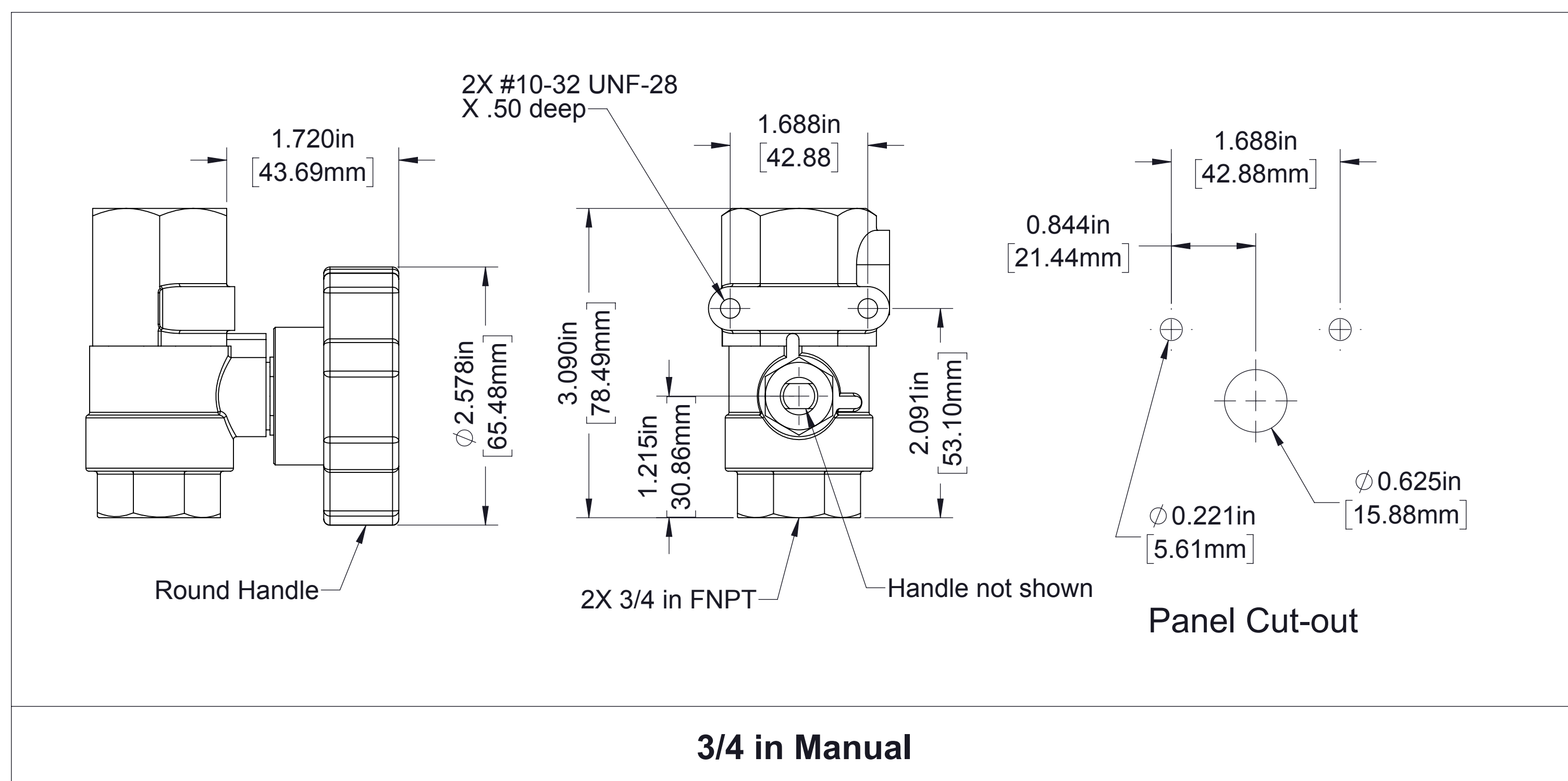
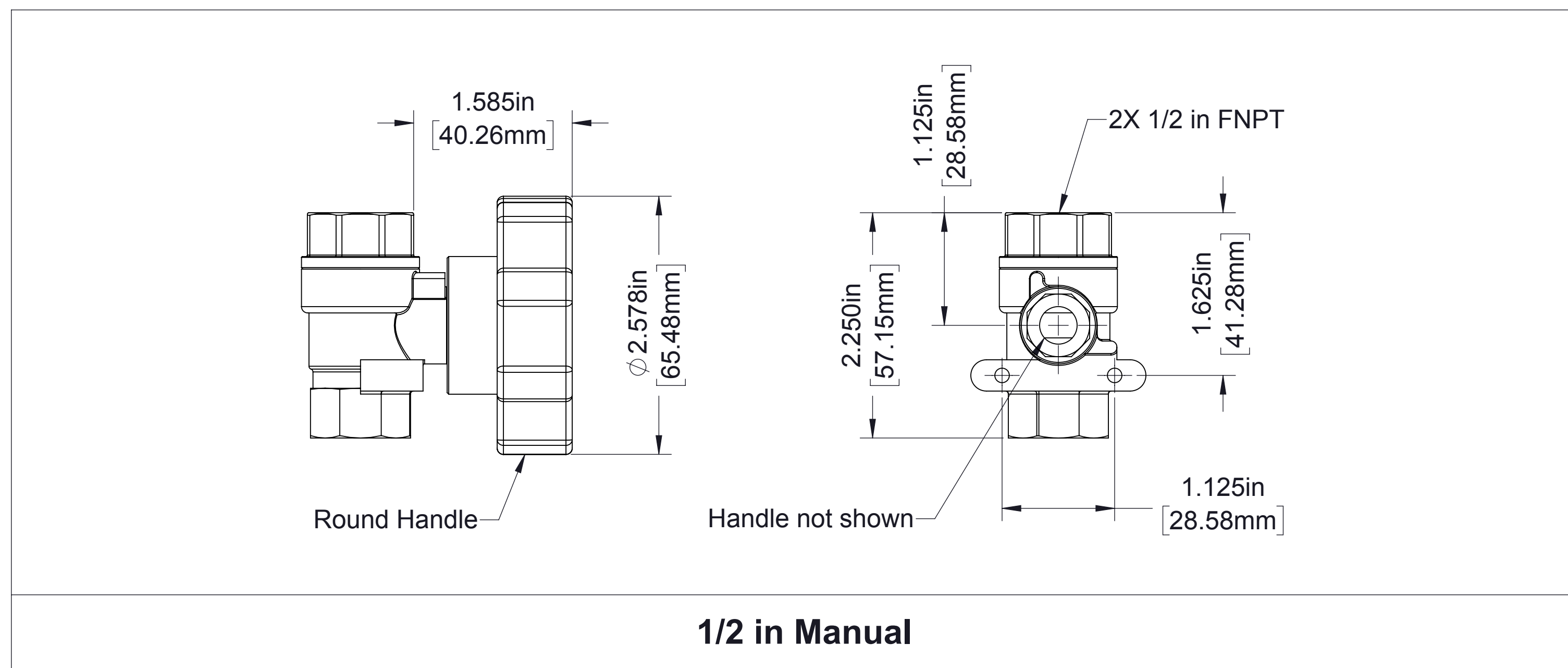
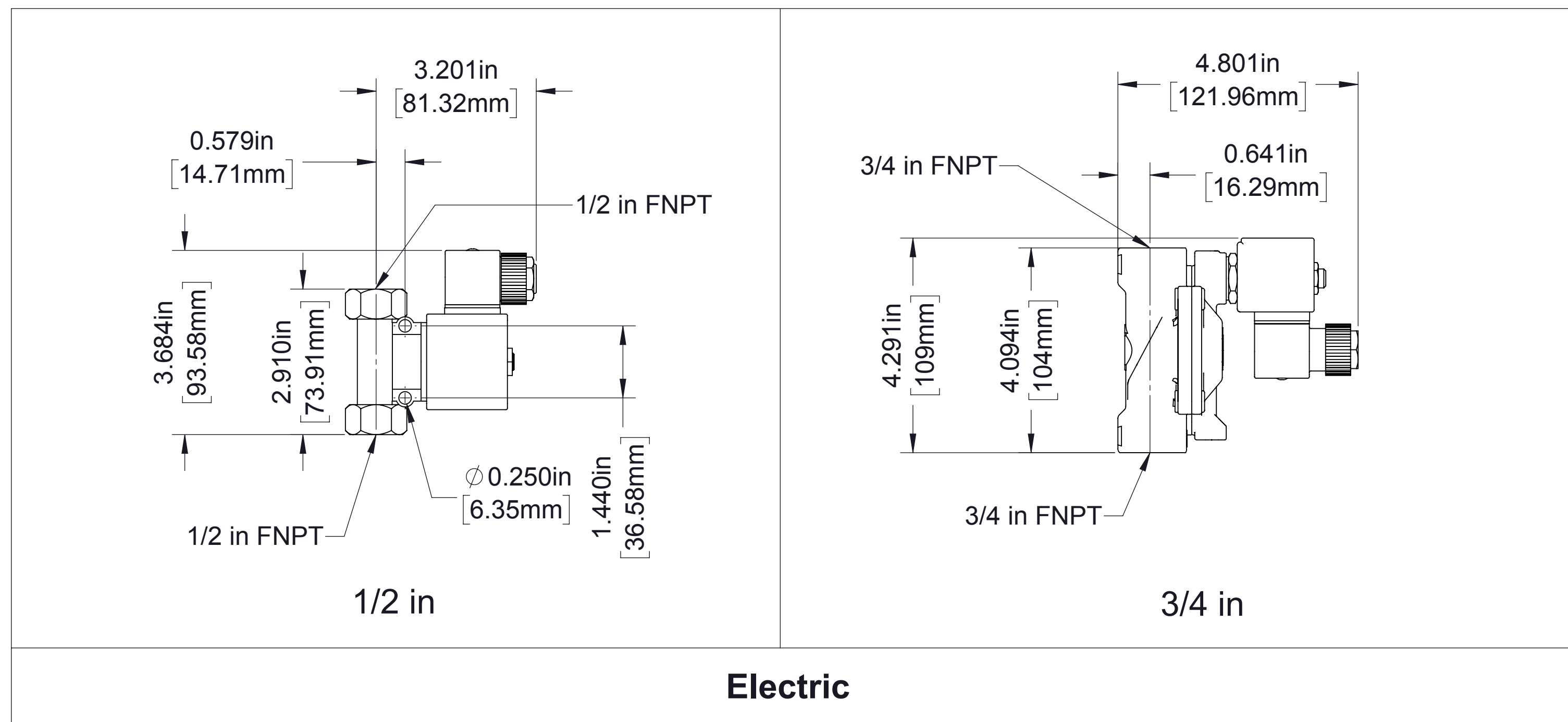

Optional Air Valves

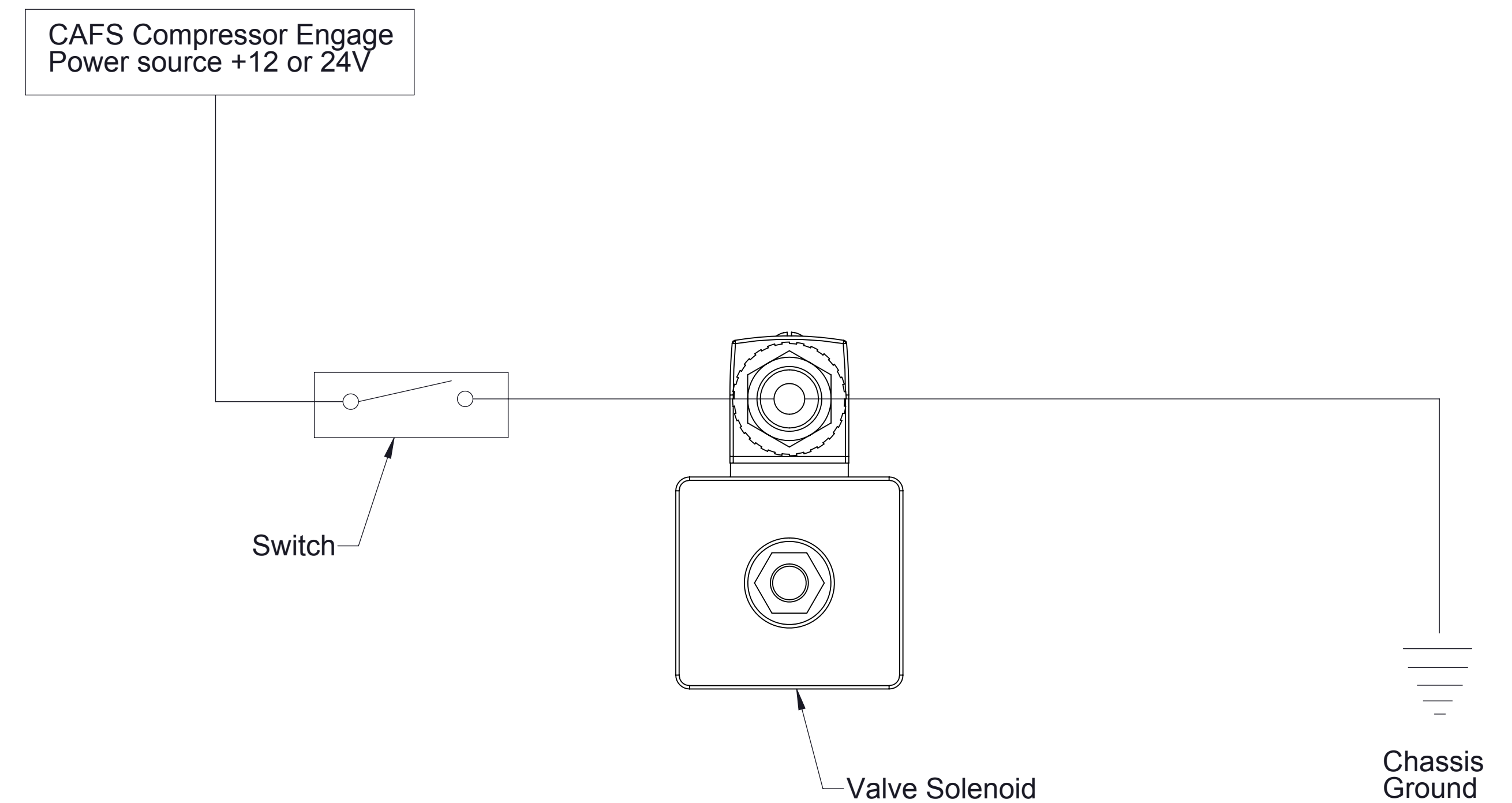

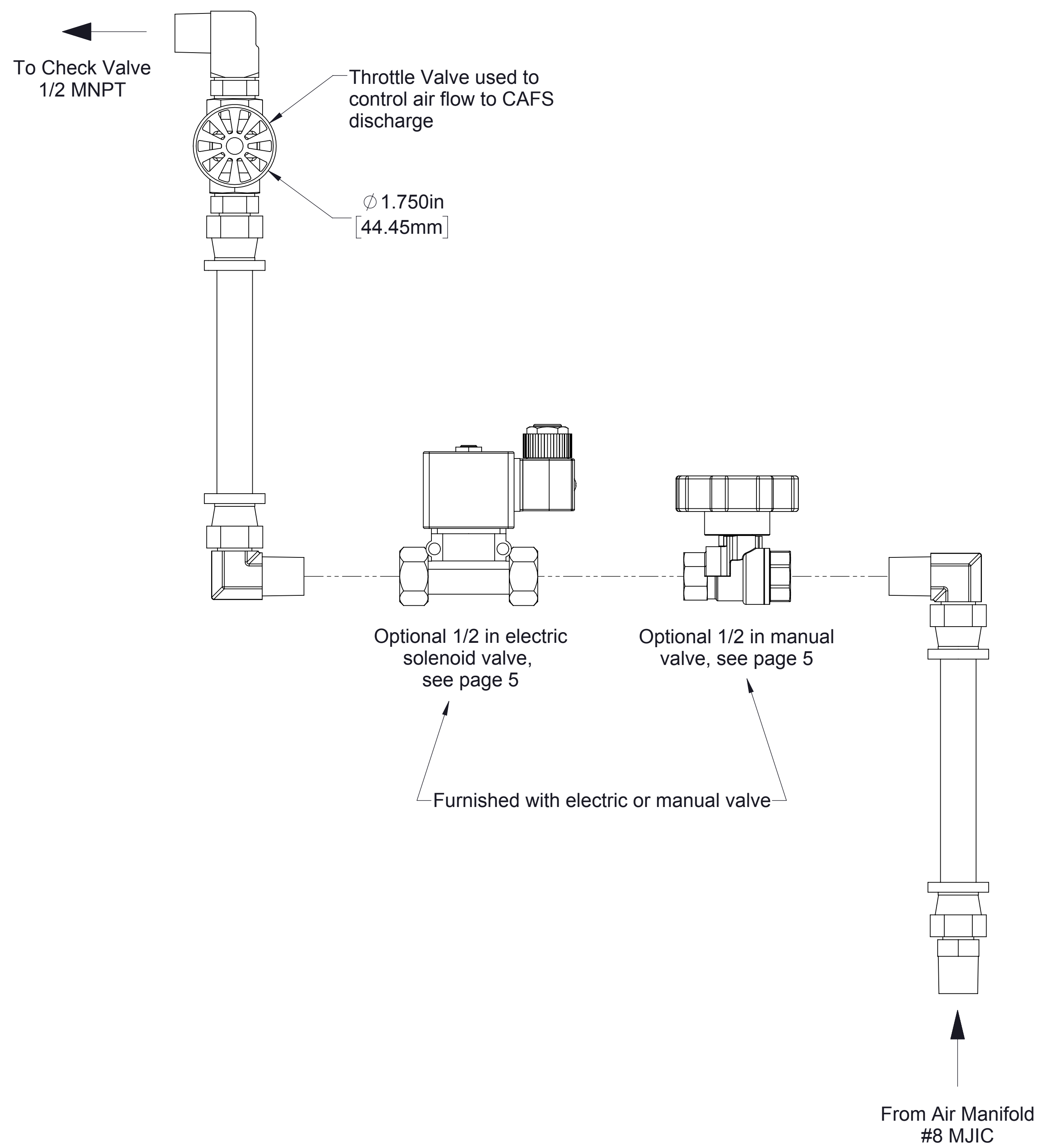

1.5 in or 2.0 in check valve hose and fittings, 1/2 in valve, fittings and hose furnished

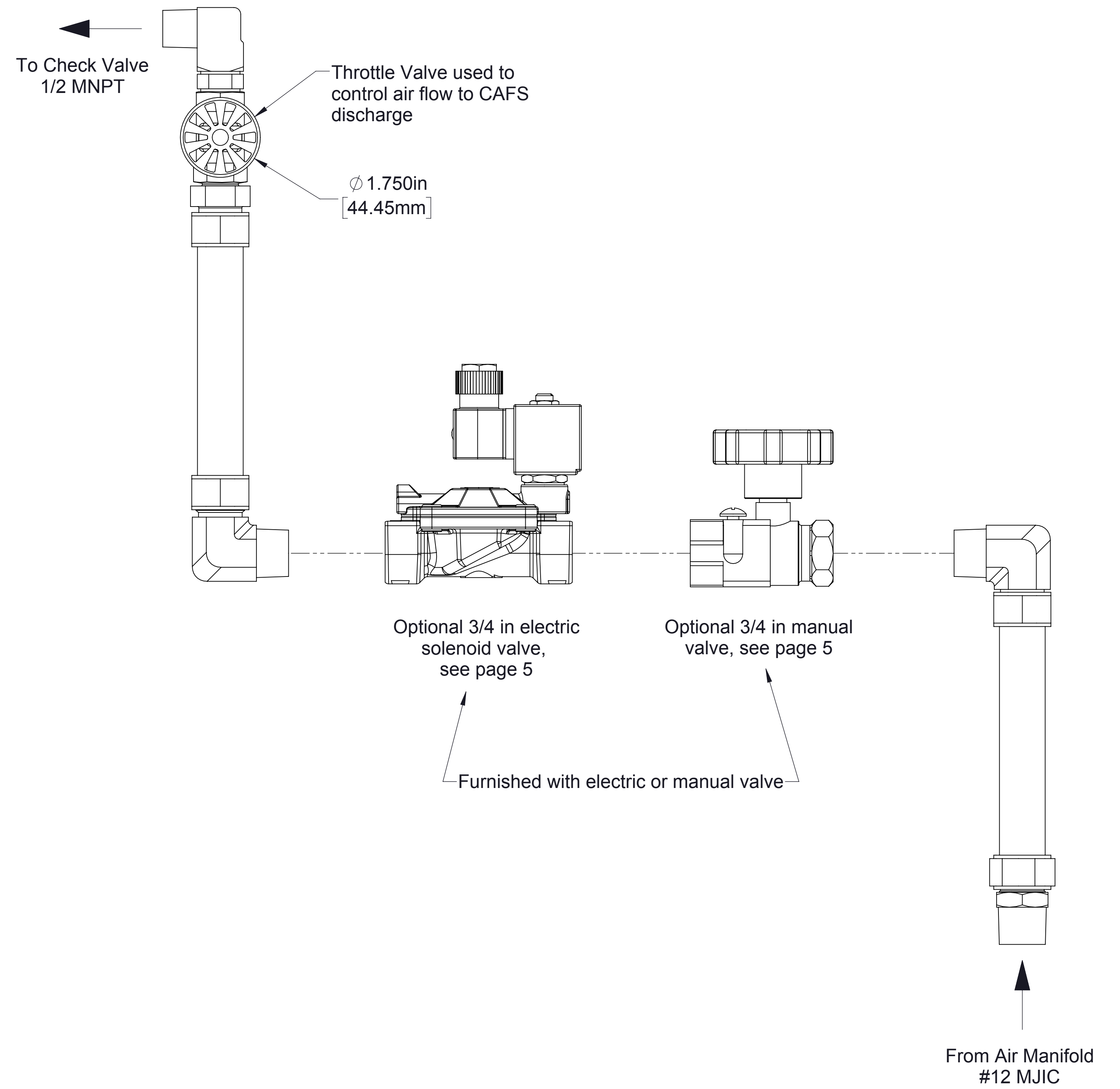

2.5 in check valve hose and fittings, 3/4 in valve, fittings and hose furnished

**Hose and Fittings
10 foot/3.04 meter length of
hose furnished with each valve**