

Foam System Dimensional Drawings Models Aquis 2.5 and Aquis 2.5 SSP Traditional CAFS

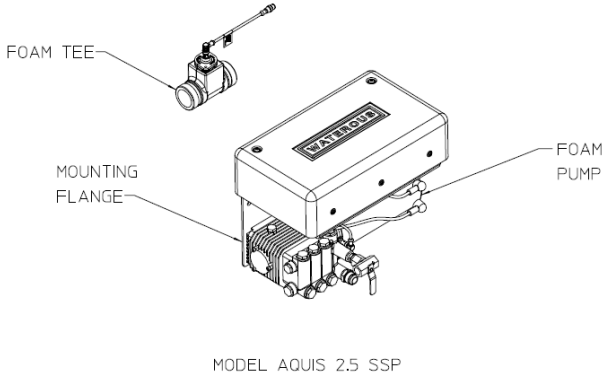

	Page
System Schematic	2
Standard Components:	
Foam Pump:	
Aquis 2.5	3
Aquis 2.5 SSP.....	4
OIT (Operator Interface Terminal):	
Digital (Standard)	5
V-MUX (Optional).....	5
Foam Inject Check Valve.....	5
Foam Line Strainer.....	5
Foam Tee (Includes Flowmeter)	6
Optional Components:	
Panel Plates	7
Foam Tank Level Switch	7
Cable Extensions:	
OIT.....	5
Flowmeter	6
Foam Tank Level Switch	7
Panel Mounted Foam Line Strainer	8
Dual OIT Kit.....	9
Foam Supply Hose Kit	10
Foam Inject/Bypass Hose Kit	10
Foam Pick Up Hose:	
Hoses Only	11
Overboard Foam Pick Up Kit	See DPL83493
Master Waterway Check Valve	See DPL83485
FoamFill System.....	See DPL83460
Remote System Activation Module ..	See DPL83495
Dual Foam Injection Kit	See DPL83508
Electrical Connections:	
Foam Tank Level Switch	7
Foam Pump Power	11

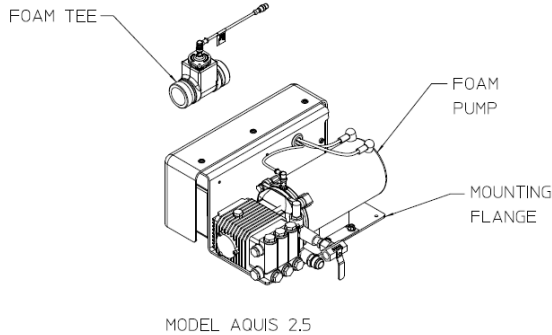

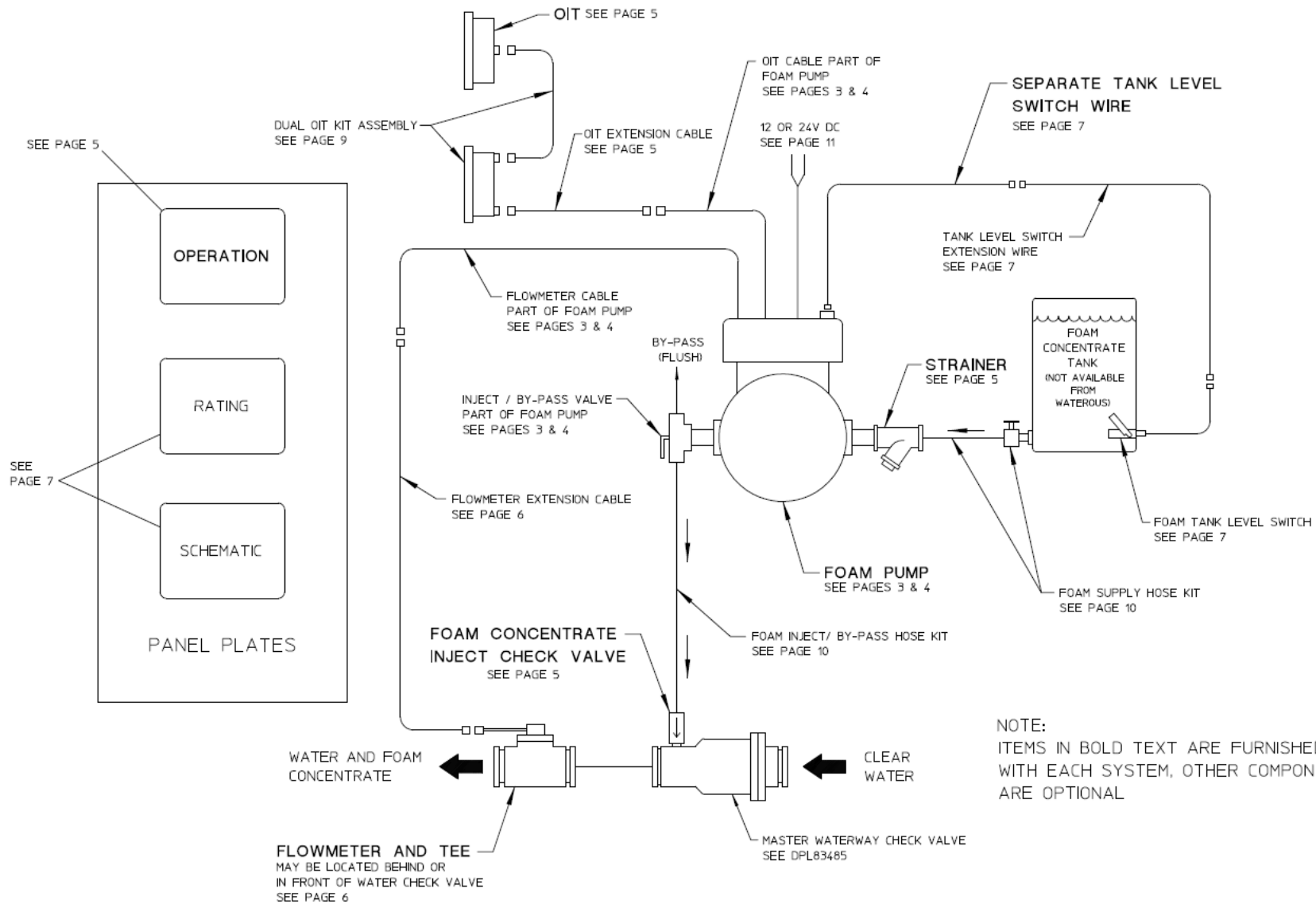
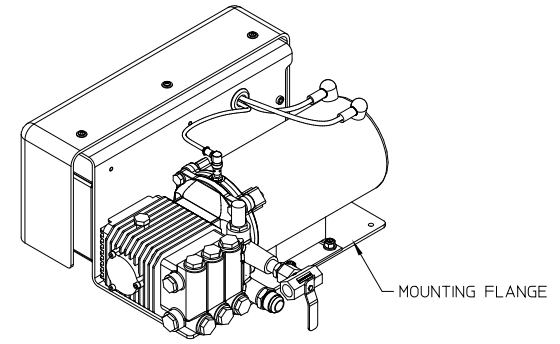
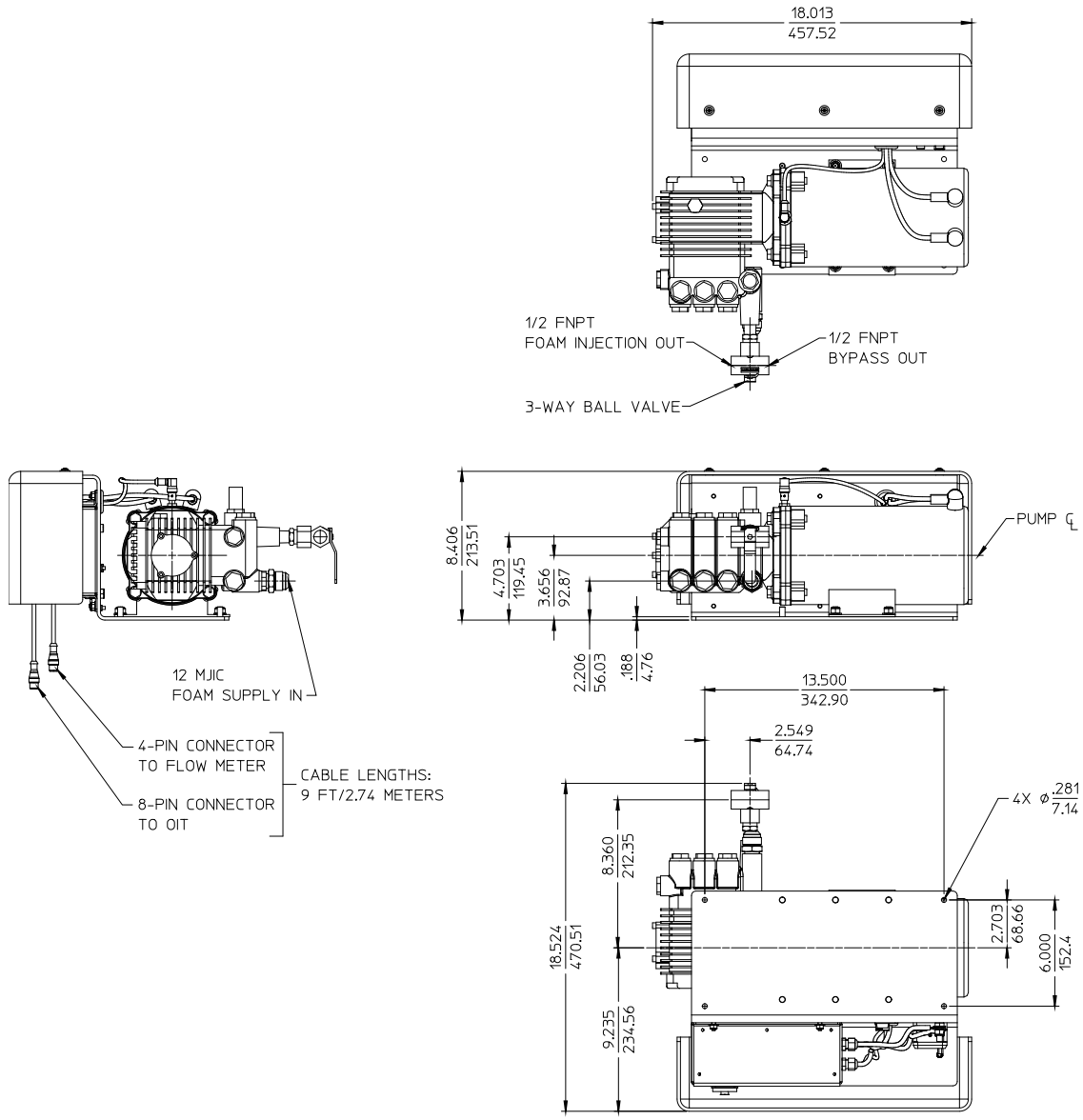

ALL DIMENSIONS SHOWN AS INCH/MILLIMETER
(INCH / MILLIMETER)

FOAM PUMP MODEL - AQUIS 2.5

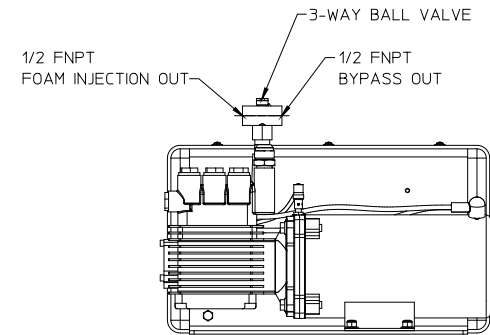
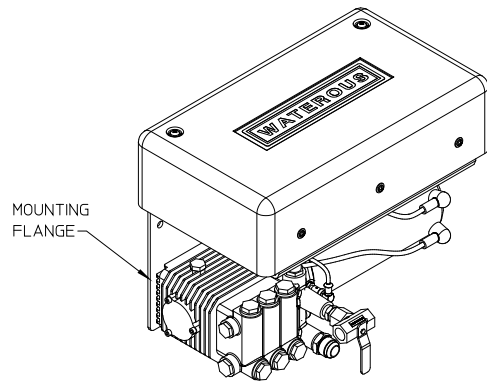
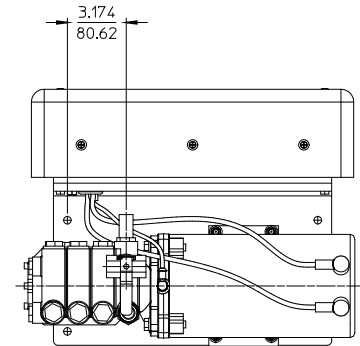
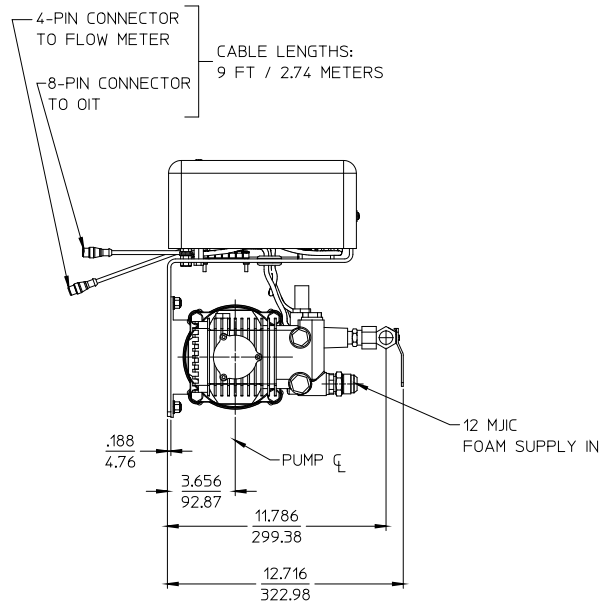
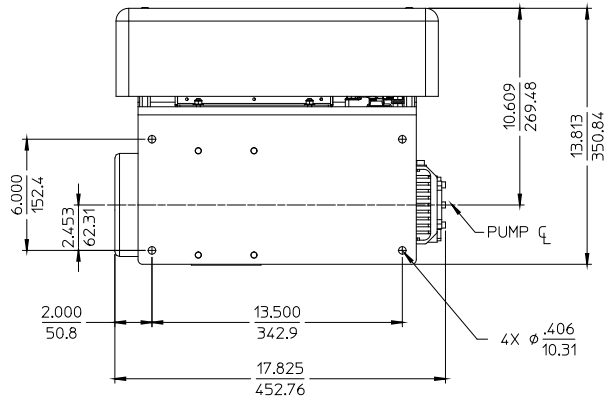

ALL DIMENSIONS SHOWN AS INCH/MILLIMETER
(INCH)
(MILLIMETER)

FOAM PUMP MODEL - AQUIS 2.5 SSP

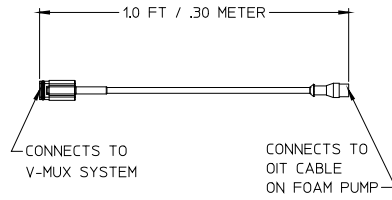

NOTE: OIT AND INSTRUCTION PLATE
ARE NOT FURNISHED.
V-MUX SYSTEM CONTROLS FOAM PUMP

V-MUX (OPTIONAL)

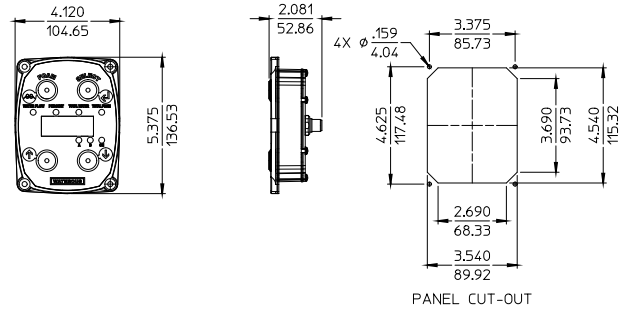

DIGITAL (STANDARD)

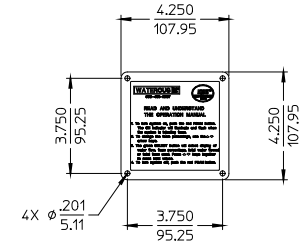

SEPARATE INSTRUCTION
PANEL PLATE

OIT (OPERATORS INTERFACE TERMINAL)
AVAILABLE CABLE EXTENSIONS:
9.8 FT / 3 METERS - ORDER PART NO. Q-4310006
19.6 FT / 6 METERS - ORDER PART NO. Q-4310007

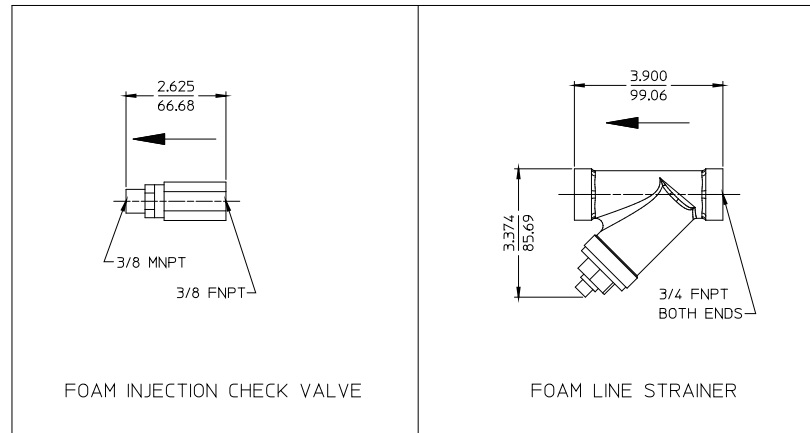

ALL DIMENSIONS SHOWN AS INCH/MILLIMETER
(INCH)
(MILLIMETER)

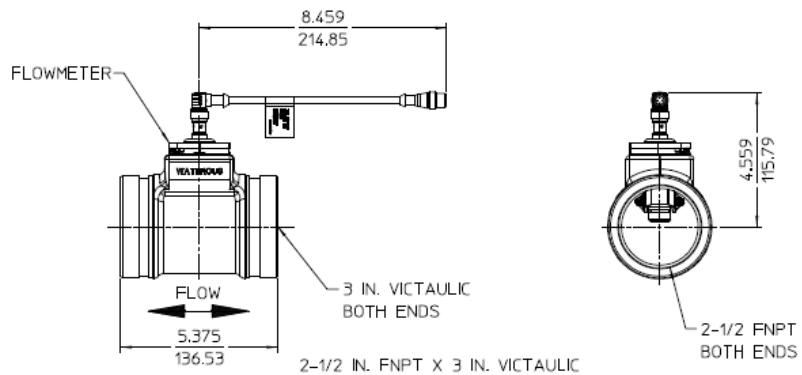
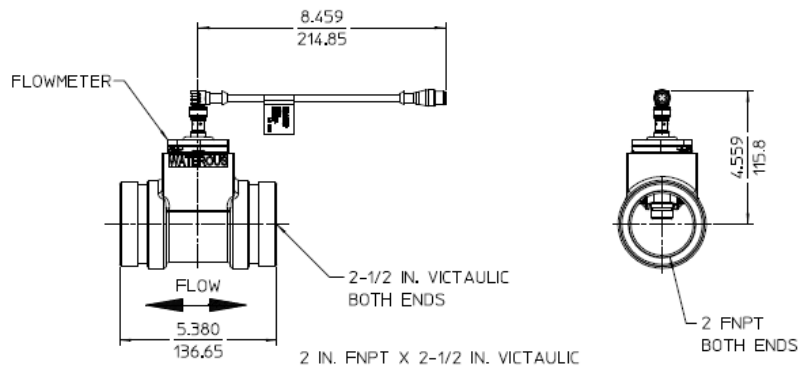
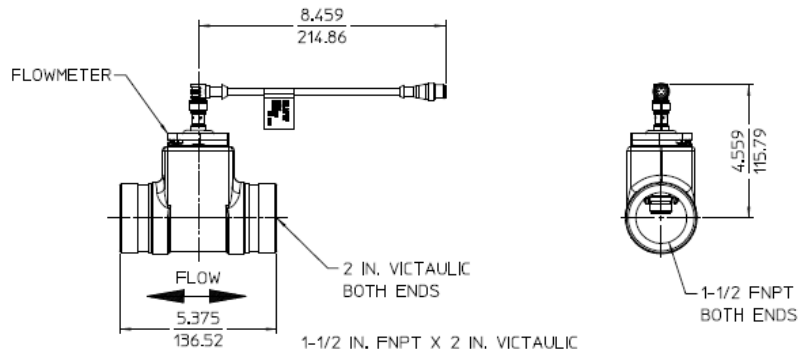

FOAM TEE (INCLUDES FLOW METER)
 AVAILABLE CABLE EXTENSION:
 13.1 FT / 4 METERS - ORDER PART NO. Q-4130017

ALL DIMENSIONS SHOWN AS INCH/MILLIMETER
 (INCH)
 (MILLIMETER)

ORDER PART NO'S:
 Q-0315321 (ENGLISH)
 63752 (CHINESE)

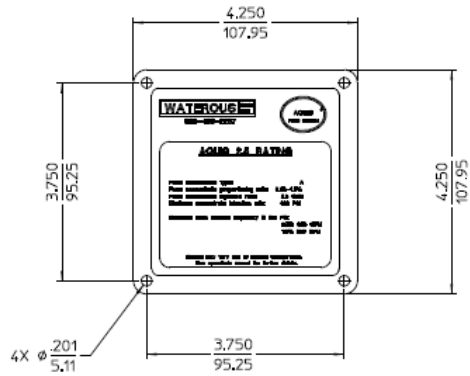

OPTIONAL RATING PANEL PLATE

ORDER PART NO'S:
 Q-0315315 (ENGLISH)
 63756 (CHINESE)

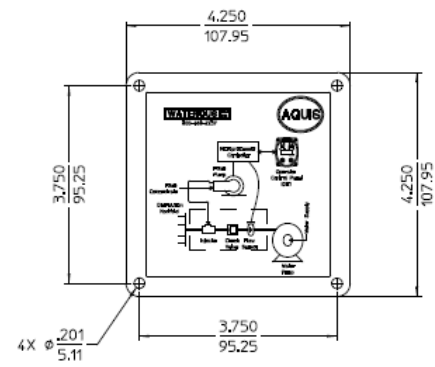

OPTIONAL SCHEMATIC PANEL PLATE

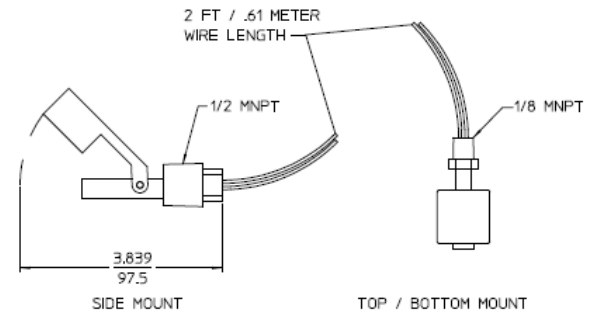
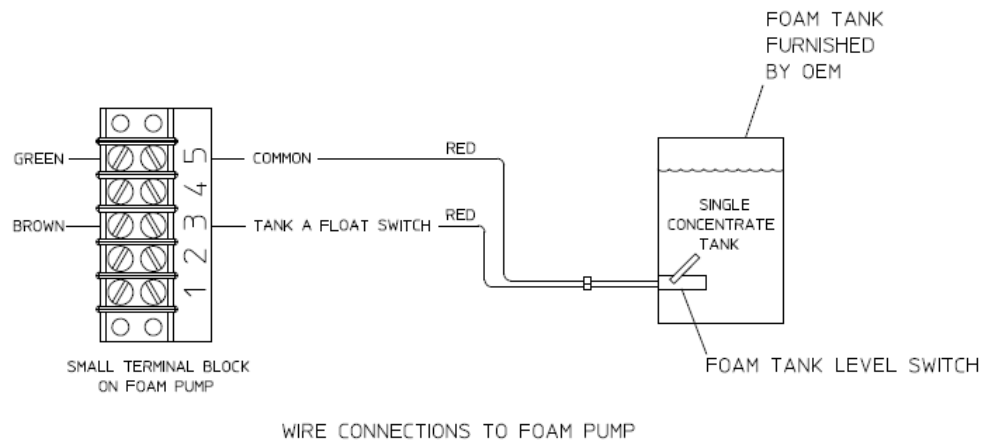

OPTIONAL FOAM LEVEL TANK SWITCH

ORDER PART NO'S:
 Q-4190000 (SIDE MOUNT)
 Q-4190001 (TOP/BOTTOM MOUNT)

AVAILABLE WIRE EXTENSION:
 13.1 FT / 4 METERS - ORDER PART NO. Q-4310014

ALL DIMENSIONS SHOWN AS INCH/MILLIMETER
 (INCH / MILLIMETER)

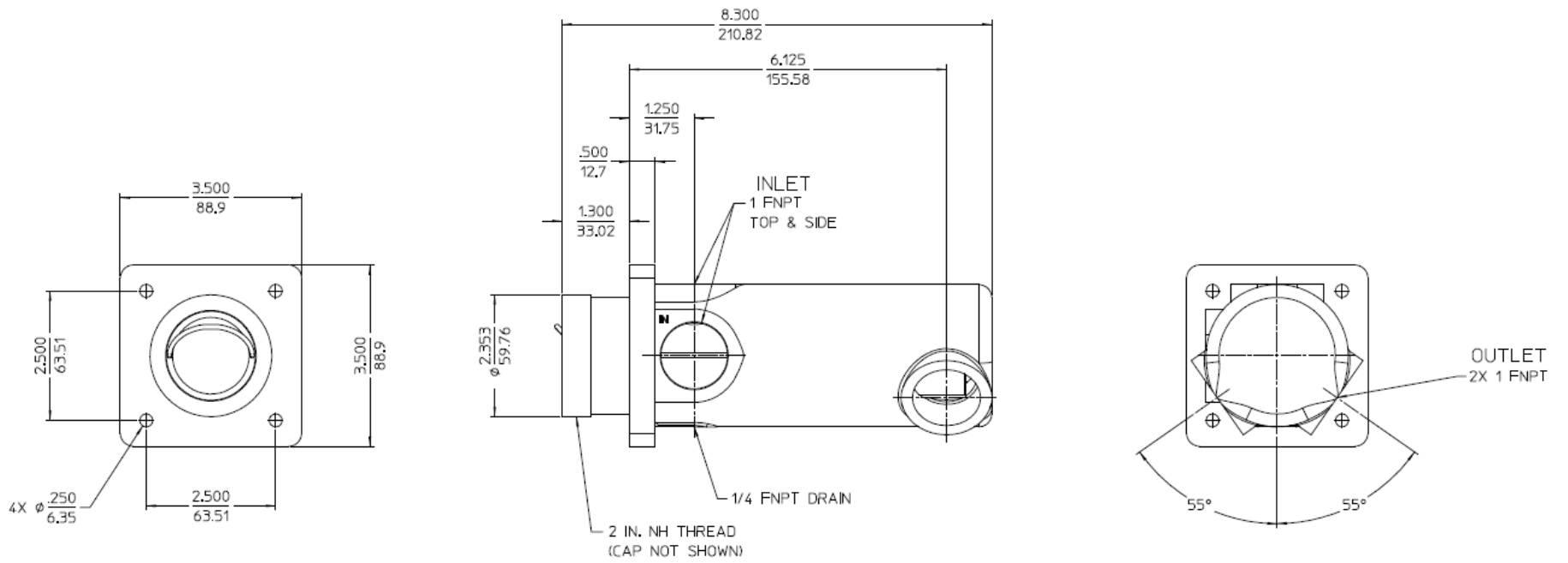

OPTIONAL PANEL MOUNTED FOAM LINE STRAINER

NO. 10 MESH, INCLUDES CAP AND CHAIN
ORDER PART NO. Q-2450011

ALL DIMENSIONS SHOWN AS INCH/MILLIMETER
(INCH
MILLIMETER)

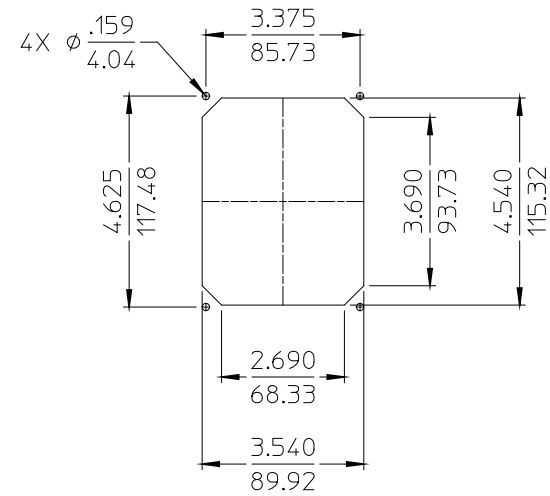
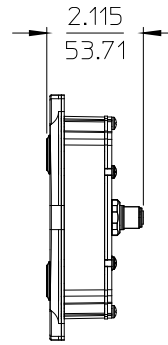
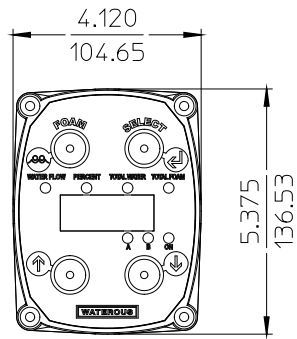

INCLUDES 19.6 FT / 6 METER CABLE

PANEL CUT-OUT

DIGITAL

ORDER PART NO.
83459-1B (ENGLISH)
83459-2B (CHINESE)

OPTIONAL DUAL OIT KIT

AVAILABLE CABLE EXTENSIONS:
9.8 FT / 3 METERS - ORDER PART NO. Q-4310006
19.6 FT / 6 METERS - ORDER PART NO. Q-4310007

ALL DIMENSIONS SHOWN AS INCH/MILLIMETER
($\frac{\text{INCH}}{\text{MILLIMETER}}$)

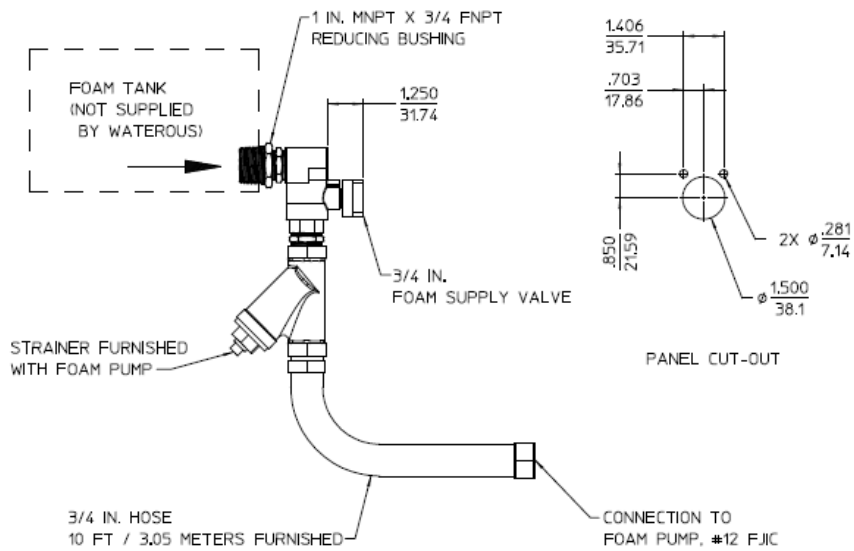

OPTIONAL FOAM SUPPLY HOSE KIT
ORDER PART NO. 83430-1B

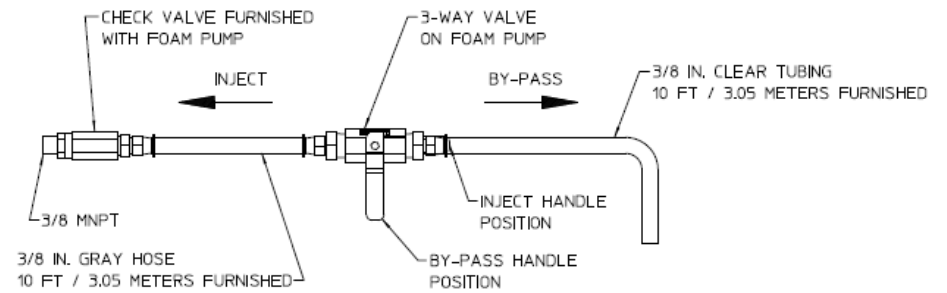

OPTIONAL FOAM INJECTION / BY-PASS HOSE KIT
ORDER PART NO. 83430-2A

ALL DIMENSIONS SHOWN AS INCH/MILLIMETER
($\frac{\text{INCH}}{\text{MILLIMETER}}$)

3/4 MNPT ON 3/4 HOSE
1 MNPT ON 1 HOSE

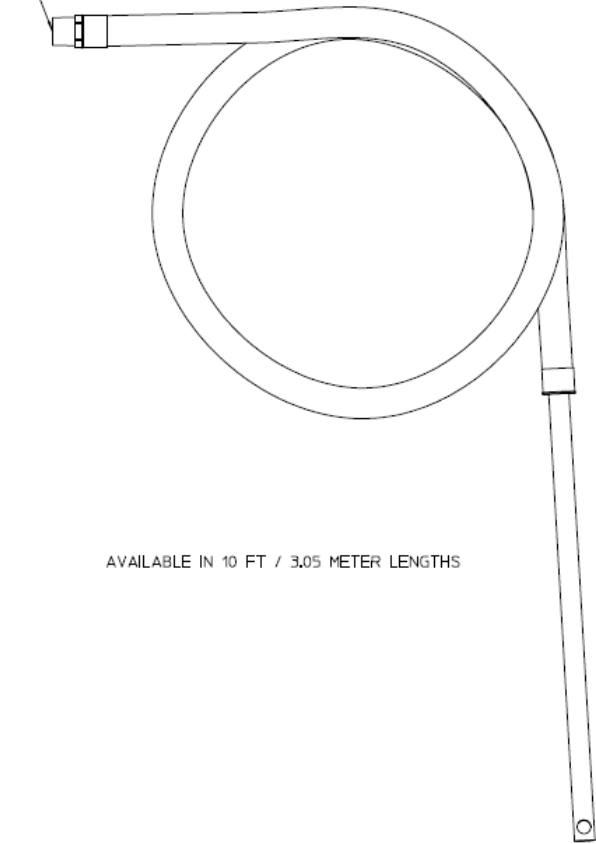

AVAILABLE IN 10 FT / 3.05 METER LENGTHS

OPTIONAL FOAM PICK UP HOSES
ORDER PART NO.:
3/4 IN. HOSE - Q-0308048
1 IN. HOSE - Q-0308059

FOAM PUMP WITH COVER REMOVED

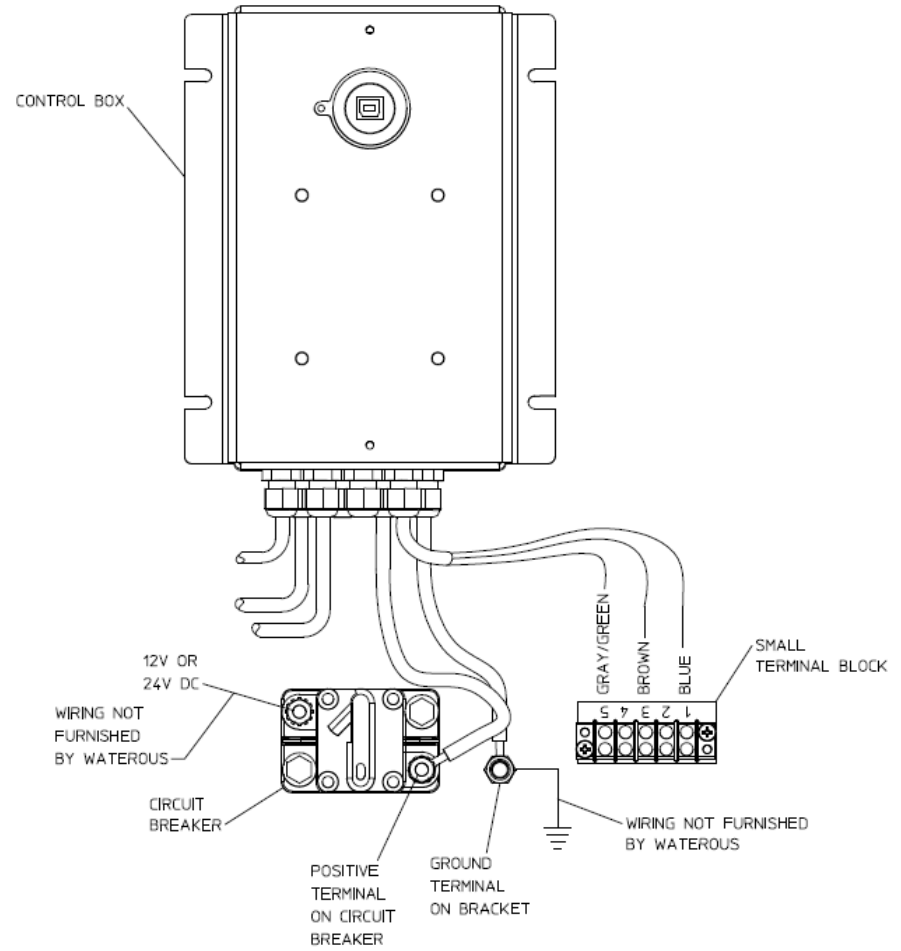

ELECTRICAL CONNECTIONS FOAM PUMP POWER