

**Model 150-ECL Eclipse GEN 2.0 CAF System
As used with CM and CS Series Fire Pumps**

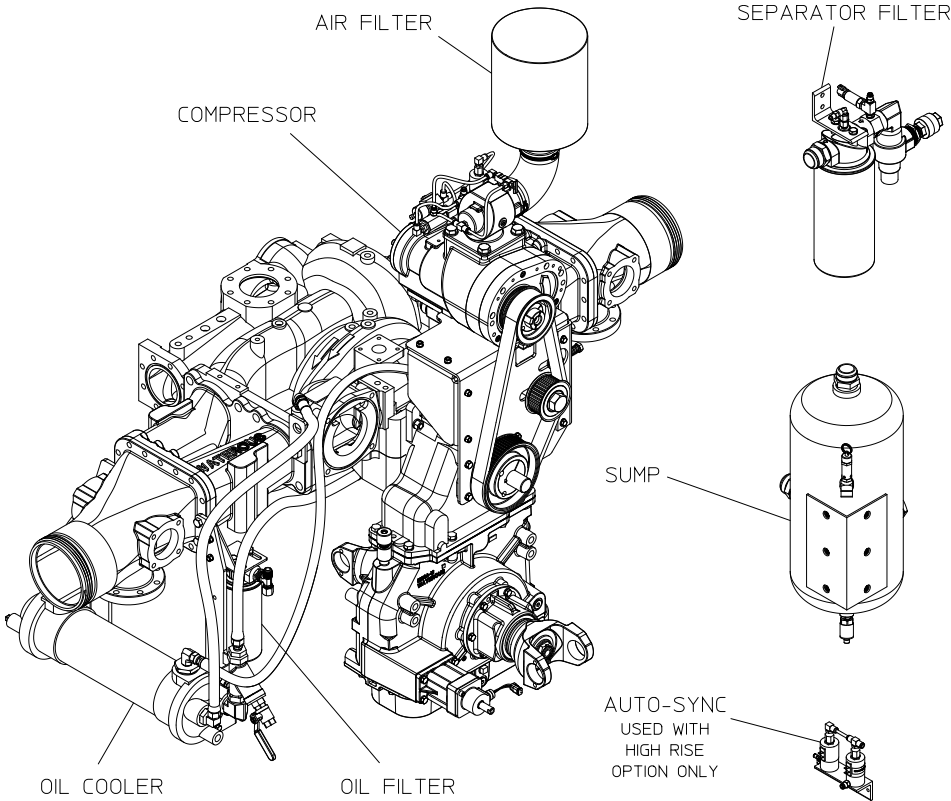

Standard Components: Page

Mounted on Pump:
Compressor, Oil Cooler, Oil Filter2

Shipped Loose:
Sump (Oil Reservoir).....3
Air Filter4
Separator Filter.....5
Auto-Sync (Used with High Rise Option Only)6
Panel Plates6

Foam Pumps:
Models Aquis 3.0 or Aquis 6.0:See F-1031-2447
Foam Generators (CAF Discharge)See DPL83637

Optional Components:
Panel Mounted Oil Cooler Strainer7
Auxiliary Air Connection.....8
Oil Inject Check Valve.....See DPL83810
Hose and Fitting Kit.....See DPL83810

Schematics:

Hydraulic:
With In-Line Oil Cooler Strainer9
With Panel Mounted Oil Cooler Strainer10

Air Circuit:
Without High Rise Option.....11
With High Rise Option12

Electrical (See Foam Generators).....See DPL83637

NOTES:

1. SEE DRAWING DPL82843 FOR CM SERIES FIRE PUMP DIMENSIONS.
2. SEE DRAWING DPL82791 FOR CS SERIES FIRE PUMP DIMENSIONS.

ALL DIMENSIONS SHOWN AS INCH/MILLIMETER
 (INCH)
 (MILLIMETER)

FRONT



REAR

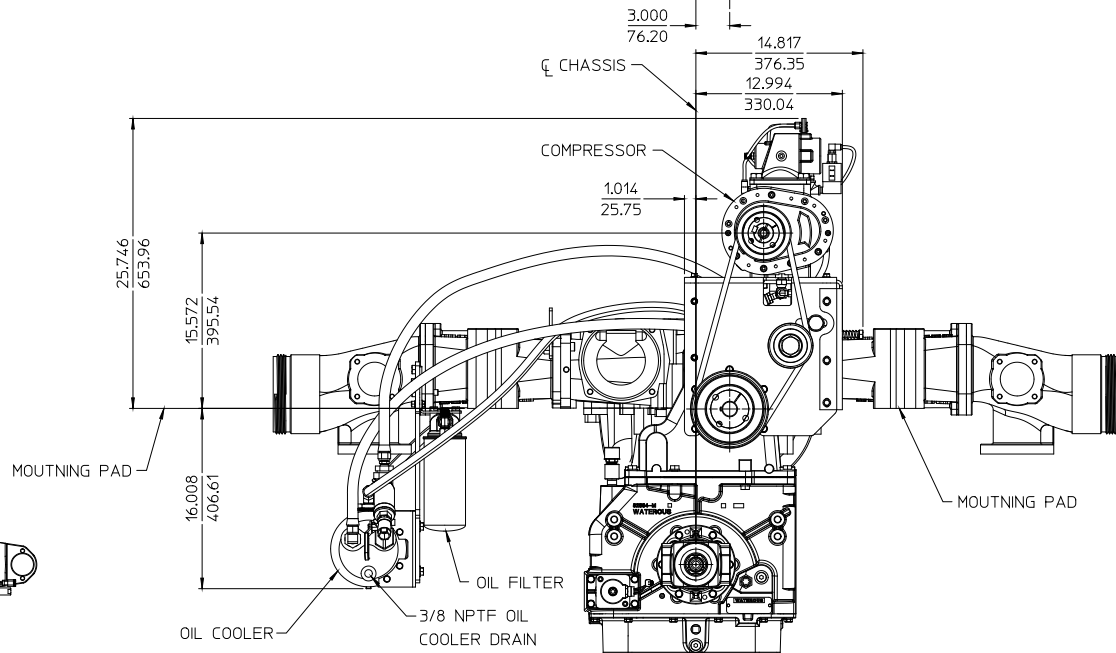
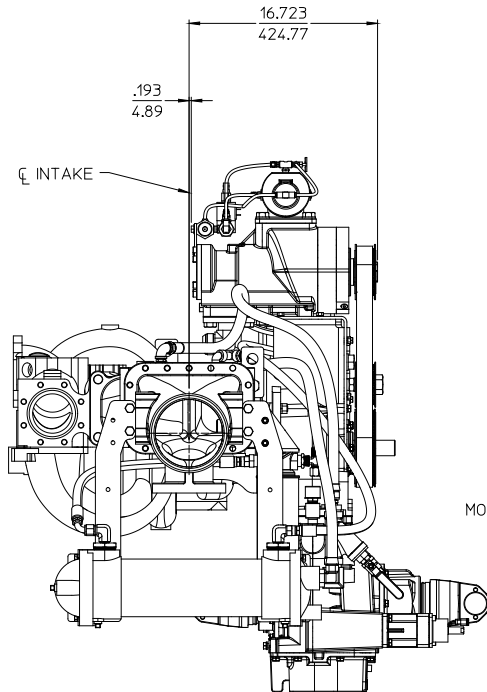
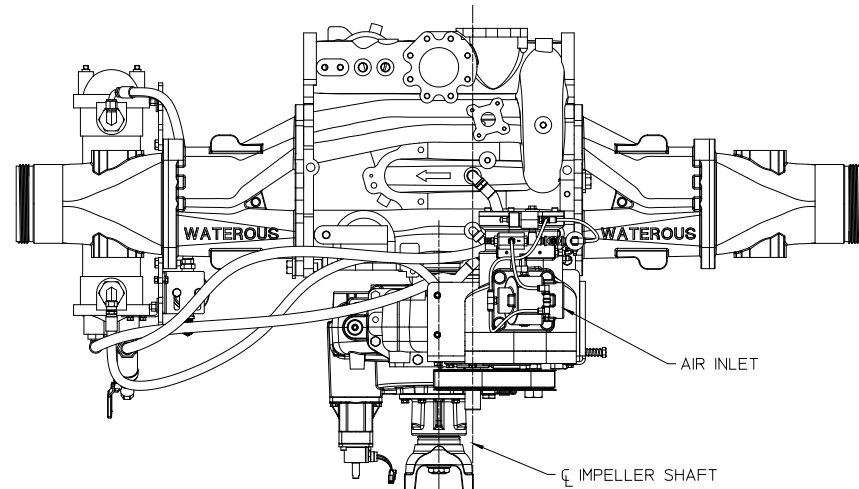

PUMP AND COMPRESSOR

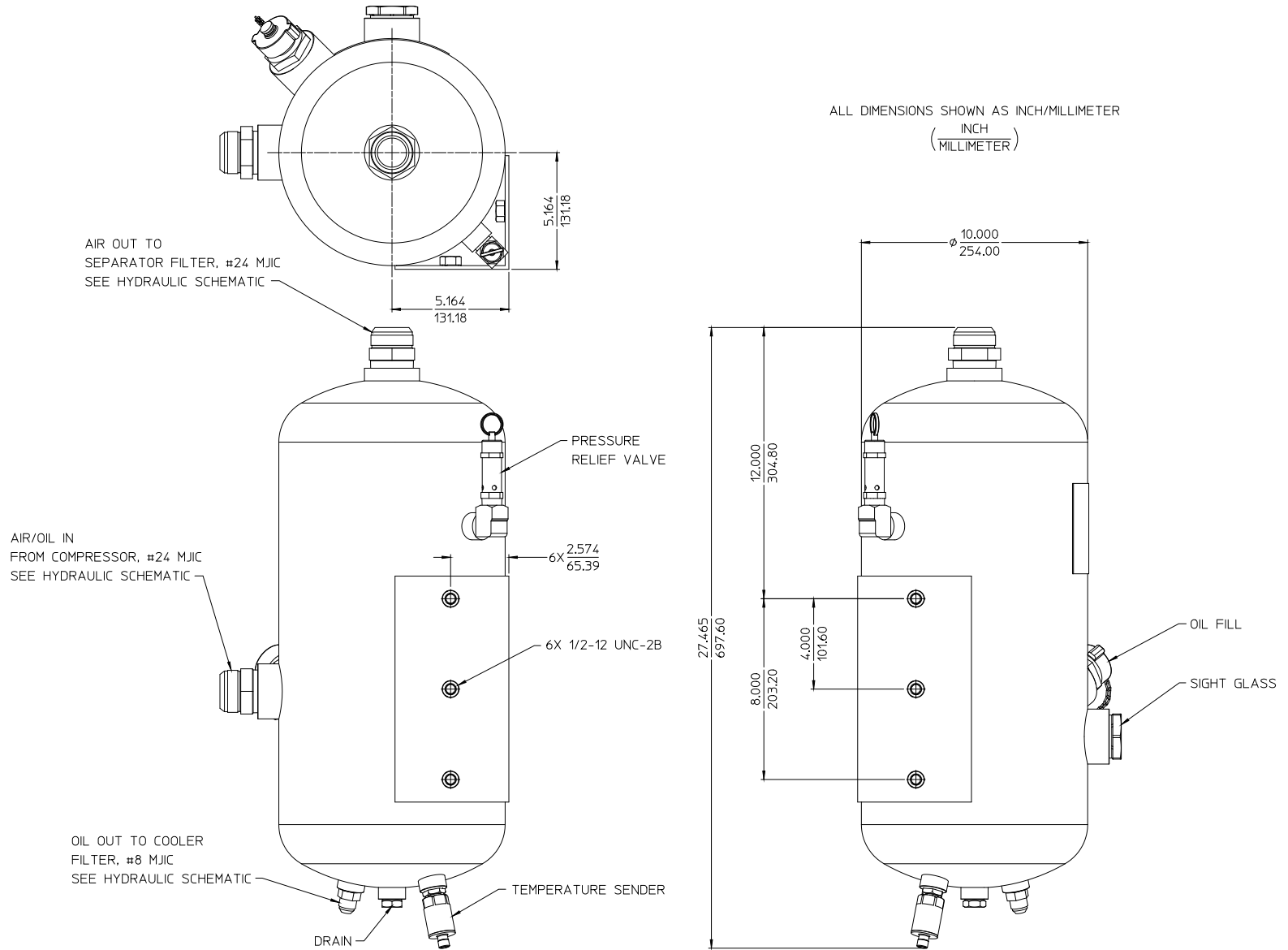

SUMP (OIL RESERVOIR)

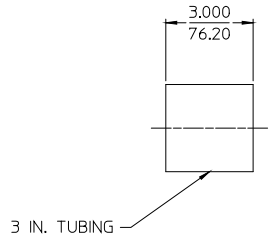
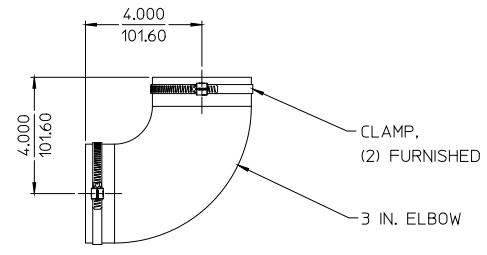
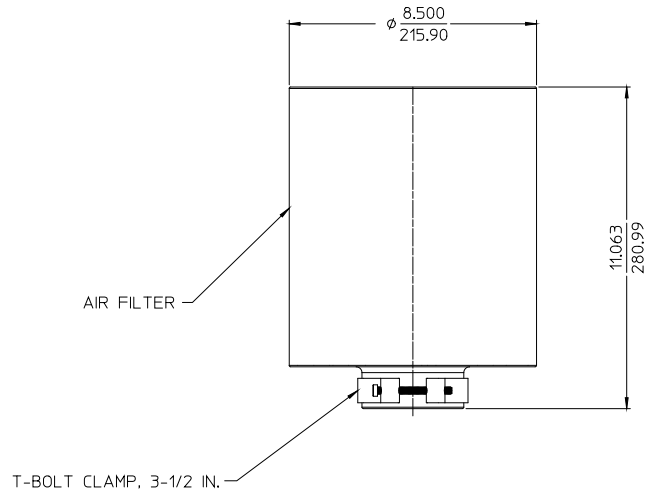

AIR FILTER

ALL DIMENSIONS SHOWN AS INCH/MILLIMETER
 (INCH / MILLIMETER)

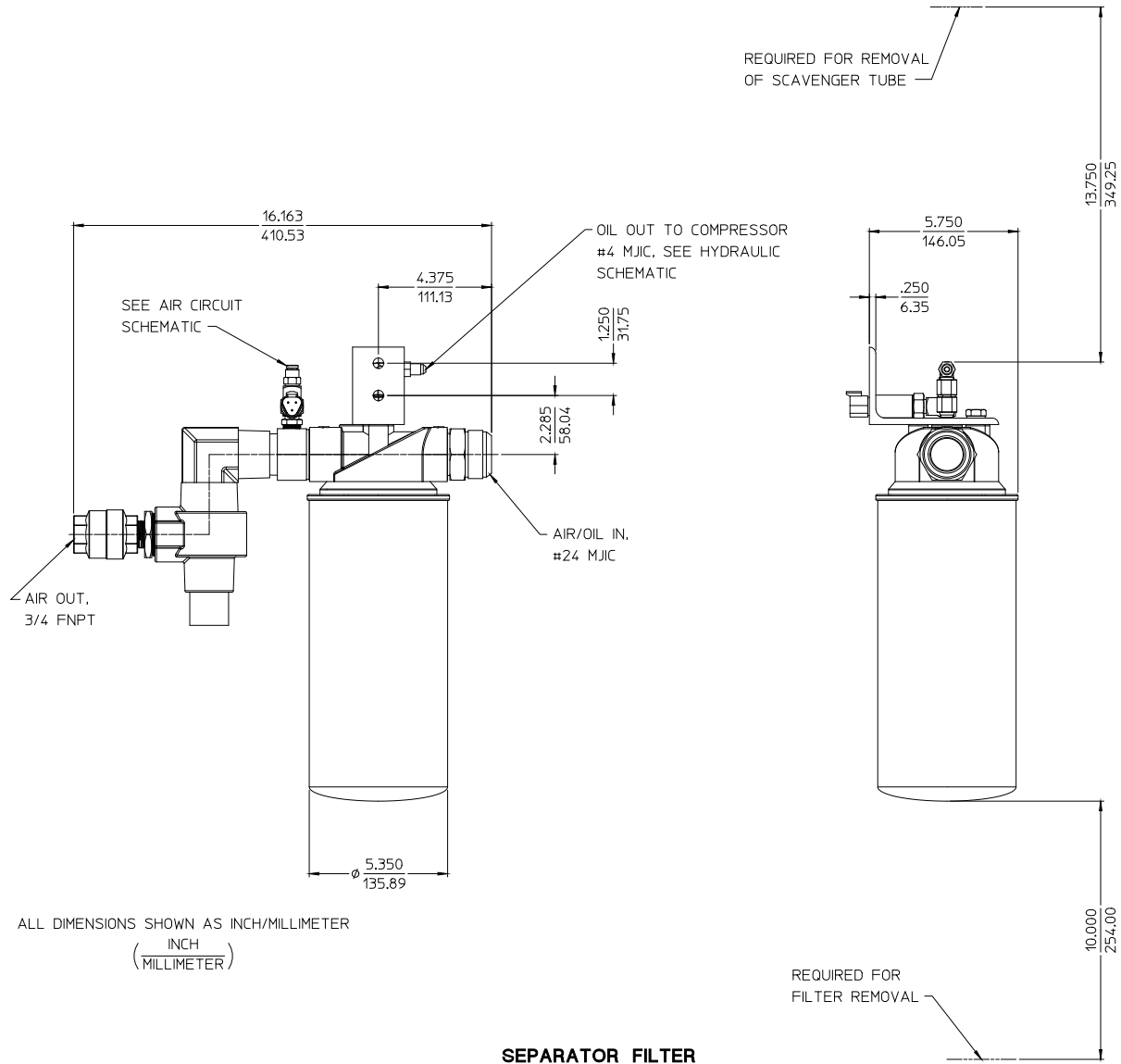

ALL DIMENSIONS SHOWN AS INCH/MILLIMETER
(INCH)
(MILLIMETER)

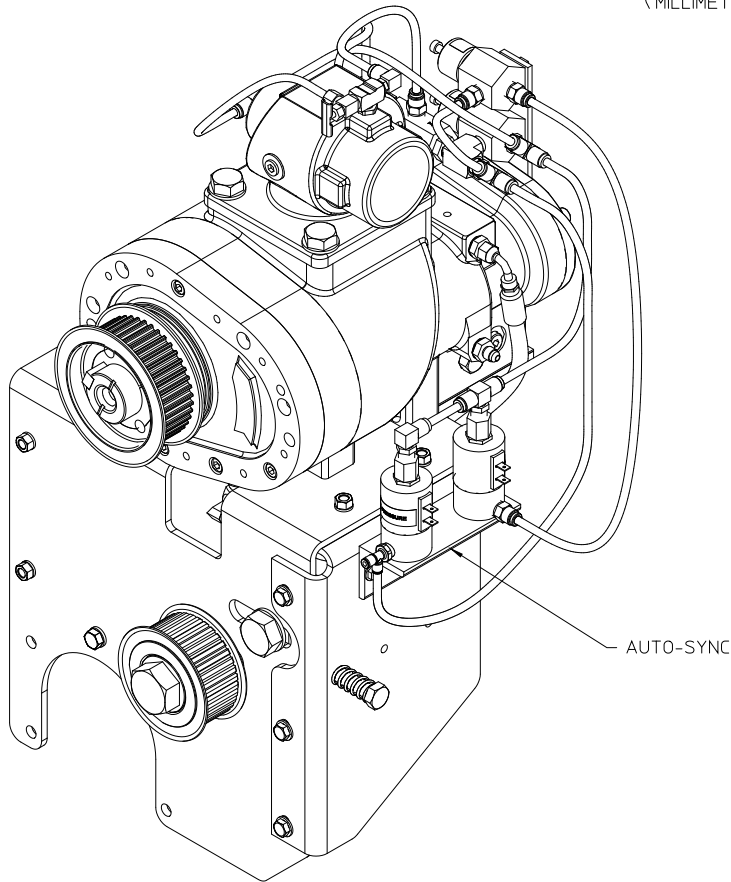

AUTO-SYNC

USED WITH HIGH RISE OPTION ONLY

MOUNTED ON COMPRESSOR AT FACTORY

FOR AIR CONNECTIONS SEE AIR CIRCUIT SCHEMATIC WITH HIGH RISE OPTION.

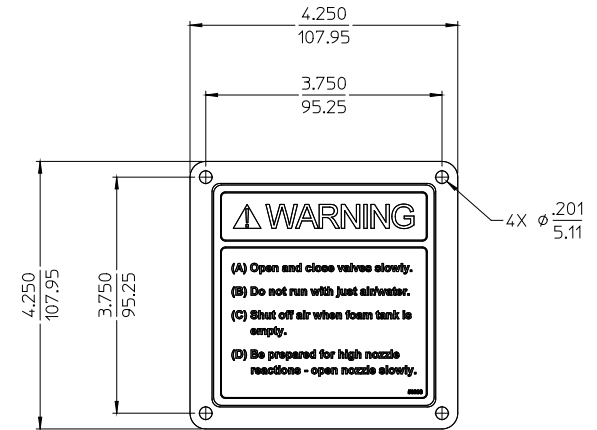

CAFS WARNING

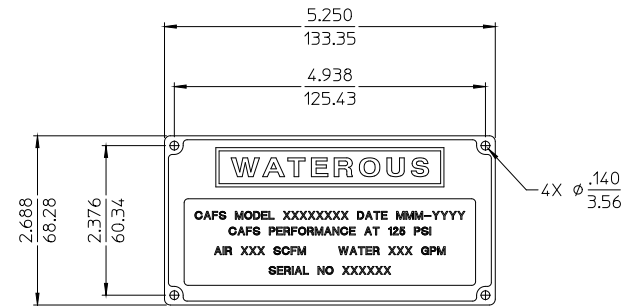

SERIAL PLATE

PANEL PLATES

ALL DIMENSIONS SHOWN AS INCH/MILLIMETER
($\frac{\text{INCH}}{\text{MILLIMETER}}$)

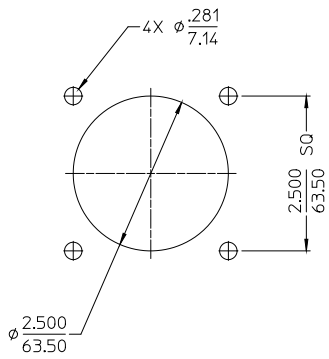

PANEL CUT-OUT

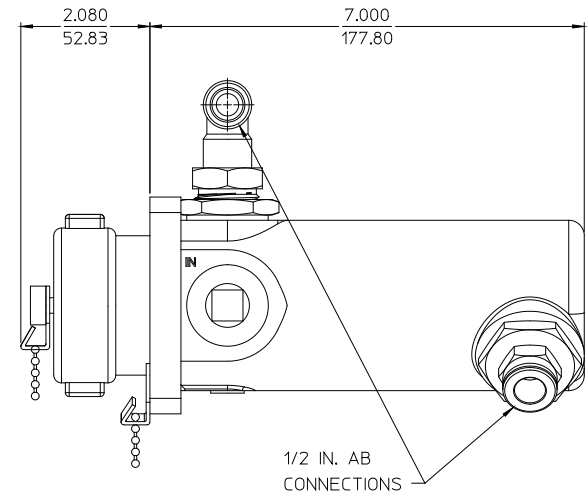
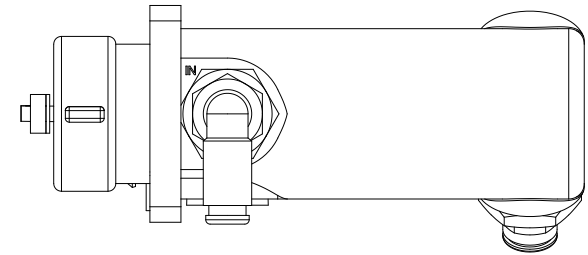
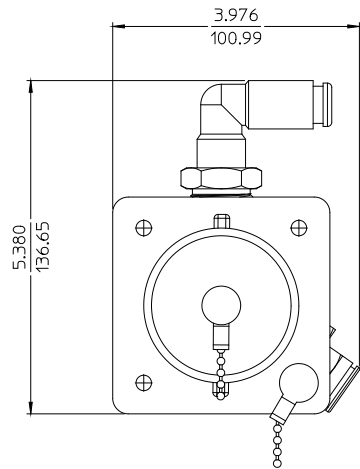

PANEL MOUNTED STRAINER

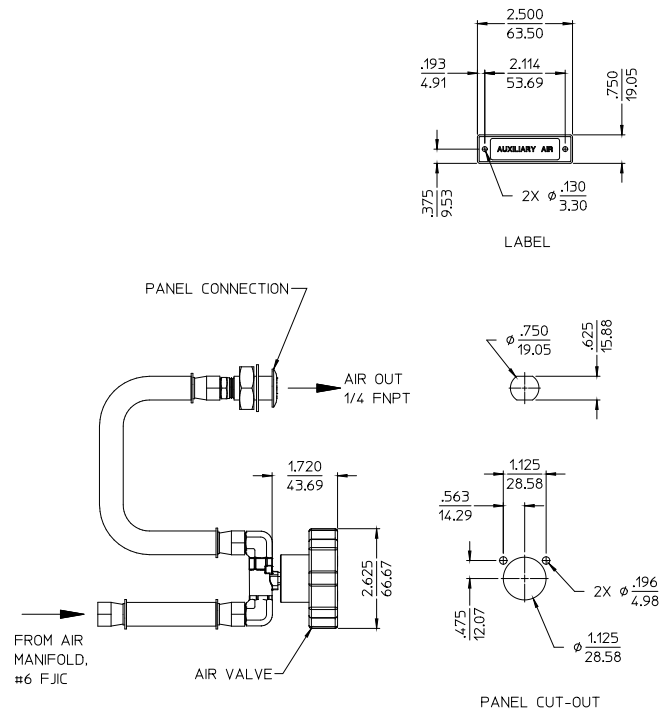

1/4 FNPT CONNECTION
(HOSES AND FITTINGS FURNISHED)
ORDER PART NO. 83360-3A

ALL DIMENSIONS SHOWN AS INCH/MILLIMETER
(INCH / MILLIMETER)

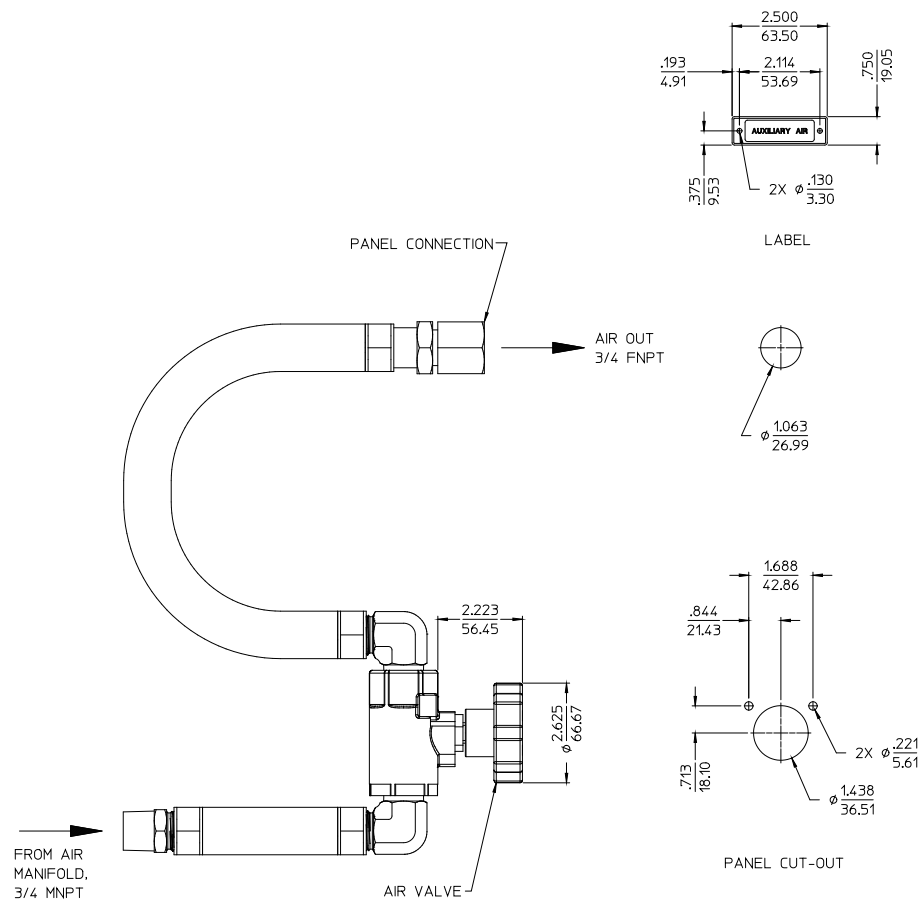

3/4 NPT CONNECTION
(HOSES AND FITTINGS FURNISHED)
ORDER PART NO. 83360-3B

OPTIONAL AUXILIARY CONNECTION

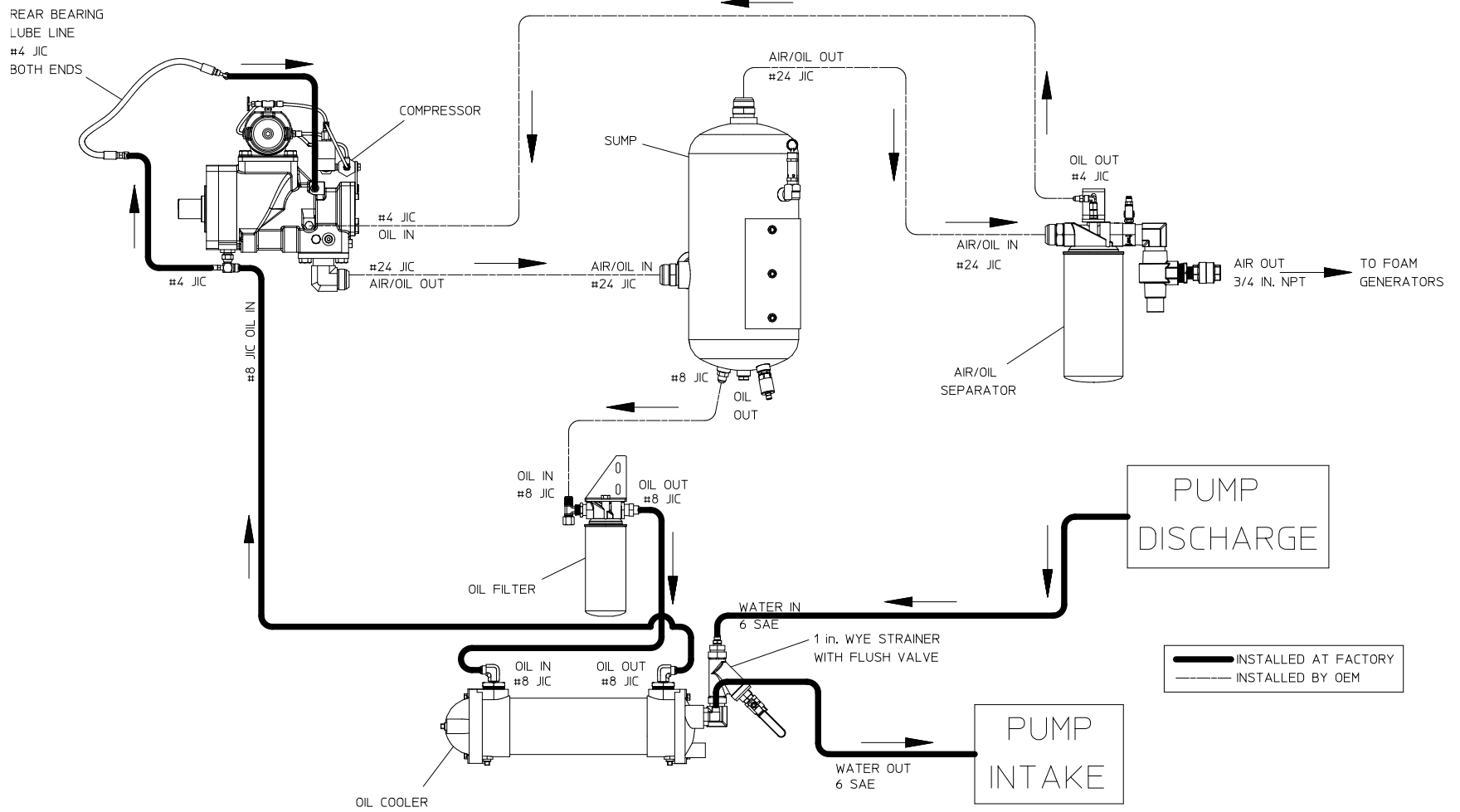

SCHEMATIC - HYDRAULIC
WITH IN-LINE OIL COOLER STRAINER

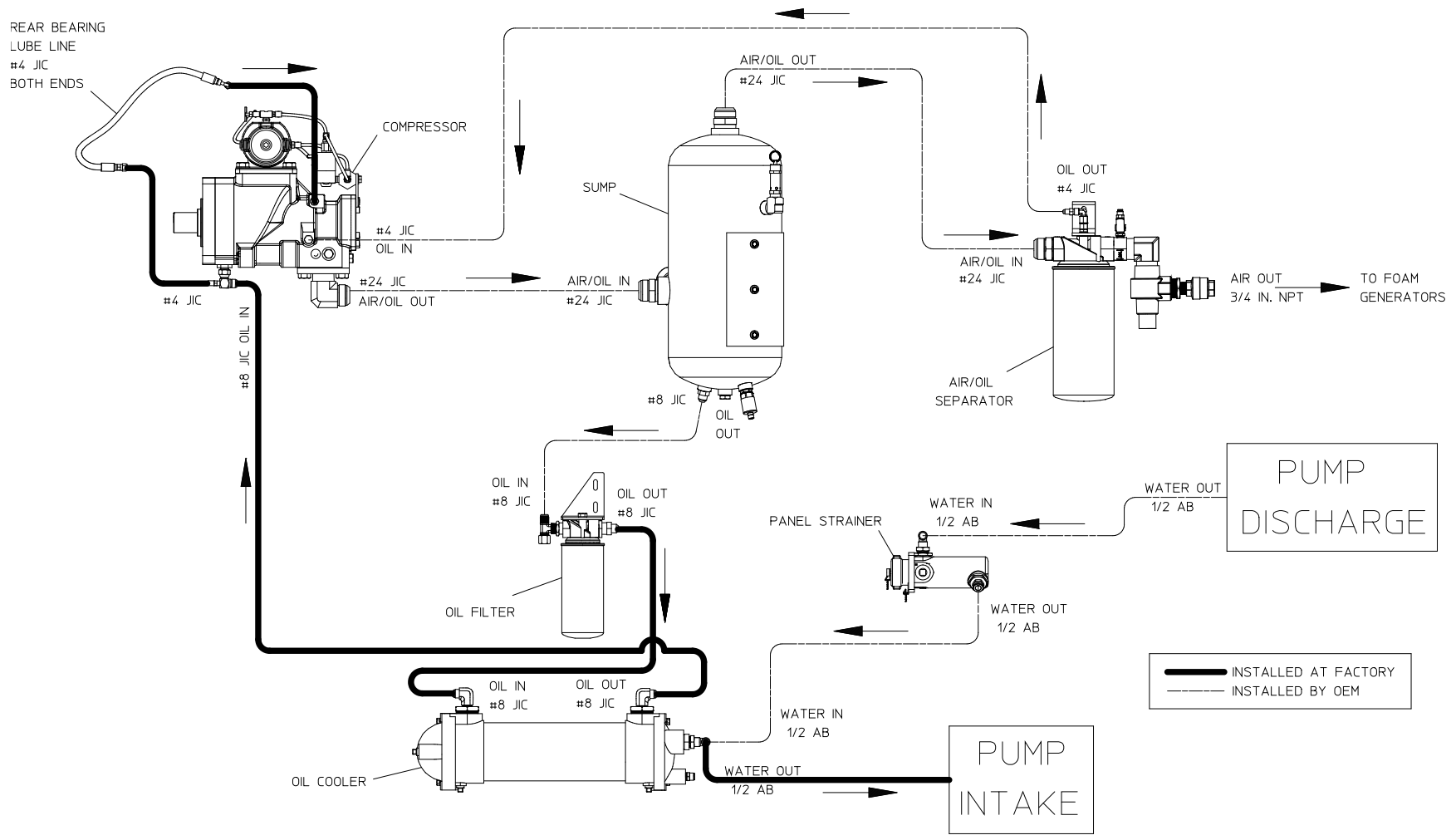

SCHEMATIC – HYDRAULIC
 WITH PANEL MOUNTED OIL COOLER STRAINER

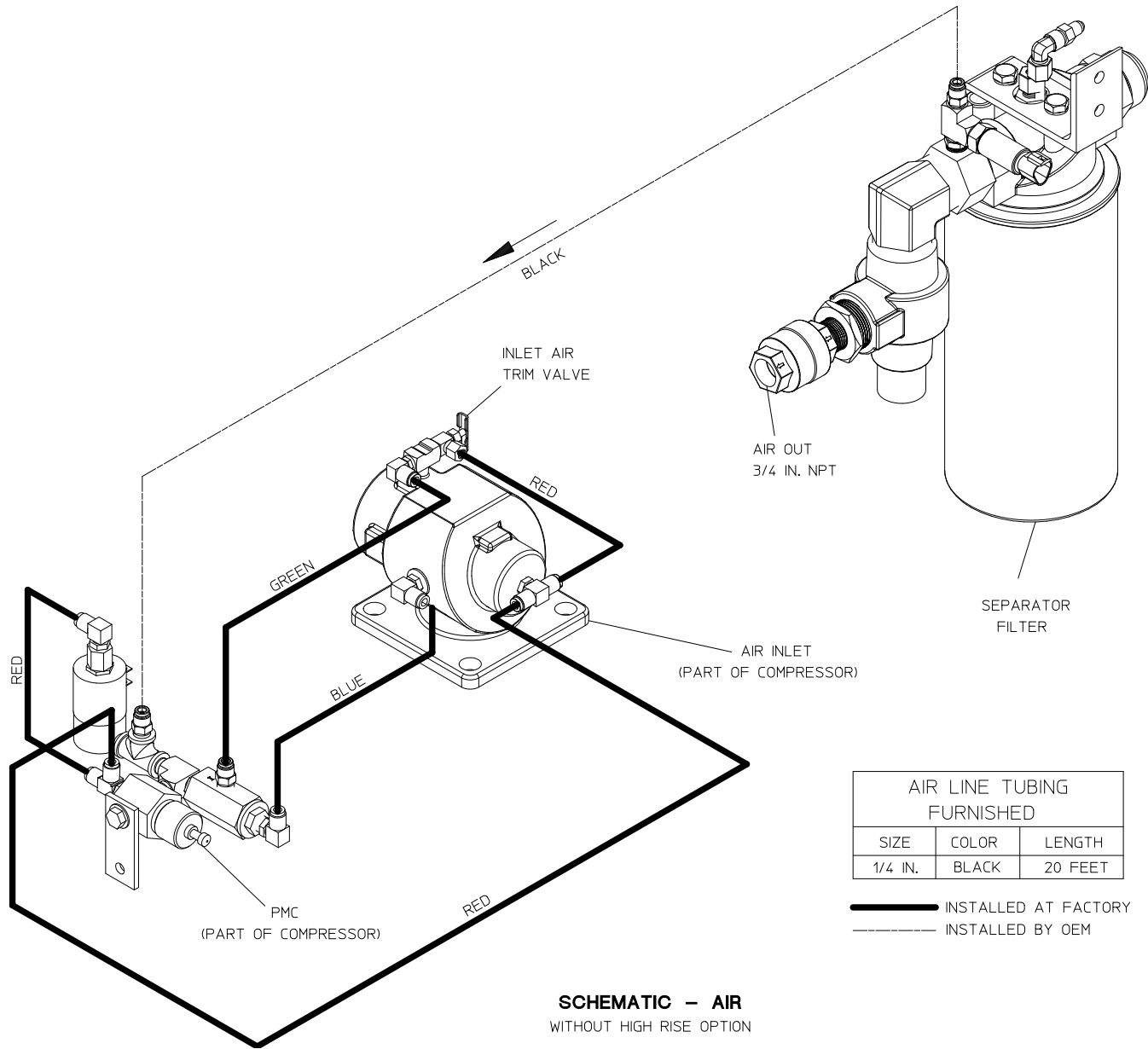

SCHEMATIC - AIR
 WITHOUT HIGH RISE OPTION

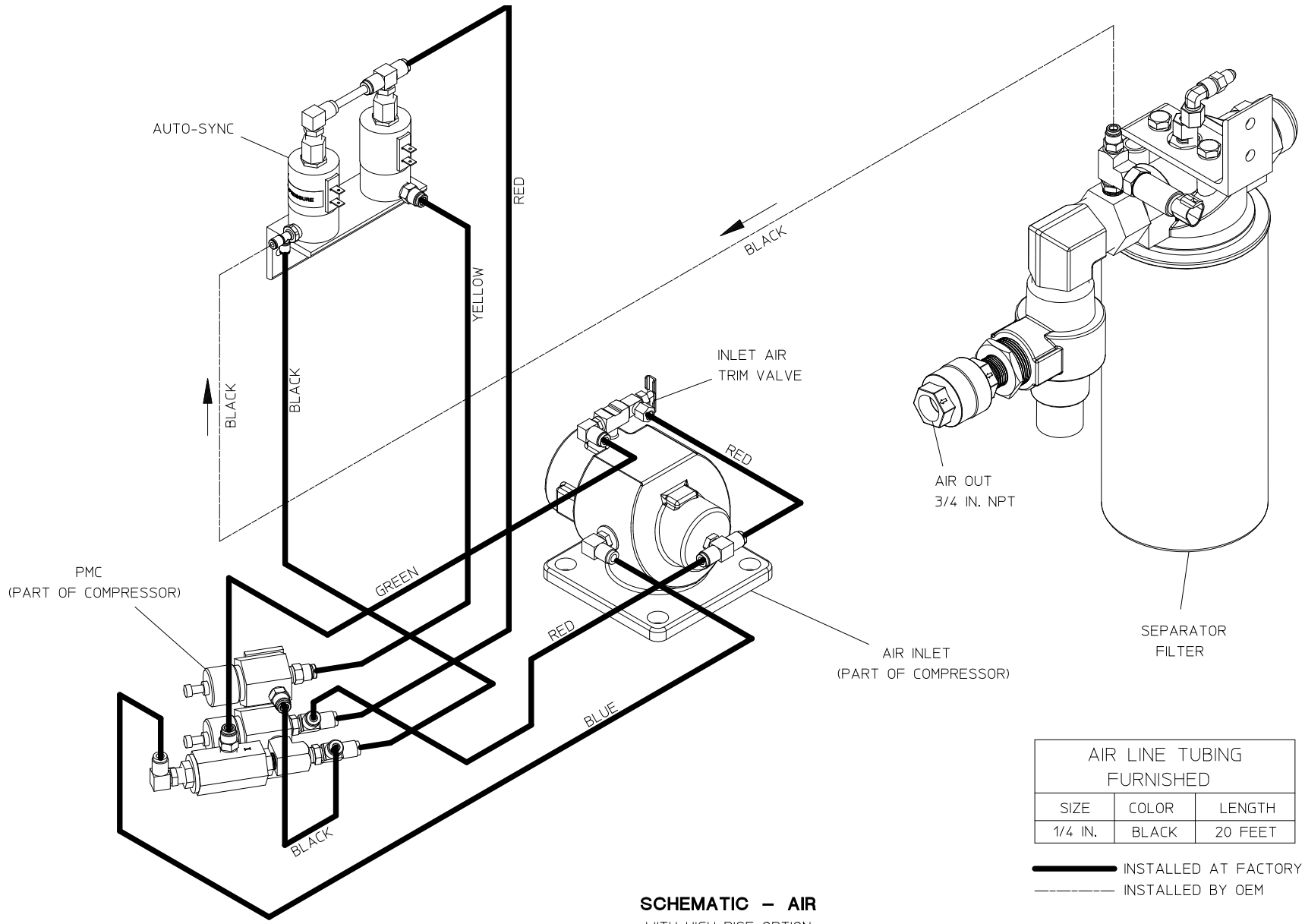

SCHEMATIC - AIR
 WITH HIGH RISE OPTION