

Eclipse CAF System As used with CM and CS Series Fire Pumps

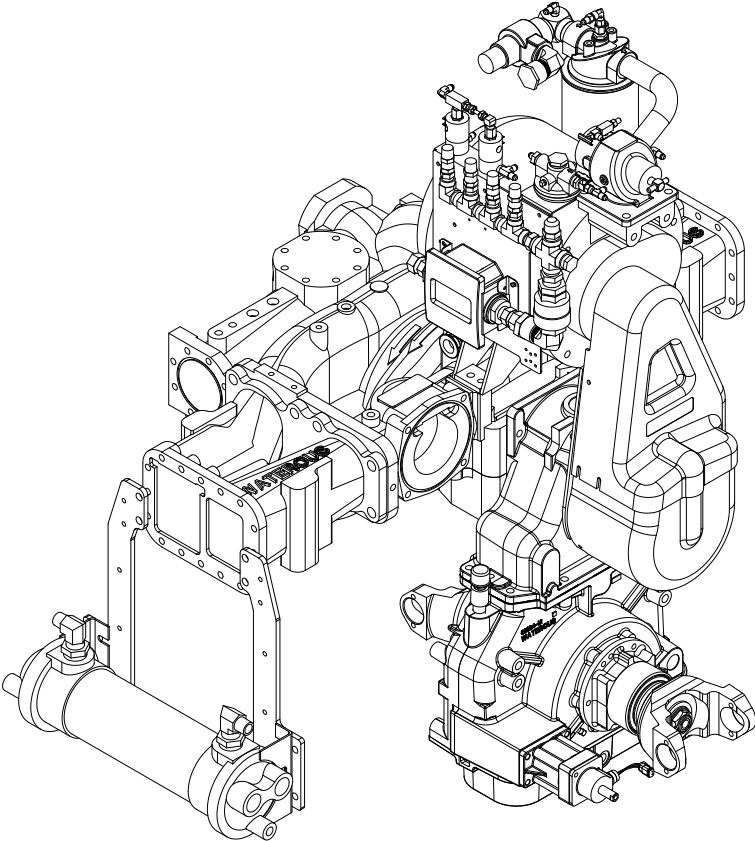

Available with the Following Pumps:

CMU, CS and CSU Series, Not available with CMU Series

Standard Components:

Mounted on Pump:

- Compressor, Separator Filter, Auto-Sync,
Balance Valve, Oil Cooler, Oil Filter2

Shipped Loose:

- Auto-Sync Panel Plates3
- Air Flow Meter Panel3
- Air Filter4
- Oil Temperature Gauge4

CAF Discharge:

- Air Discharge Check Valve KitsSee DPL83477
- ICS ValvesSee DPL83478
- Static MixersSee DPL83603
- ManifoldsSee DPL83682

Foam Pumps:

Aquis 1.5, Aquis 3.0 or Aquis 6.0See F-1031-2447

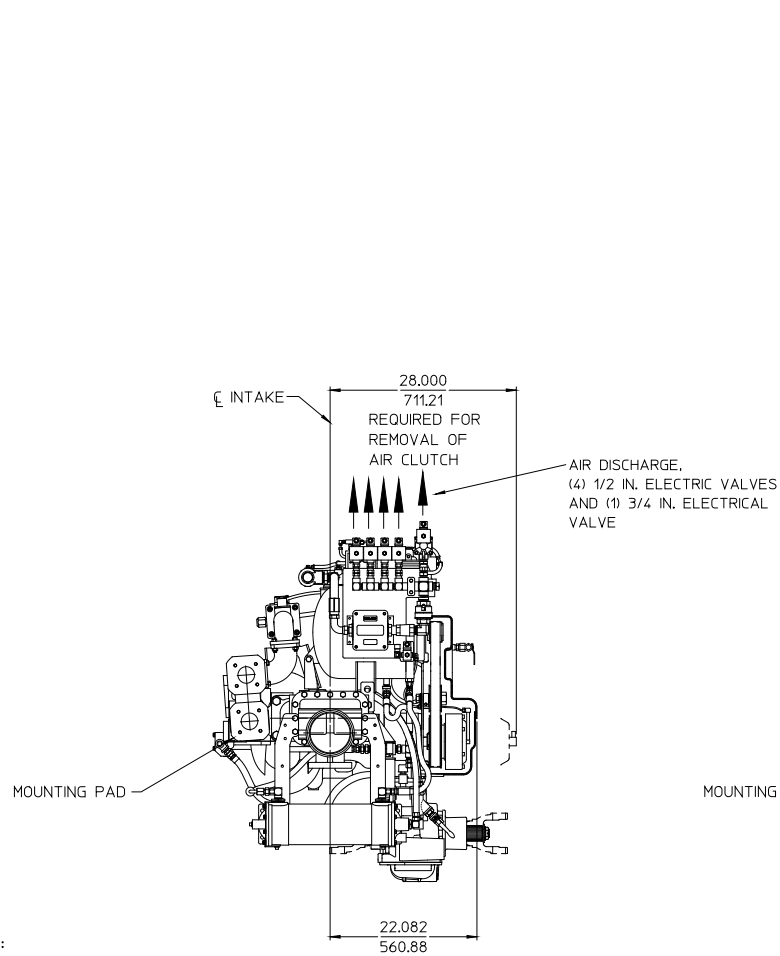

- NOTES:
- SEE DRAWING DPL82843 FOR CM SERIES FIRE PUMP DIMENSIONAL.
 - SEE DRAWING DPL82791 FOR CS SERIES FIRE PUMP DIMENSIONAL.
 - LEFT SIDE PUMP MOUNTED RELIEF VALVE NOT AVAILABLE.

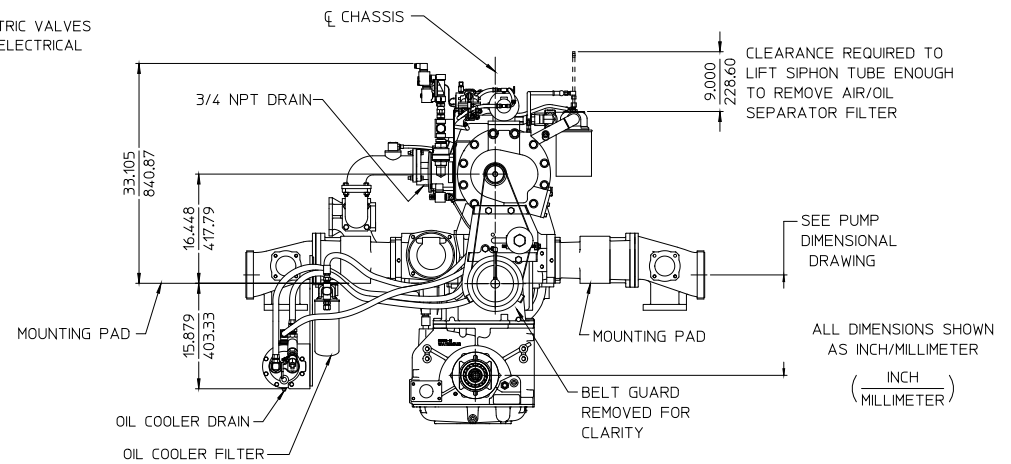
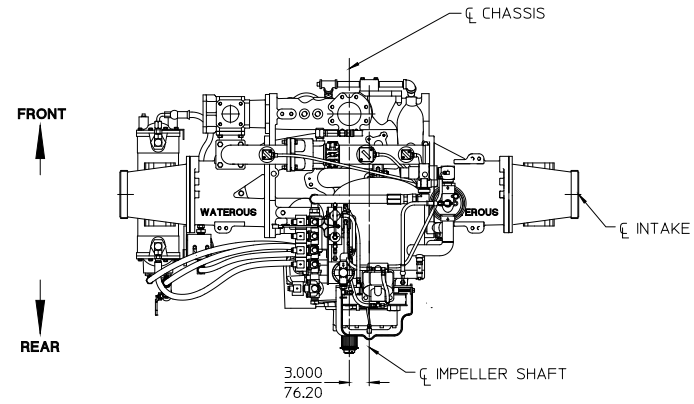

COMPONENTS MOUNTED ON PUMP

SEE PUMP DIMENSIONAL DRAWING

ALL DIMENSIONS SHOWN AS INCH/MILLIMETER

(INCH / MILLIMETER)

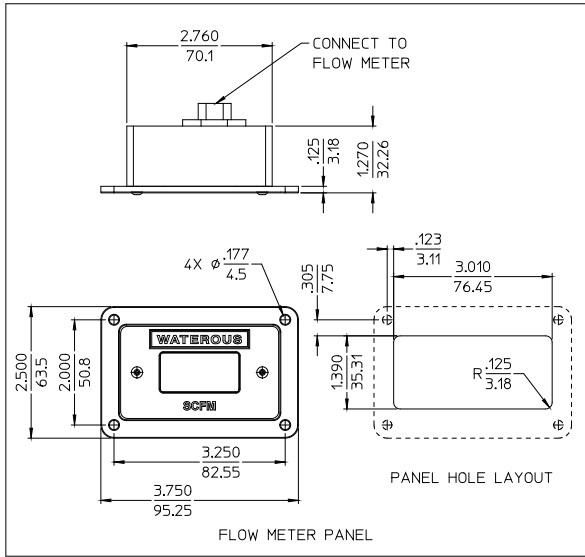
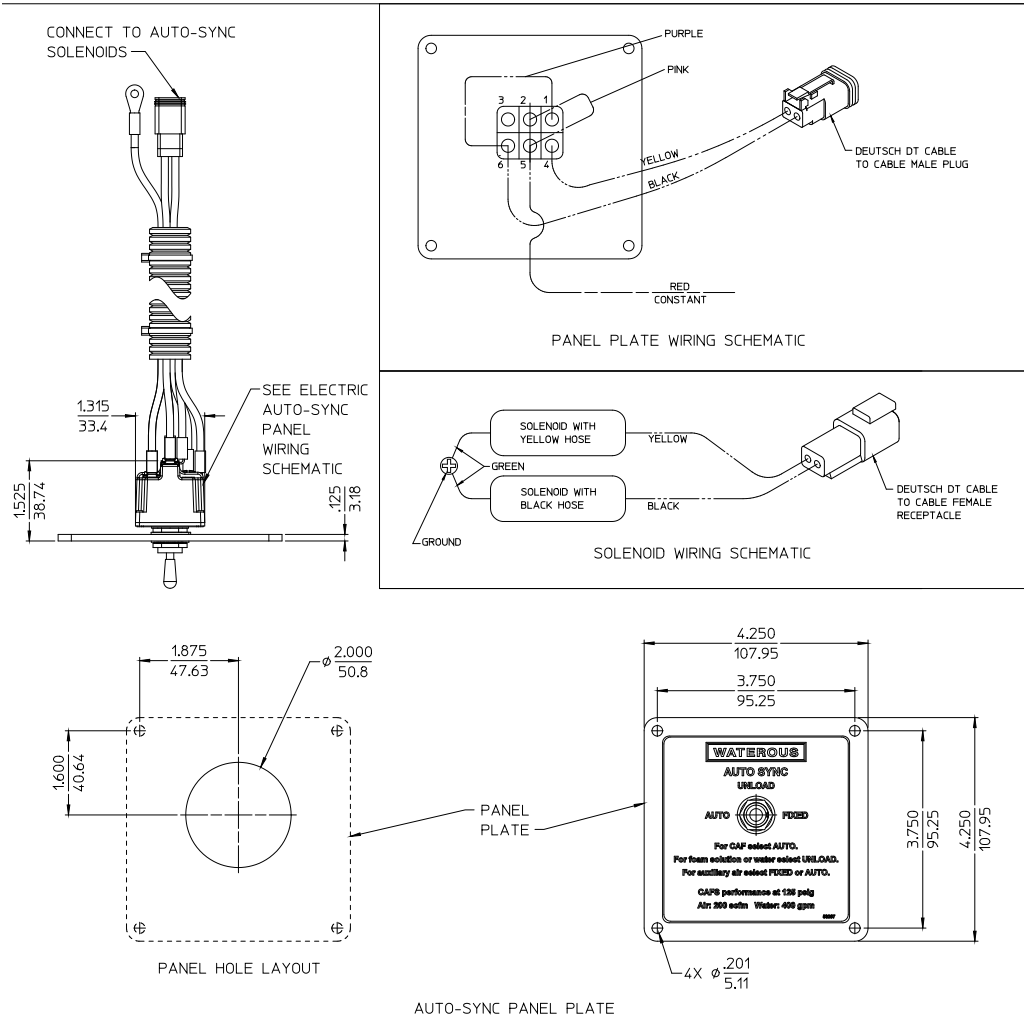

ALL DIMENSIONS SHOWN AS INCH/MILLIMETER

(INCH)
(MILLIMETER)

COMPONENTS SHIPPED LOOSE

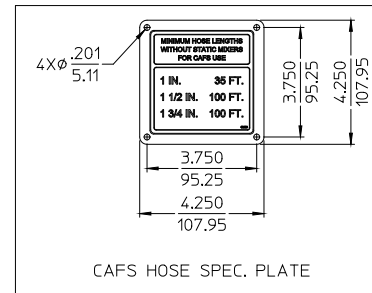
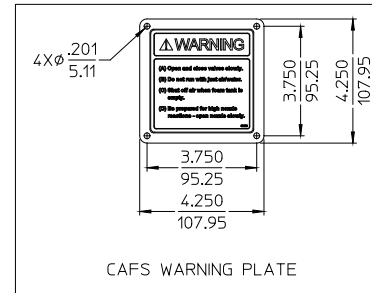
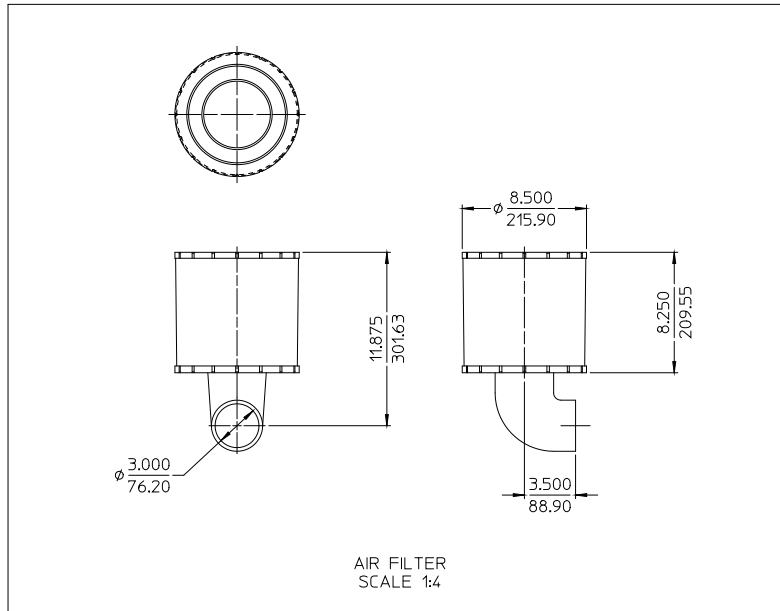
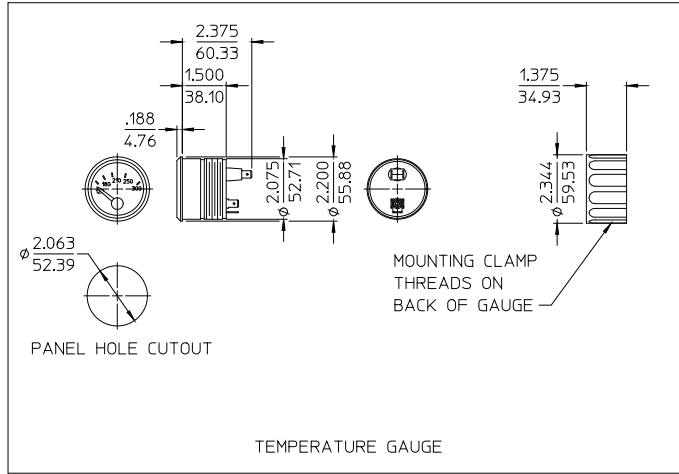

ALL DIMENSIONS SHOWN
AS INCH/MILLIMETER
(INCH)
(MILLIMETER)

COMPONENTS SHIPPED LOOSE