

Model 150-ESECL Eclipse GEN 2.0 CAF System As used with TC20 Series PTO's

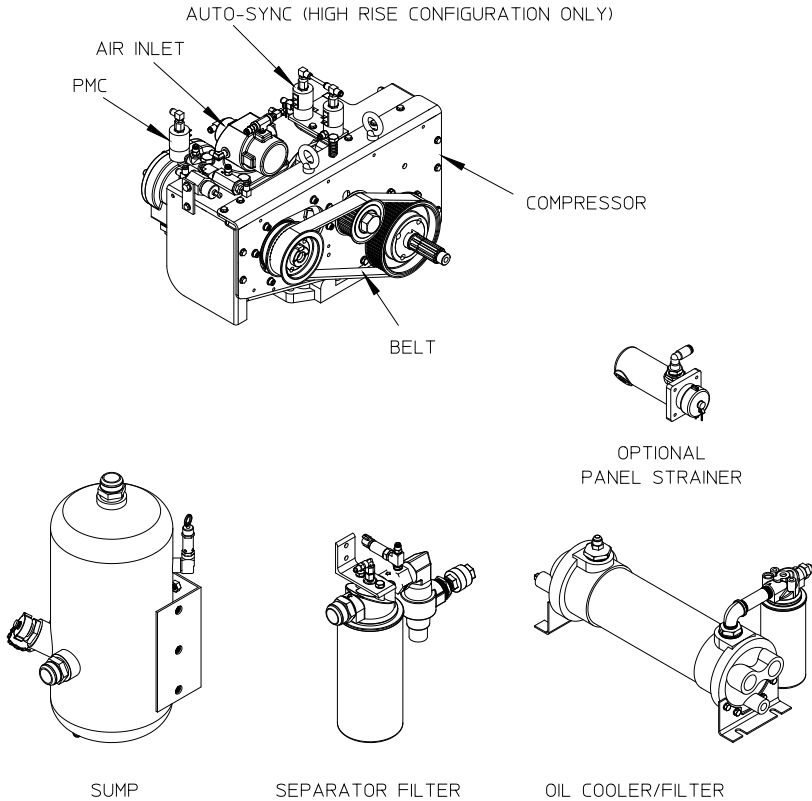

Standard Components:	Page
Mounted:	
PTO and Compressor:	
Input and Output Shaft Driveline	2
Input Shaft Only Driveline	3
Available Ratios and Drop Dimensions.....	4
Mounting Bracket Attachment Locations.....	5
Shipped Loose:	
Air Filter	6
Panel Plates.....	6
Sump (Oil Reservoir)	7
Separator Filter	8
Oil Cooler	9
Foam Pumps:	
Models Aquis 3.0 or Aquis 6.0:	See F-1031-2447
Foam Generators (CAF Discharge)	See DPL83637
Optional Components:	
Panel Mounted Oil Cooler Water Strainer.....	9
Auxiliary Air Connection	10
Oil Inject Check Valve	See DPL83810
Hose and Fitting Kit.....	See DPL83810
Schematics:	
Hydraulic:	
In-Line Oil Cooler Strainer	11
Panel Mounted Oil Cooler Strainer	12
Air Circuit:	
Without High Rise Option	13
With High Rise Option.....	14
Electrical (See Foam Generators)	See DPL83637

TABLE 1 - AVAILABLE DRIVELINES / MODELS							
DRIVELINE			OPTIONAL END YOKE AND COMPANION FLANGES AVAILABLE FROM WATEROUS. SEE DETAIL D ON PAGE 5				PTO MODELS
TYPE	SIZE	SPLINE	YOKE		CROSS AND BEARING KIT	COMPANION FLANGE	
			SPICER SERIES	PART NUMBER		SPICER SERIES	PART NUMBER
EXTRA HEAVY DUTY	2.35 INCH	2.35-46T INVOLUTE	1710	V 2837	V 2839	1480/1610	V 3719
			1810	V 2838	V 2840		
			SPL140	V 3388	V 3389	1710/1810	V 3619

NOTES:

- SEE TABLE 2 ON PAGE 4 FOR AVAILABLE RATIOS.
- MAXIMUM DRIVE SHAFT LENGTH: 45 INCHES
MAXIMUM U-JOINT ANGLE: 3°
- SEE DRAWING DPL83000 FOR ADDITIONAL DETAILS OF TC20 SERIES PTO.
- SEE DPL82086 FOR SHIFT DETAILS.

ALL DIMENSIONS SHOWN AS INCH/MILLIMETER
(INCH / MILLIMETER)

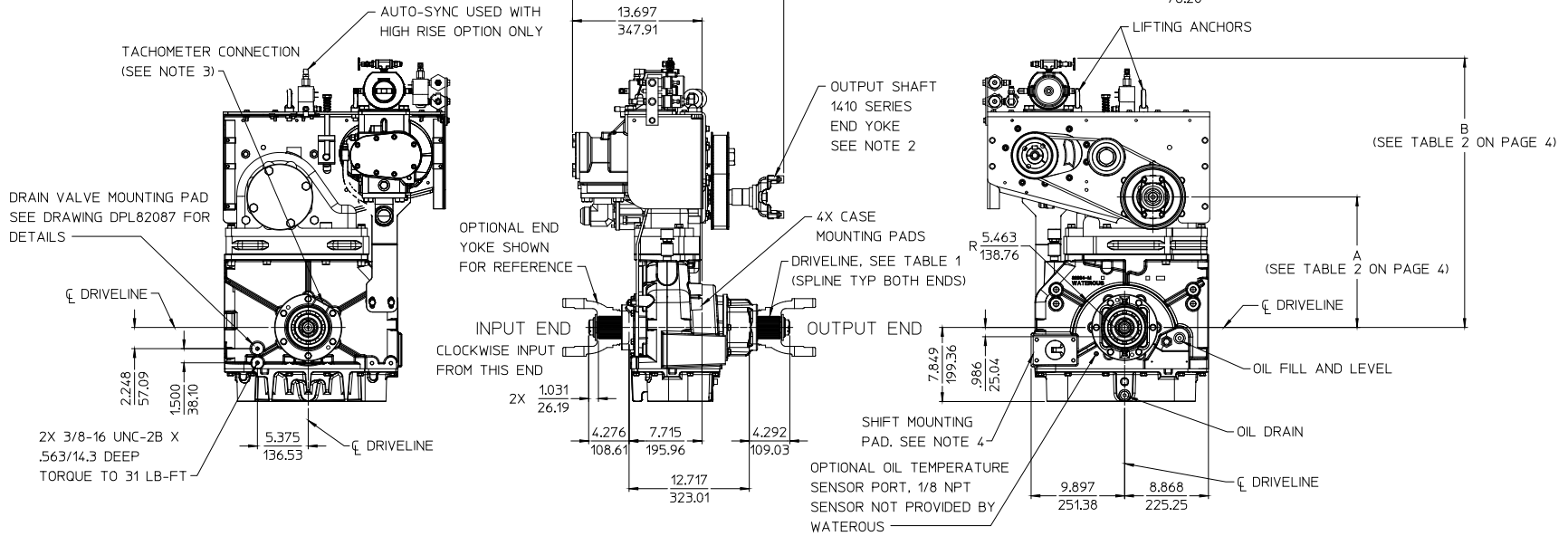

INPUT AND OUTPUT SHAFT DRIVELINE

TABLE 1 - AVAILABLE DRIVELINES / MODELS								
DRIVELINE			OPTIONAL END YOKES AND COMPANION FLANGES AVAILABLE FROM WATEROUS. SEE DETAIL D ON PAGE 5				PTO MODELS	
TYPE	SIZE	SPLINE	YOKE		CROSS AND BEARING KIT	COMPANION FLANGE		
			SPLICER SERIES	PART NUMBER		SPLICER SERIES		PART NUMBER
EXTRA HEAVY DUTY	2.35 INCH	2.35-46T INVOLUTE	1710	V 2837	V 2839	1480/1610	V 3719	
			1810	V 2838	V 2840			
			SPL140	V 3388	V 3389	1710/1810	V 3619	TC20B, TC20C, TC20D, TC20E, TC20F

NOTES:

- SEE TABLE 2 ON PAGE 4 FOR AVAILABLE RATIOS.
- MAXIMUM DRIVE SHAFT LENGTH: 45 INCHES
MAXIMUM U-JOINT ANGLE: 3°
- SEE DRAWING DPL83000 FOR ADDITIONAL DETAILS OF TC20 SERIES PTO.

ALL DIMENSIONS SHOWN AS INCH/MILLIMETER
(INCH
MILLIMETER)

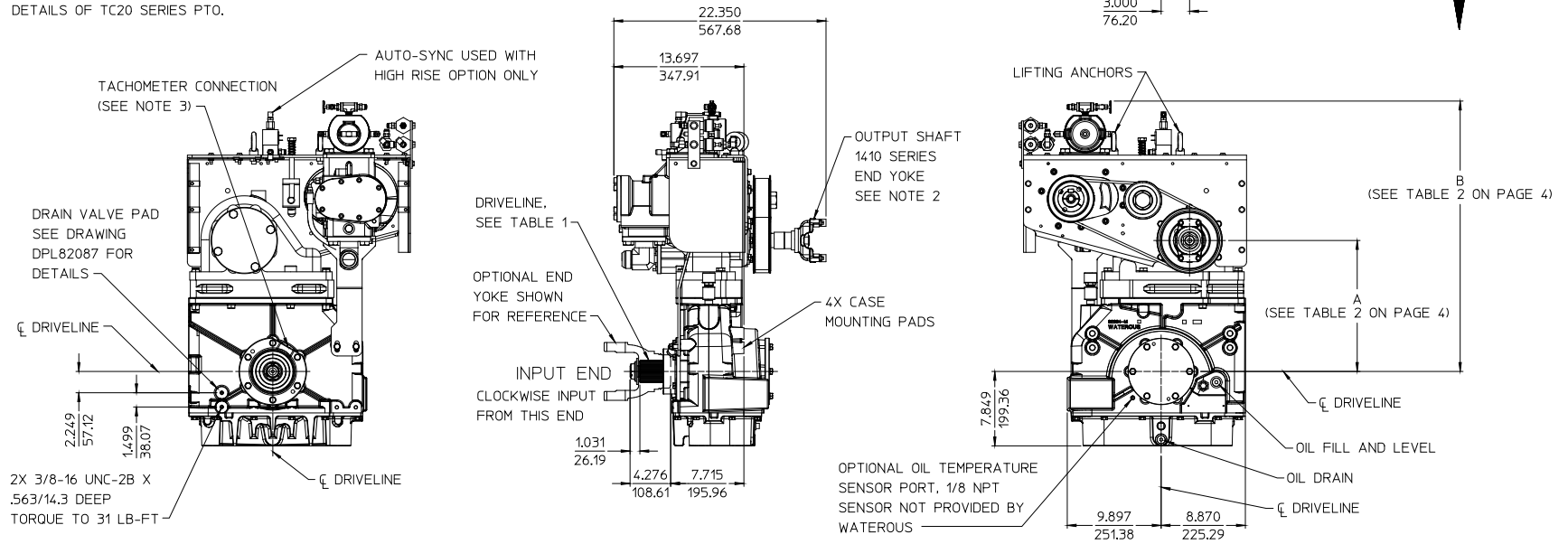

INPUT SHAFT ONLY DRIVELINE

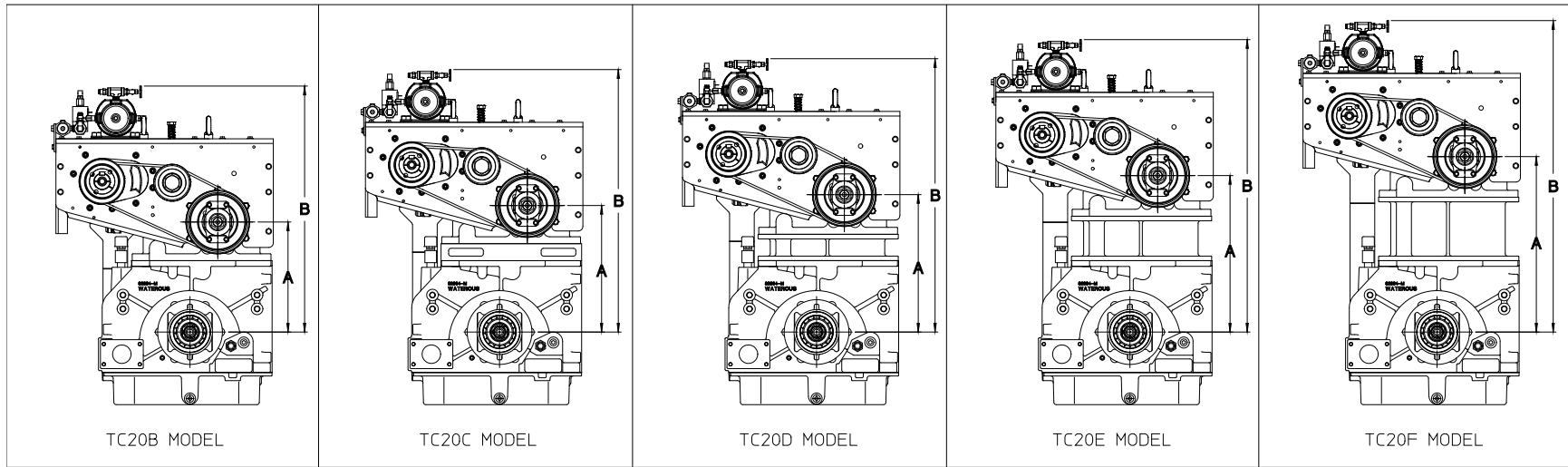

TABLE 2 - AVAILABLE RATIOS

DRIVE TO DRIVEN RATIO	TC20B		TC20C		TC20D		TC20E		TC20F	
	DIMENSION A	DIMENSION B	DIMENSION A	DIMENSION B	DIMENSION A	DIMENSION B	DIMENSION A	DIMENSION B	DIMENSION A	DIMENSION B
1.14	11.875/301.63	25.576/649.63	13.929/353.80	28.630/727.20	14.959/379.96	29.660/753.36	16.995/431.67	31.696/805.08	19.027/483.29	33.728/856.69
1.27	12.250/311.15	26.951/684.56	14.312/363.52	29.013/736.93	14.825/376.56	29.526/749.96	16.861/428.27	31.562/801.67	18.892/479.86	33.593/853.26
1.41	11.840/300.74	26.541/674.14	13.899/353.03	28.600/726.44	14.931/379.25	29.632/752.65	16.971/431.06	31.672/804.47	19.002/482.65	33.703/856.06
1.48	12.326/313.08	27.027/686.49	13.878/352.50	28.579/725.91	14.907/378.64	29.608/752.04	16.951/430.56	31.652/803.96	18.981/482.12	33.682/855.52
1.58	12.205/310.01	26.906/683.41	13.756/349.40	28.457/722.81	14.788/375.62	29.489/749.02	16.830/427.48	31.531/800.89	18.861/479.07	33.562/852.47
1.69	12.290/312.17	26.991/685.57	13.839/351.51	28.540/724.92	14.876/377.85	29.577/751.26	16.923/429.84	31.624/803.25	18.961/481.61	33.662/855.01
1.79	11.958/303.73	26.659/677.14	14.045/356.74	28.746/730.15	15.072/382.83	29.773/756.23	17.127/435.03	31.828/808.43	19.168/486.87	33.869/860.27
1.88	12.129/308.08	26.830/681.48	13.690/347.73	28.391/721.13	14.717/373.81	29.418/747.22	16.773/426.03	31.474/799.44	18.809/477.75	33.510/851.15
1.97	12.306/312.57	27.007/685.98	13.870/352.30	28.571/725.70	14.912/378.76	29.613/752.17	16.970/431.04	31.671/804.44	19.012/482.90	33.713/856.31
2.03	11.896/302.16	26.597/675.56	13.984/355.19	28.685/728.60	15.028/381.71	29.729/755.12	17.086/433.98	31.787/807.39	19.132/485.95	33.833/859.36
2.27	12.240/310.90	26.941/684.30	13.811/350.80	28.512/724.20	14.856/377.34	29.557/750.75	16.920/429.77	31.621/803.17	18.971/481.86	33.672/855.27
2.46	11.941/303.30	26.642/676.71	14.042/356.67	28.743/730.07	15.087/383.21	29.788/756.62	17.154/435.71	31.855/809.12	19.205/487.81	33.906/861.21
2.68	12.169/309.09	26.870/682.50	13.746/349.15	28.447/722.55	14.793/375.74	29.494/749.15	16.865/428.37	31.566/801.78	18.923/480.64	33.624/854.05

ALL DIMENSIONS SHOWN AS INCH/MILLIMETER
 (INCH)
 (MILLIMETER)

AVAILABLE RATIO AND DROP DIMENSIONS

4X 1/2-13 UNC-2B X
1.187/30.16 DEEP
MOUNTING HOLES
ON 6.000/152.40 BC
(REMOVE EXISTING
SCREWS AND INSTALL
LONGER SCREWS TO
ACCOMMODATE BRACKET)

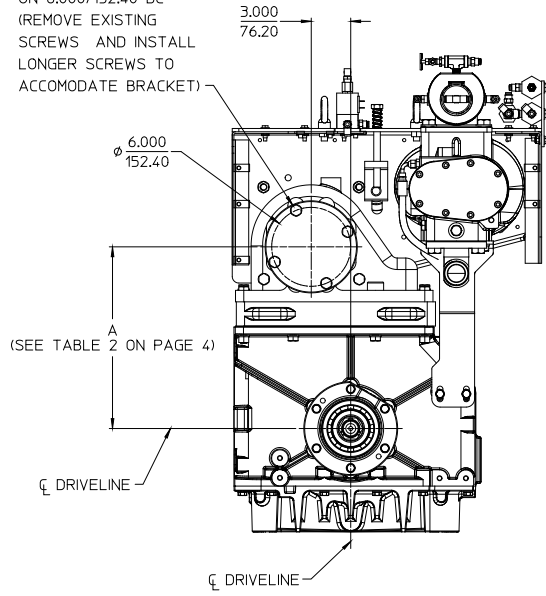

INPUT SIDE OF CASE

BRACKET MOUNTING
LOCATION ON INPUT
SIDE OF CASE

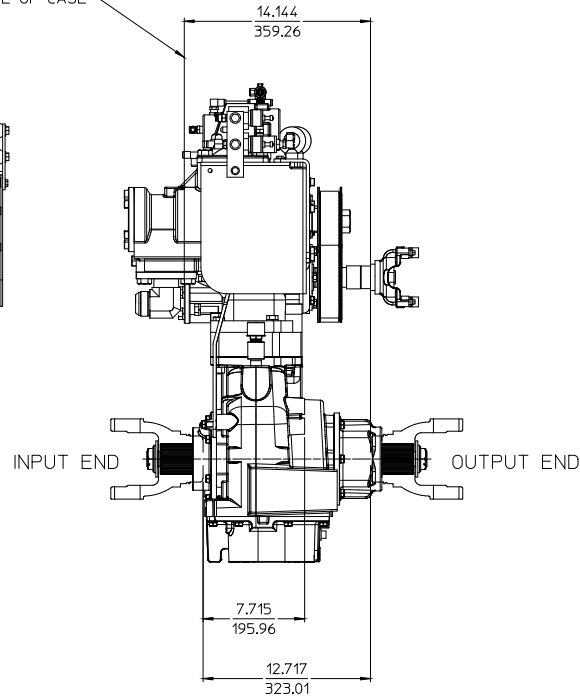

ALL DIMENSIONS SHOWN AS INCH/MILLIMETER
(INCH
MILLIMETER)

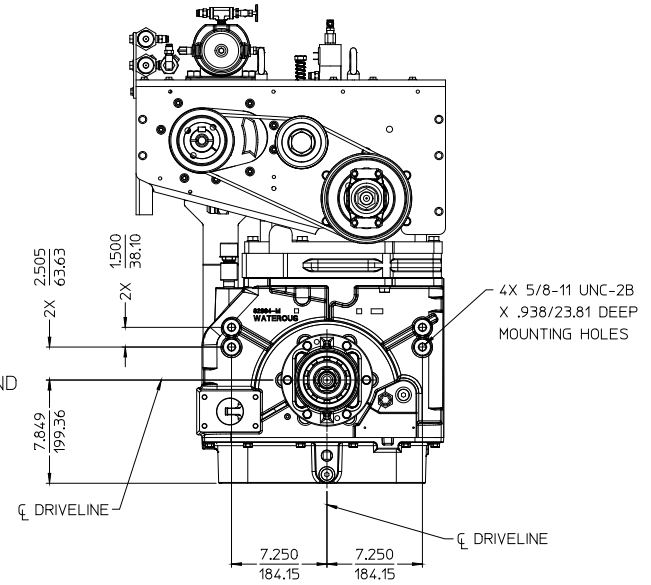

OUTPUT SIDE OF CASE

MOUNTING BRACKET ATTACHMENT LOCATIONS
BRACKETS NOT FURNISHED BY WATEROUS

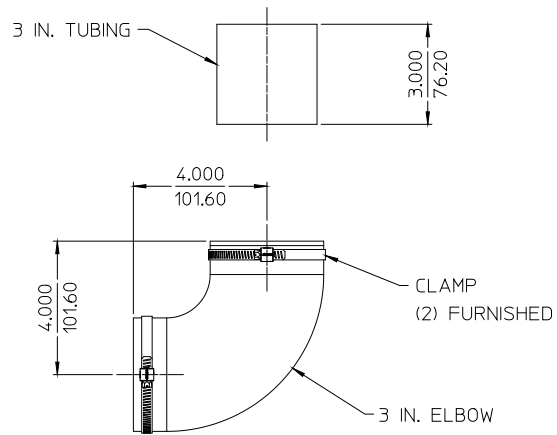
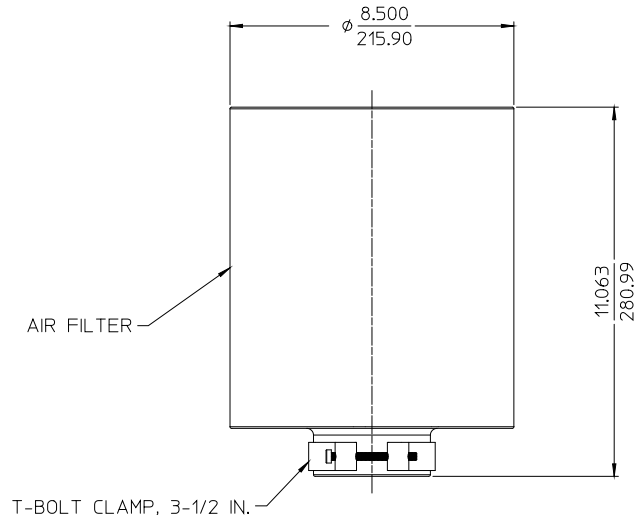

AIR FILTER

ALL DIMENSIONS SHOWN AS INCH/MILLIMETER

(INCH
MILLIMETER)

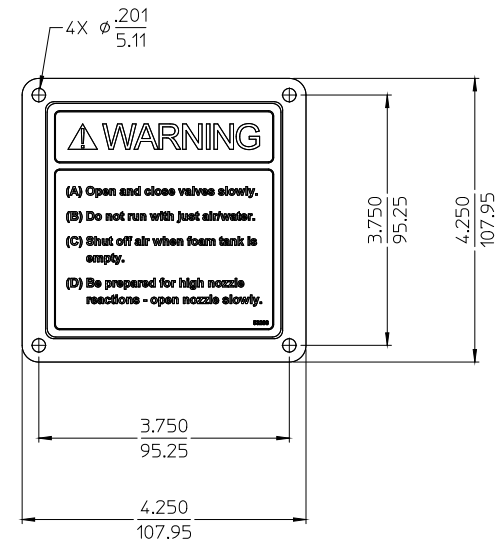
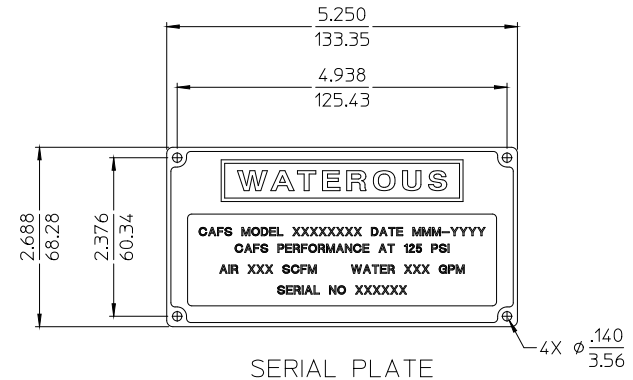

CAFS WARNING

PANEL PLATE

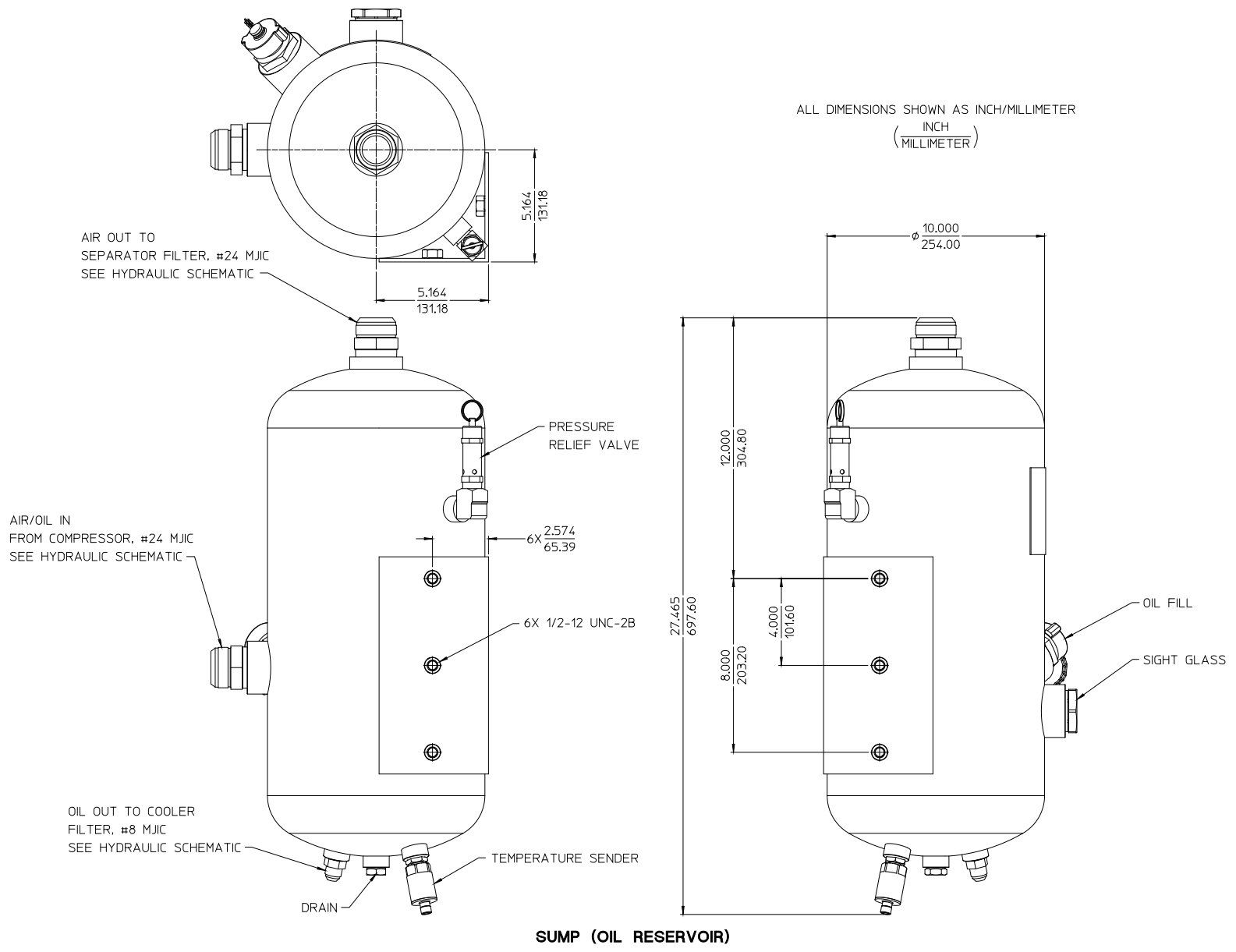

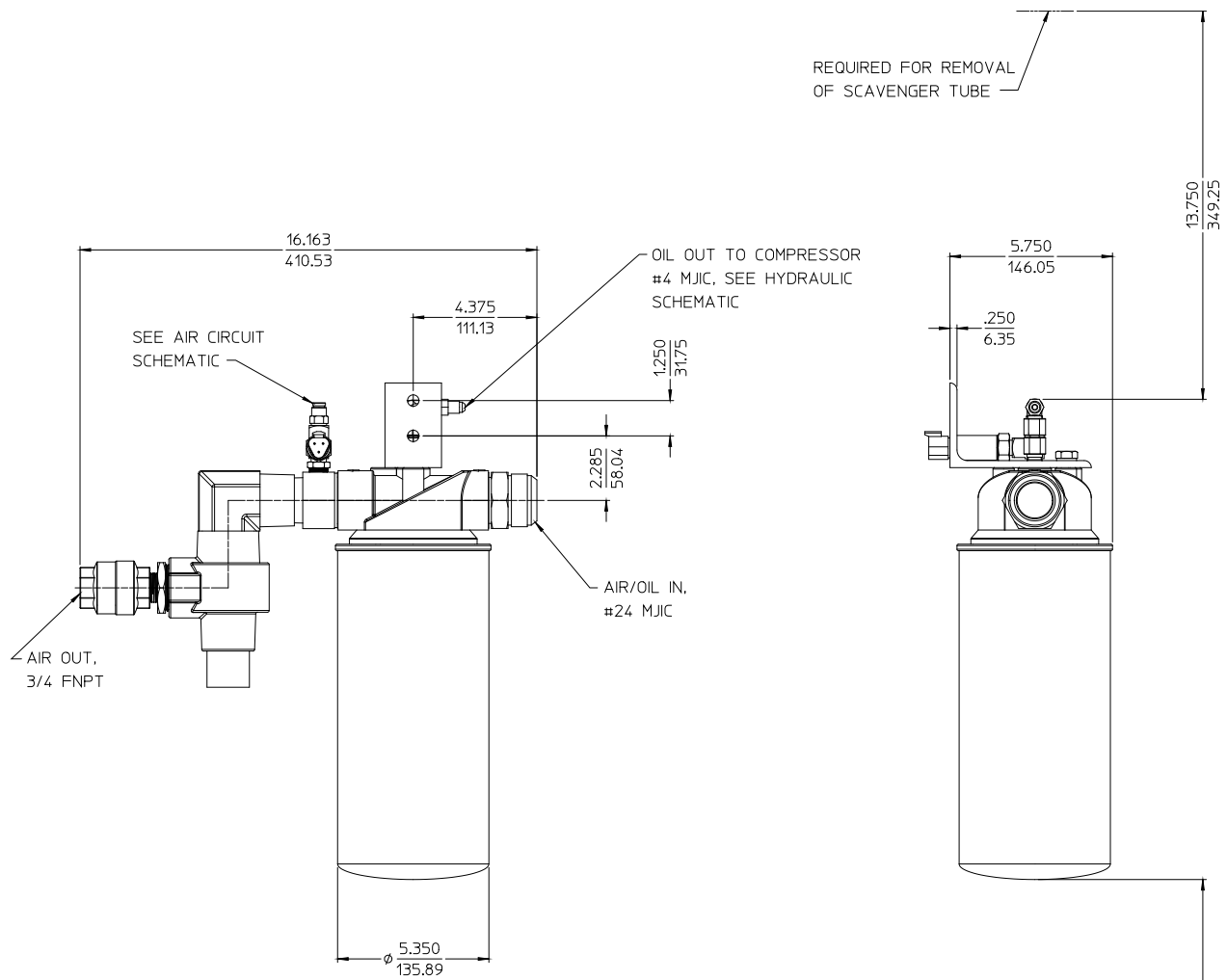

ALL DIMENSIONS SHOWN AS INCH/MILLIMETER
 (INCH)
 (MILLIMETER)

SEPARATOR FILTER

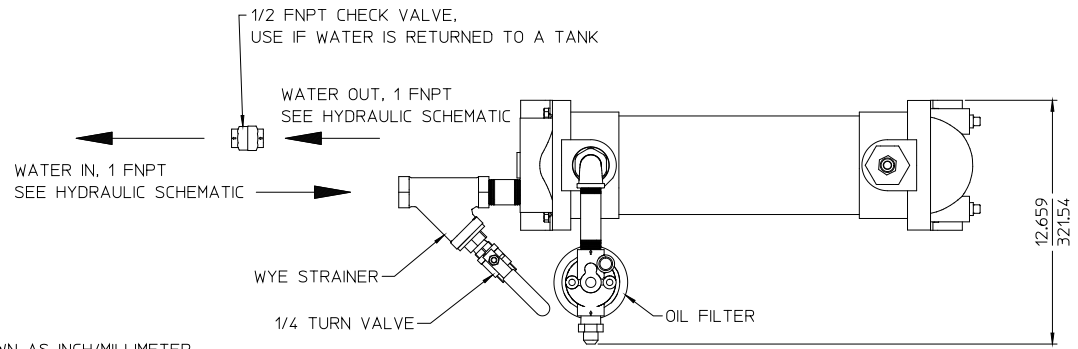

ALL DIMENSIONS SHOWN AS INCH/MILLIMETER
INCH
(MILLIMETER)

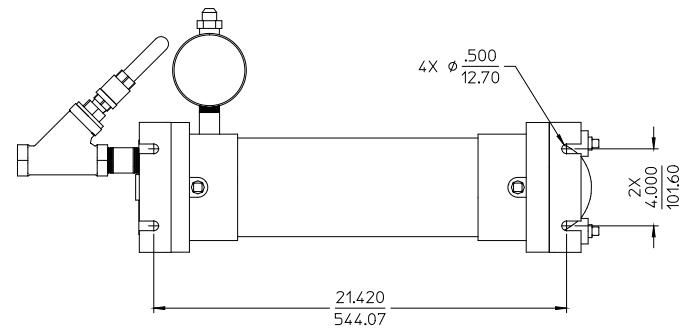
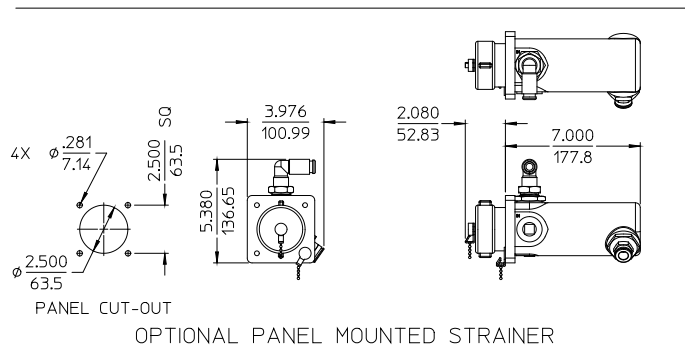
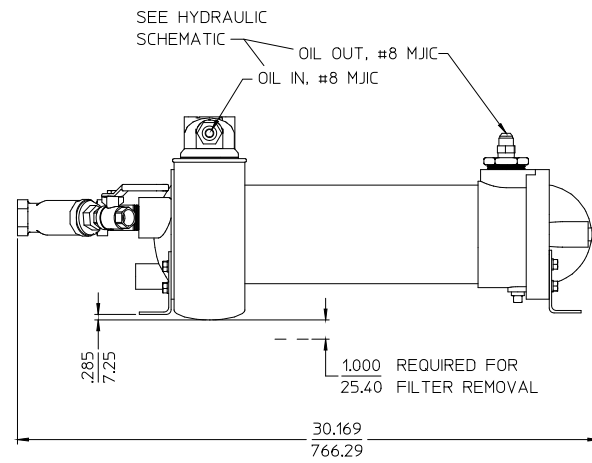
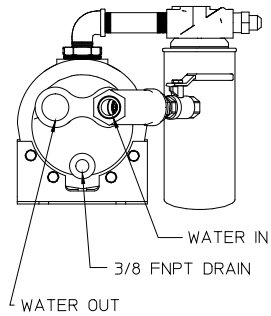

OIL COOLER

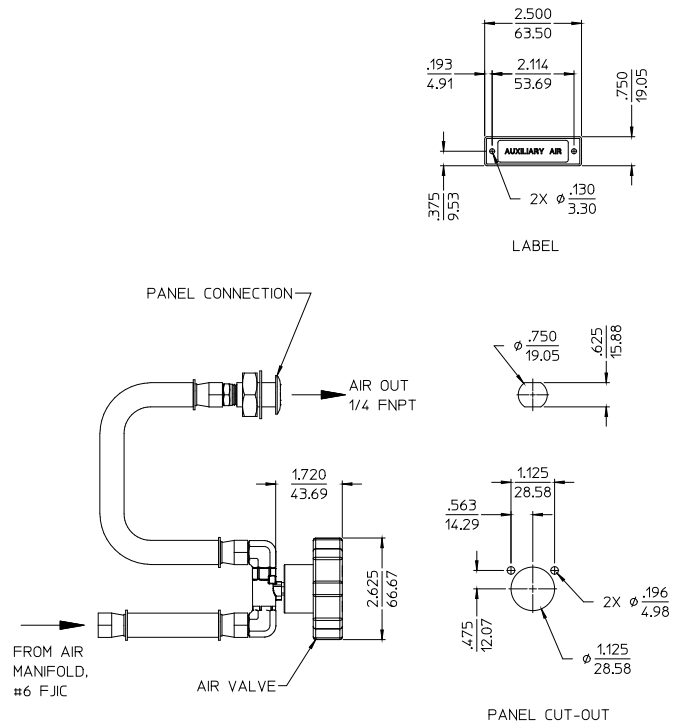

1/4 FNPT CONNECTION
 (HOSES AND FITTINGS FURNISHED)
 ORDER PART NO. 83360-3A

ALL DIMENSIONS SHOWN AS INCH/MILLIMETER
 (INCH / MILLIMETER)

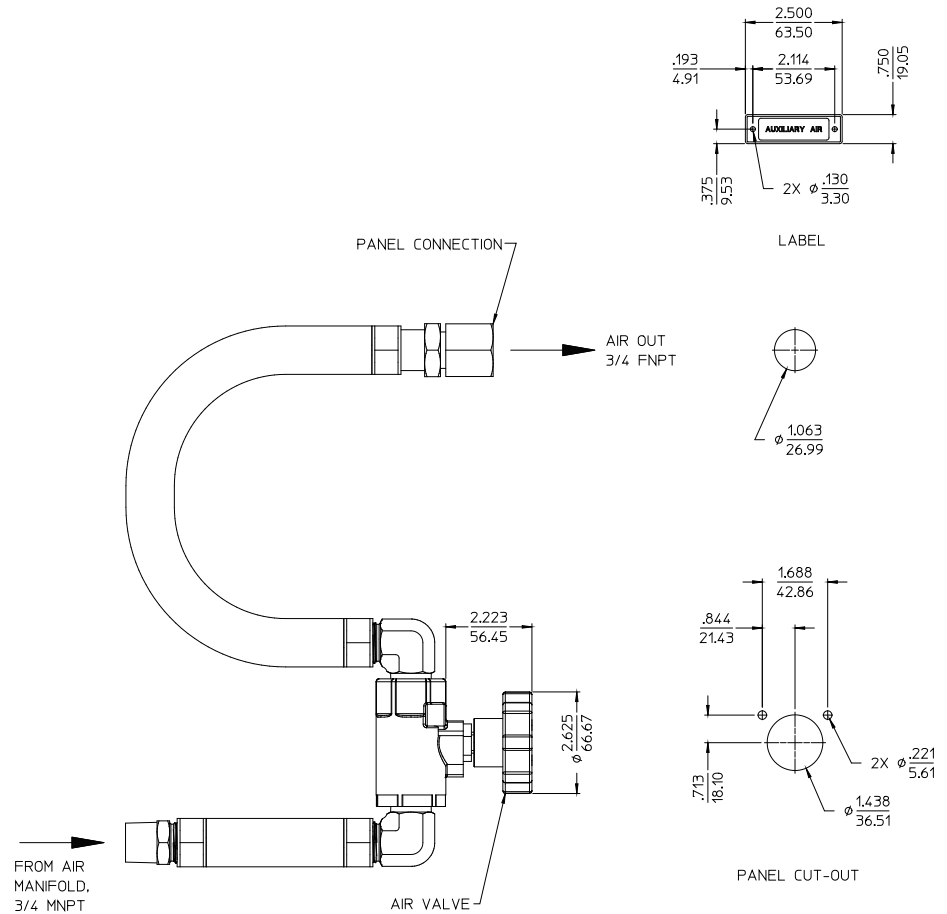

3/4 NPT CONNECTION
 (HOSES AND FITTINGS FURNISHED)
 ORDER PART NO. 83360-3B

OPTIONAL AUXILIARY AIR CONNECTION

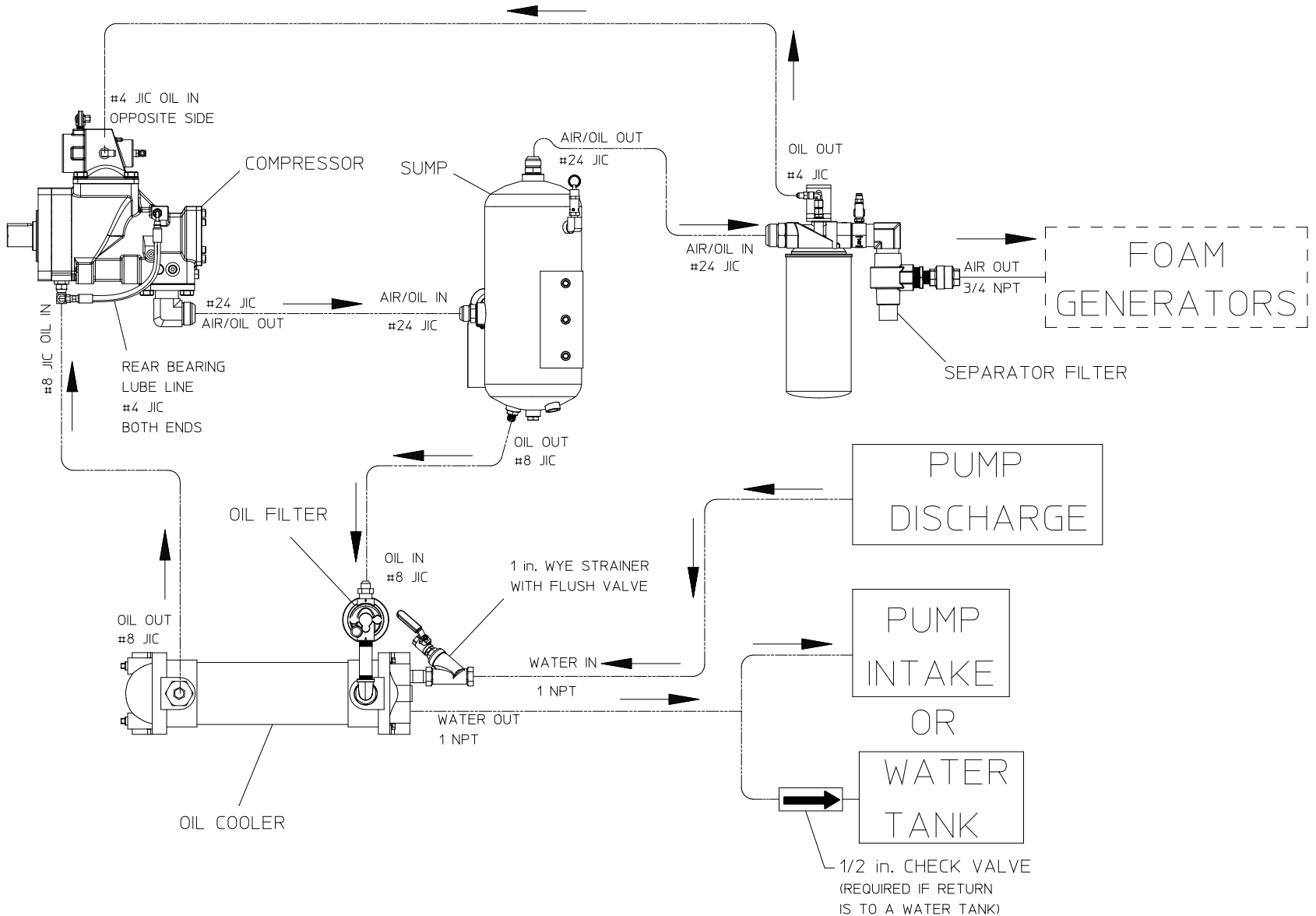

SCHEMATIC - HYDRAULIC
IN-LINE STRAINER

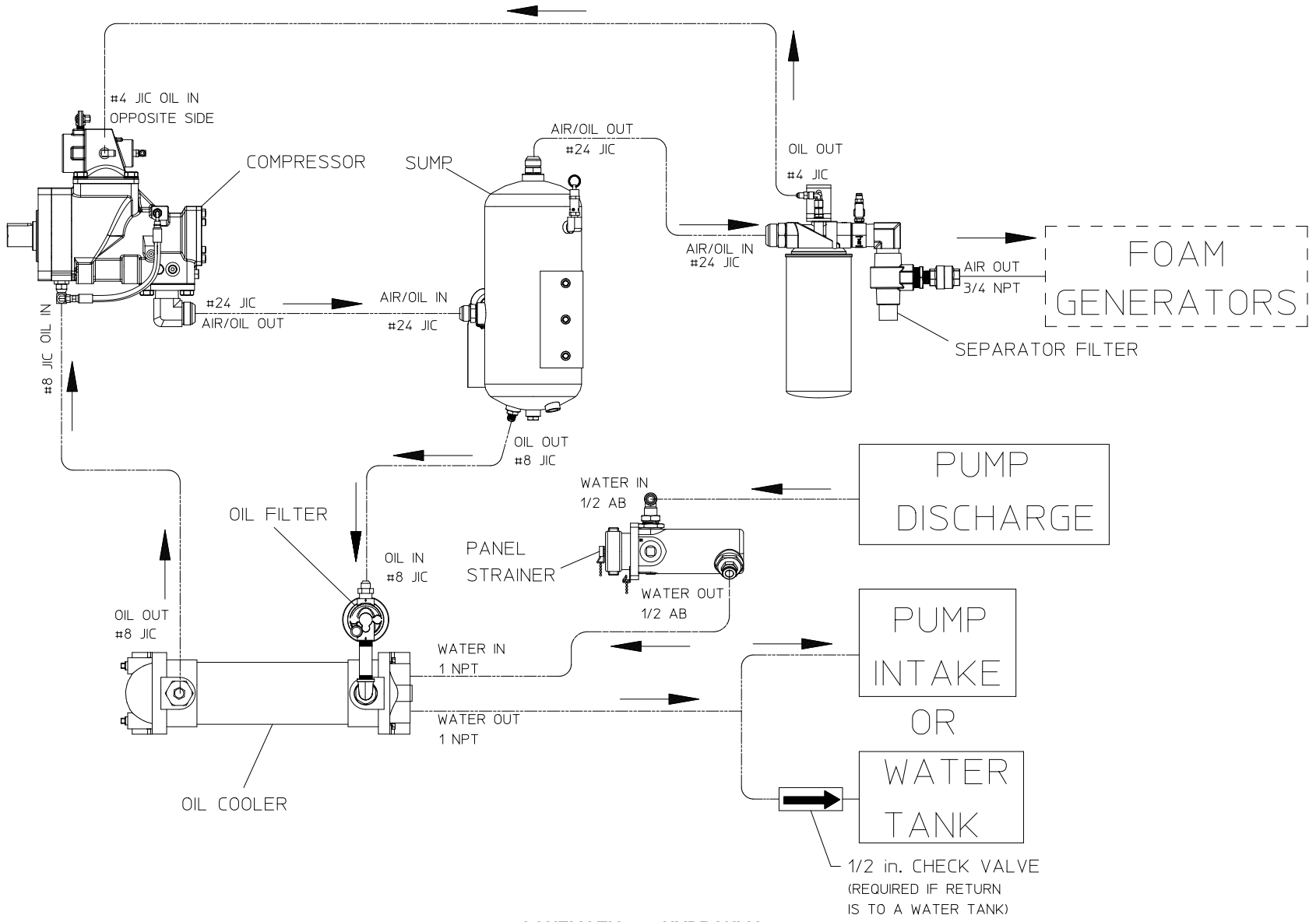

SCHEMATIC – HYDRAULIC
PANEL STRAINER

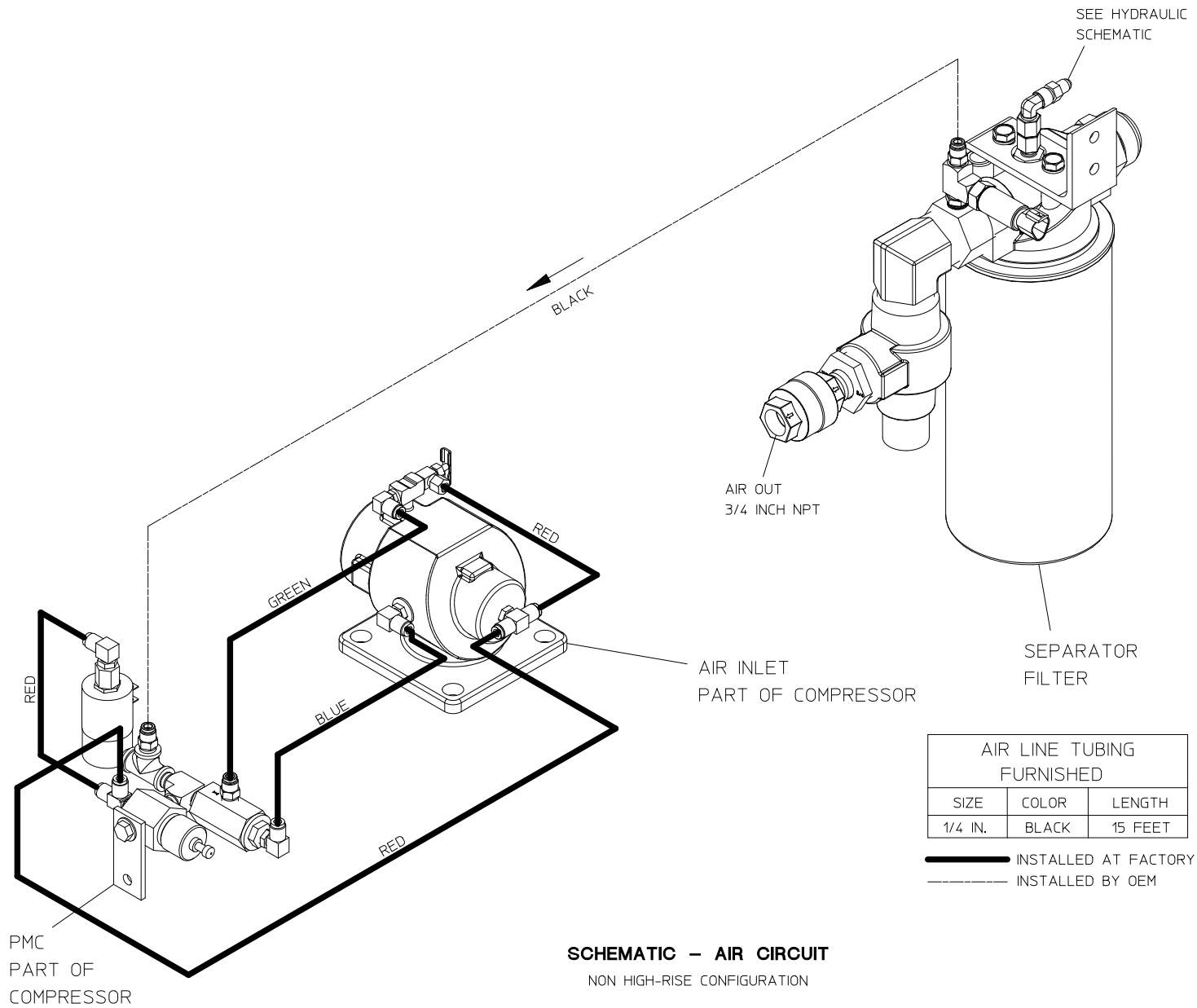

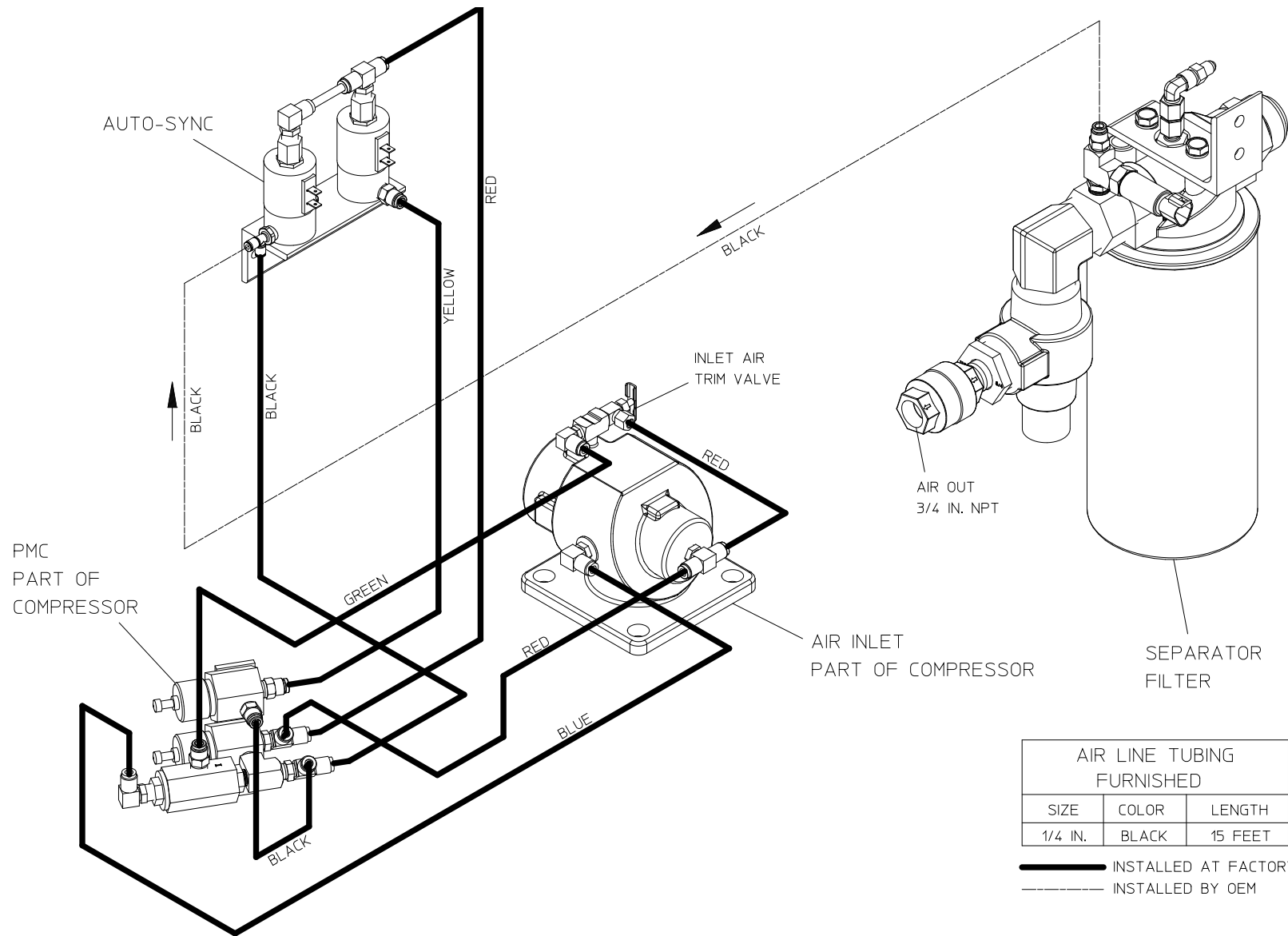

SCHEMATIC – AIR
 HIGH RISE CONFIGURATION