

HLU Series Pump Dimensional Drawings

Pump Model	Drive			Impeller Rotation (2)	See Page										
	Type	Input Shaft	Input Rotation (1)		Pump and Transmission			Available			Optional				
					Pump with Manual Crossover Valve Actuator	Pump with Pneumatic Crossover Valve Actuator	Transmission Mounting Positions	Intake Connection		Discharge Manifold	Auxiliary Fittings	Remotely Mounted RTP Foam System	External High Pressure Relief Valve	Gauges	Pressure Mode Controller
Standard	Short														
HLUD	Direct Drive	1410 Series Companion Flange (1-3/8-10 SAE Spline)	CW	CCW	2	--	--	11	12	13	14	See DPL83197	15	15	15
			CCW	CW	3	4									
HLUK	Heavy Duty K Series Transmissions	1-3/8-10 SAE Spline	CW	CW	5	7	10	11	12	13	14	See DPL83197	15	15	15
			CCW	CCW	6	--	10								
HLUPA	PA Series Transmission	1-1/2-10 SAE Spline	CW	CW	8	9	--								

- Notes:
1. Drive input rotation defined as viewed looking directly at direct drive or transmission input shaft.
 2. Impeller rotation defined as viewed looking directly into impeller eye from intake end of pump.

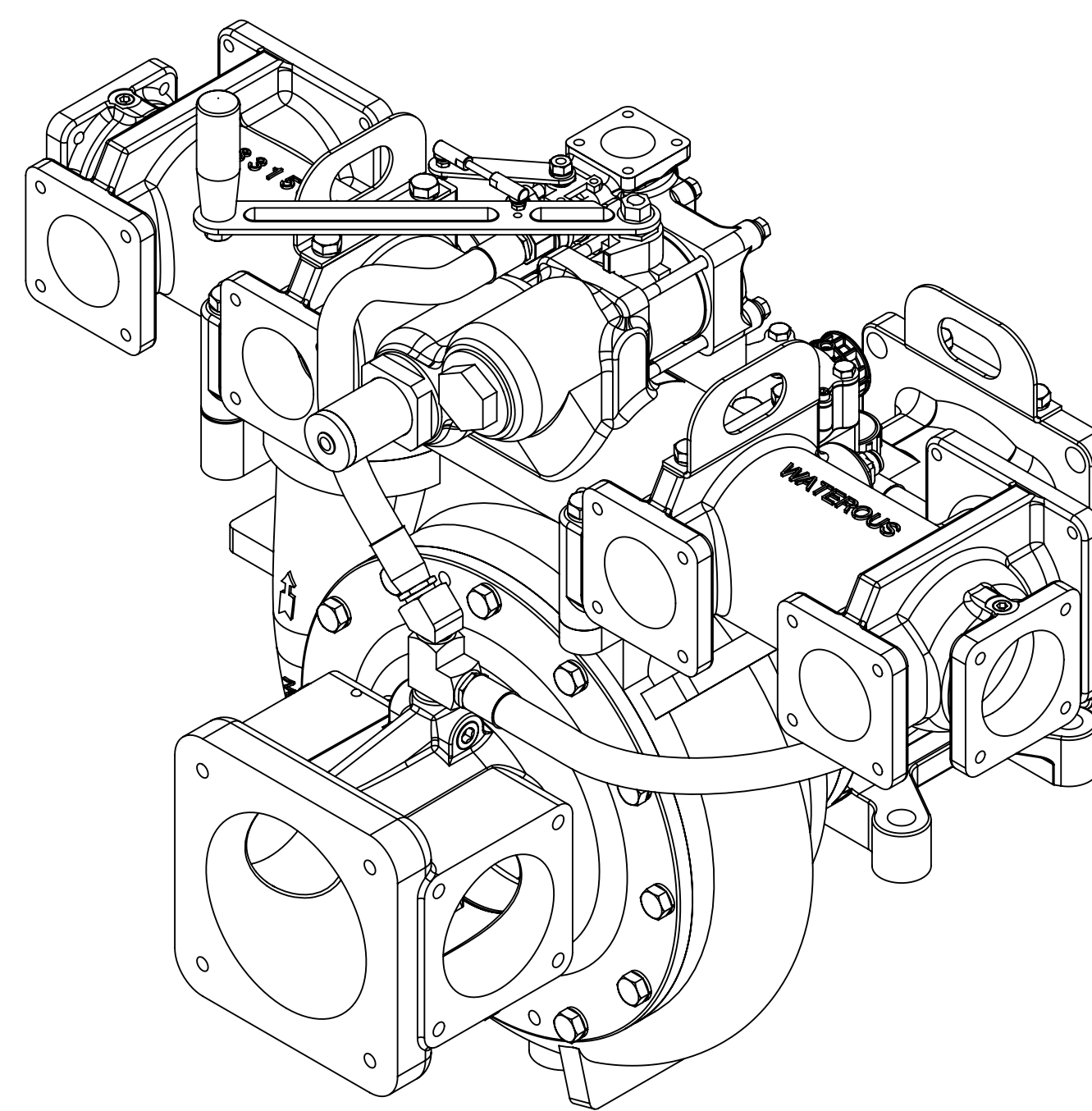

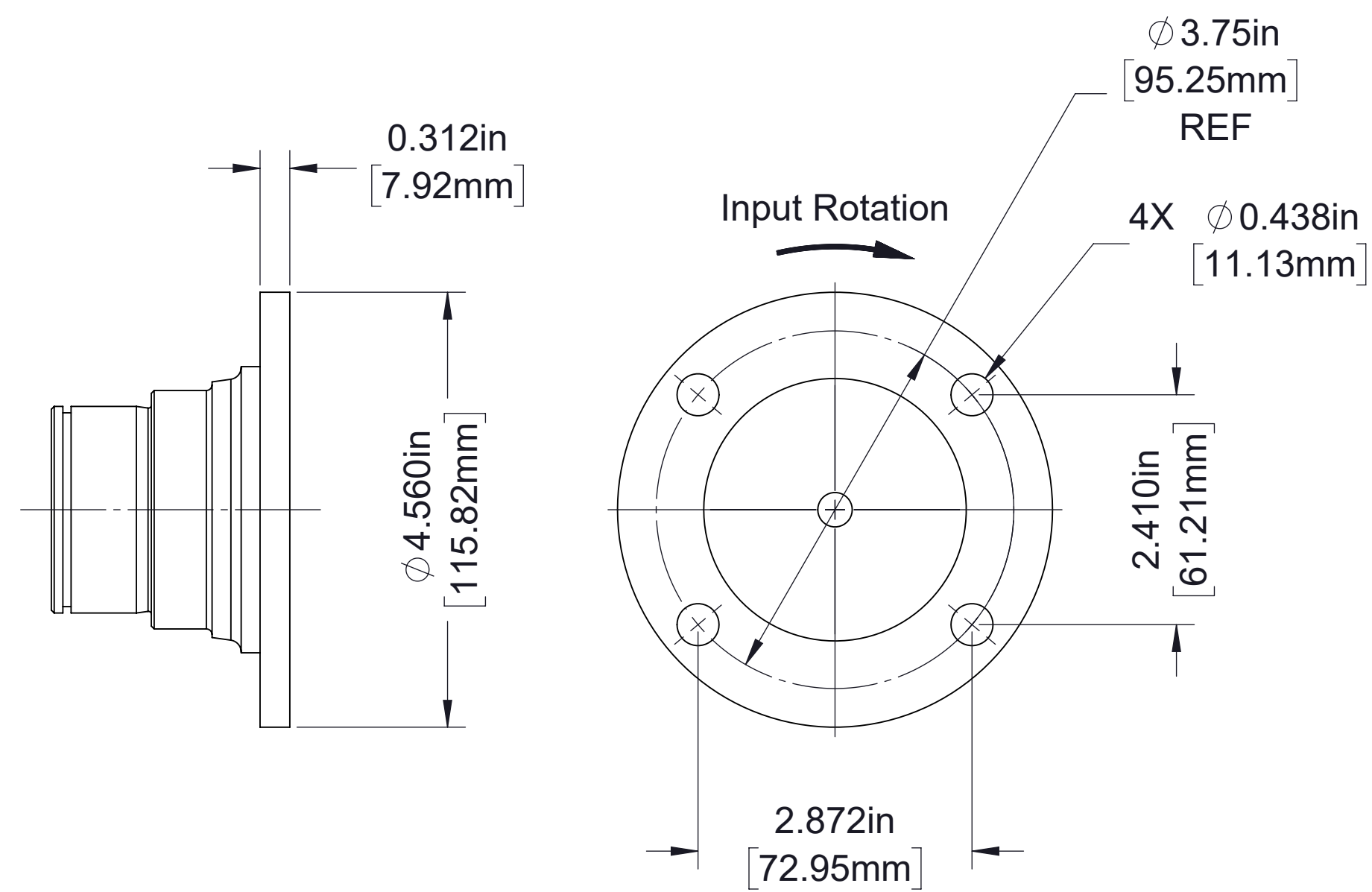

1410 Series Companion Flange Detail

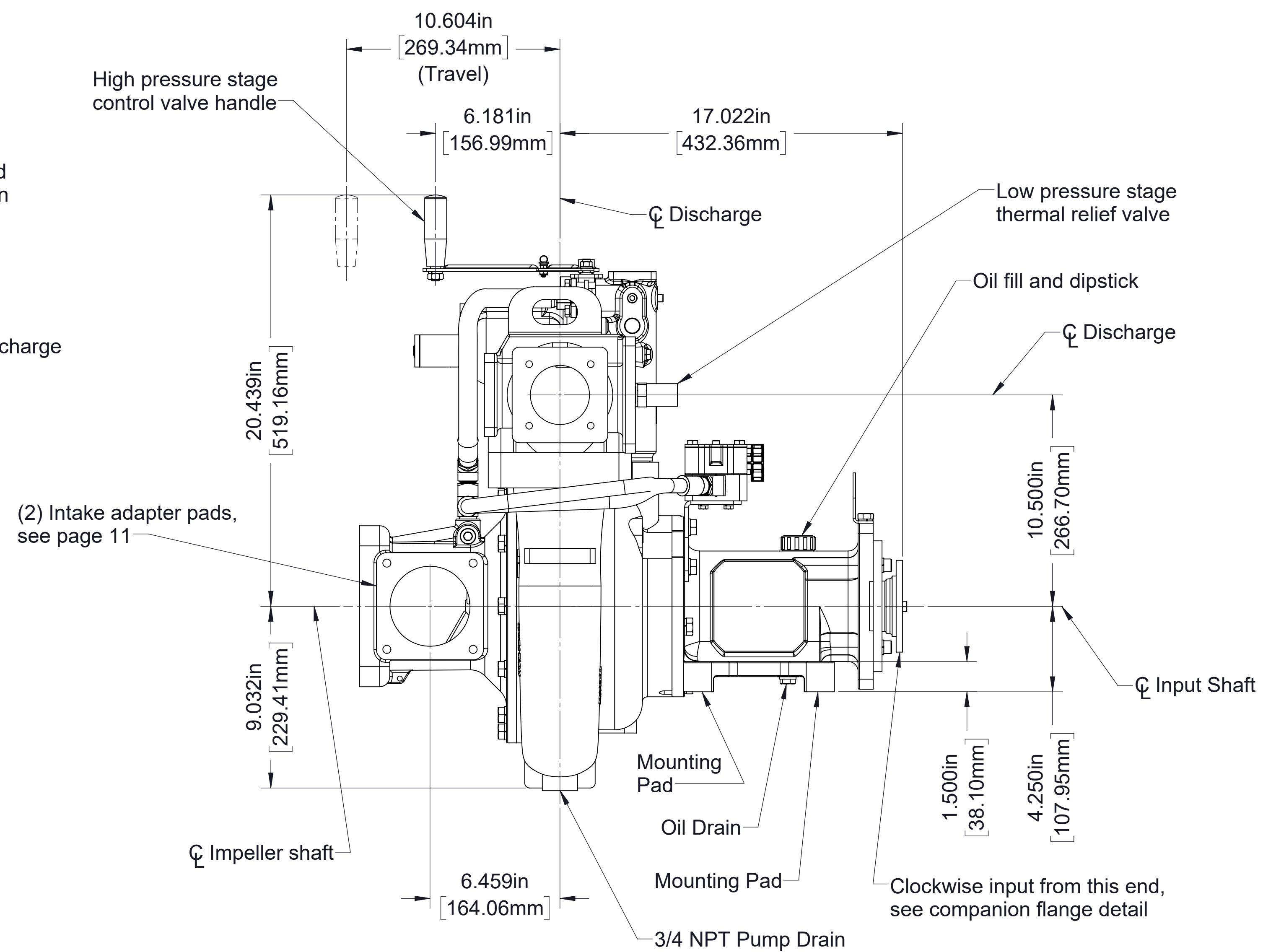
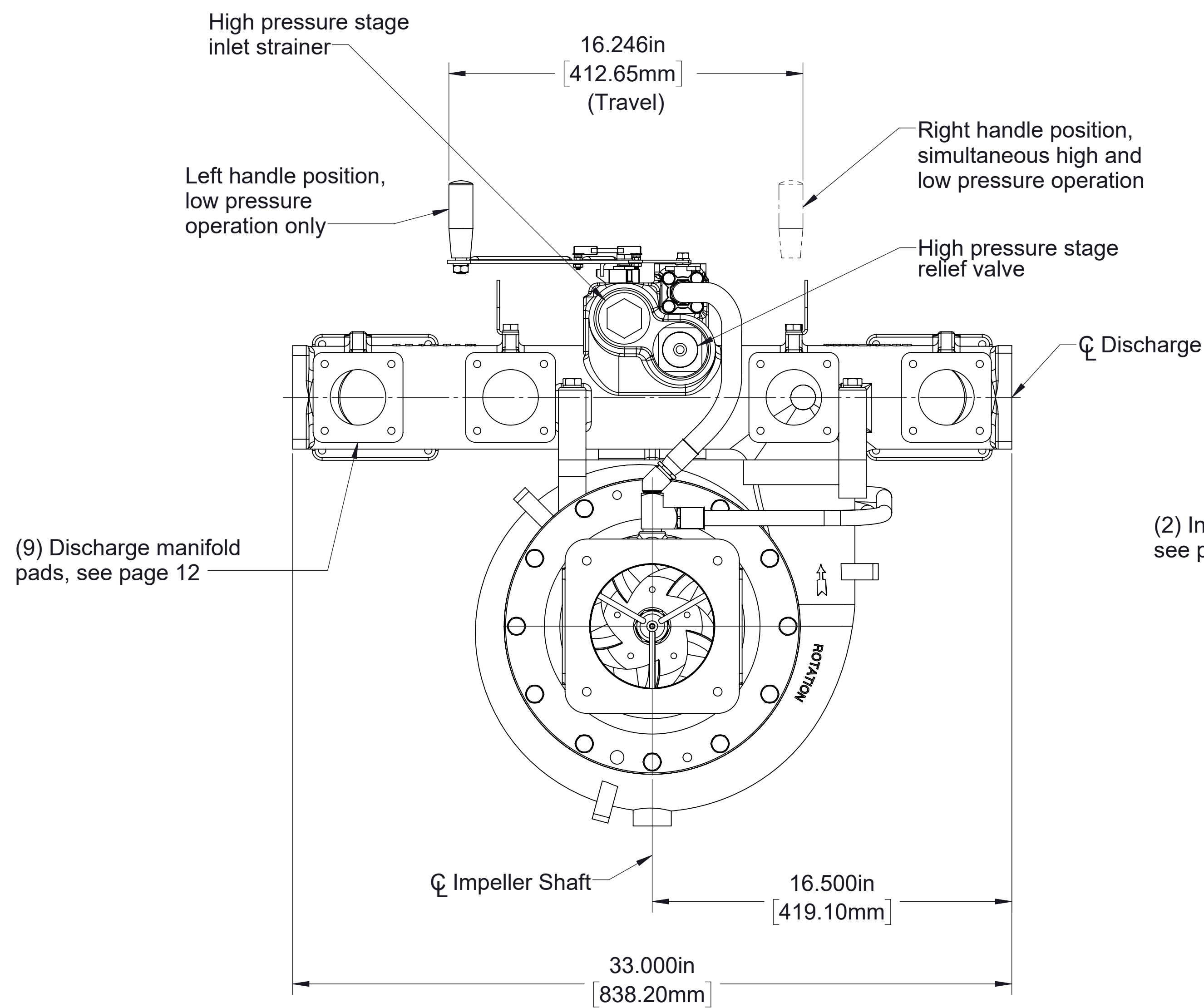
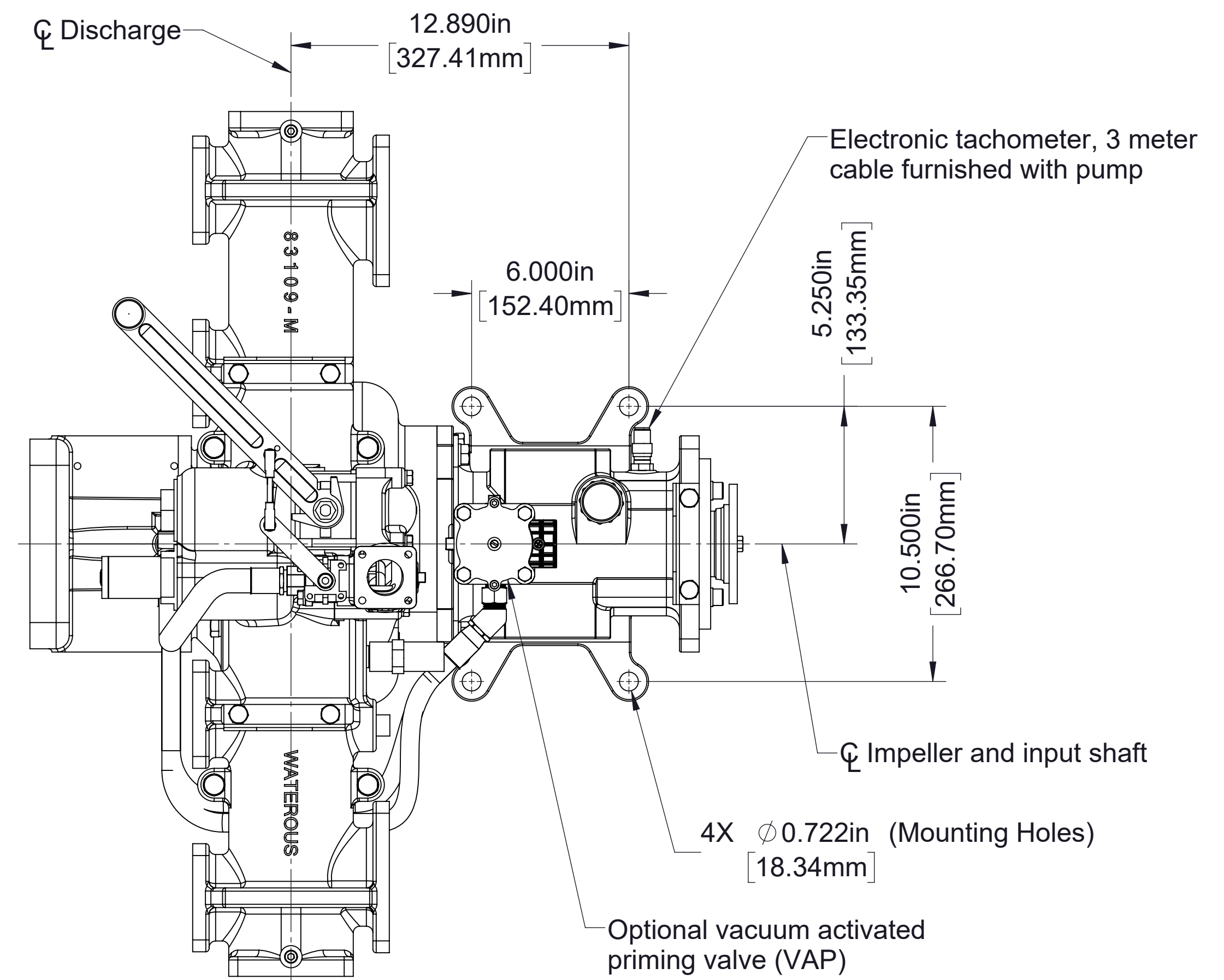

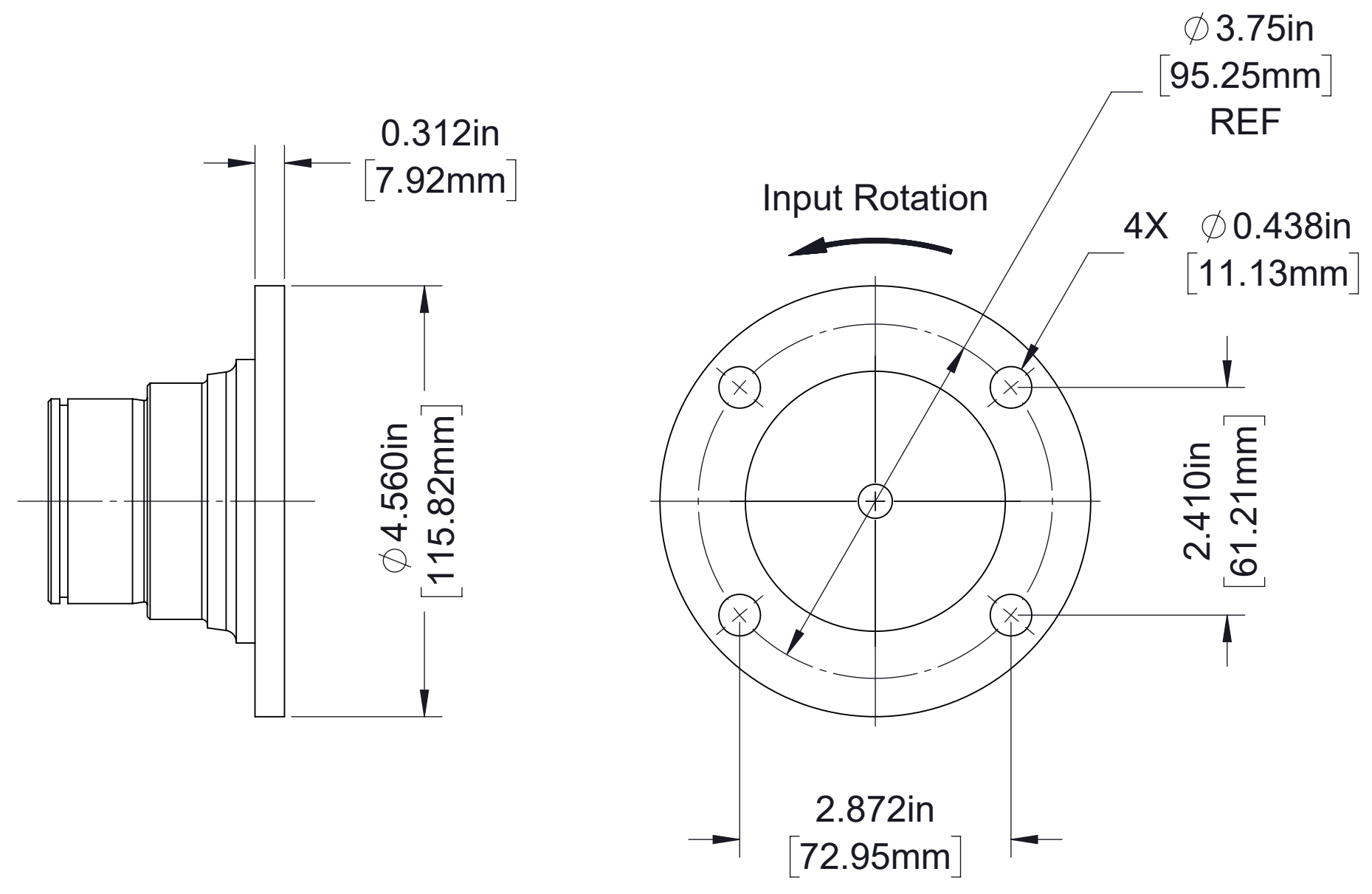

1410 Series Companion Flange Detail

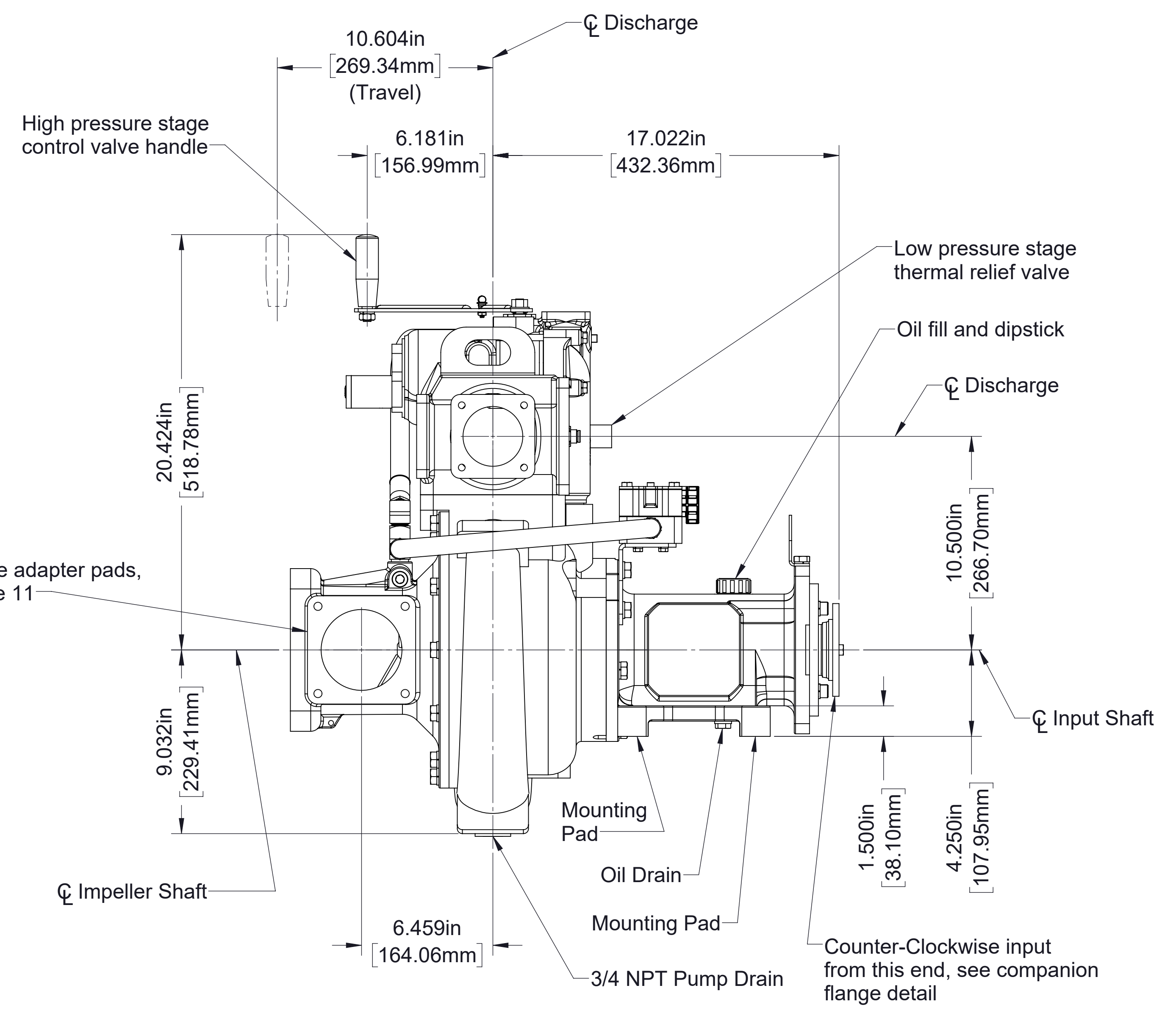
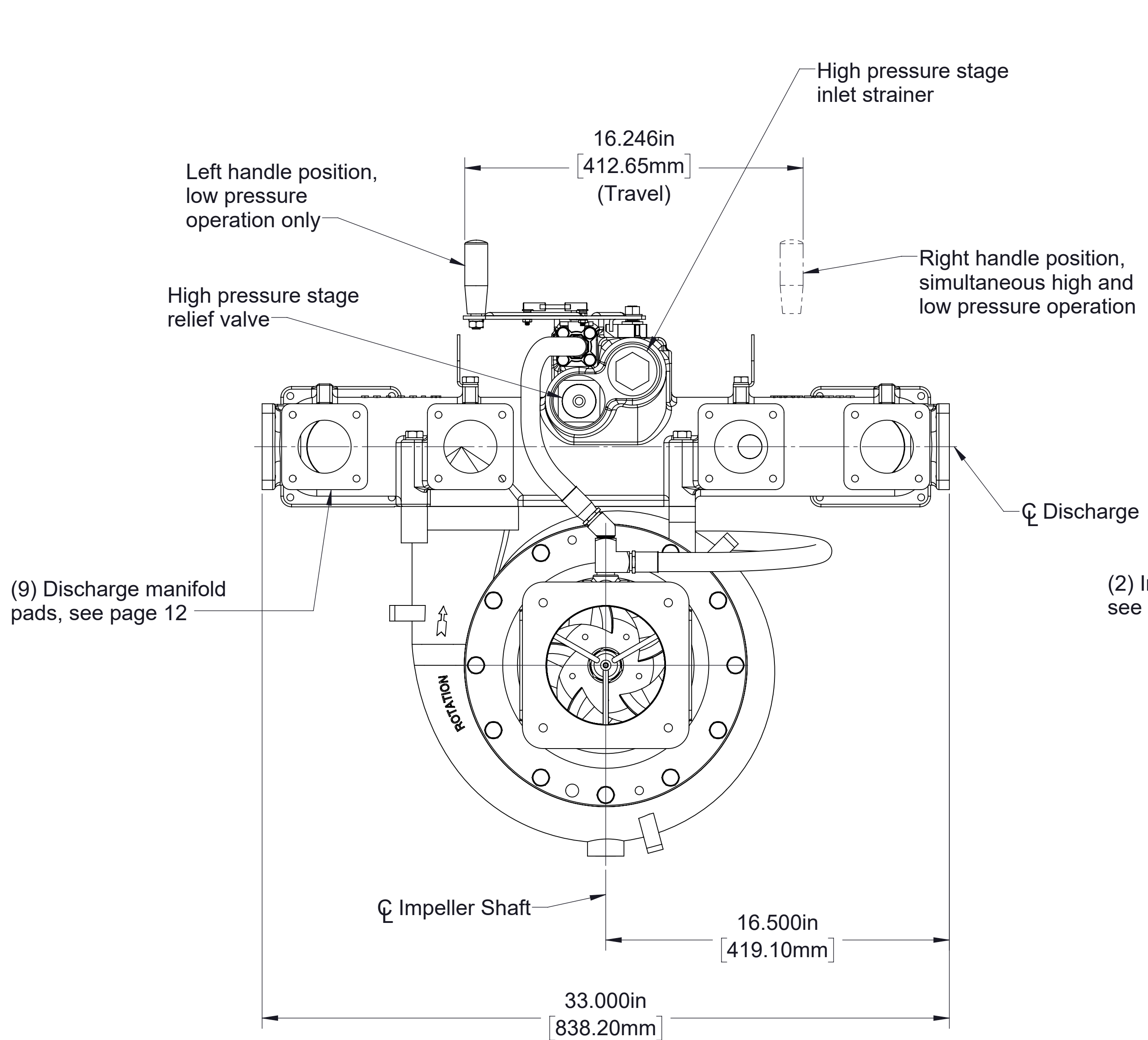
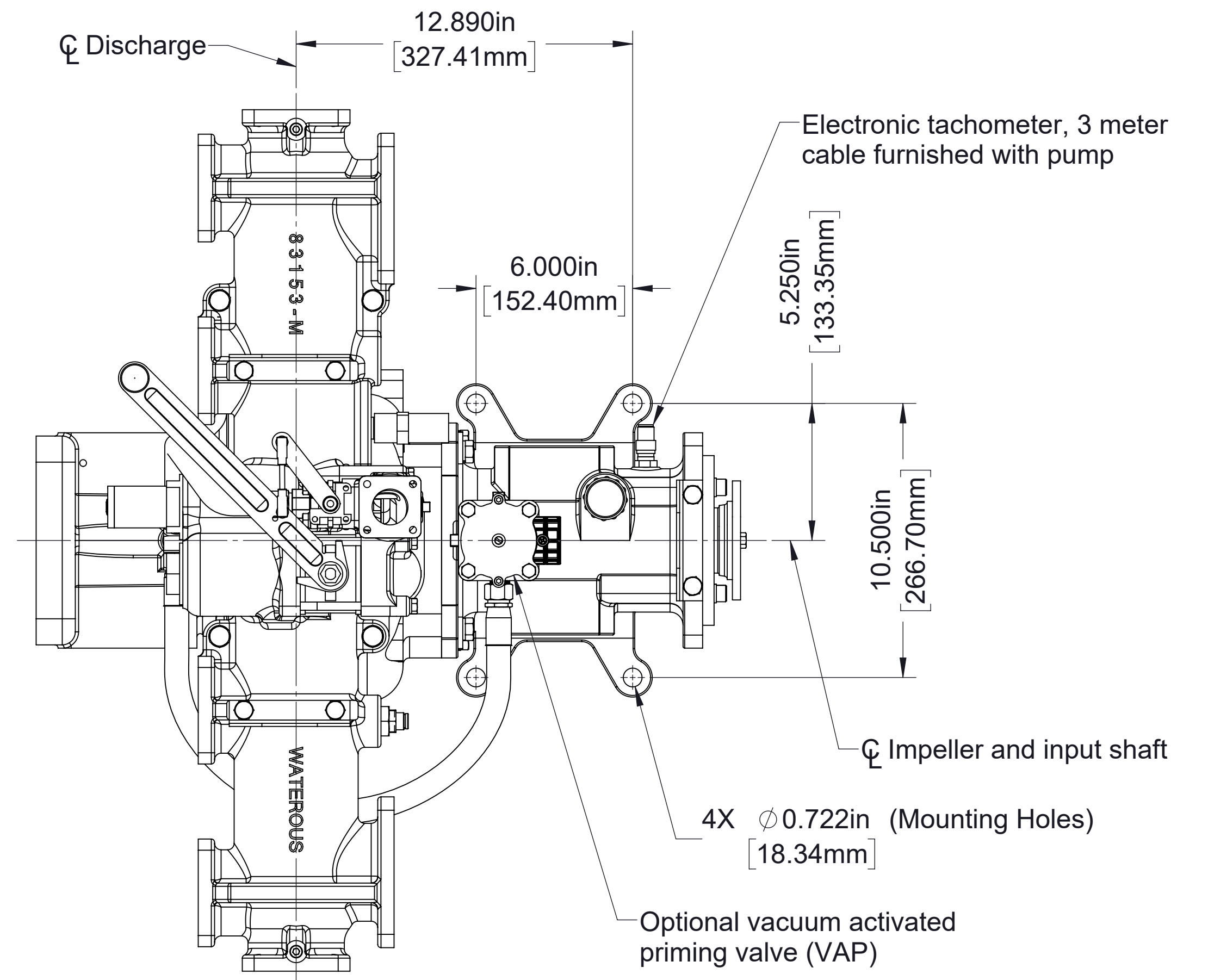

HLUD Pump with Manual Crossover Valve Actuator
Counter-Clockwise Input Rotation

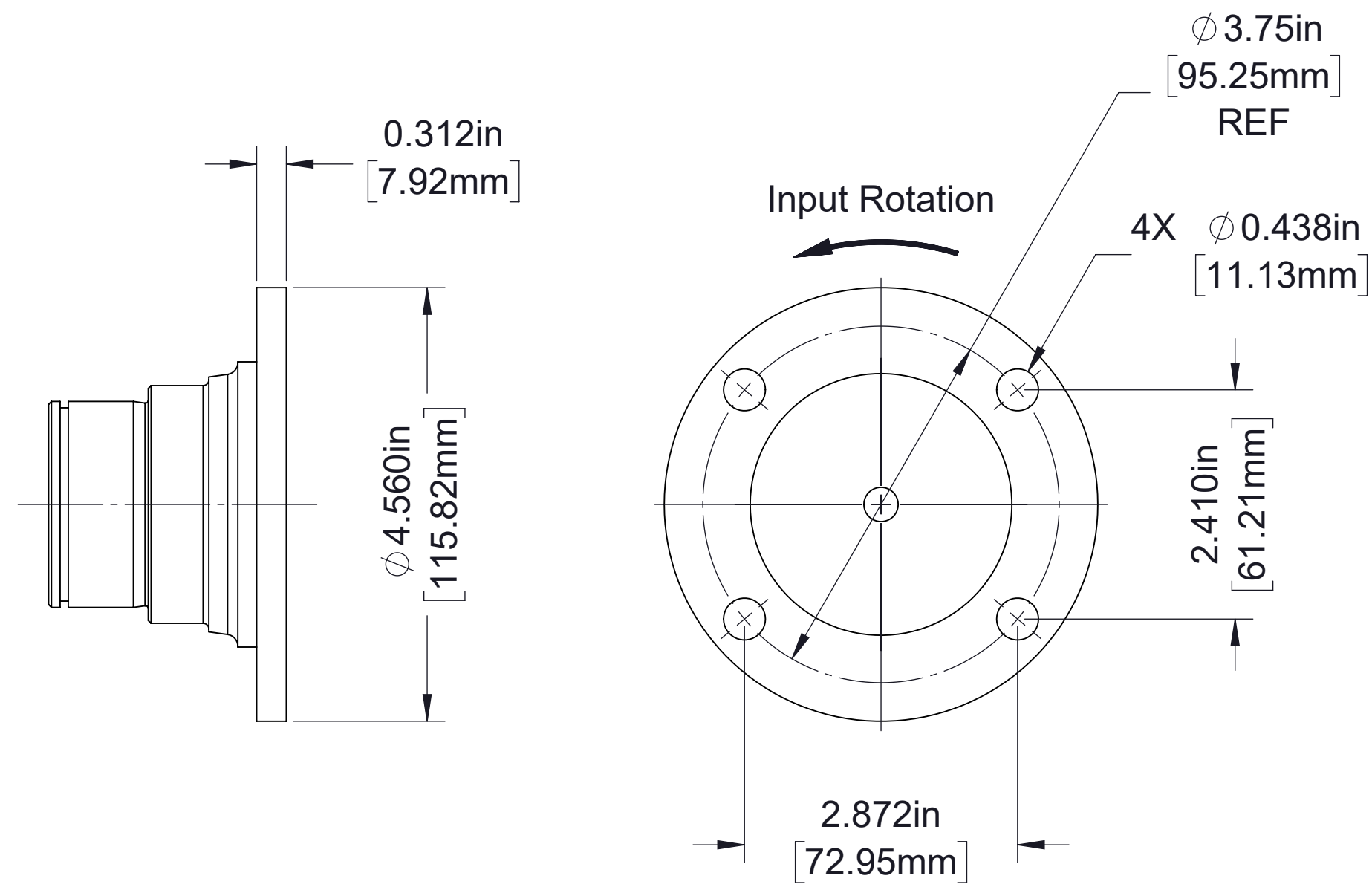

1410 Series Companion Flange Detail

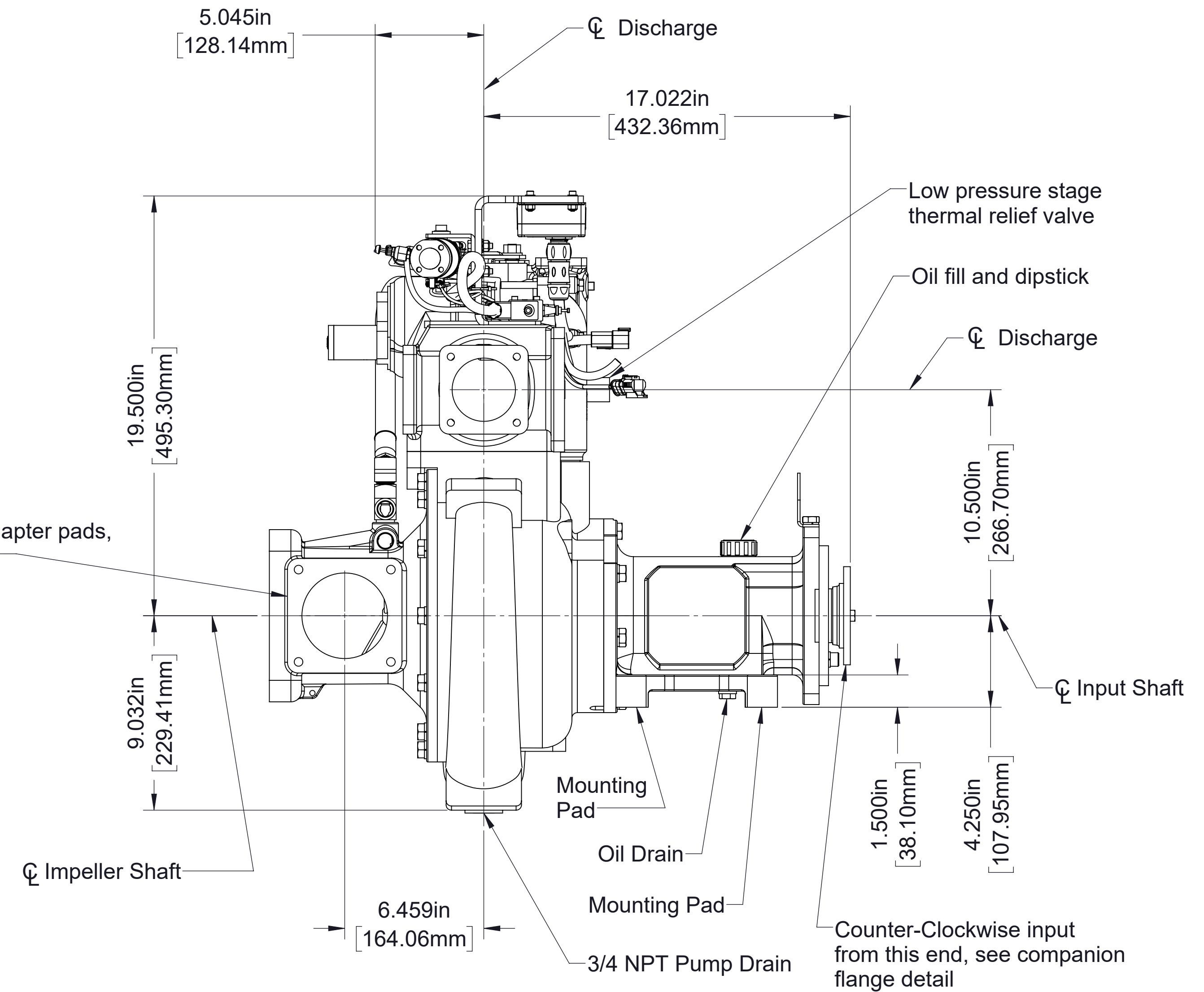
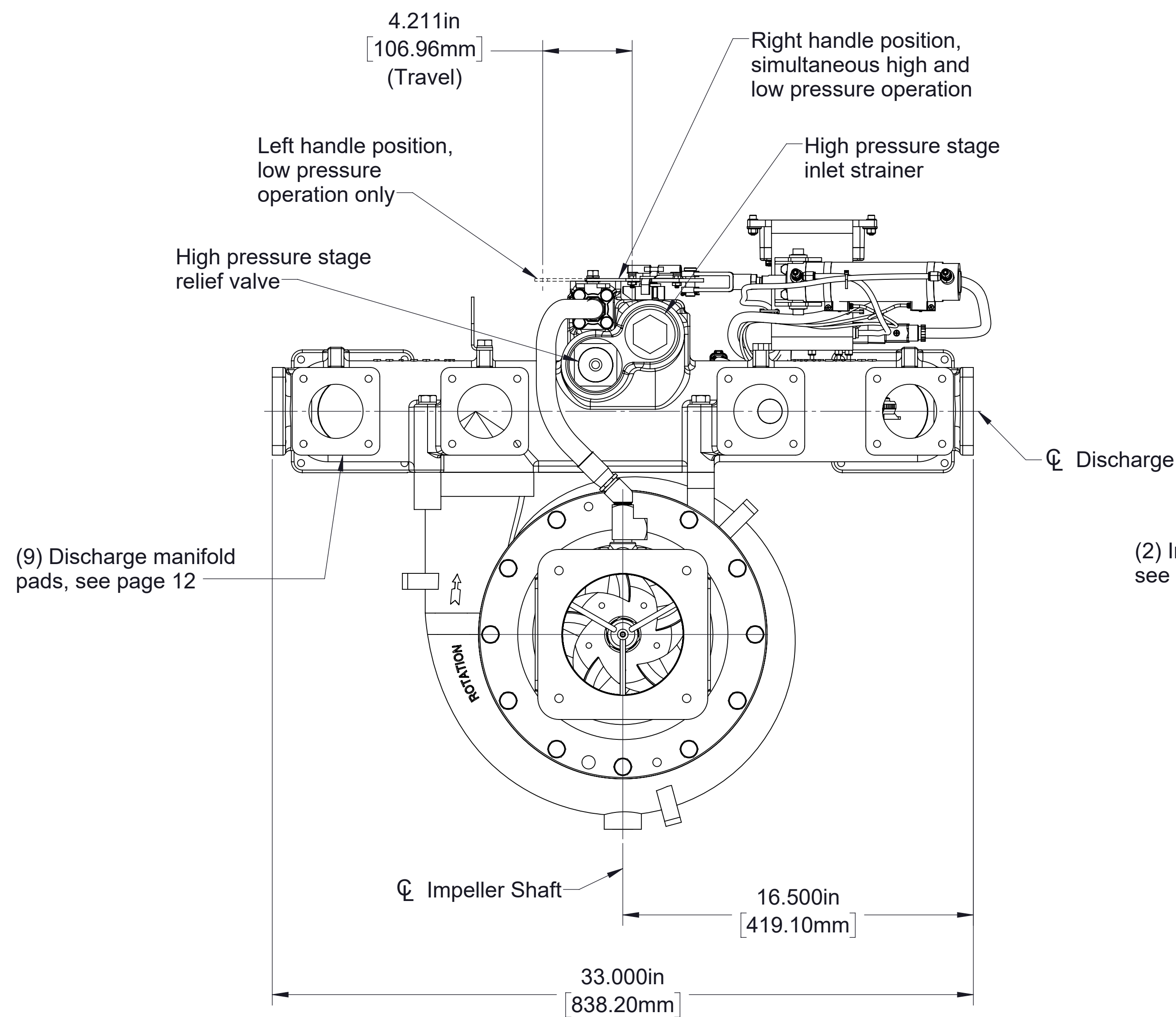
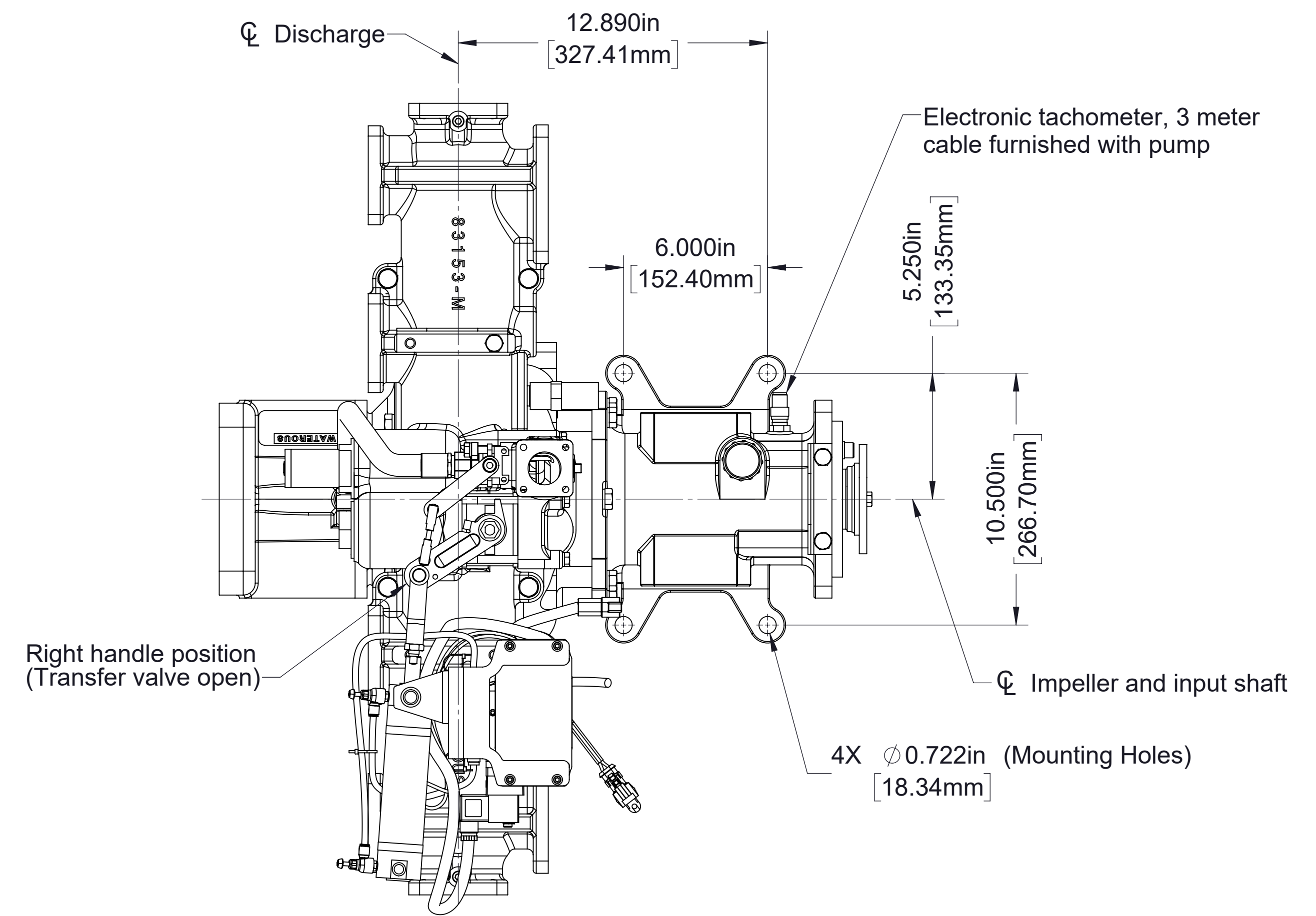

HLUD Pump with Pneumatic Crossover Valve Actuator
Counter-Clockwise Input Rotation

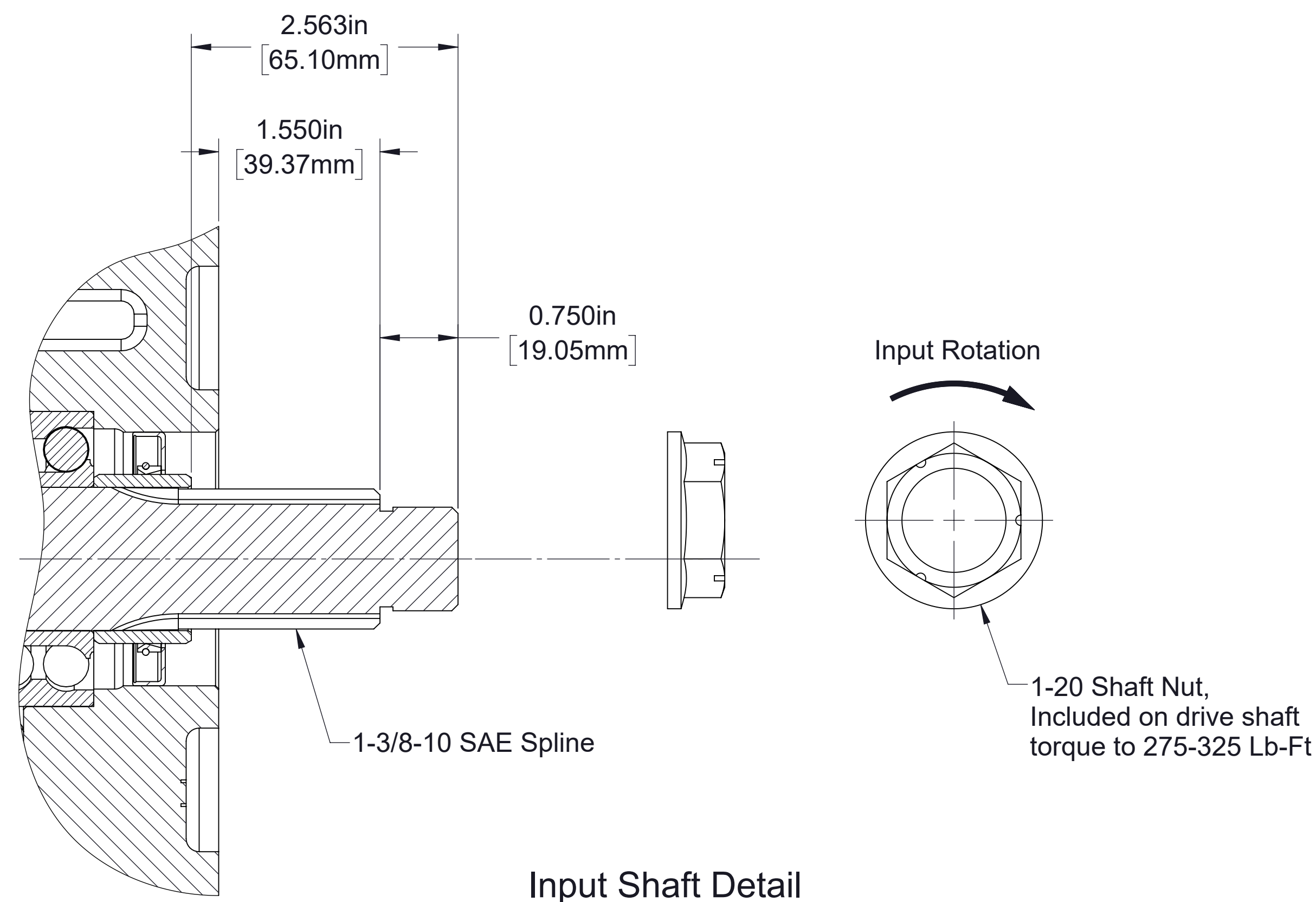

Input Shaft Detail

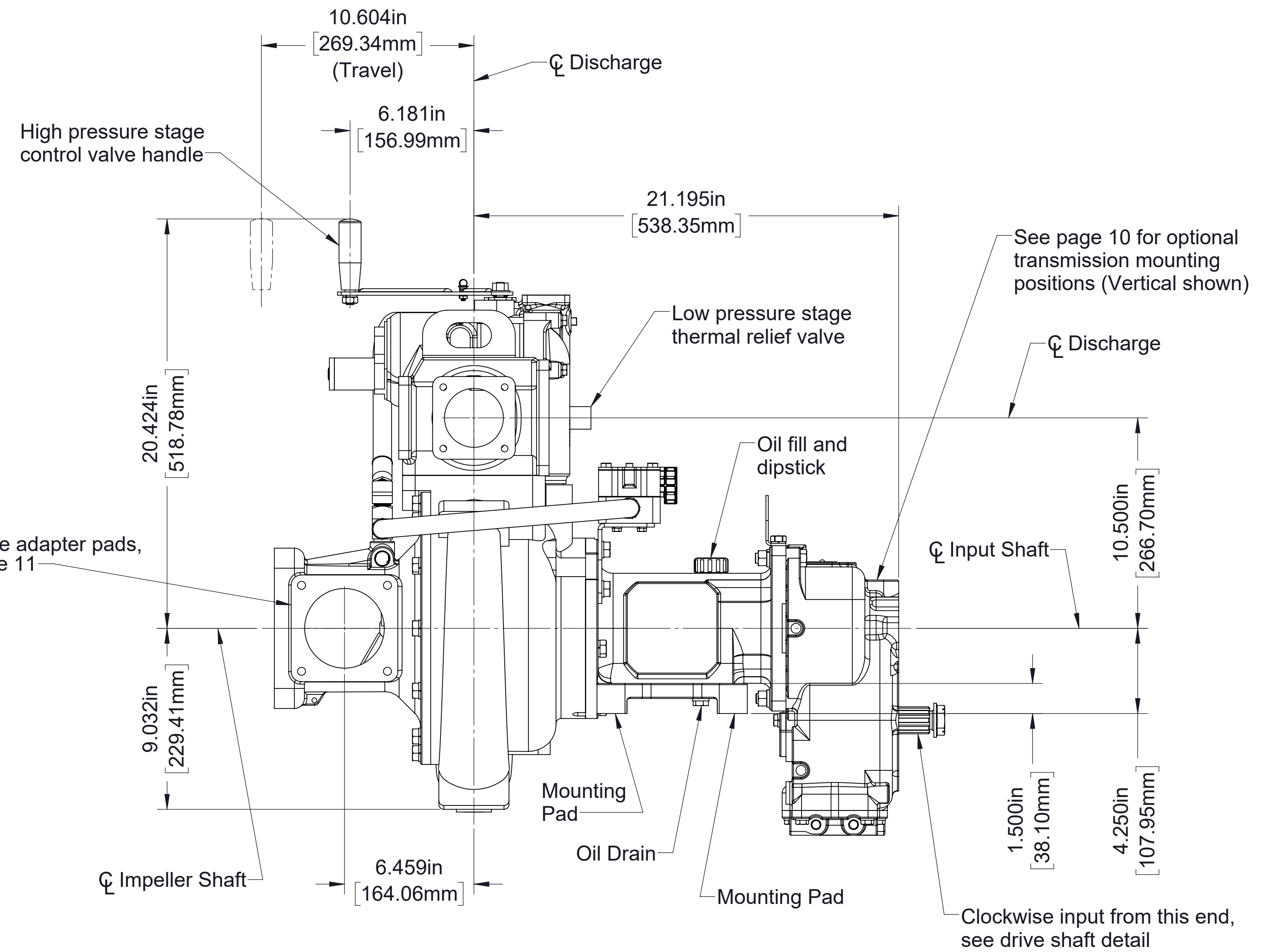
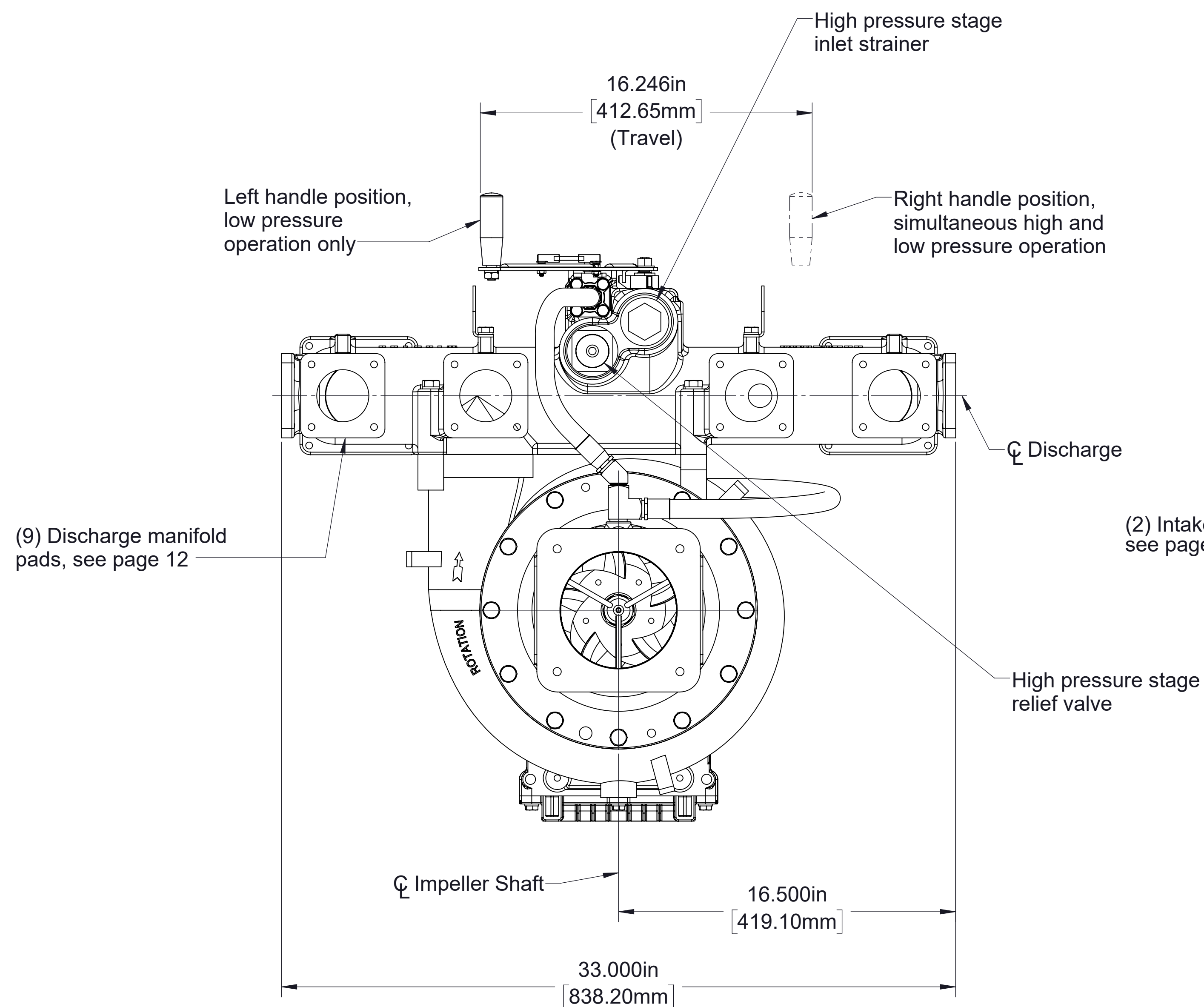
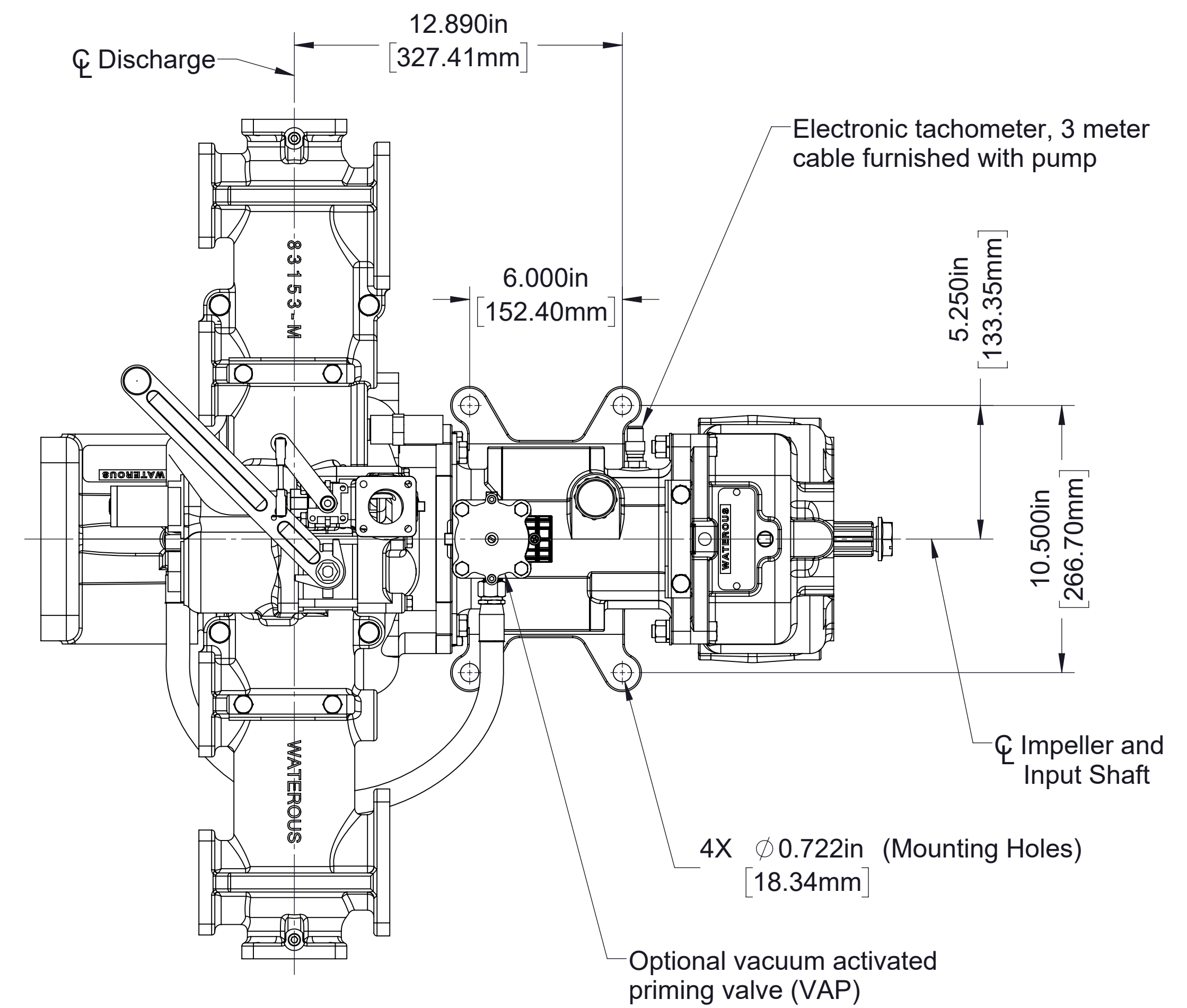

HLUK Pump with Manual Crossover Valve Actuator
Clockwise Input Rotation

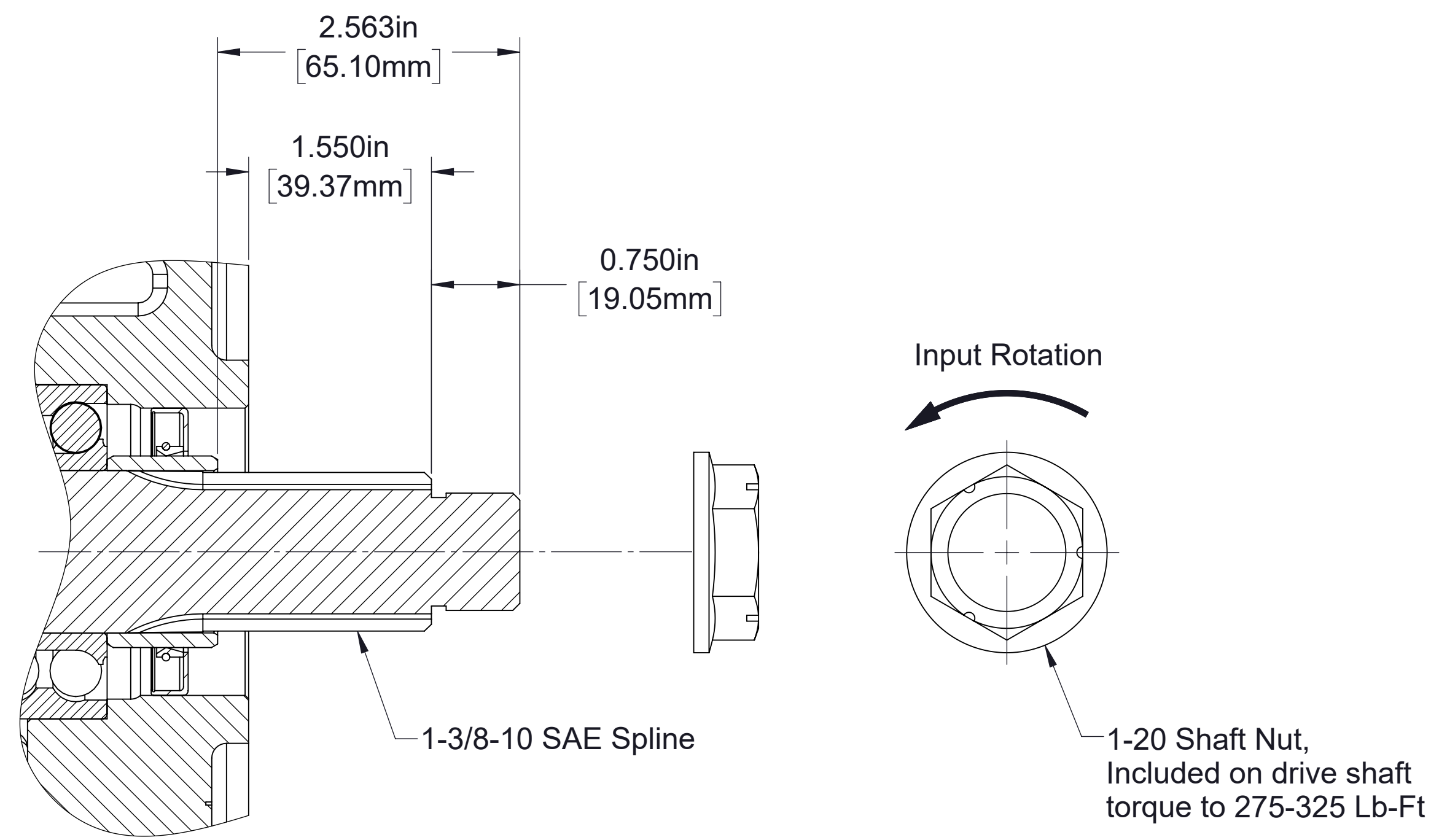

Input Shaft Detail

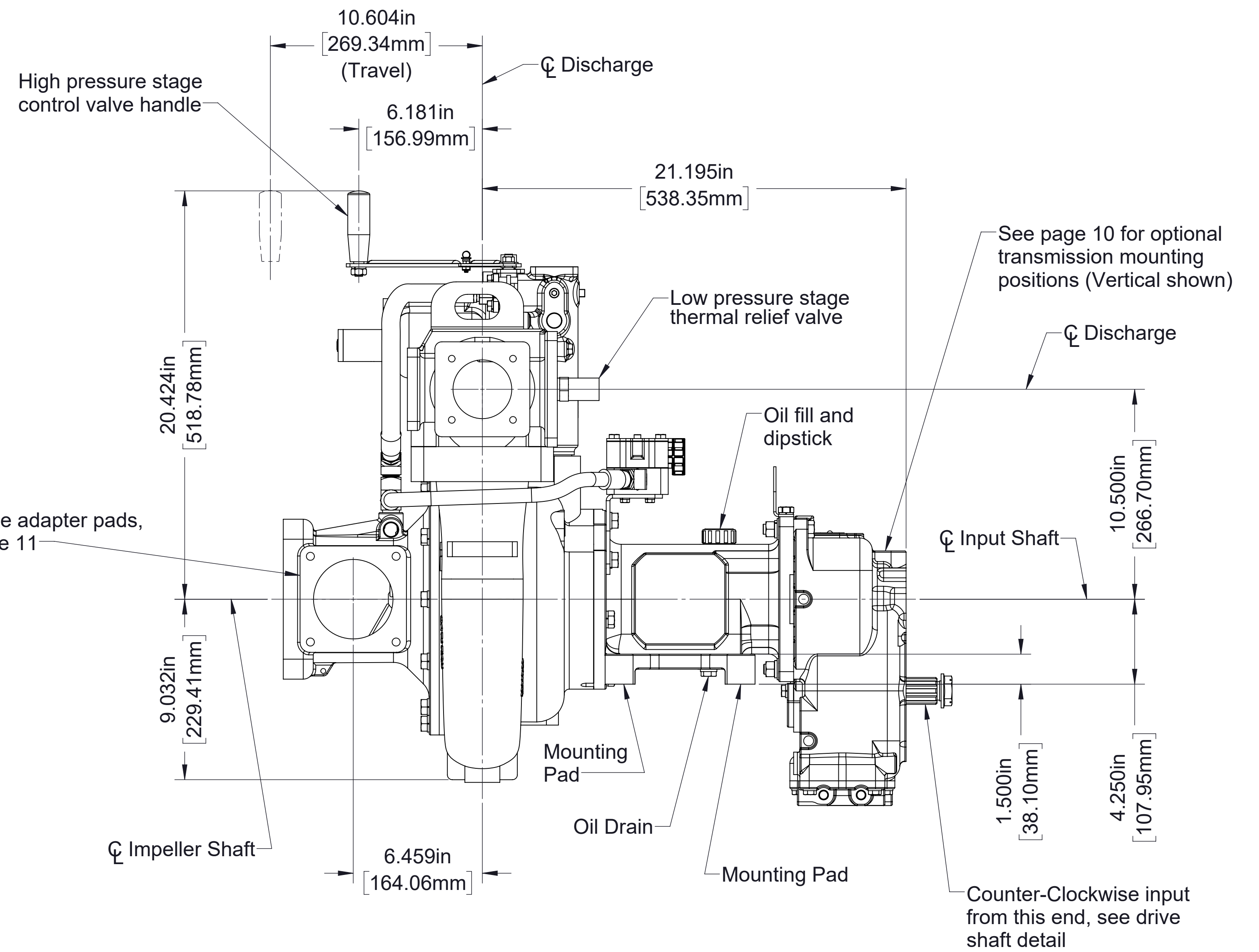
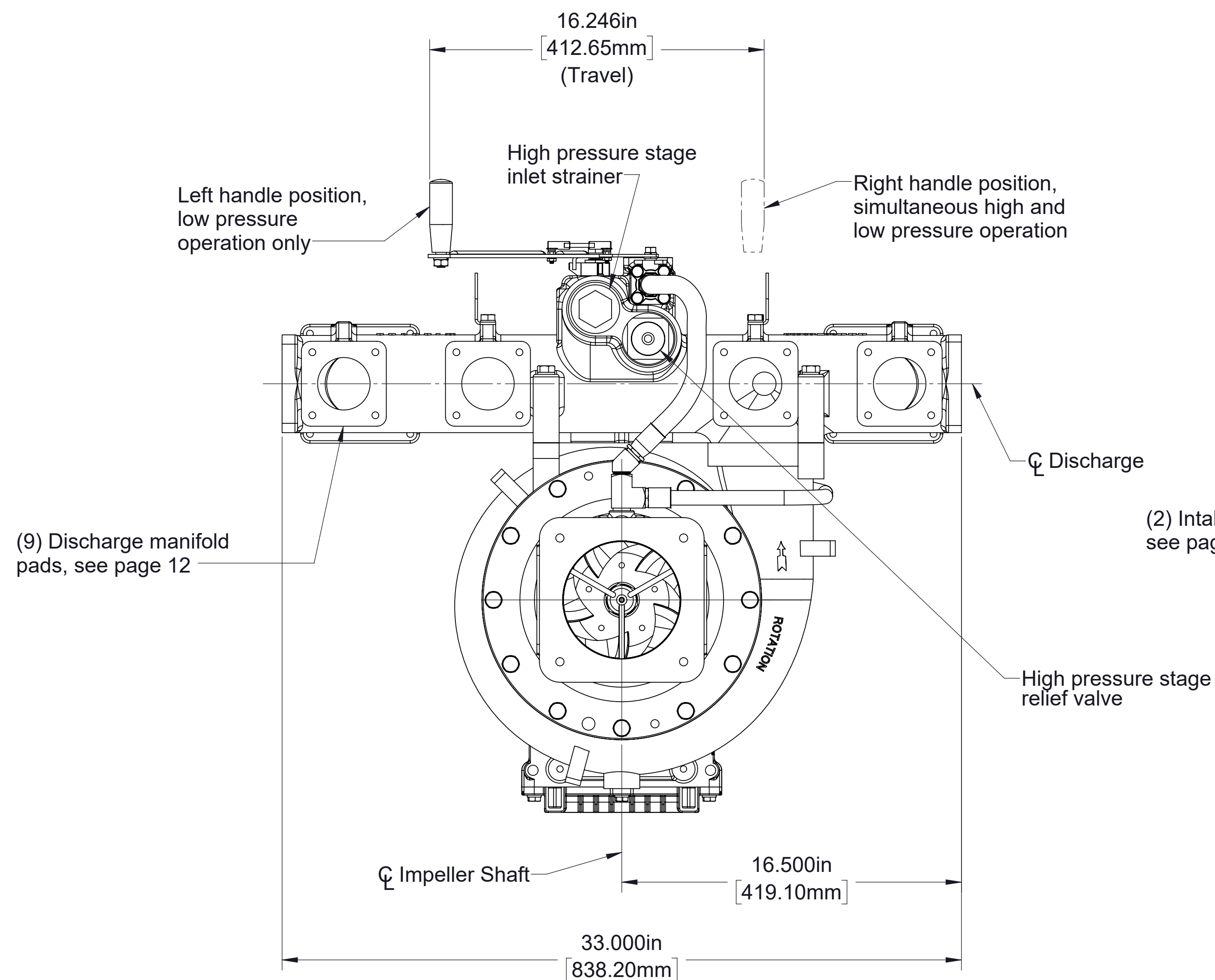
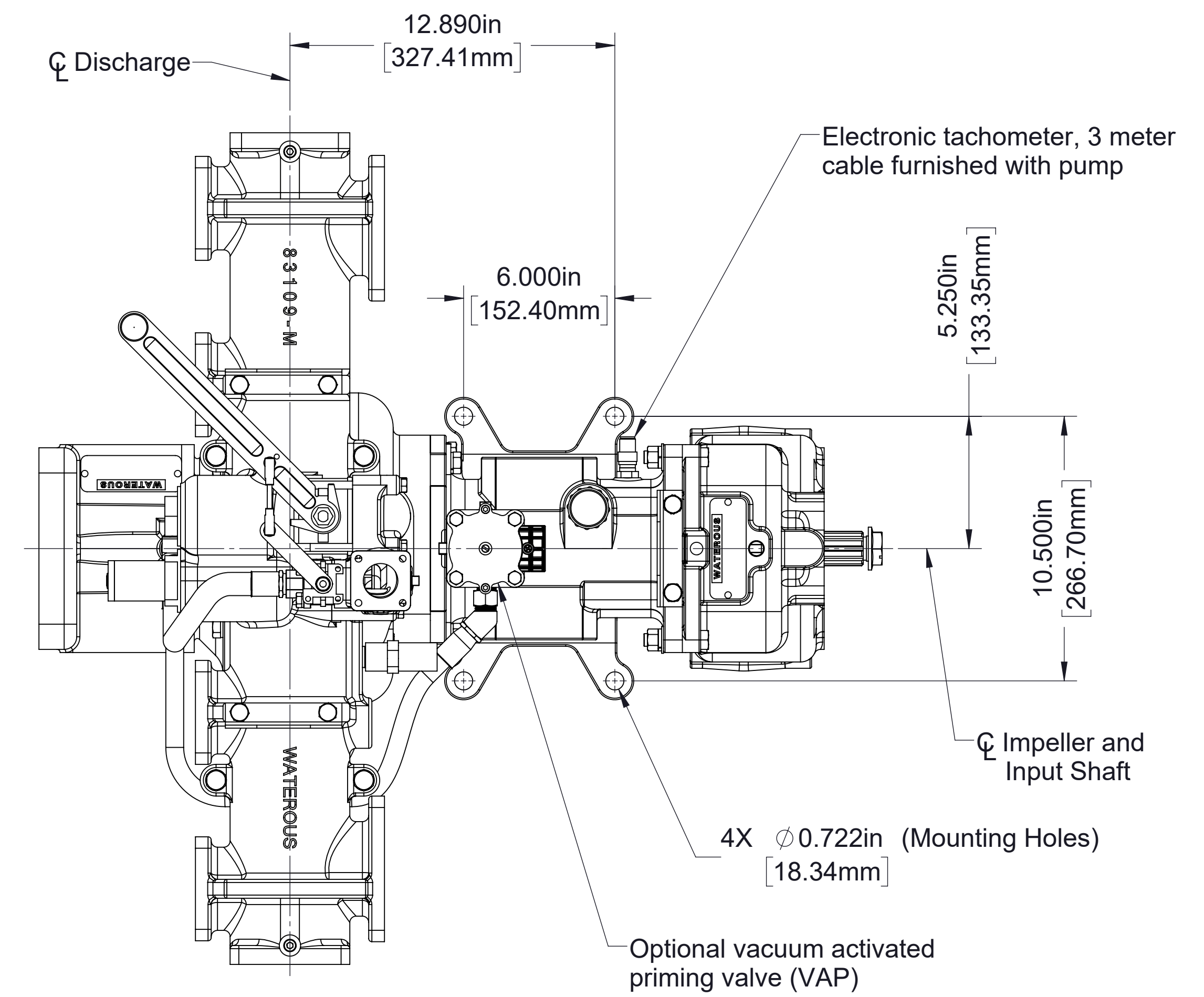

HLUK Pump with Manual Crossover Valve Actuator
Counter-Clockwise Input Rotation

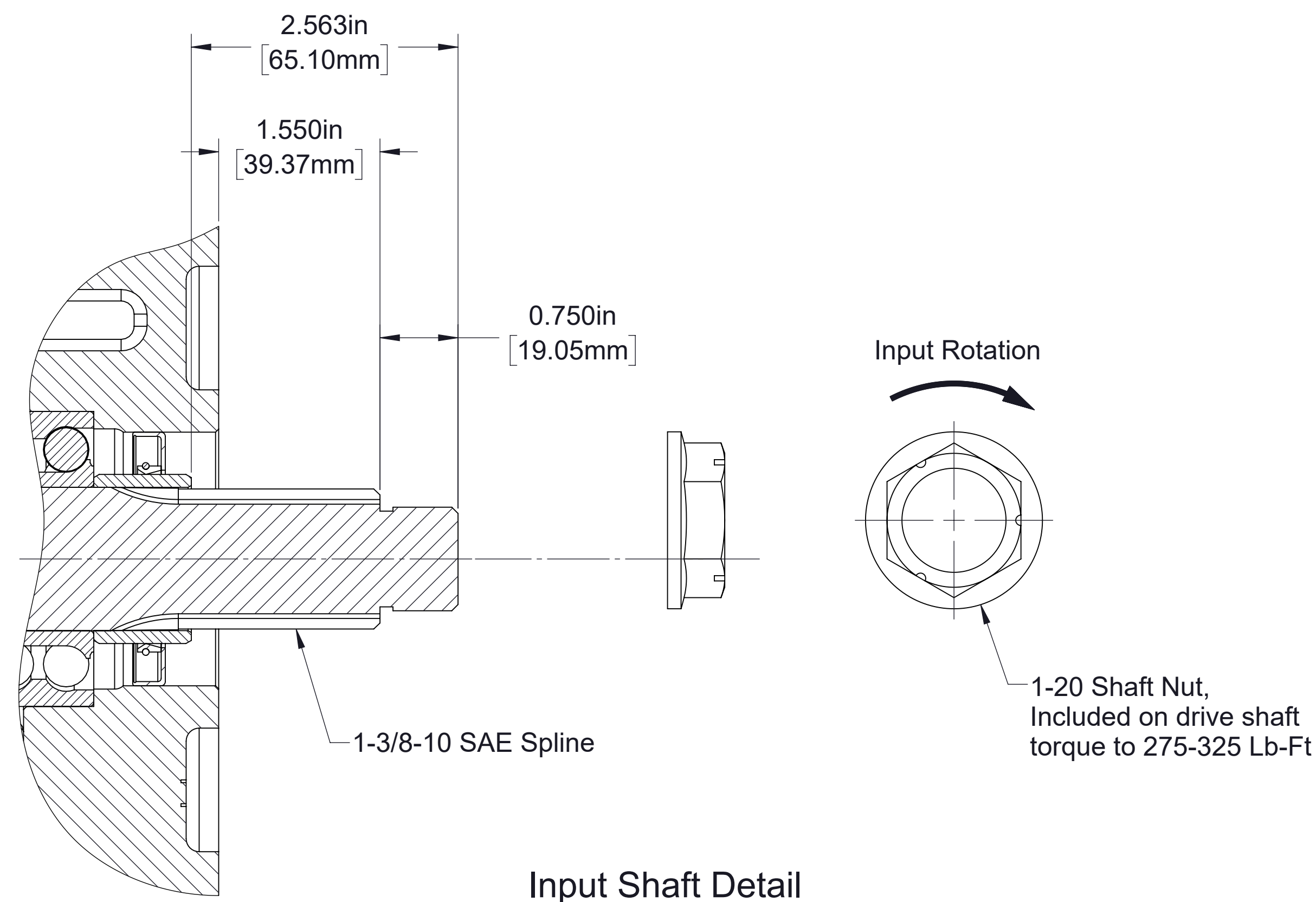

Input Shaft Detail

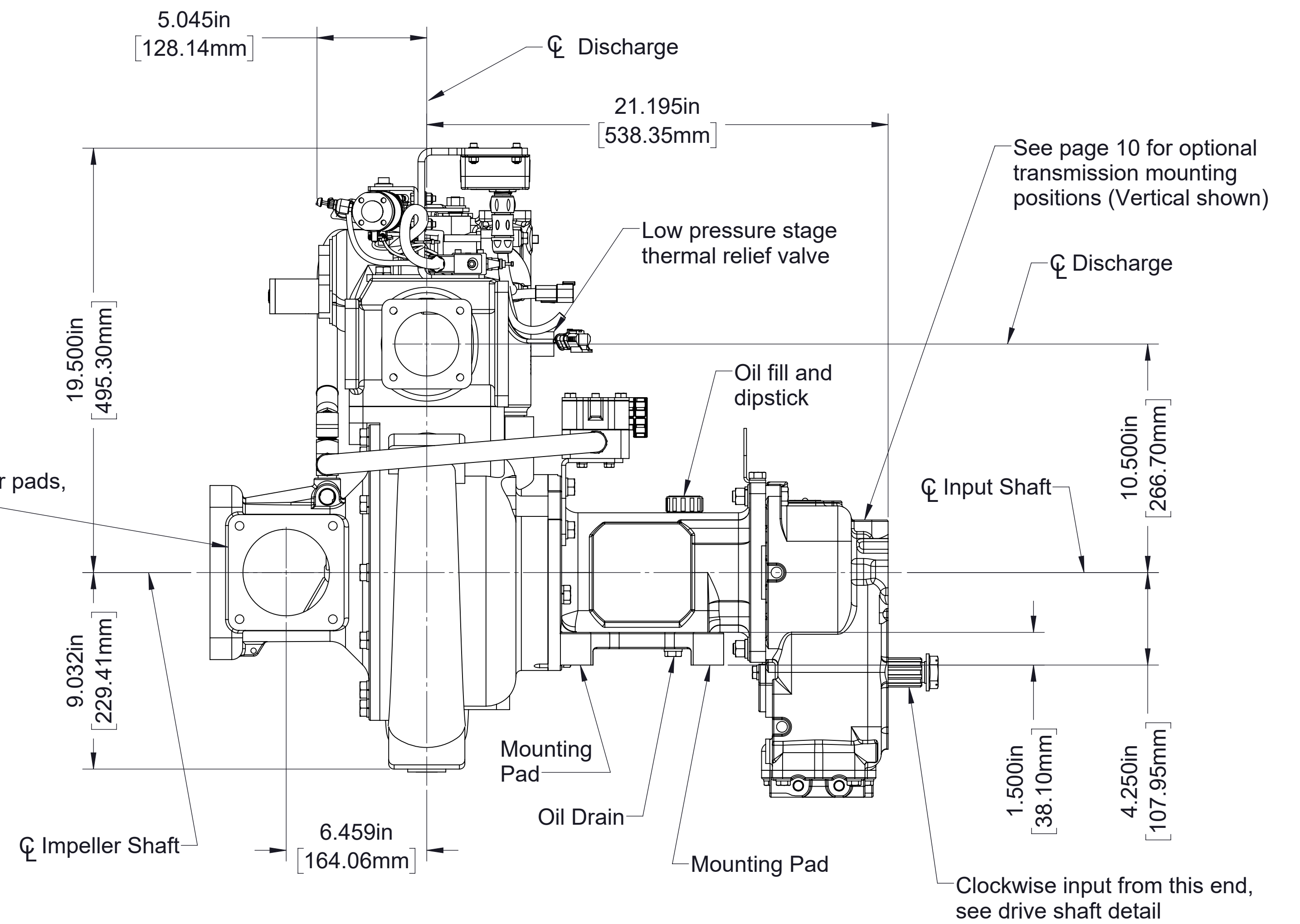
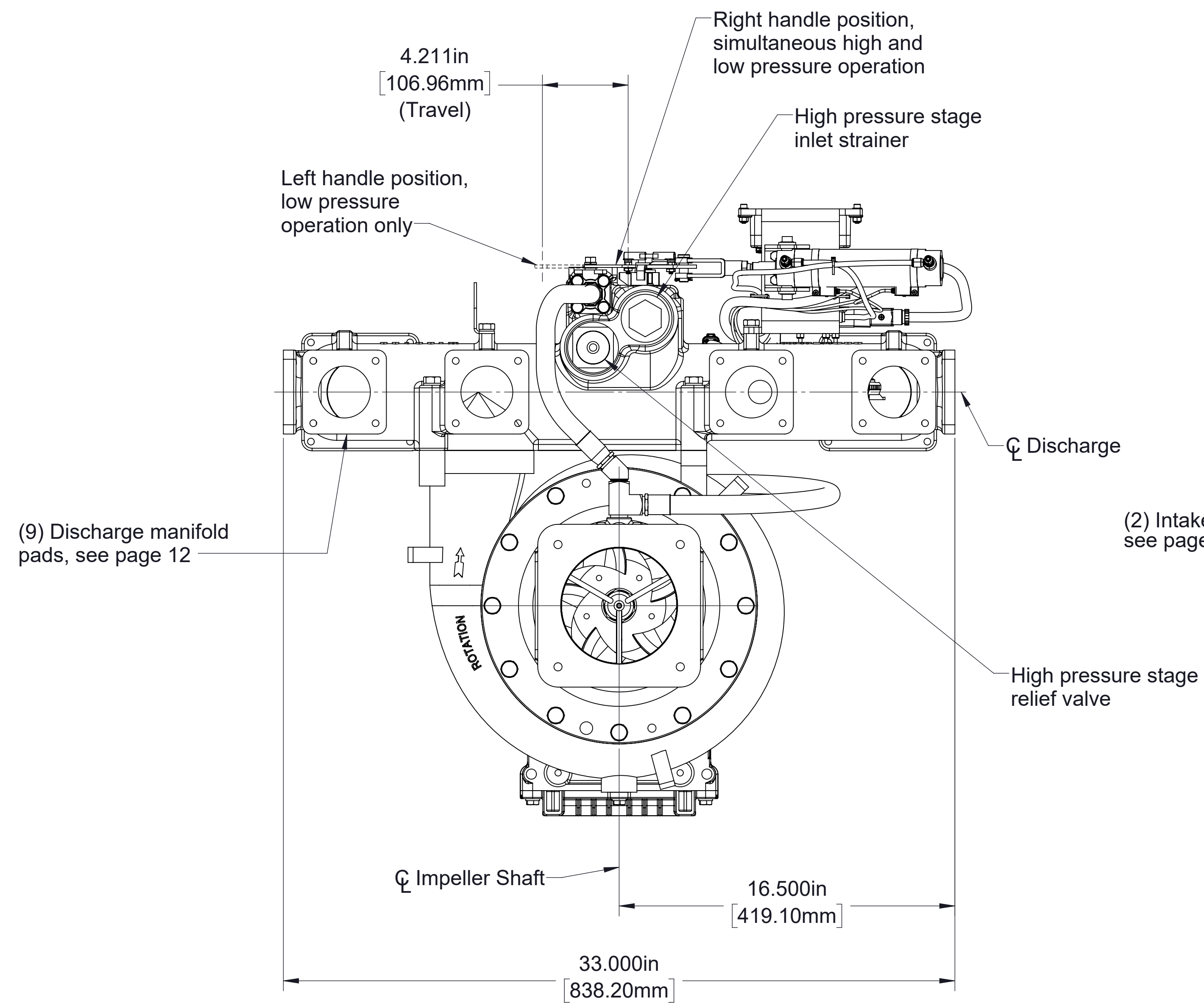
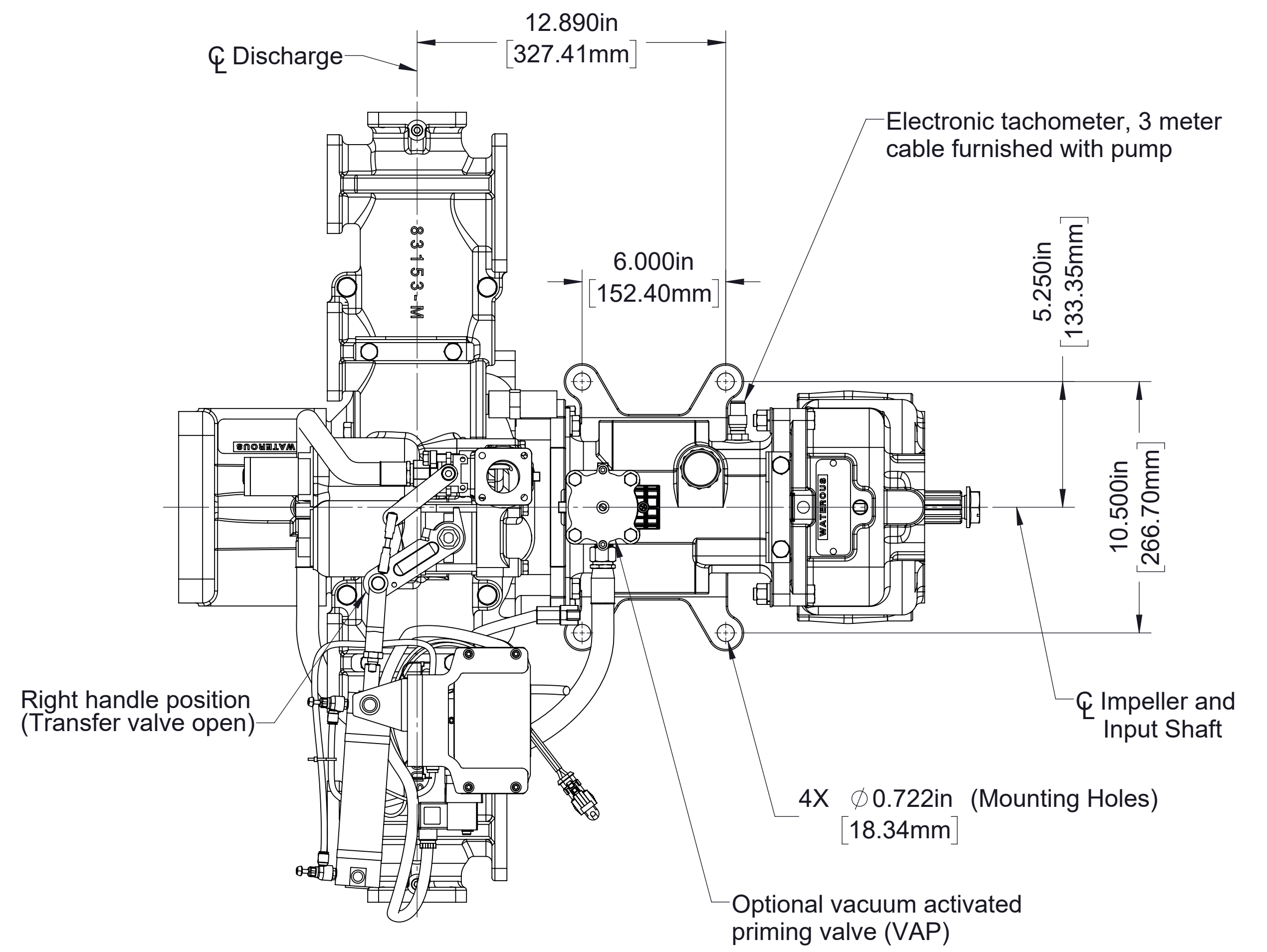

HLUK Pump with Pneumatic Crossover Valve Actuator
Clockwise Input Rotation

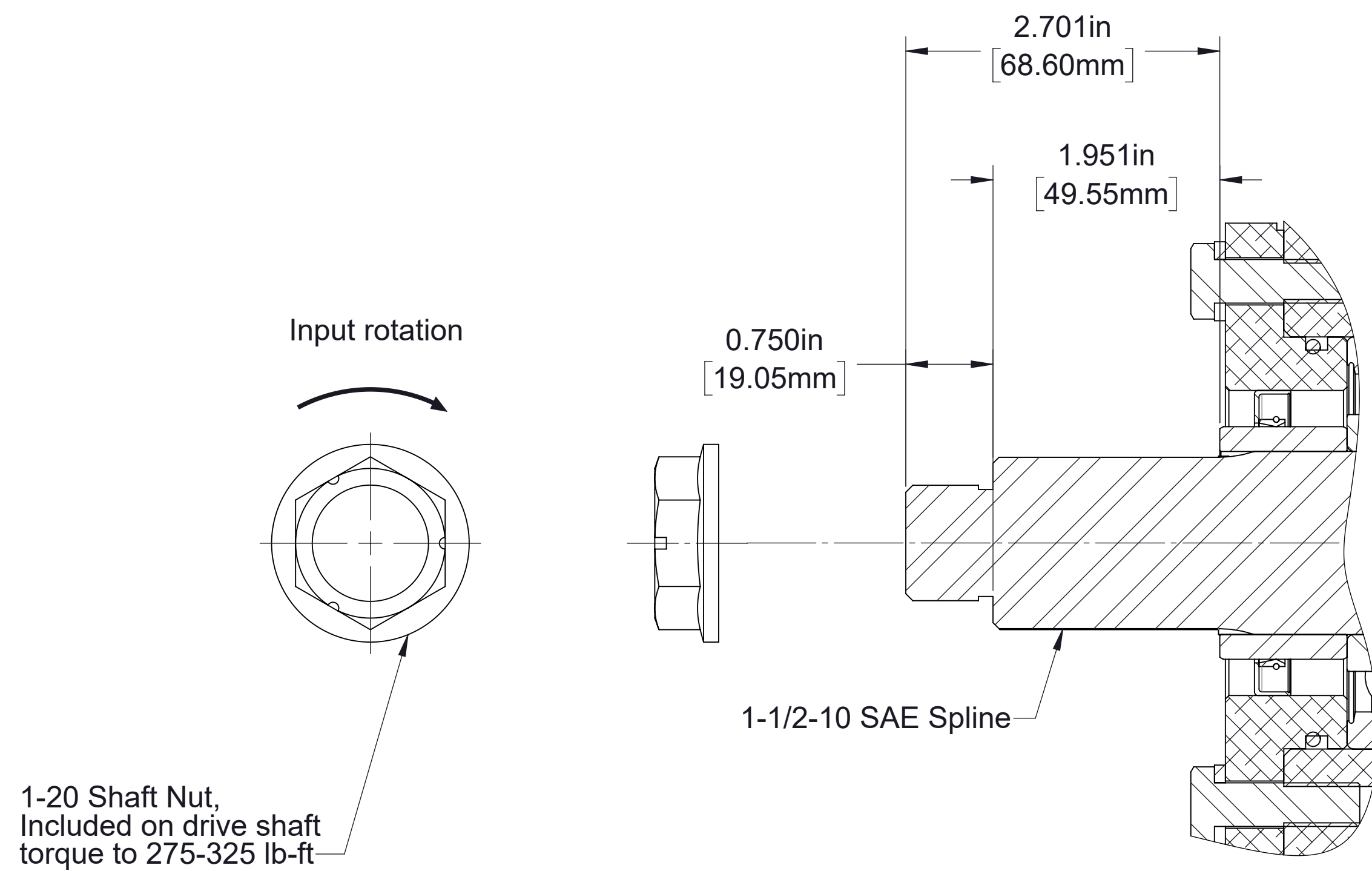

1-20 Shaft Nut,
Included on drive shaft
torque to 275-325 lb-ft

Input Shaft Detail

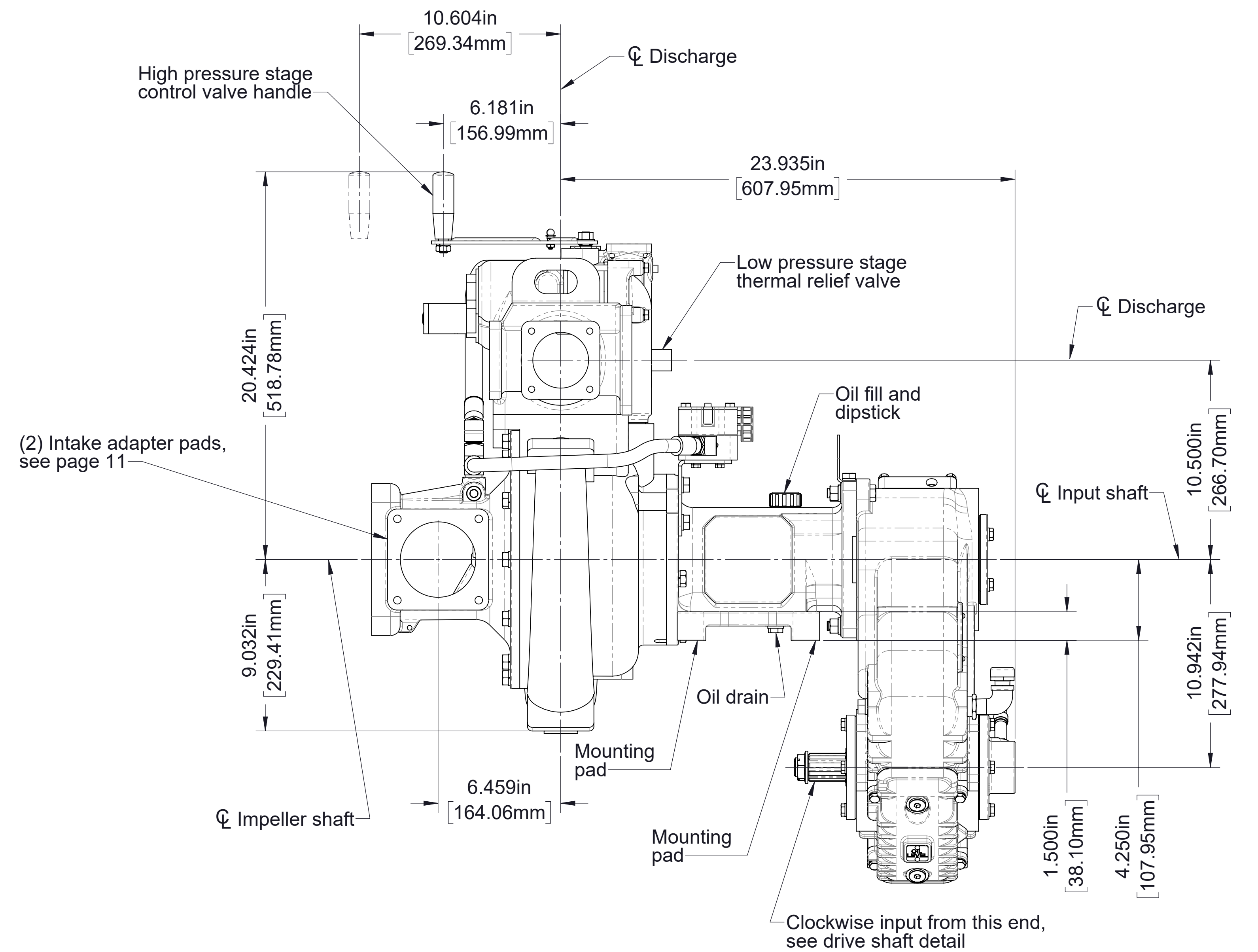
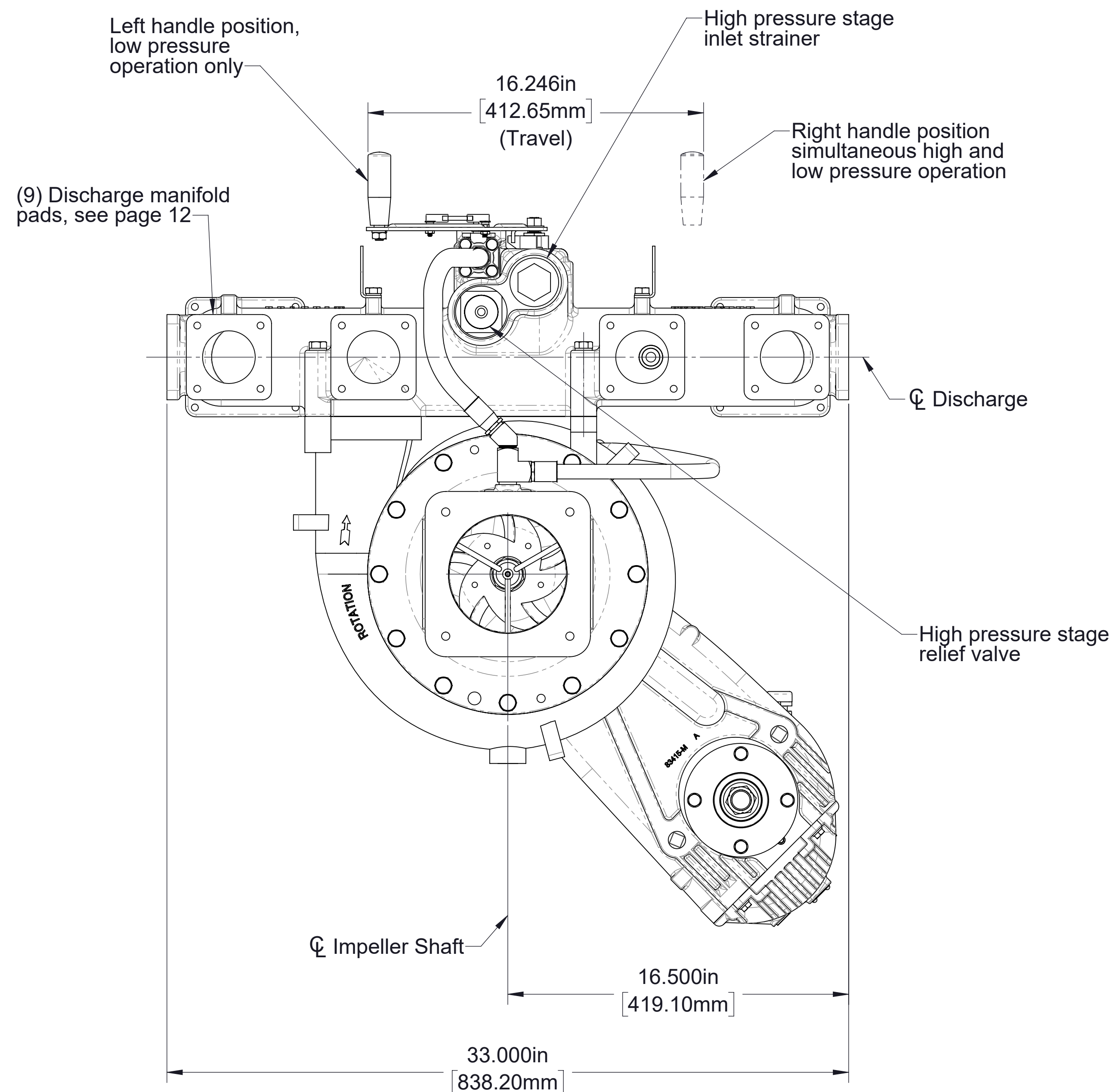
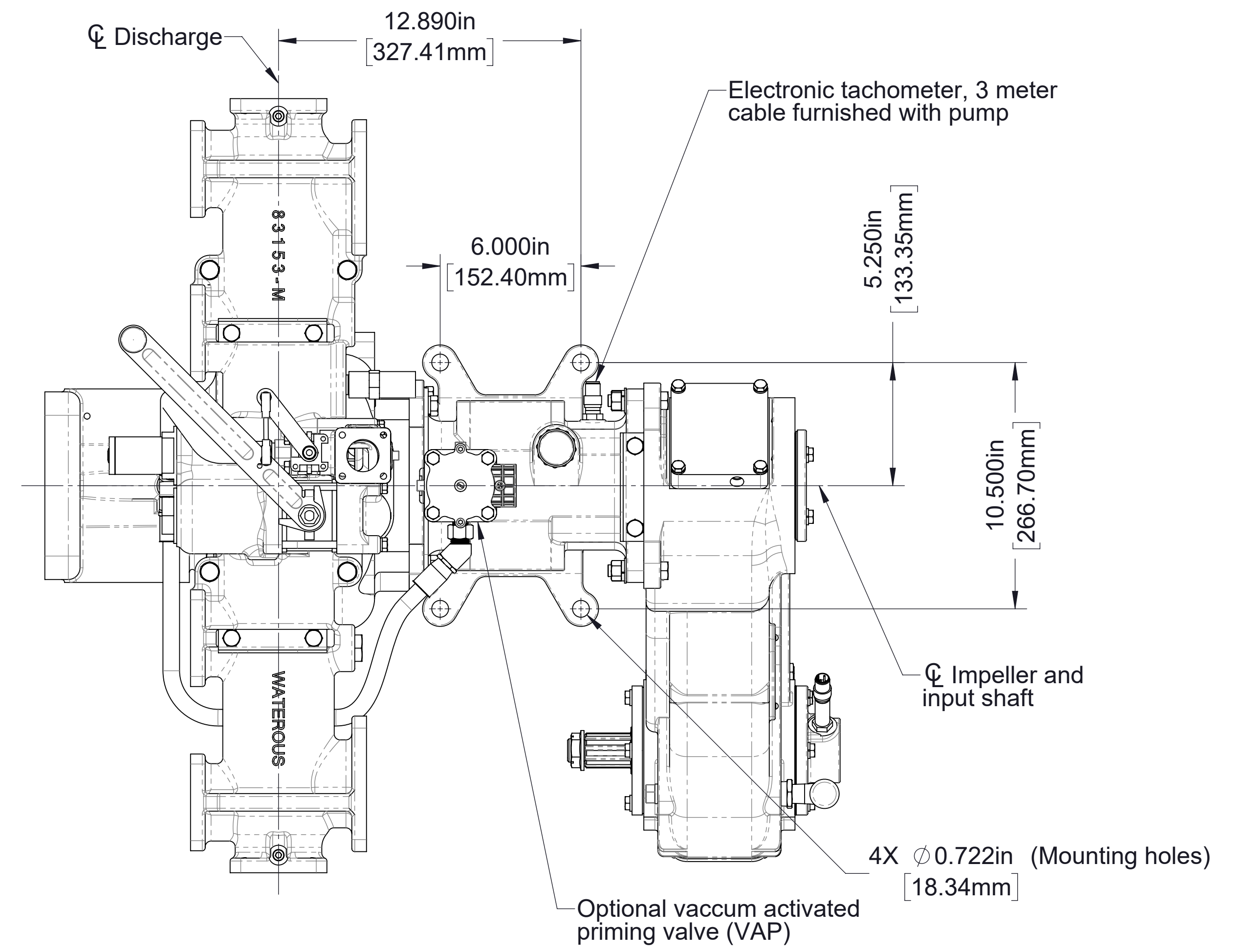

**HLUPA Pump with Manual Crossover Valve Actuator
Clockwise Input Rotation**

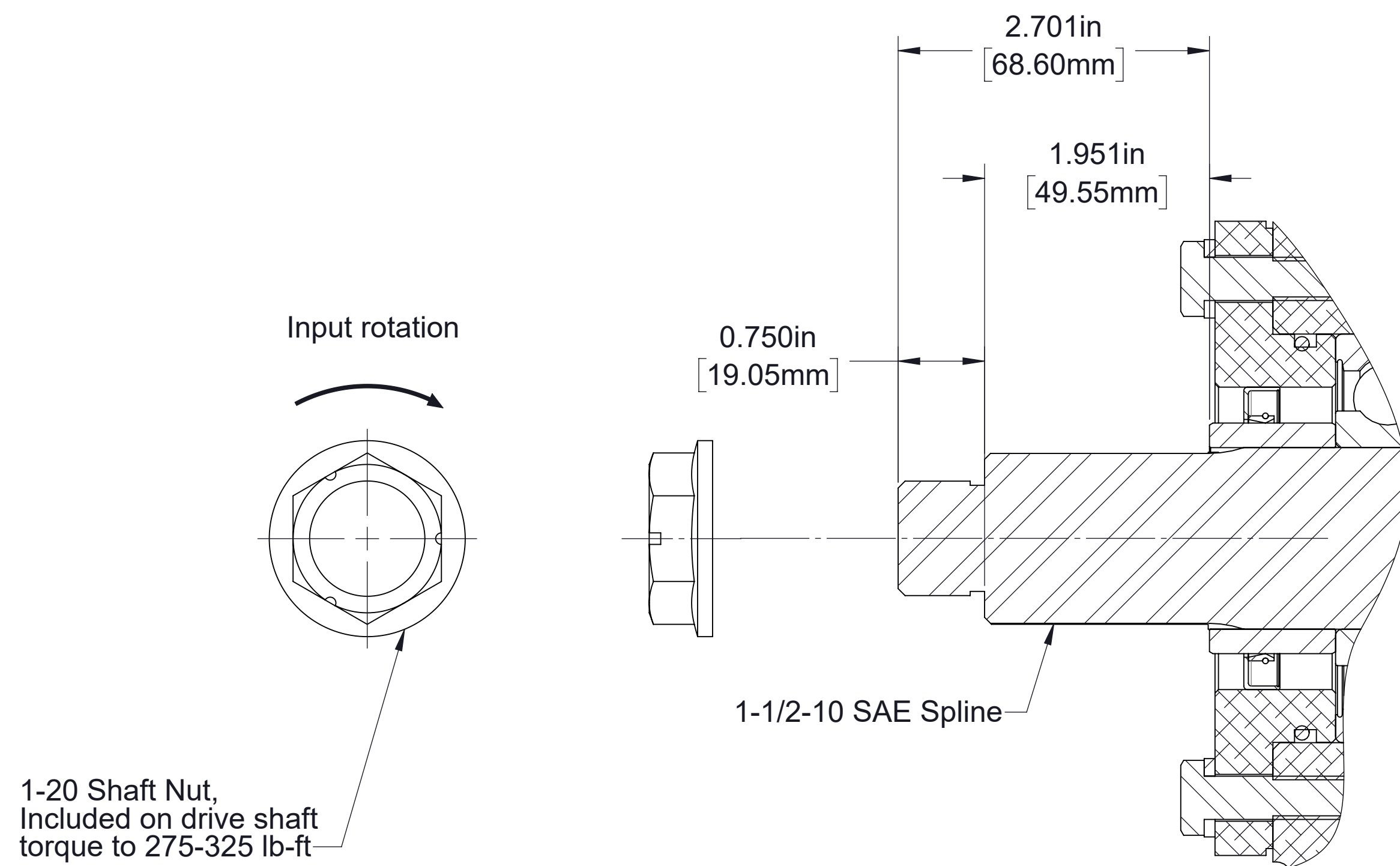

Input Shaft Detail

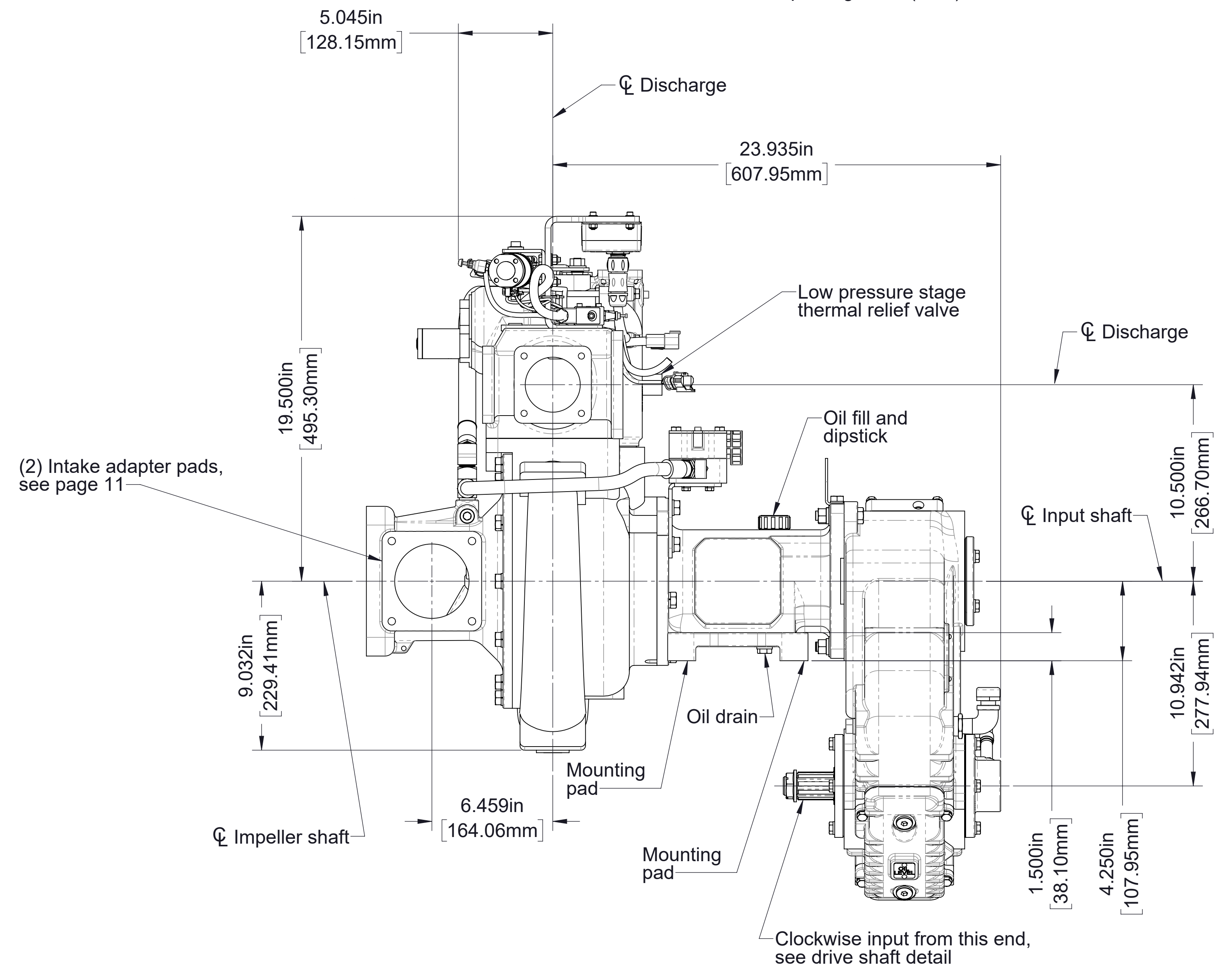
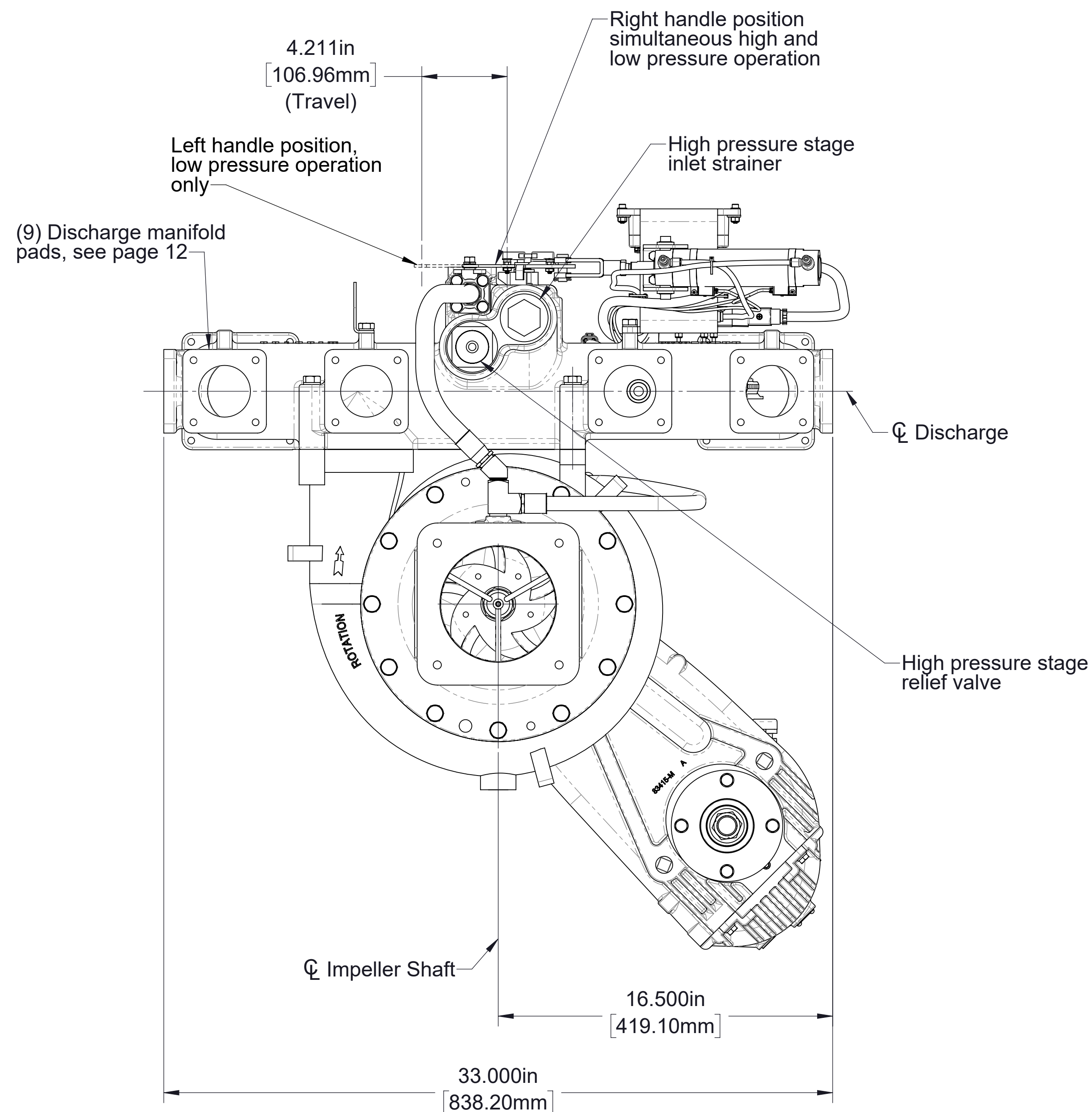
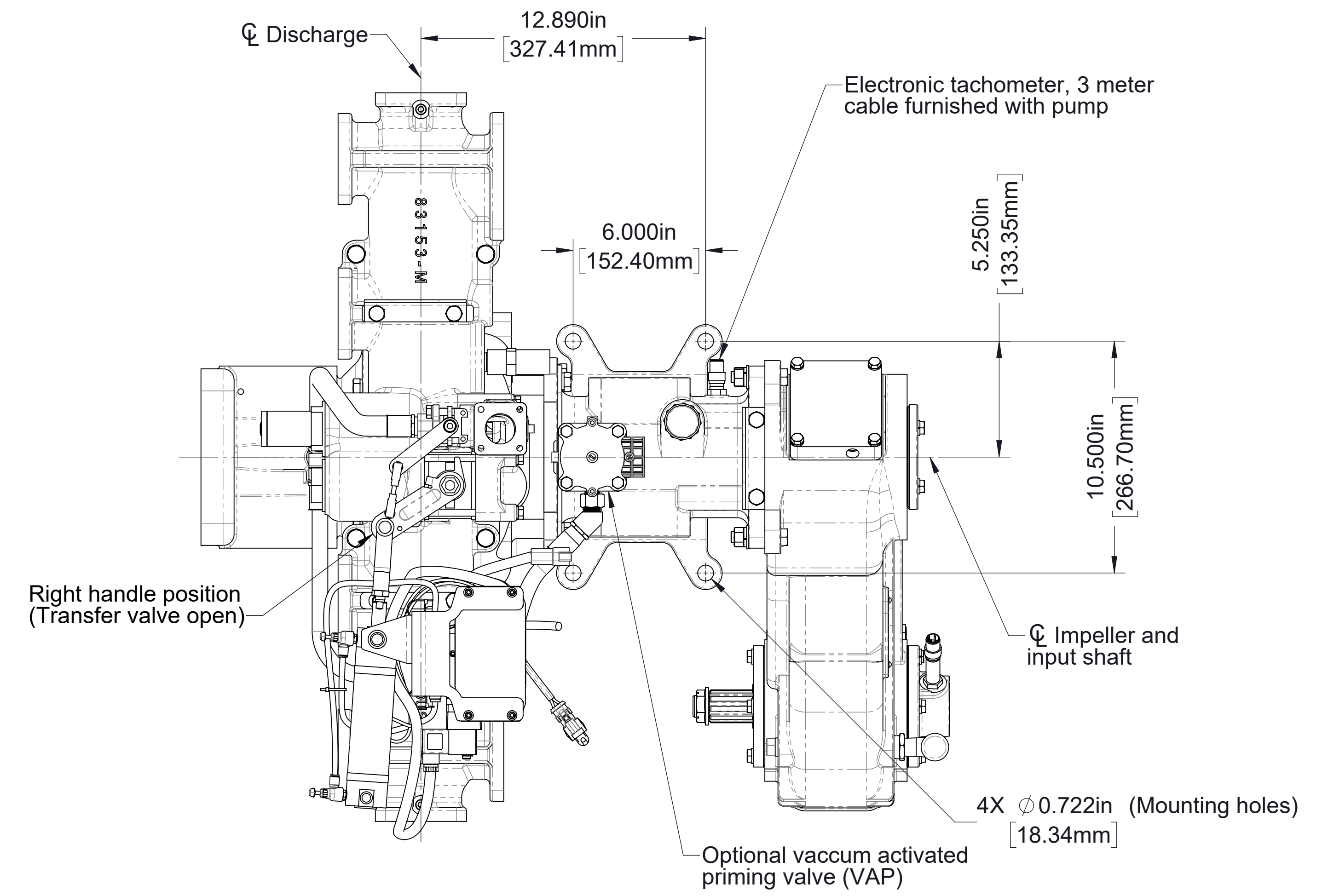

**HLUPA Pump with Pneumatic Crossover Valve Actuator
Clockwise Input Rotation**

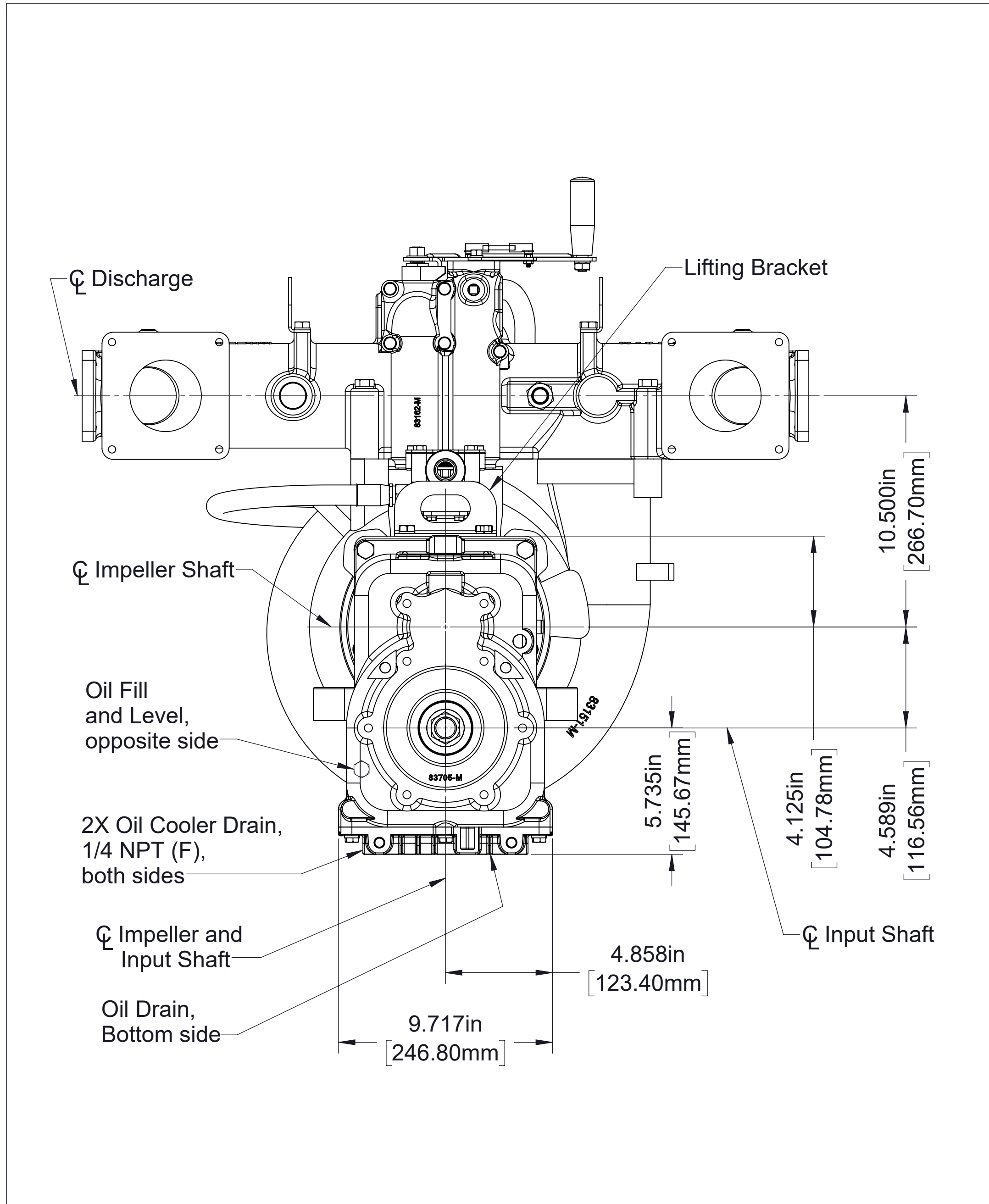

Vertical

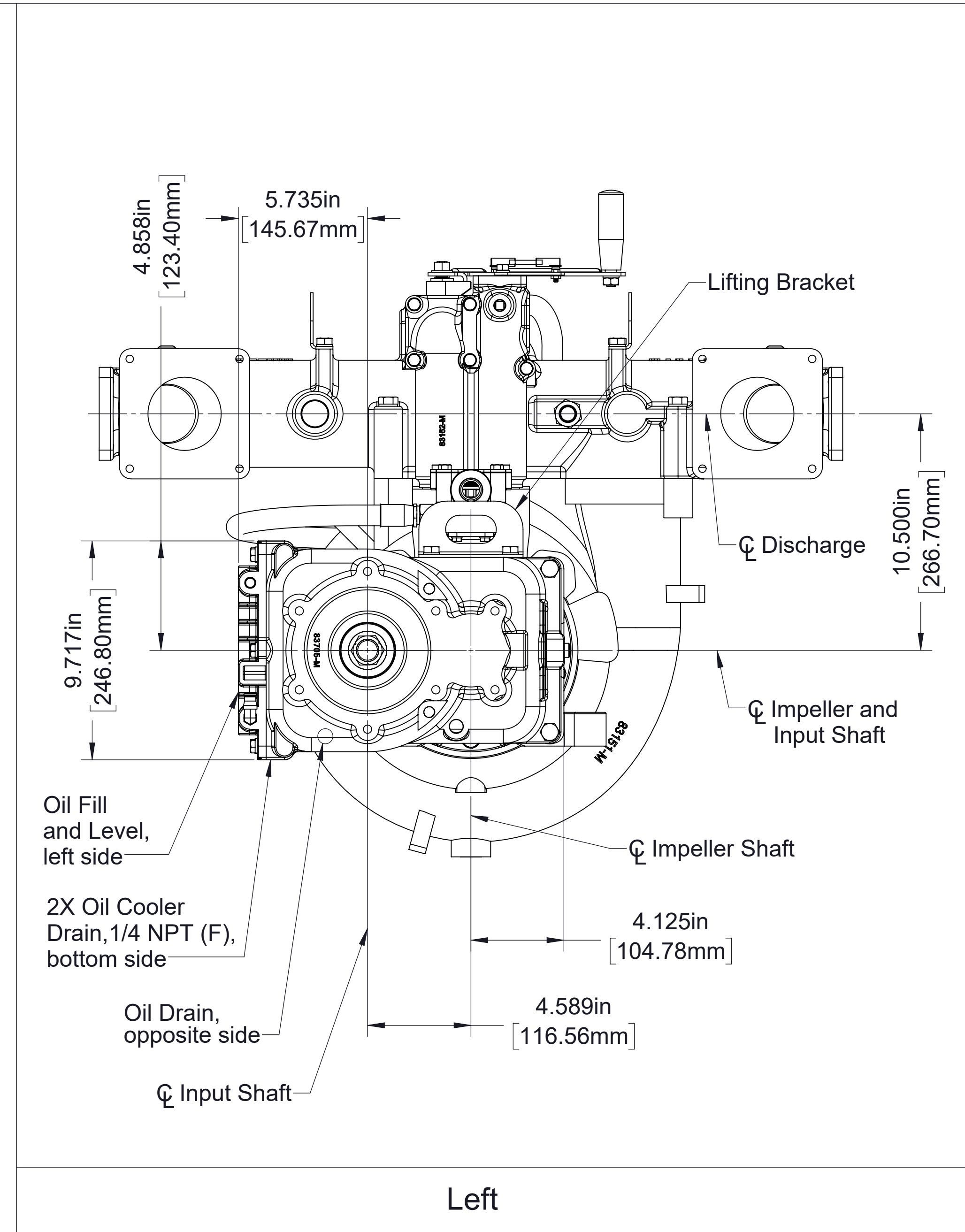

Left

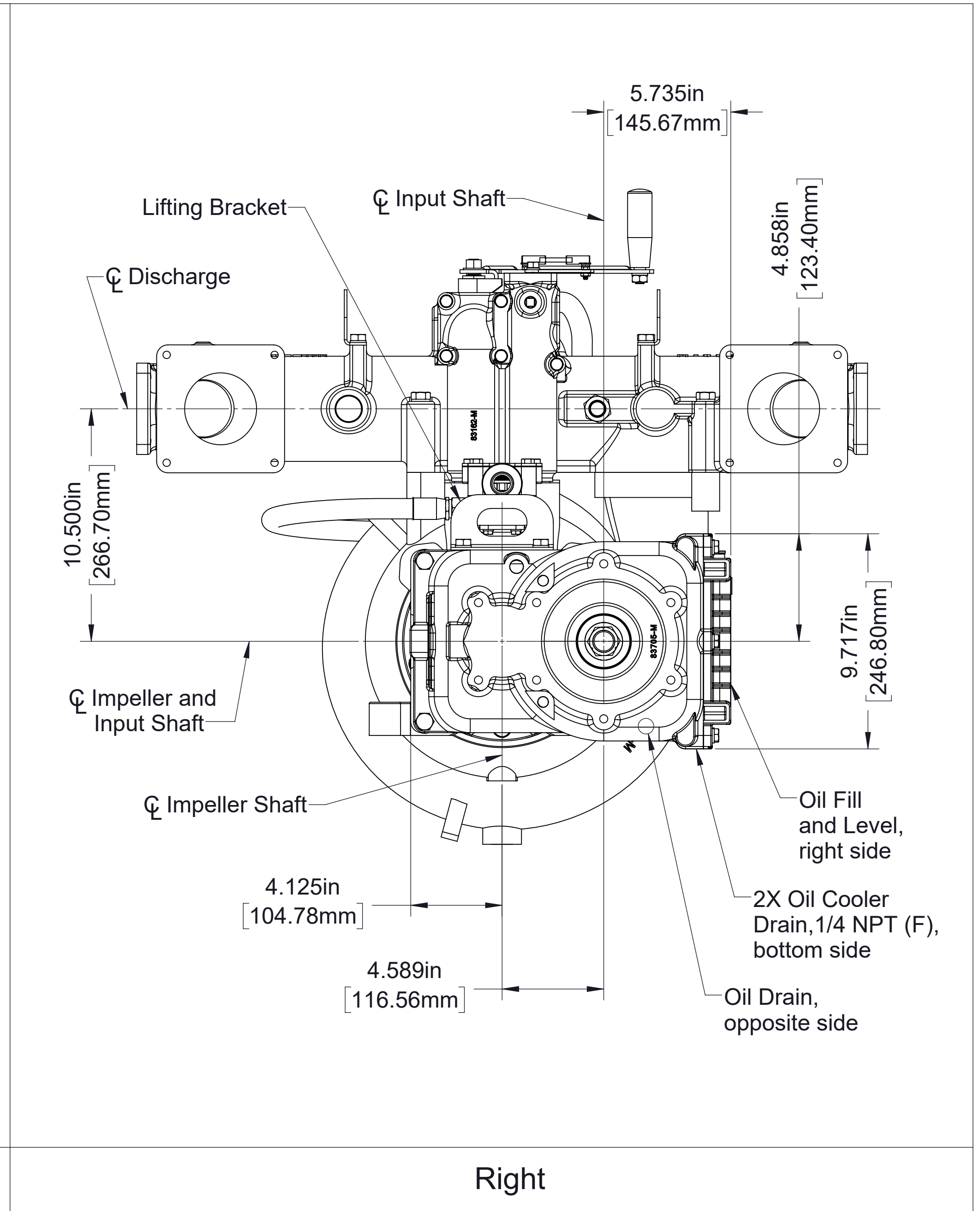

Right

Horizontal

**HLUK Pump
Transmission Mounting Positions**
 (Defined as viewed from drive end of pump)

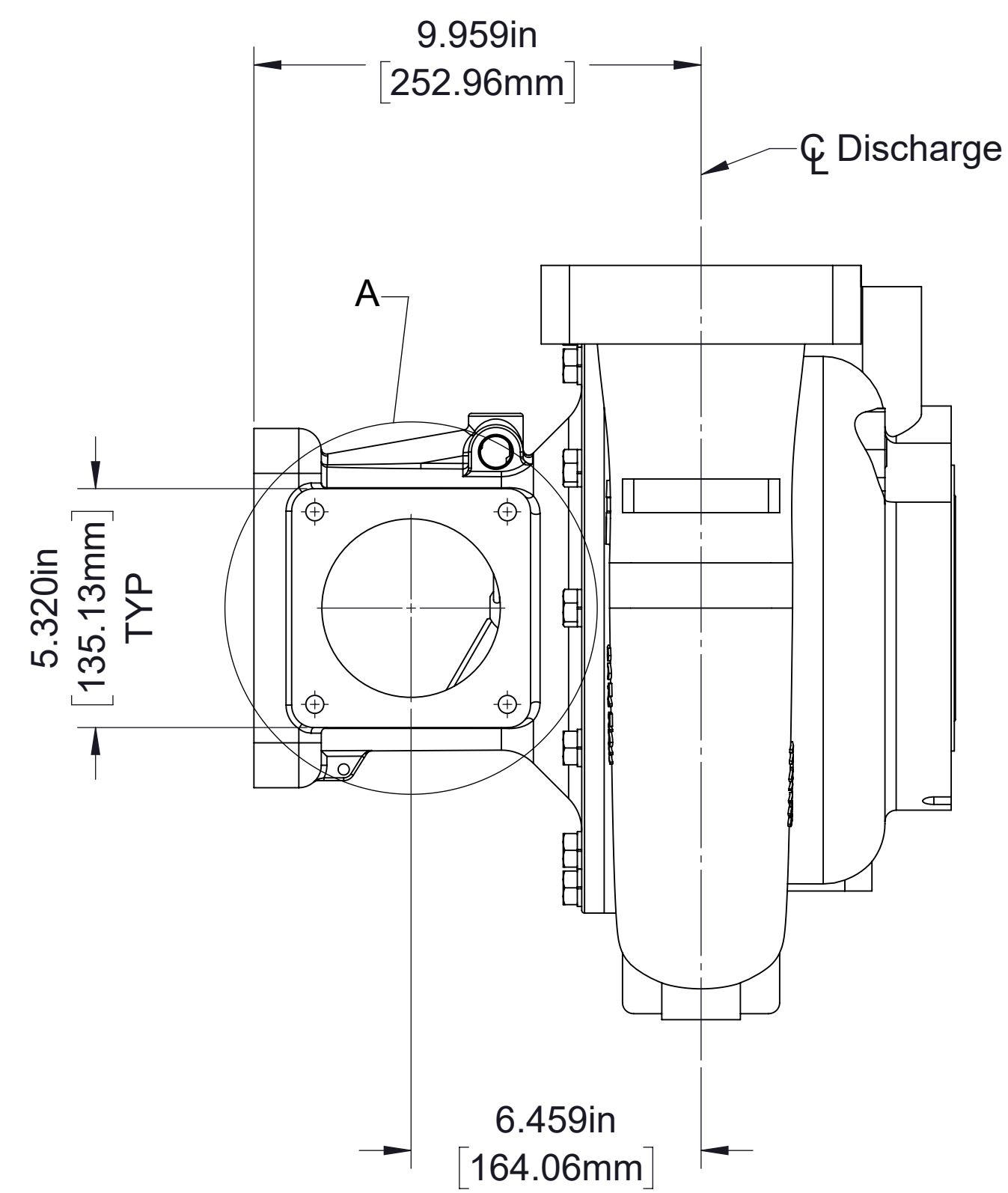
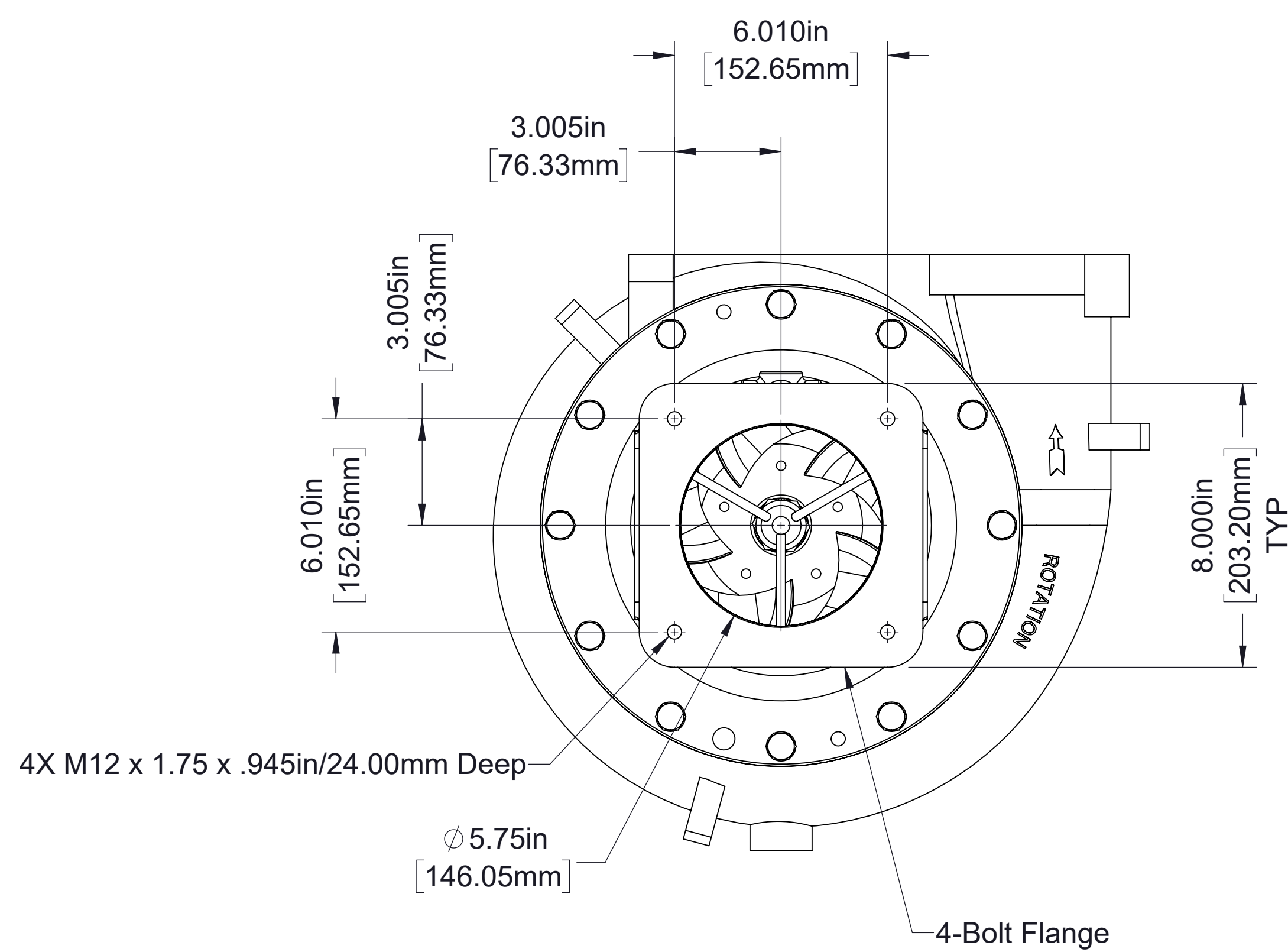
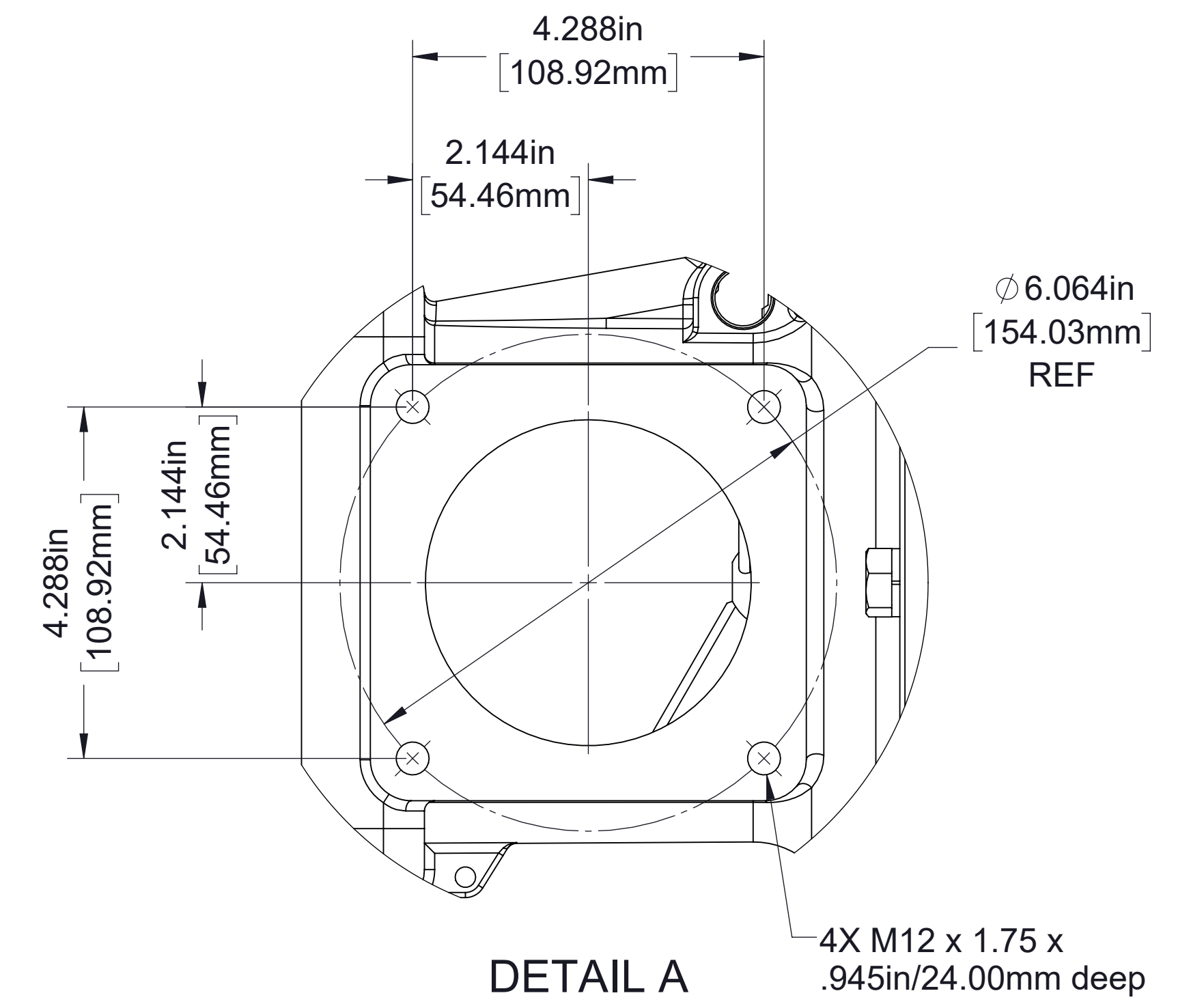
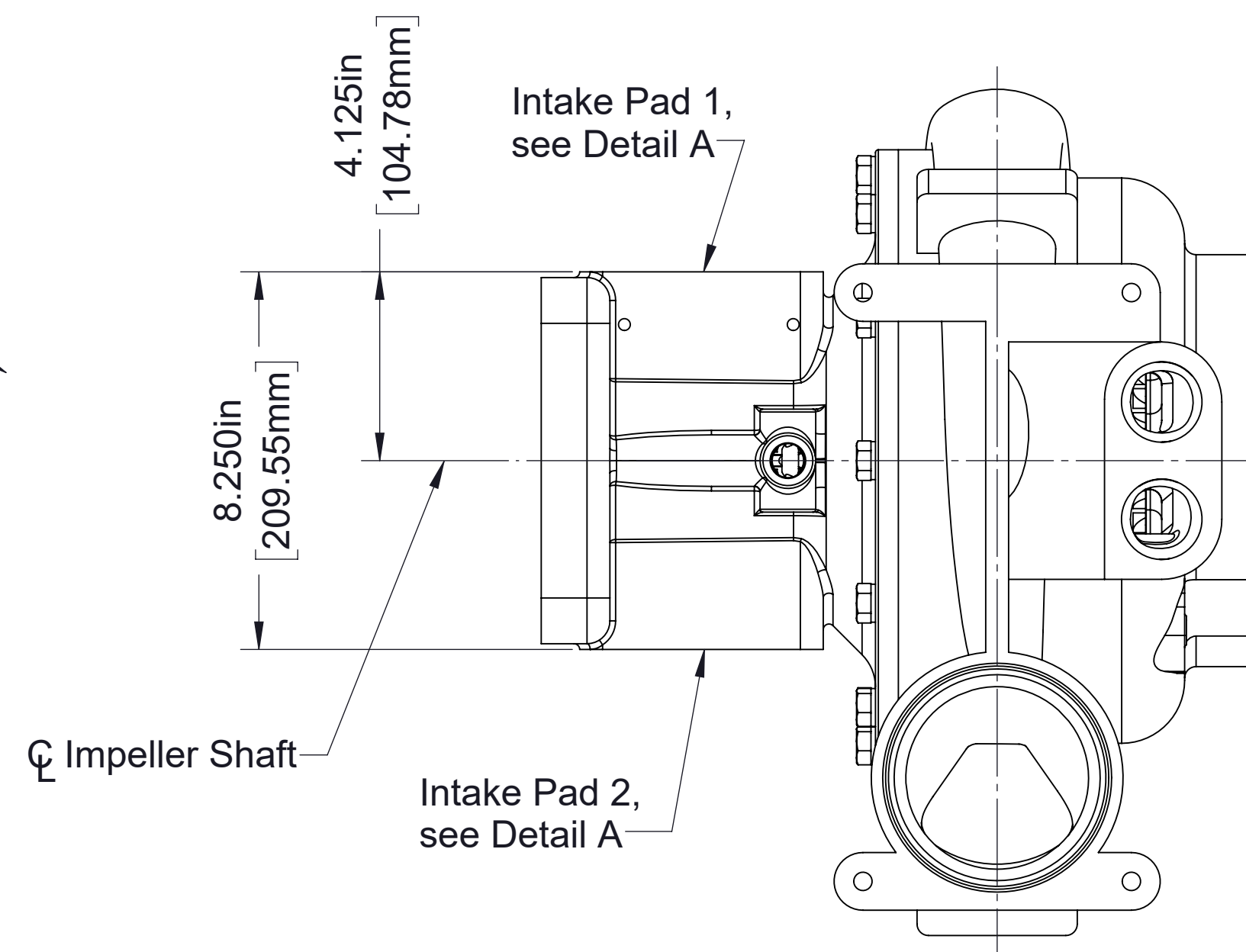
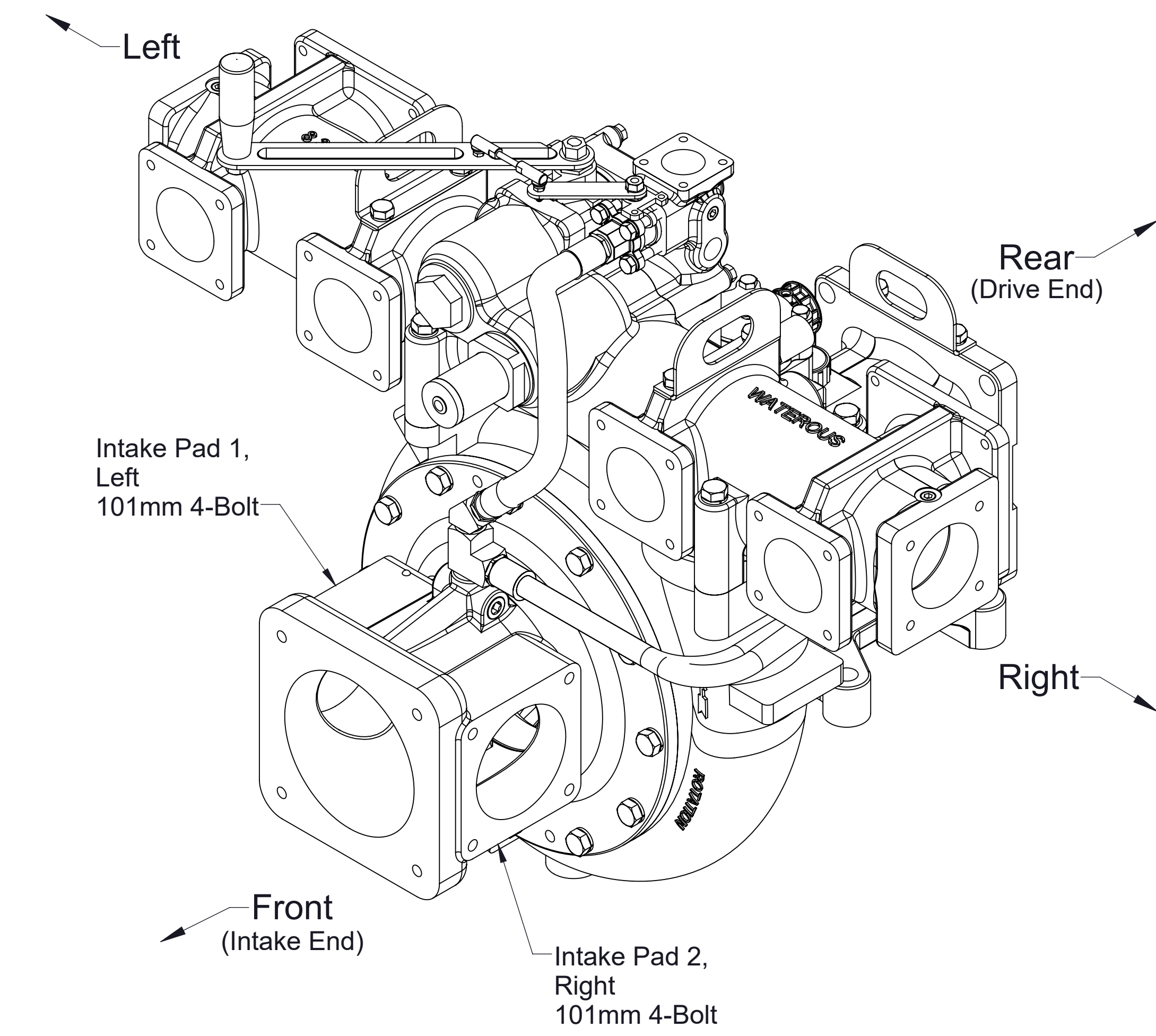

DETAIL A
 101 mm 4-Bolt
 See page 9 for auxiliary fittings
 which may be mounted on this pad

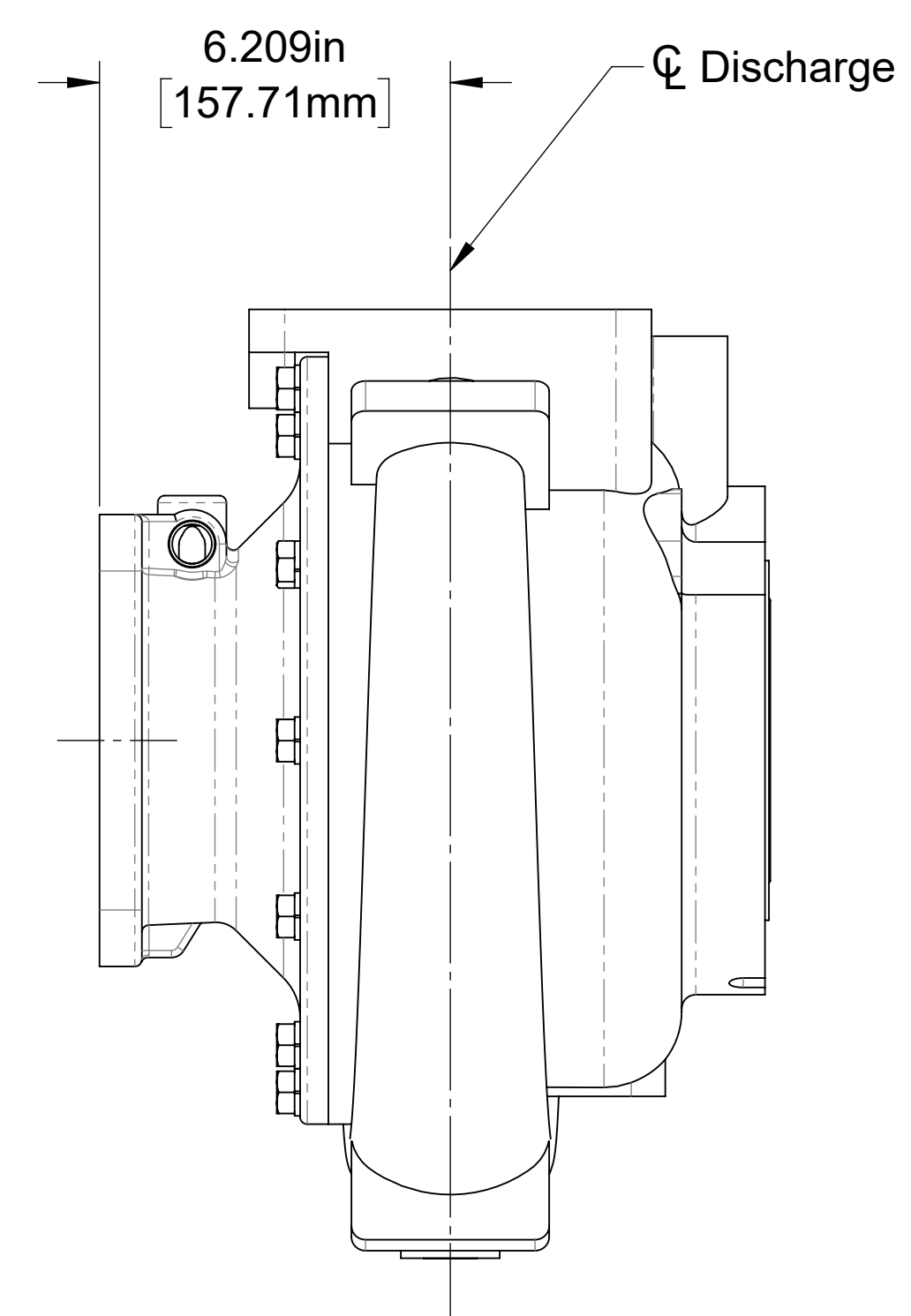
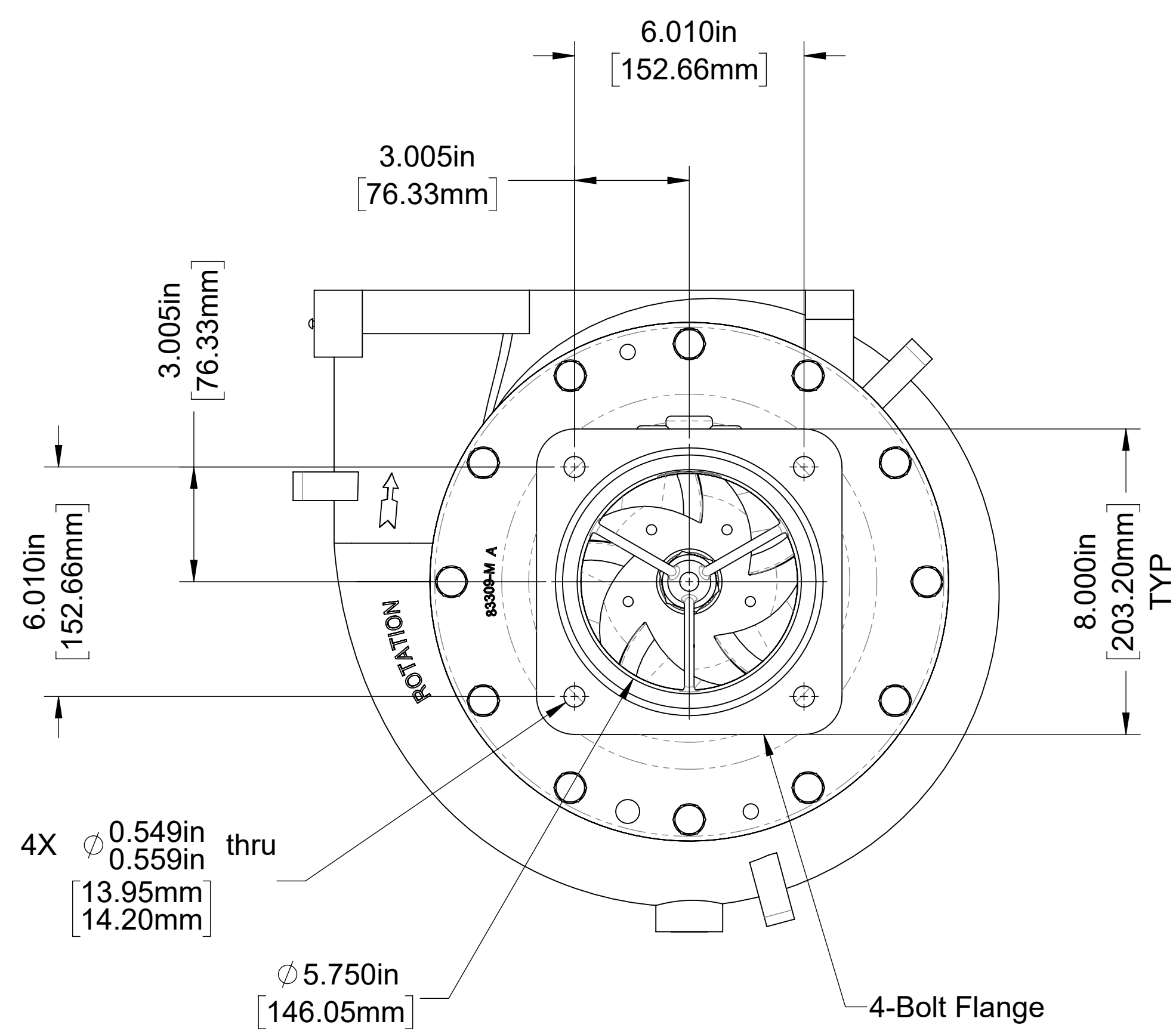
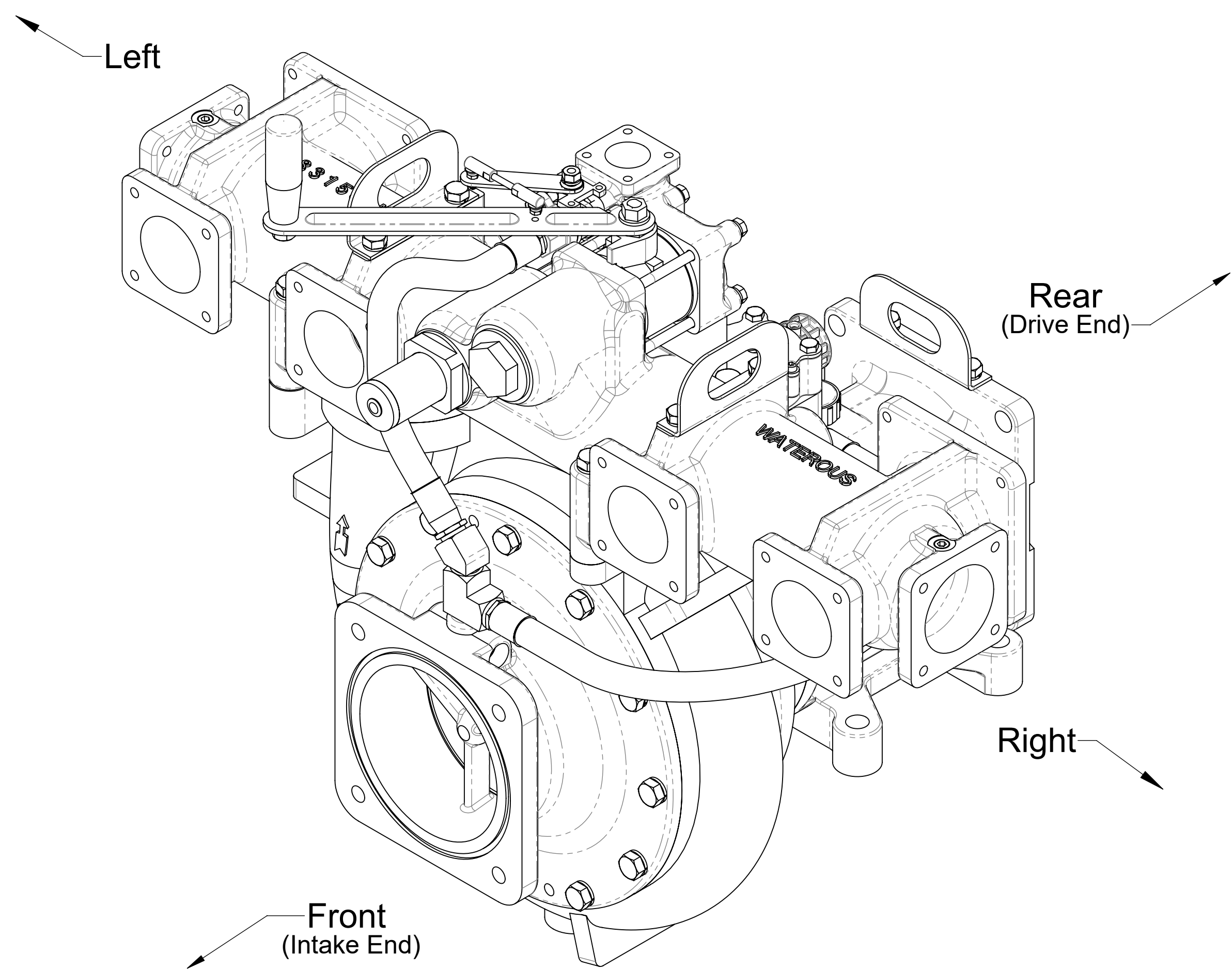

Short Intake Connection

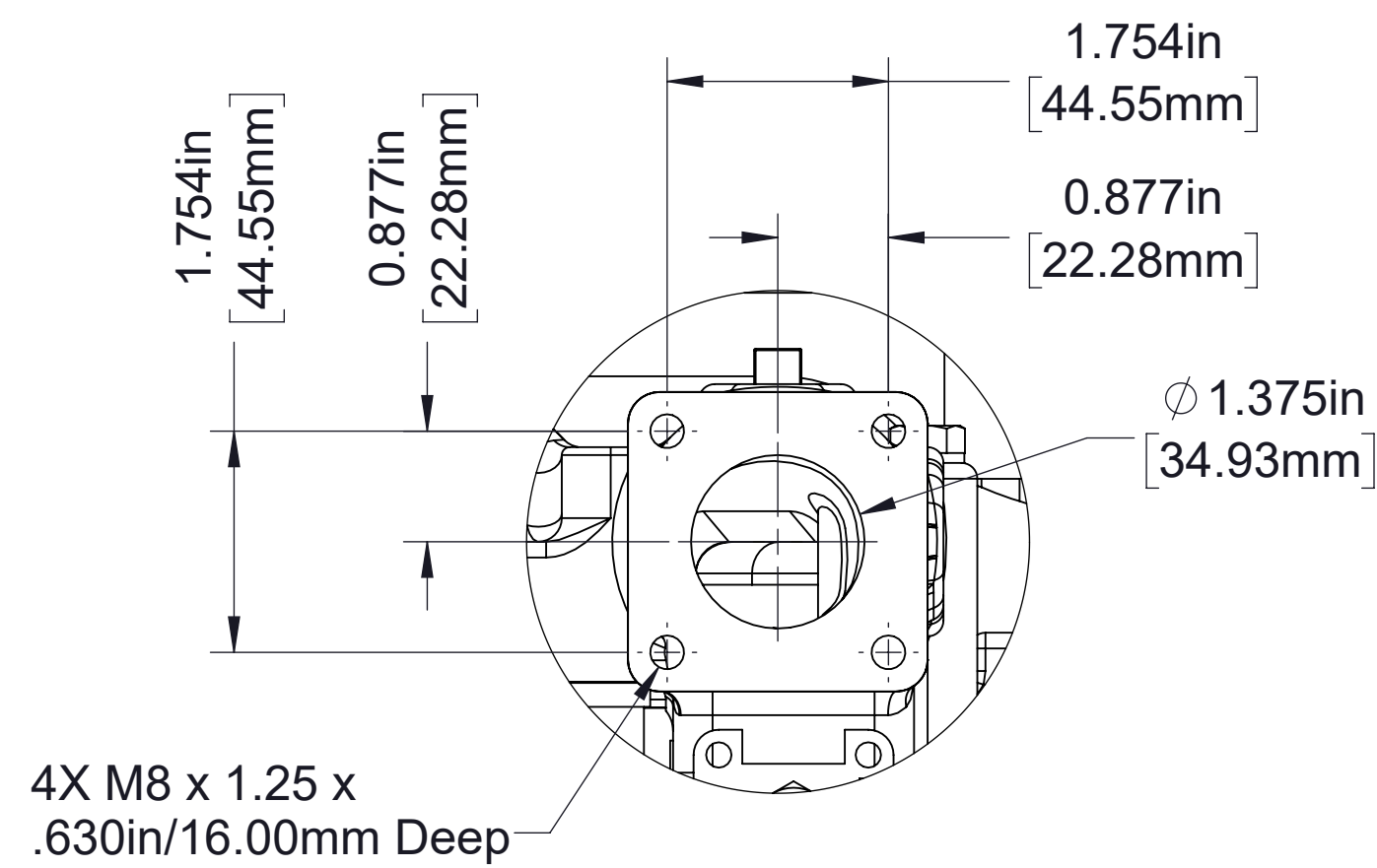

Detail B

35 mm 4-Bolt
See page 9 for auxiliary fittings
which may be mounted on this pad

4X M8 x 1.25 x
.630in/16.00mm Deep

Pad	Opening Diameter
1	2.940in/74.68mm
2	
3	
4	2.550in/64.77mm
8	
9	

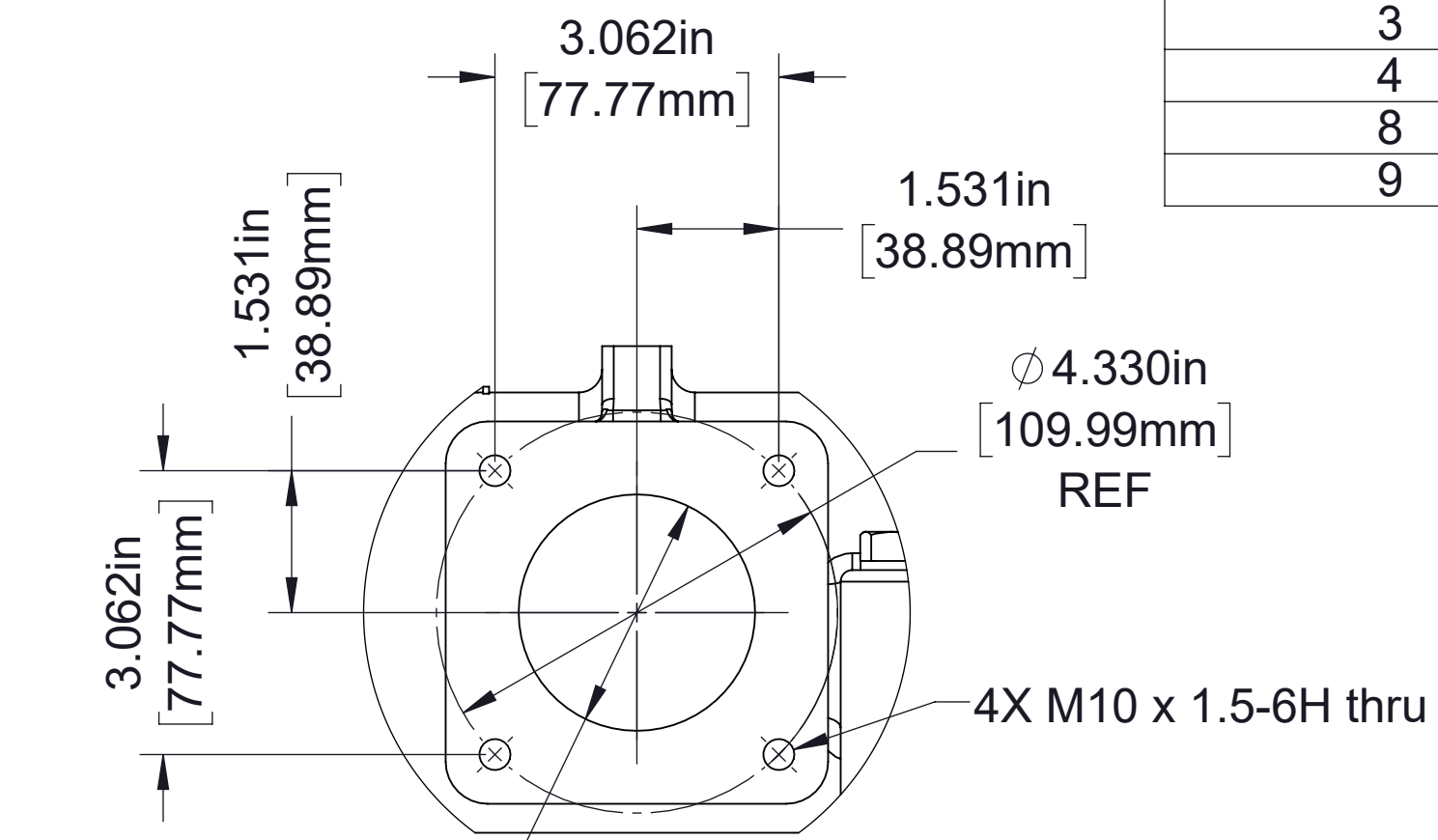

Detail C

65 mm 4-Bolt
See page 9 for auxiliary fittings
which may be mounted on this pad

Opening Diameter,
See Table

4.330in
[109.99mm]
REF

4X M10 x 1.5-6H thru

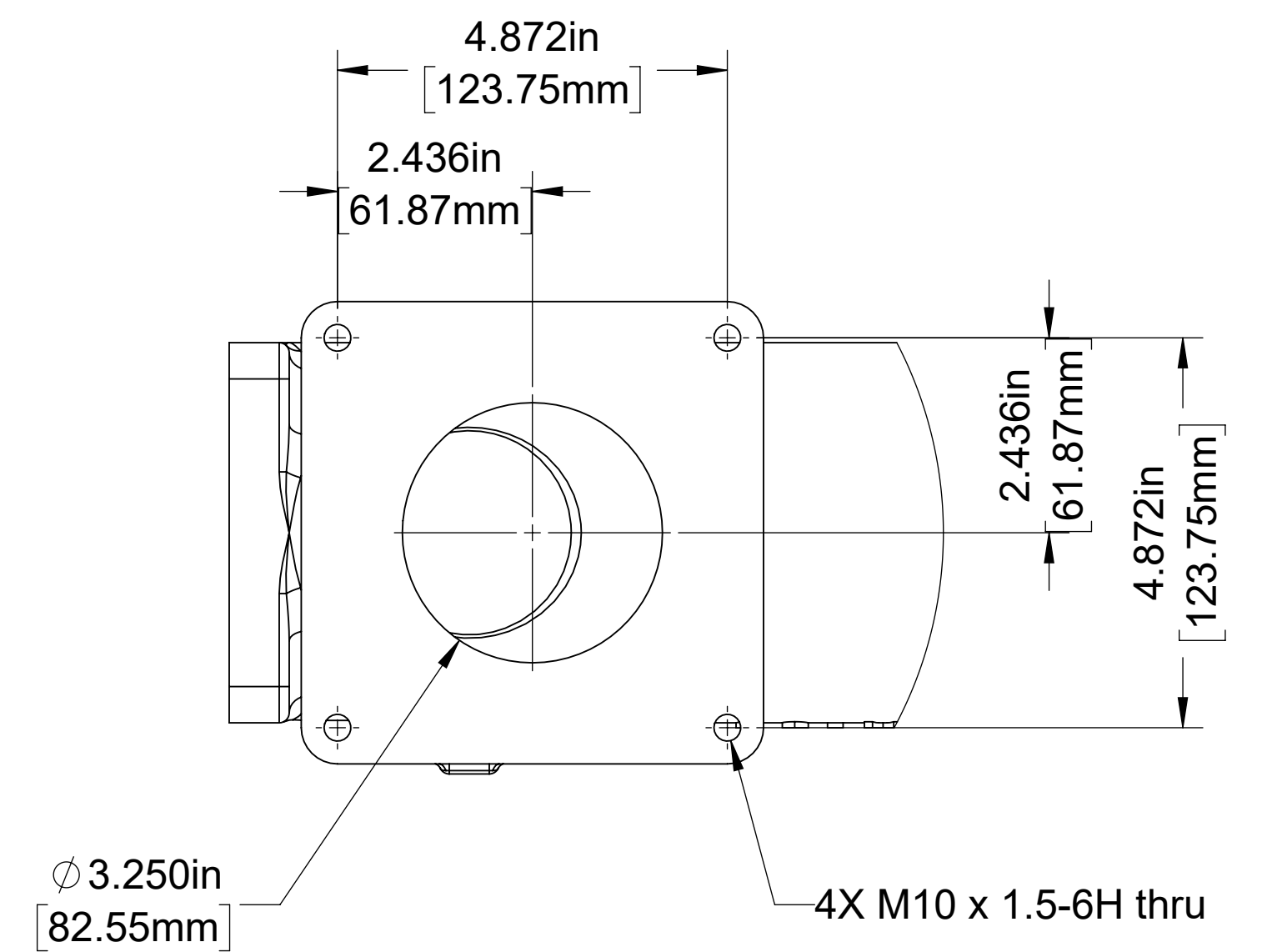

View D-D

80 mm 4-Bolt
See page 9 for auxiliary fittings
which may be mounted on this pad

3.250in
[82.55mm]

4X M10 x 1.5-6H thru

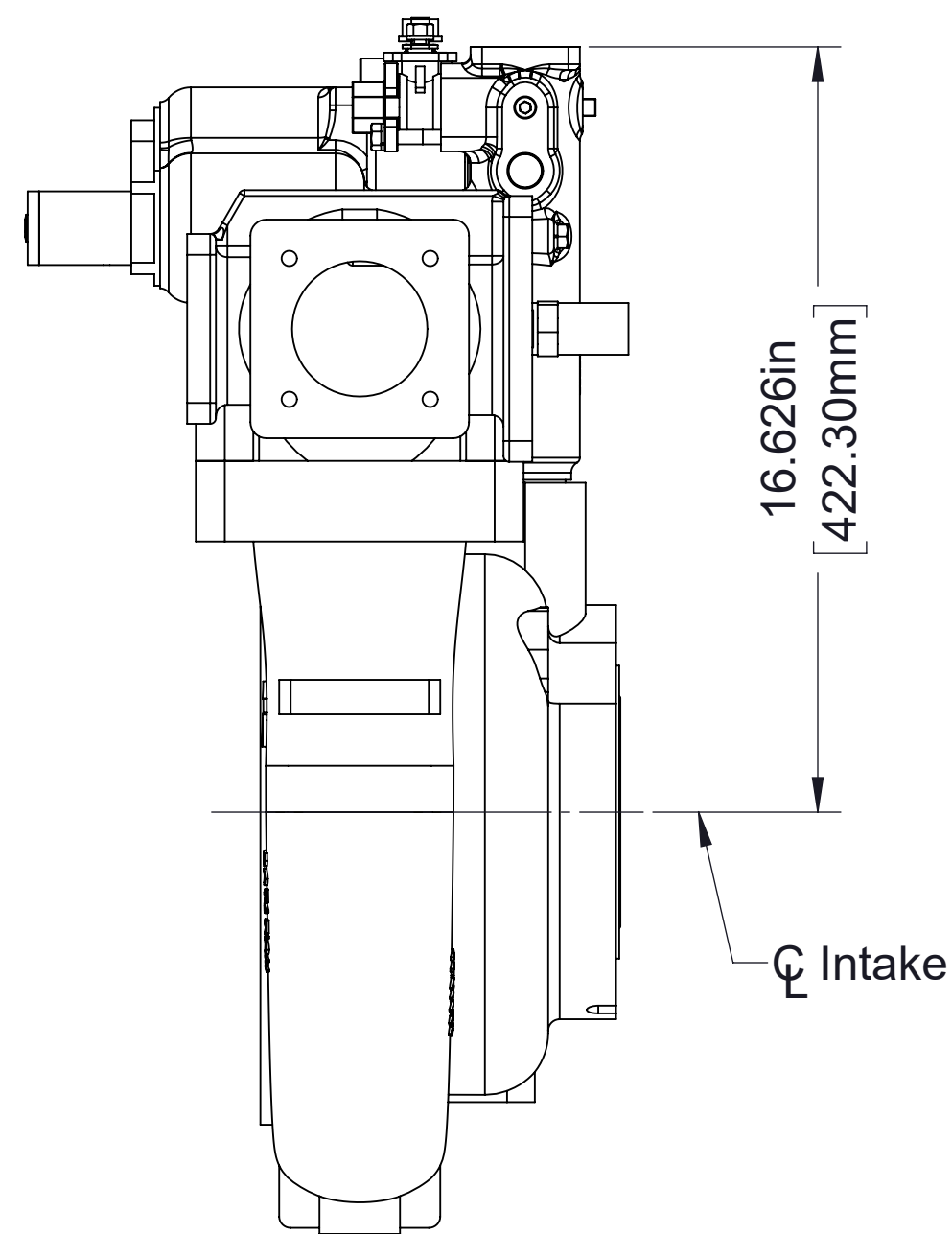
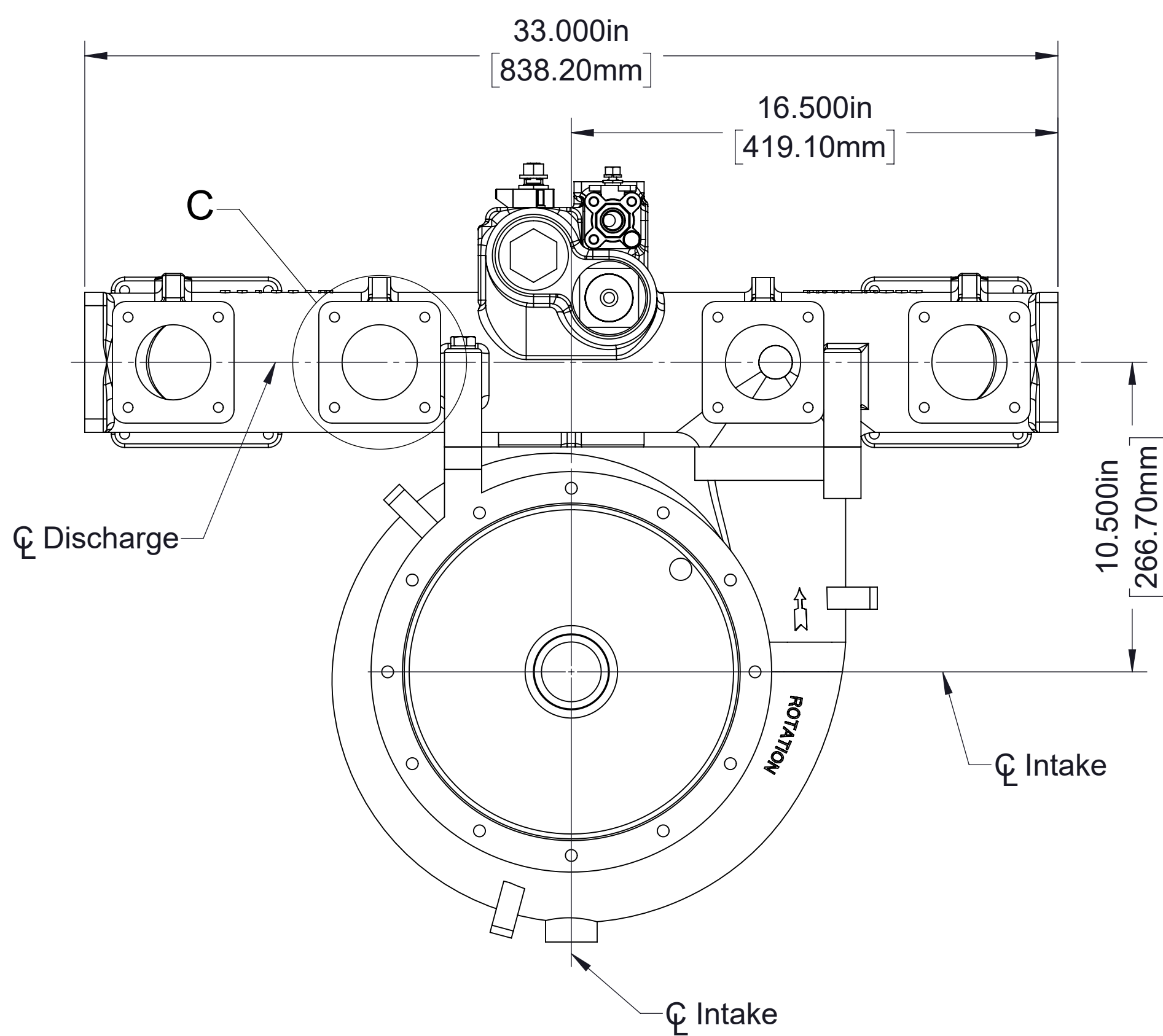
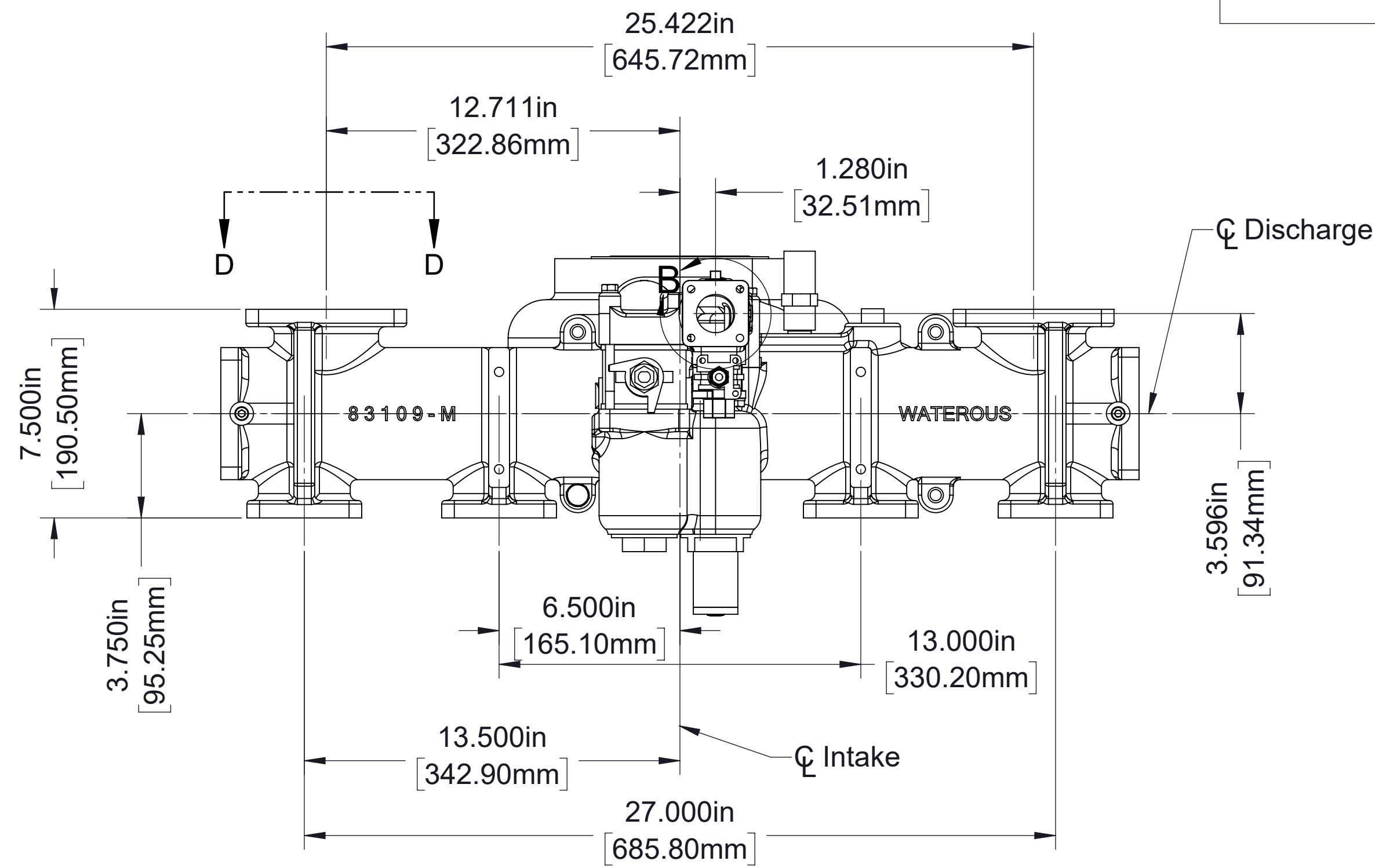

Discharge Manifold

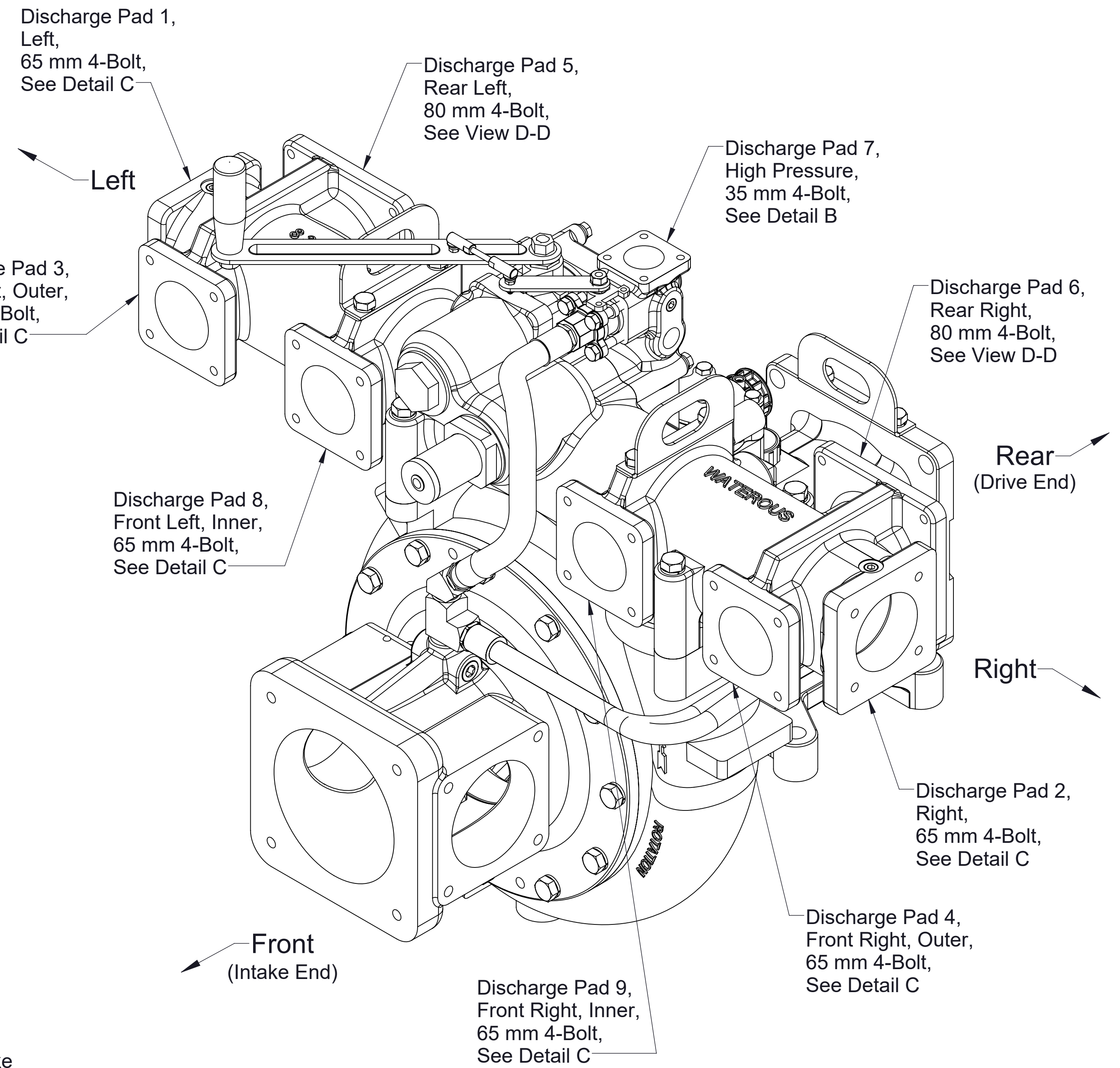

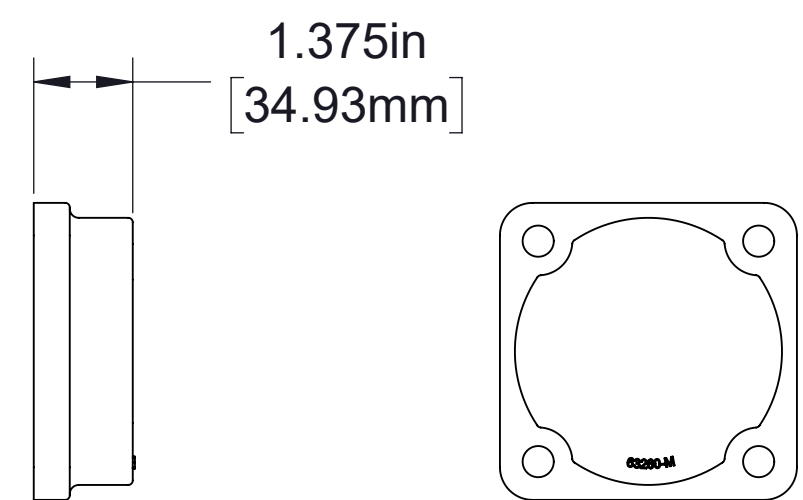

Blind Flange

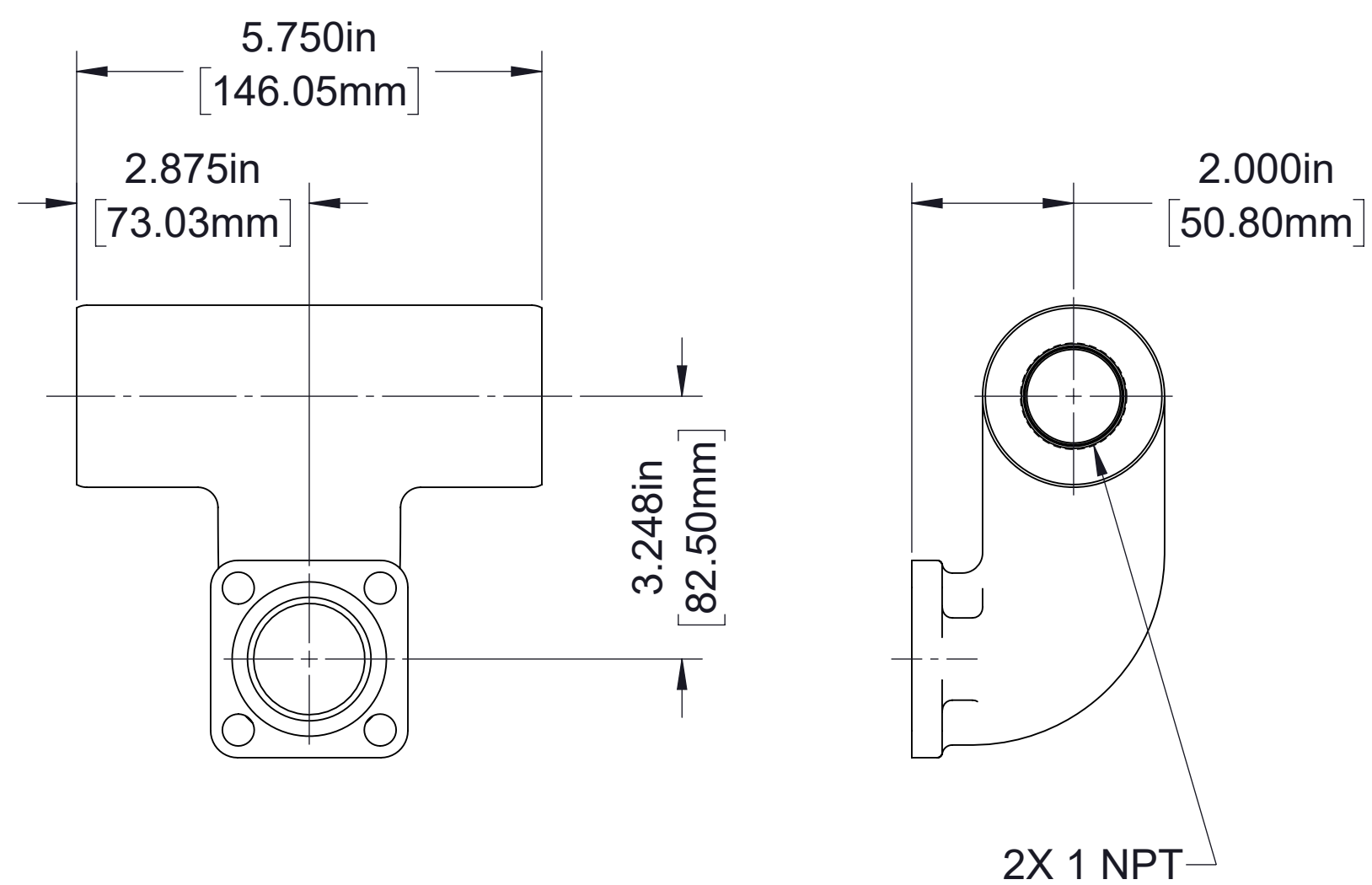

Manifold

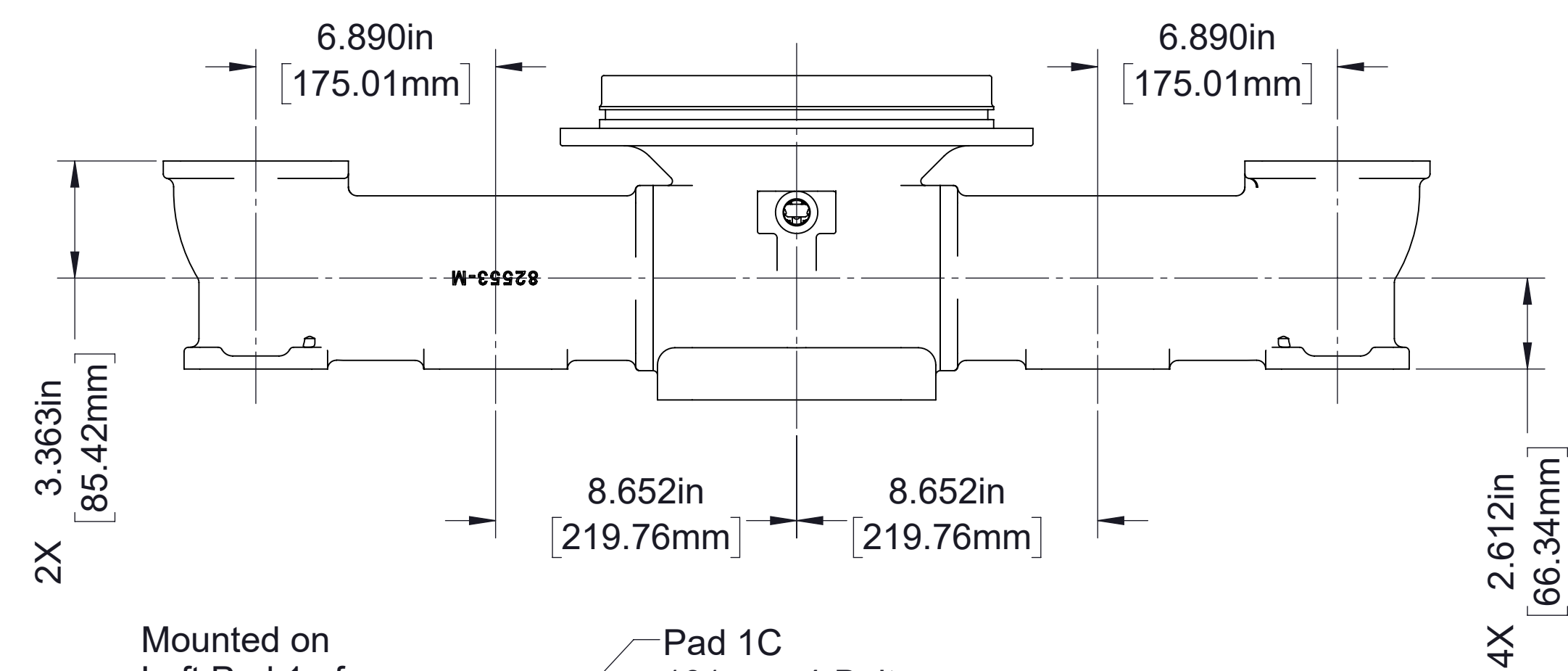

Optional Intake Manifold

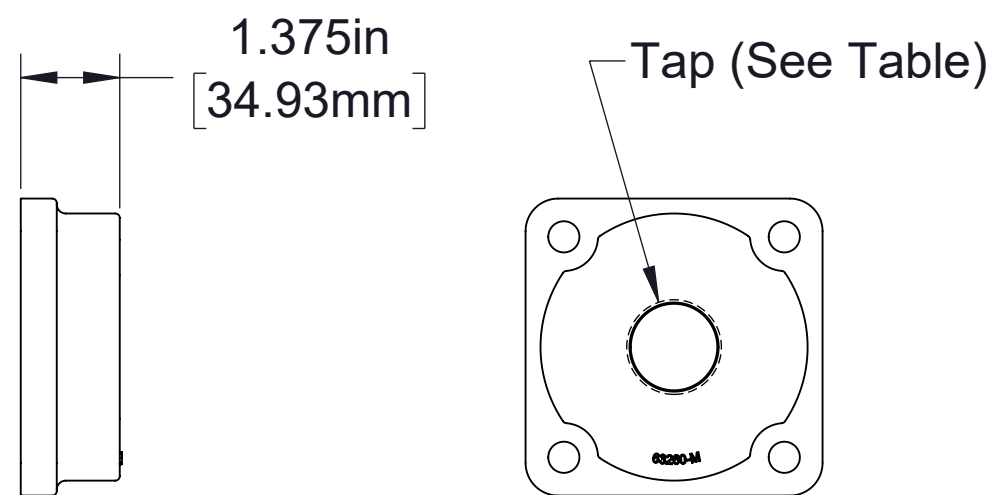
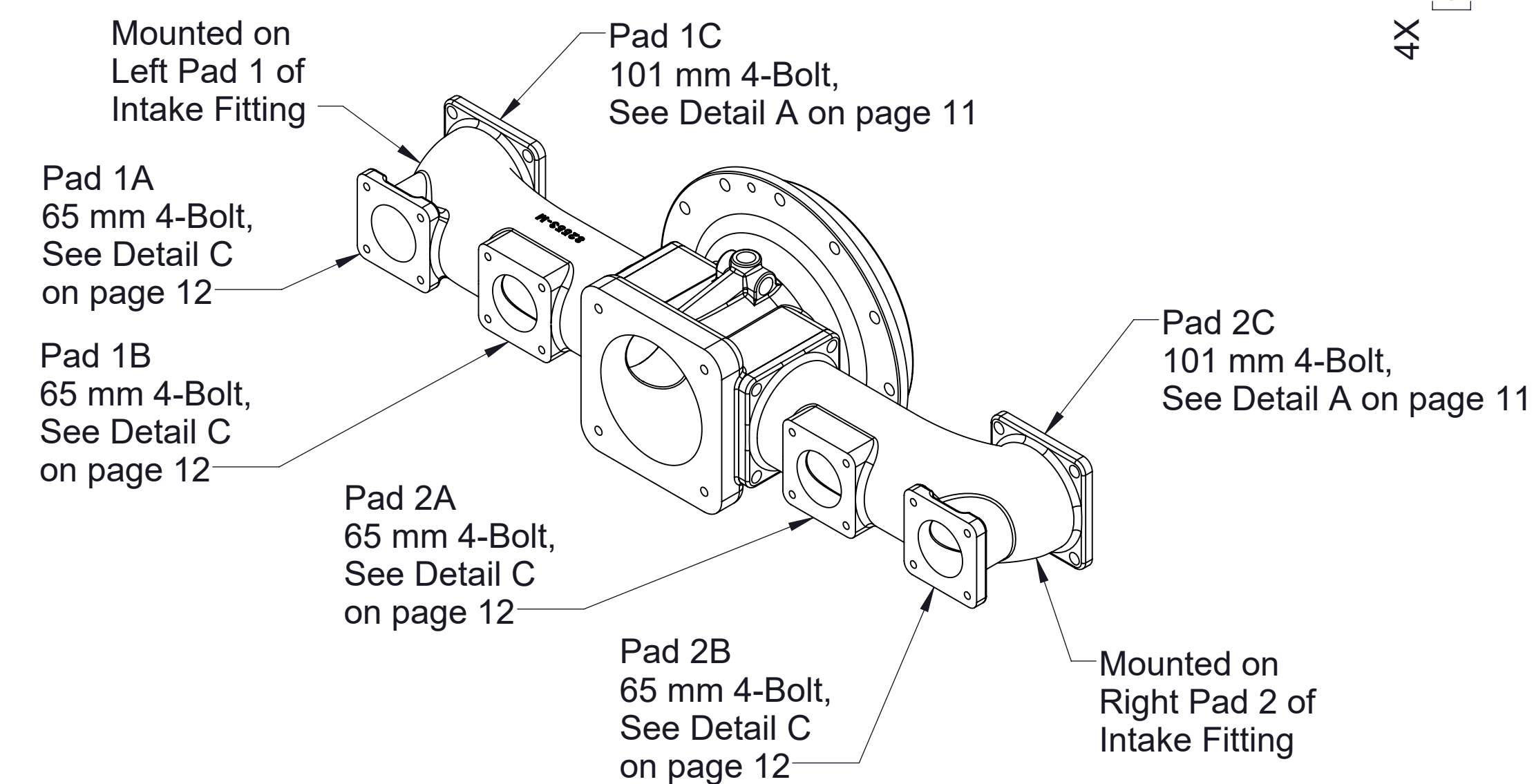

Tap Options
1 in NPT
1-1/2 in NPT
2 in NPT
2-1/2 in NPT

Tapped Flanges

65 mm 4-Bolt Fittings

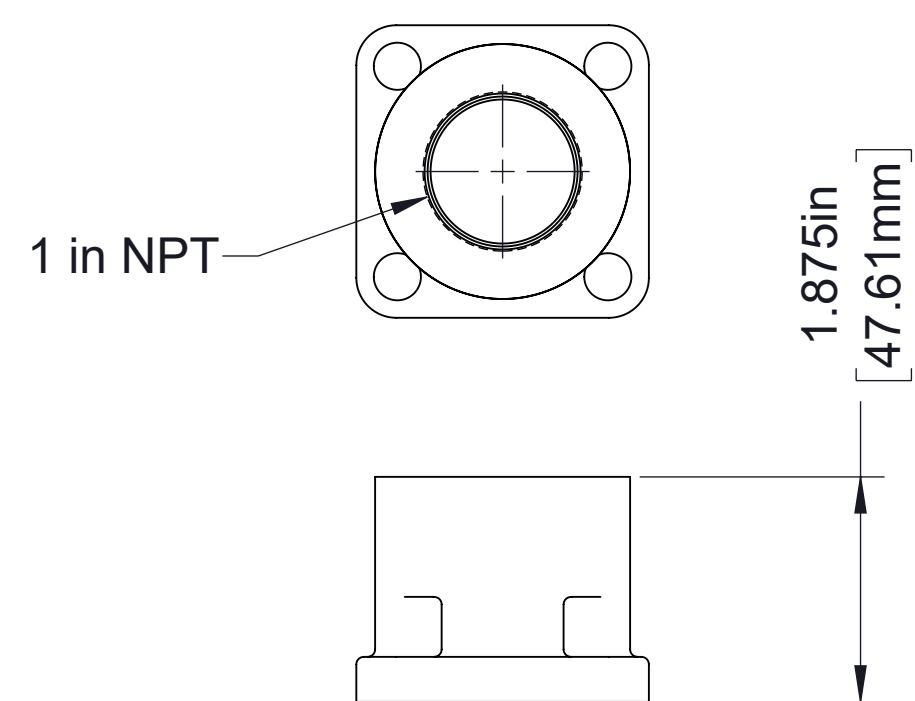

Tapped Flange

35 mm 4-Bolt Fittings

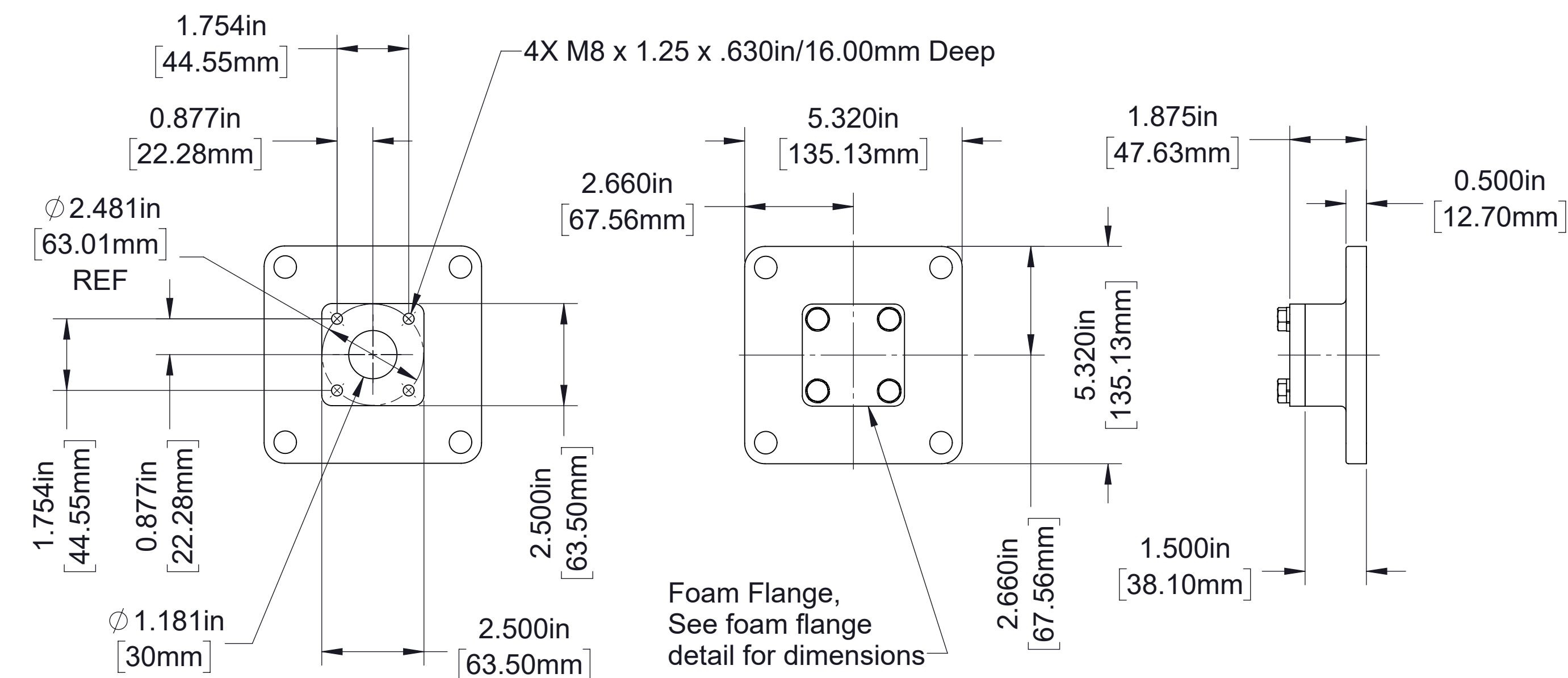

Foam Flange

Foam Flange with Blind Foam Pad

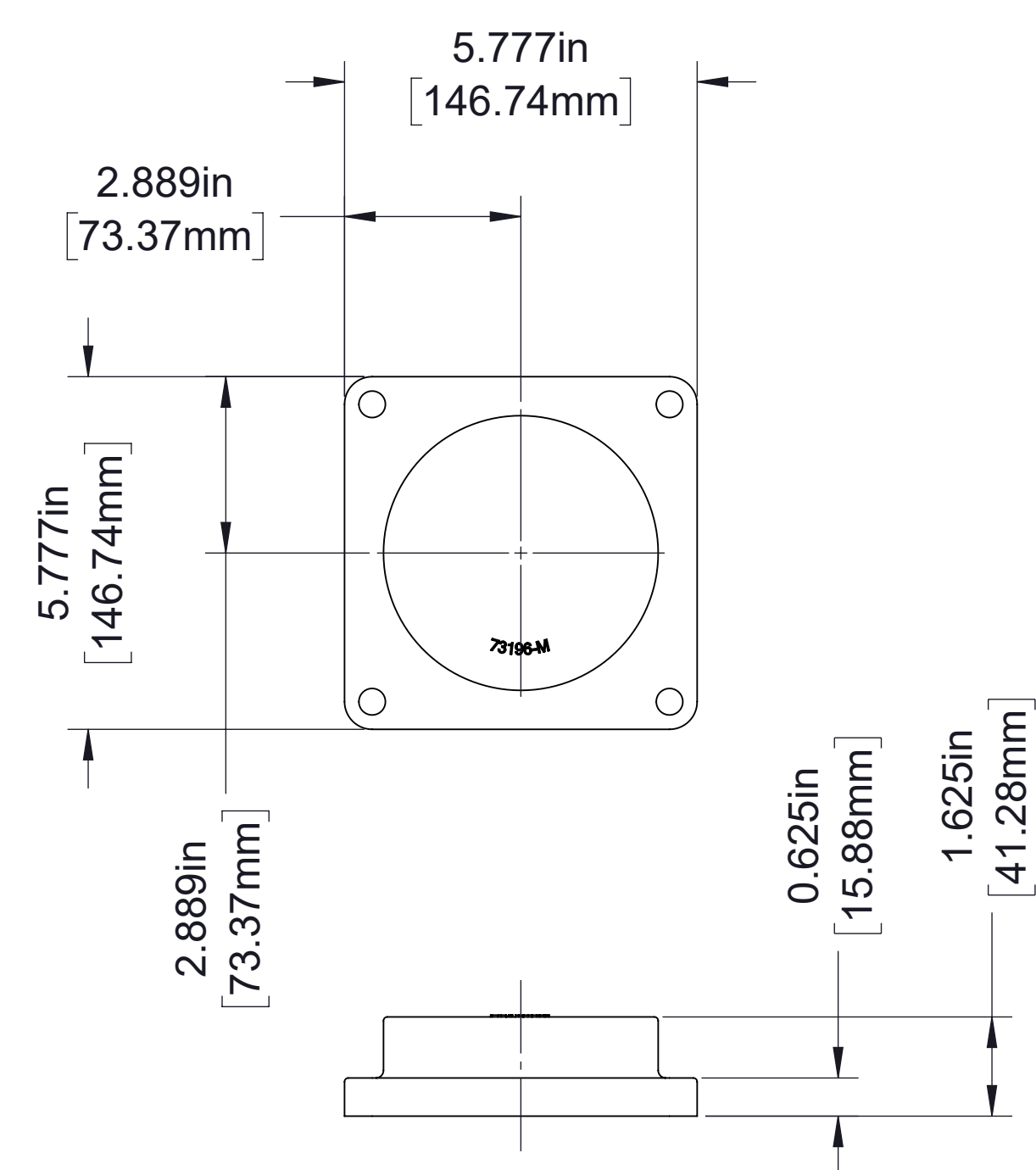

Blind Flange

80 mm 4-Bolt Fittings

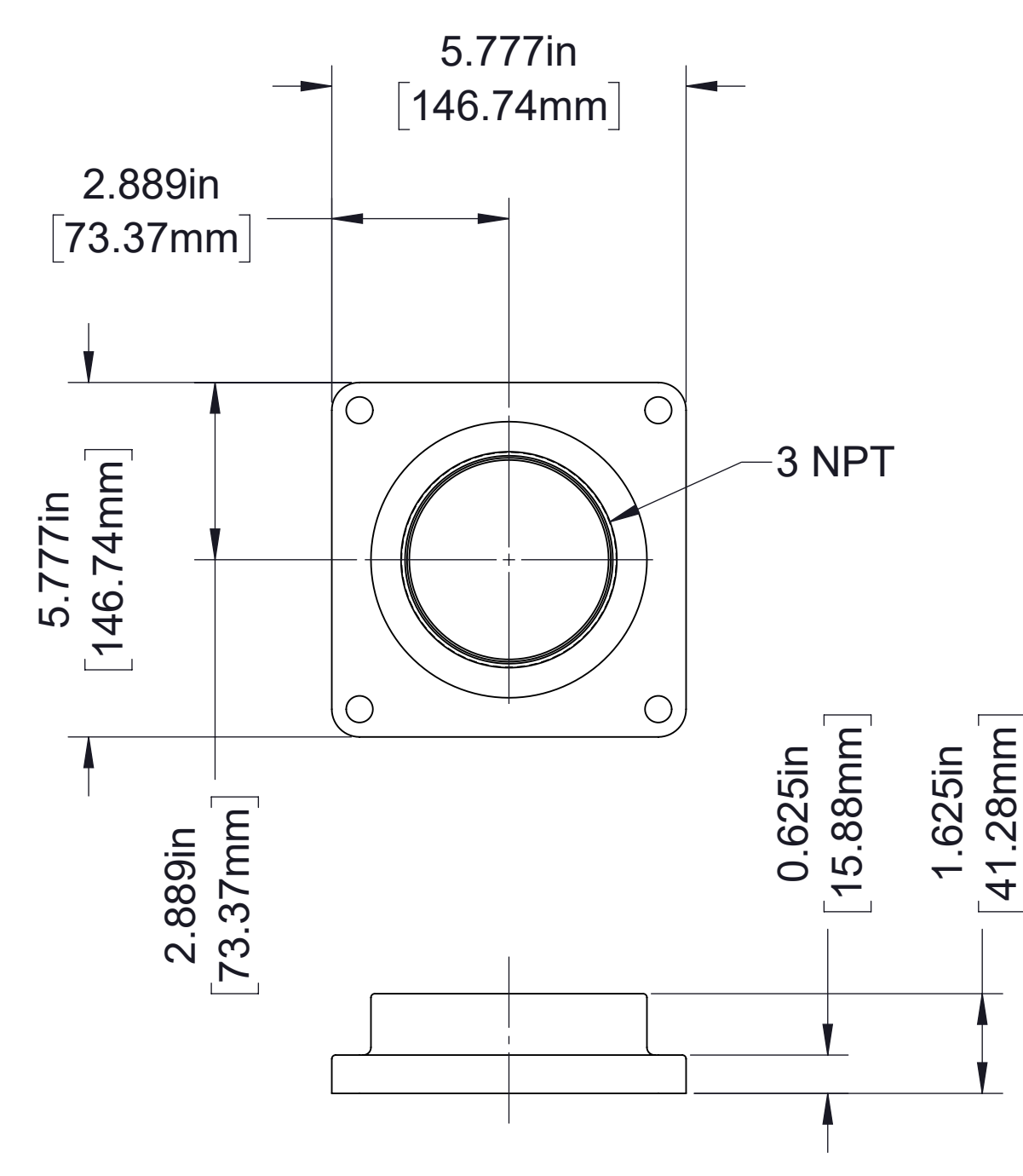

Tapped Flange

Auxiliary Fittings

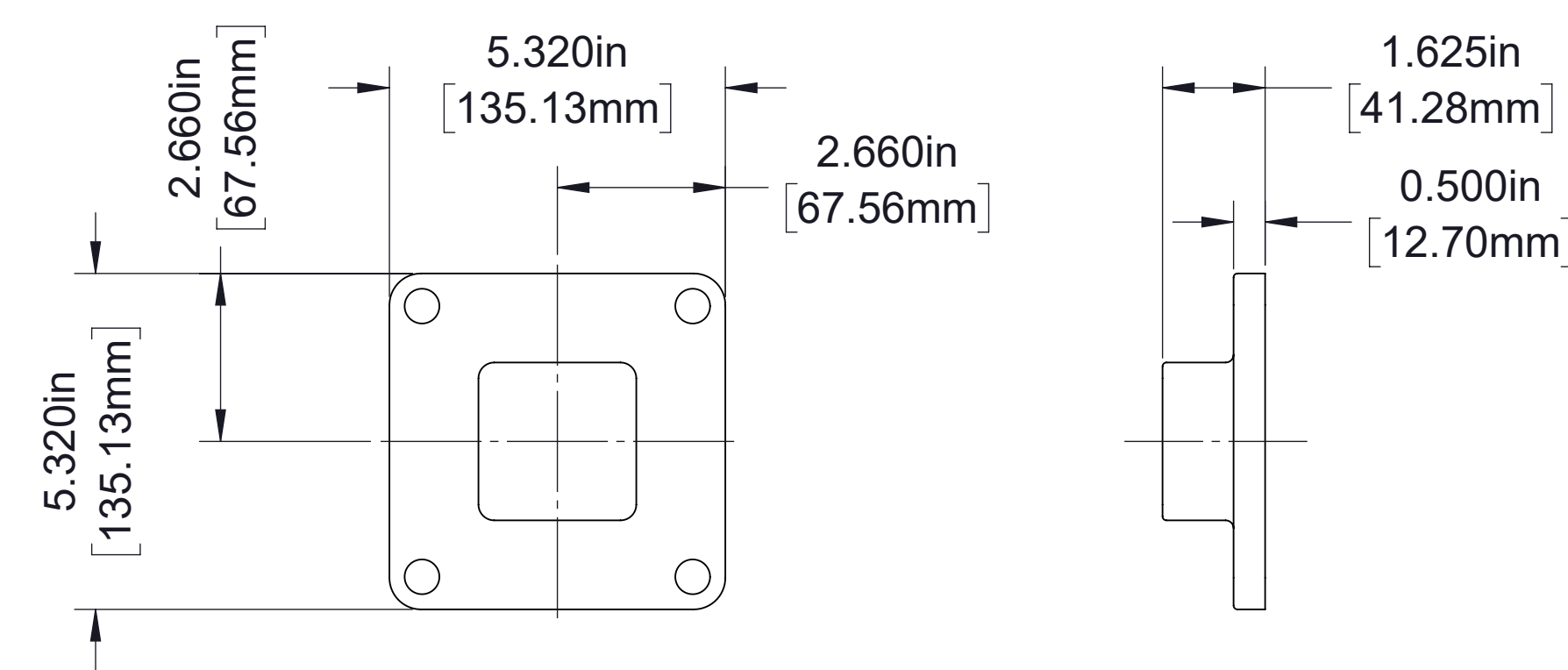

Blind Flange

101 mm 4-Bolt Fittings

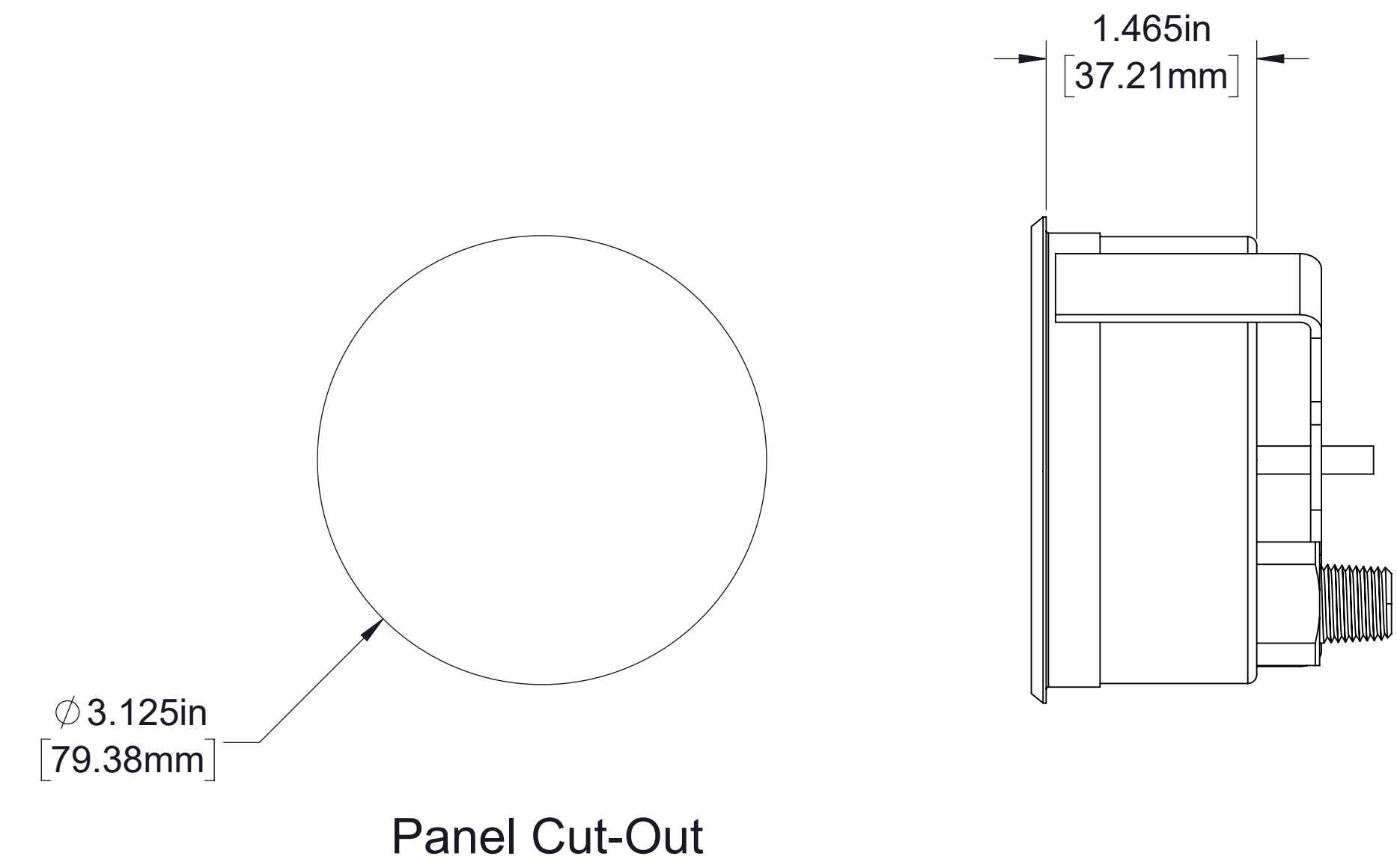
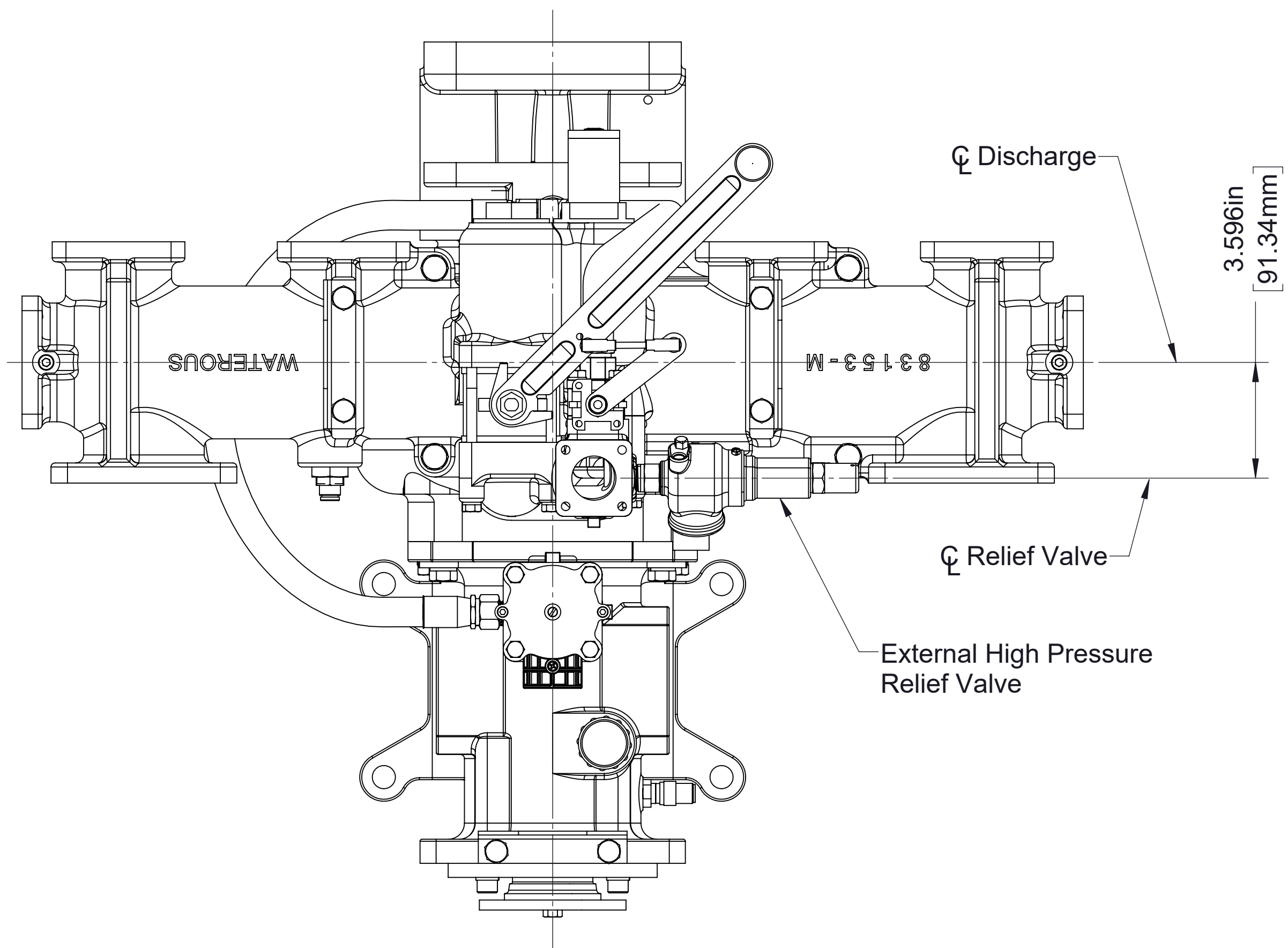

Type	Range	Part Number
Compound	-30 to 400 psi	V4228
Pressure	0 to 400 psi	V4229
	0 to 1500 psi	V4230

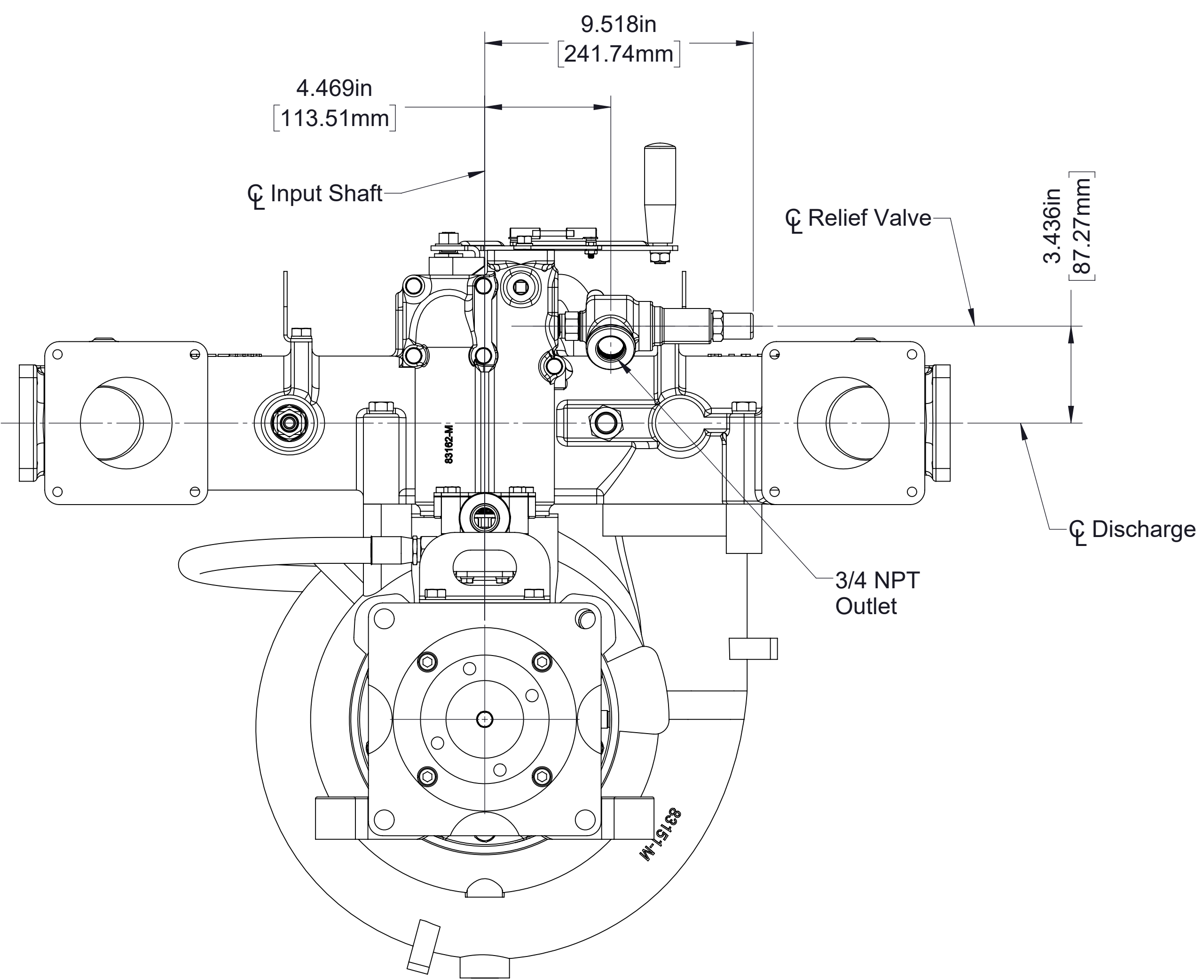

External High Pressure Relief Valve

HLUD Pump with Counter-Clockwise
Input Rotation Shown

Optional Gauges

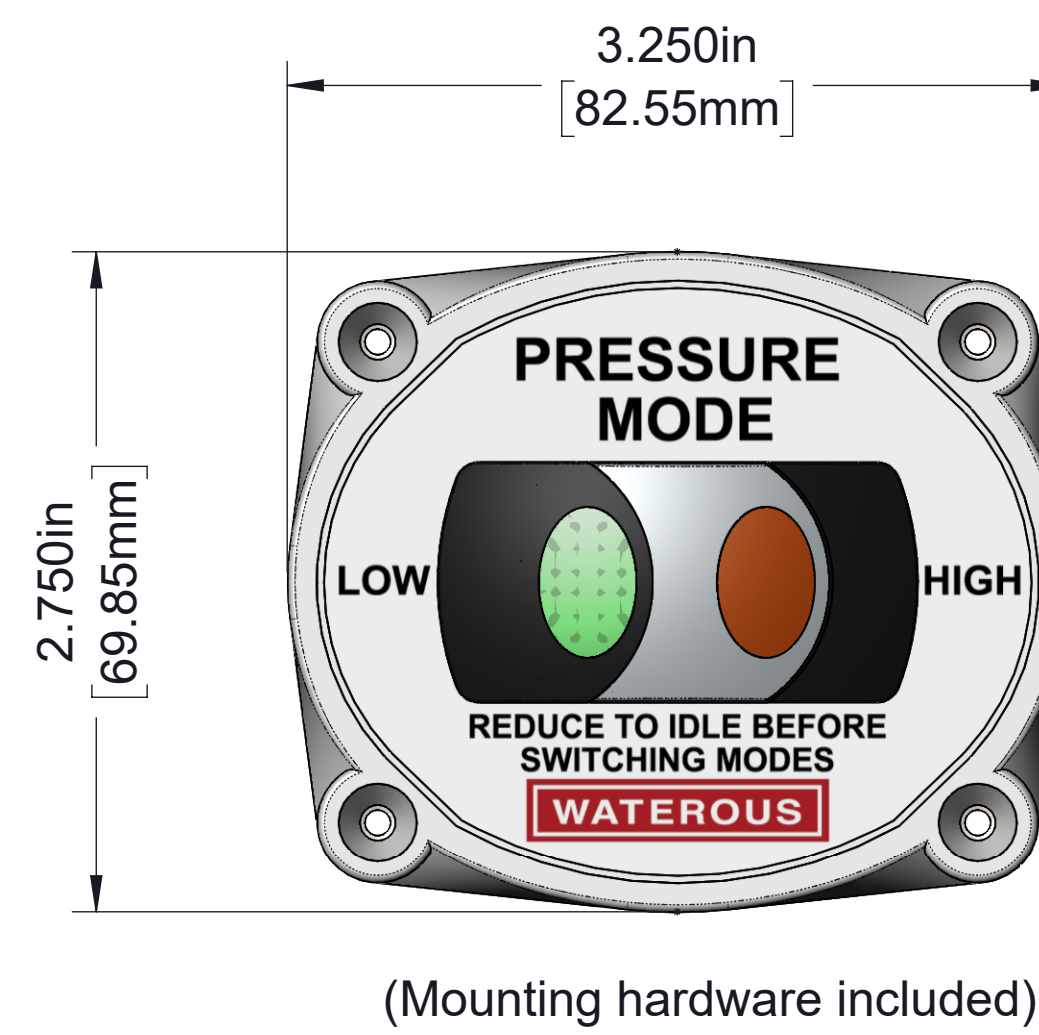

Pressure Mode Controller

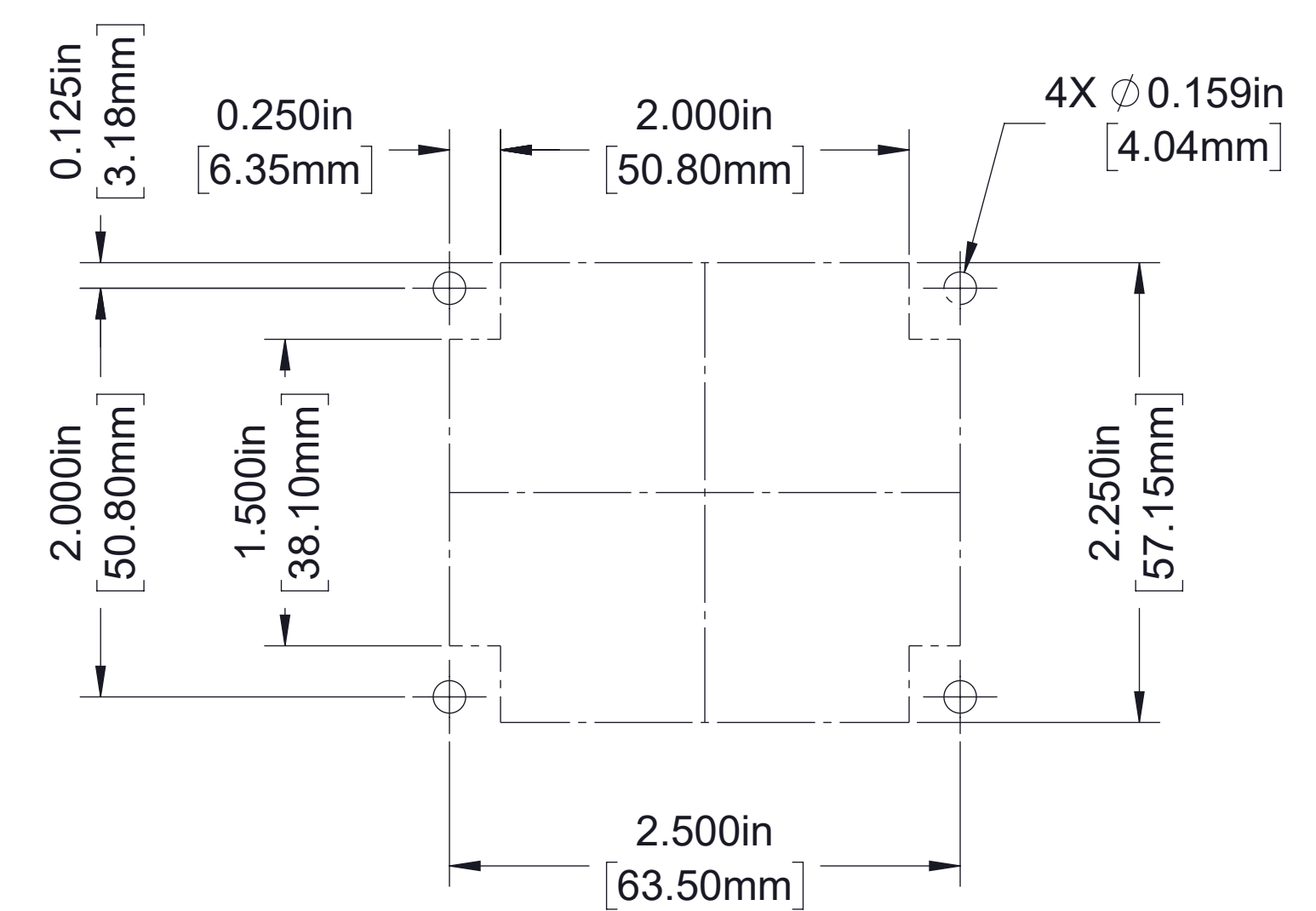

Panel Hole Layout