



SPECIFICATIONS – TRANSMISSIONS: MODEL PA High-Strength, High-Performance Transmission

The PA transmission is designed to drive Waterous midship pumps off the ten bolt, power take-offs (PTO) available on the left side of an Allison MD or HD automatic transmission. The largest capacity pump that can be driven with the PA transmission depends on the maximum torque limits of the PTO's. The manufacturers of the PTO's should be consulted for the fire truck heavy duty power and speed ratings when selecting a pump/transmission combination to be used. Several different speed increasing ratios are available with the PA transmission to accommodate various PTO drive applications. The PA transmission body is made entirely of lightweight cast aluminum alloy. The shafts, sprockets and chain are steel. It utilizes the same proven chain design used in the dependable, Waterous C10 series pump transmissions. This design provides the smoothest and quietest transfer of power. The chain is lubricated by means of a passive oil system as well as the splash oil system. Ball bearings are used on the two shafts to provide smooth, long lasting service. The input shaft has a 1-1/2-10 SAE spline. The driven shaft of the PA transmission uses the same design as our C10 series transmission. This special design consists of a two-piece impeller shaft that is separable between the pump and pump transmission, allowing for individual repair of either pump or transmission, and keeping down time to a minimum.



Specifications:

Case:

Cast aluminum alloy

Driveline:

1-1/2 -10 SAE spline

Optional Rear Facing Output:

1-3/8 -10 SAE spline or 1-1/4 in. round-keyed for driving an air compressor

Ratios:

1.71, 1.91, 2.05

Input Torque Limit:

600 ft-lb

Bearings:

Oil lubricated ball bearings throughout.

Gears: Constant mesh helical, alloy steel. All gears are crown shaved, carburized and hardened. The bores are precision ground.

Chain:

Morse H-V[®] high strength silent chain

Lubrication:

Passive lubrication system eliminates need for a separate oil pump.

Tachometer:

Electric Tachometer Sensor (standard).

Approximate Dimensions and Weights:

Ratio	A (in/mm)	B (in/mm)	C (in/mm)	D (in/mm)	Weight (lb/kg)
1.71	11.364 / 288.65	11.020 / 279.92	8.169 / 207.49	4.886 / 124.11	106 / 48
1.91	11.438 / 290.53	11.092 / 281.73	8.098 / 205.68	4.812 / 122.22	
2.05	11.142 / 283.00	10.816 / 274.72	8.373 / 212.68	5.108 / 129.75	

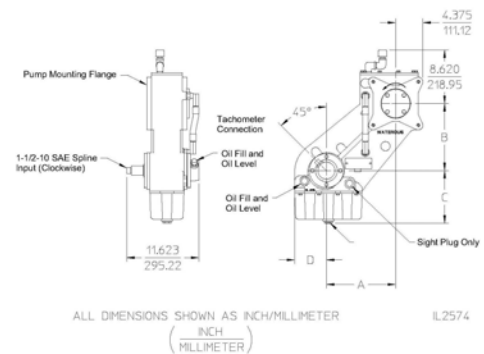

Industry-Leading Sales and Support

When you purchase Waterous equipment, not only do you get quality products, you get quality service. Our expert service technicians are the best in the business and they are always happy to answer any service questions you might have.

Sales/Applications Assistance

Phone: 651-450-5234 (Press 3)
pumpsales@waterousco.com

Service Assistance

Phone: 651-450-5200
Fax: 800-488-1228
service@waterousco.com