

Foam Manager™ System with Aquis™

Operation and Maintenance

Form No.	Section	Issue Date	Rev. Date
F-1031	2414	03/11/10	05/13/13

Table of Contents

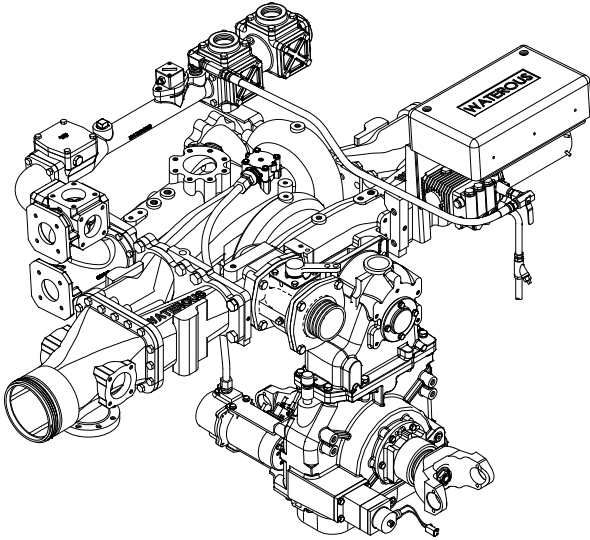

IL3436

Safety Information	2
Introduction	3
System Overview	3
System Components	4
Operation	4
Water Only Operation	4
Aquis™ Foam Pump Operation	5
Foam Operation	6
Shut Down Procedures	6
Foam System Flush	6
Service and Maintenance	6
Maintenance Schedule	6
Location of Maintenance Items	6
Advantus Foam Pump	6
<i>Oil Fill and Drain</i>	6
<i>In-line Foam Concentrate Strainer</i>	6
Calibration	7
Aquis Foam Pump	7
Troubleshooting Guide	8



Read through the safety information and operating instructions carefully before using your Waterous Foam Manager.



Visit us at www.waterousco.com

Safety Information



Read through the safety information and operating instructions before using your Waterous Foam Manager.

WARNING

Death or serious personal injury might occur if proper operating procedures are not followed. The pump operator, as well as individuals connecting supply or discharge hoses to the apparatus must be familiar with these pump operating instructions as well as other operating instructions and manuals for the apparatus, water hydraulics and component limitation.

WARNING

Pressure Hazard. May result in personal injury.

Prior to connection or removal of hoses, caps or other closures with pump intake or pump discharge connections, relieve pressure by opening drains or bleeder valves. Bleeder valves should also be used while filling a hose connected to an intake with water.

WARNING

Scalding Water Hazard. May result in serious burns.

When operating the pump, be sure to open at least one discharge valve slightly to prevent the pump from overheating. If the pump runs for a few minutes completely closed, it may heat the water enough to scald someone when the valve is opened. Overheating can damage the packing, seals and other pump parts. If the apparatus builder has installed a by-pass system or other provision designed to prevent overheating, opening a discharge valve may be unnecessary.

WARNING

Hose Pressure Hazard.

May cause serious personal injury.

Use only fire hose that is rated at 200 PSI or higher working pressure.

Introduction

System Overview

NOTE: Read and understand the operating instructions for the Foam Manager System prior to operating. (Refer to Figure 1 for system components.)

The Foam Manager™ System consists of an Aquis™ Foam Proportioning System mounted on a Waterous CM or CS fire pump.

Aquis™ 2.5 Foam Proportioning System

The Aquis foam proportioner from Waterous delivers a level of performance and reliability typically reserved for more expensive Class A foam proportioners. Aquis 2.5 features a non-corroding brass body pump as well as sensors that measure water temperature and water flow to create the ideal water to concentrate ratio for superior foam.

Foam Pump

The 12 or 24-volt, electric motor driven, positive displacement triplex plunger foam pump is equipped with an aluminum crankcase, ball bearings, forged brass pump body and manifold, solid ceramic plungers, stainless steel check valves and piston guides, Buna packing and preset thermal and pressure relief valves.

The foam pump is rated at 2.5 GPM @ 150 psi (9.46 l/min @ 10 bar) with operating pressures up to 450 psi (32 bar). Maximum electrical load of 40 amps @ 12 VDC and 21 amps @ 24 VDC.

A pump motor electronic driver, located inside the controller housing, receives signals from the microcontroller and powers the 1/2 hp (.4 kW) electric motor in a variable speed duty cycle to ensure that the correct amount of foam concentrate set by the pump operator is injected into the water stream.

System Components

Table 1. System Components

Ref. No.	Description
1	Aquis™ Foam Pump (Proportioner)
2	Foam Pump Inject Valve
3	In-line Foam Concentrate Strainer

Ref. No.	Description
4	Aquis™ Foam Pump OIT (Control Panel)
5	Aquis™ Operation Instruction Panel Plate
6	OIT Cable

Figure 1. System Components

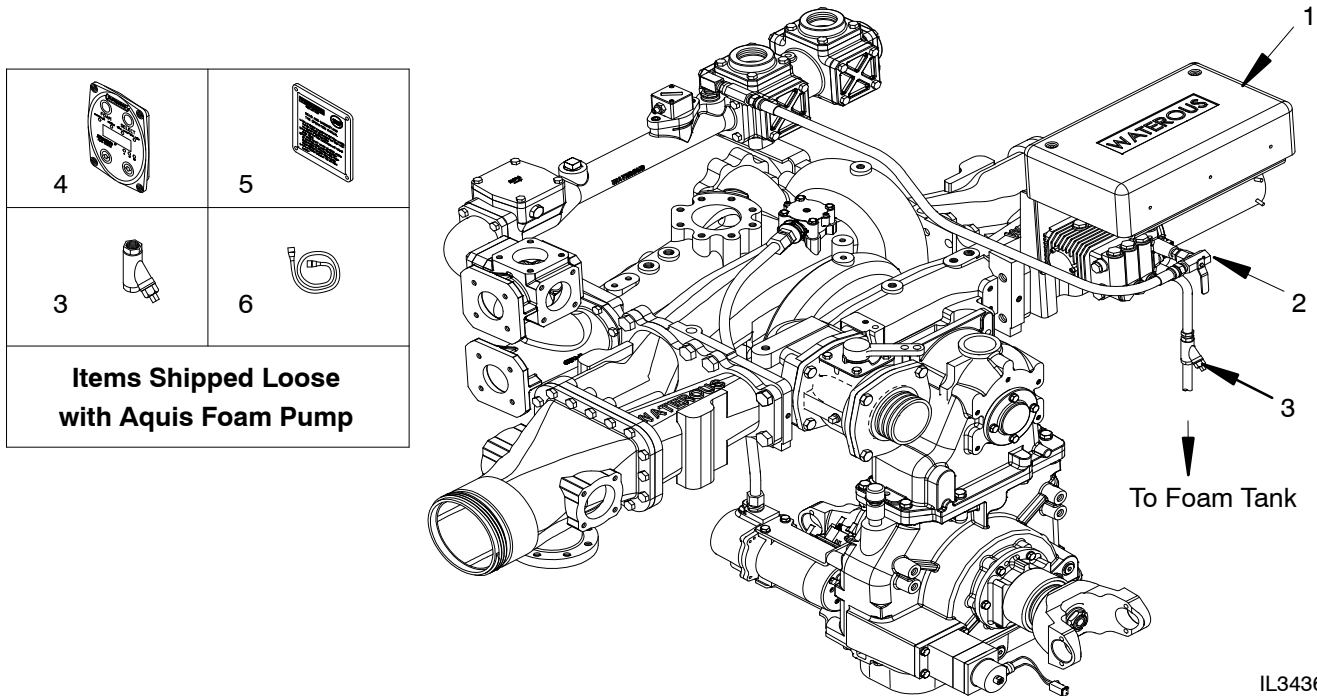

Optional Items from Waterous	
	Description
	Foam Tank Level Switch
	Aquis Rating Panel Plate
	Aquis System Schematic Panel Plate
	OIT (Control Panel) Extension Cable

Operation

A pumper equipped with a Foam Manager™ foam unit can be operated in water only and/or foam modes. It is pos-

sible to pump water from one discharge and foam solution from another discharge.

Water Only Operations

All unit operations begin with pumping water. See the following instruction for details on how to operate and pump water from your Waterous fire pump:

- F-1031, Section 2114, *Operation and Maintenance Instructions for Waterous CMU Series Centrifugal Fire Pumps*
- or
- F-1031, Section 2115, *Operation and Maintenance Instructions for Waterous CS and CSU Series Centrifugal Fire Pumps*

CAUTION
<p>Overheating hazard. May cause damage to the pump.</p> <p>Running the unit without adequate water flow or an overheated water supply can cause damage to the pump.</p>

Aquis™ Foam Pump Operation

Upon power up, the software revision number will be displayed. The unit will then display the flow rate.

The software will perform a linear interpolation to determine values to use for flow rates that are in between flow rates entered in the data array.

Figure 2. Operator Interface Terminal

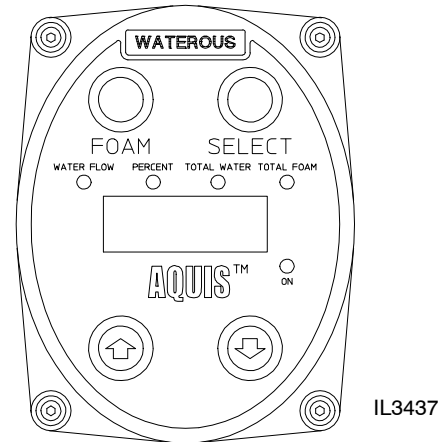

During normal operation, the OIT (Operation Interface Terminal) will display flow rate, percent mix, total water or total product.

<p>SELECT</p>	<p>Selects data to display. The default is to display flow rate. Pressing the SELECT button will scroll through the list, then wrap back around to the top of the list. The associated LED will light to indicate what data is being displayed.</p> <ul style="list-style-type: none"> Flow Rate Mix Percentage Total Water Total Product <p>Holding the SELECT button for more than two (2) seconds will lock the display to the current position. Pressing the SELECT button again will unlock.</p>
<p>UP ARROW</p>	<p>When the Mix Percentage is displayed, the current mix setpoint will be displayed. Subsequent presses of the UP ARROW button will increase the Mix Setpoint by 0.1%. After a ten (10) second timeout, the display will return to the Flow Rate display.</p>
<p>DOWN ARROW</p>	<p>When the Mix Percentage is displayed, the current mix setpoint will be displayed. Subsequent presses of the DOWN ARROW button will decrease the Mix Setpoint by 0.1%. After a ten (10) second timeout, the display will return to the Flow Rate display.</p> <p>Pressing both UP and DOWN simultaneously when the Total Water is displayed resets the Total Water accumulator to Zero.</p> <p>Pressing both UP and DOWN simultaneously when the Total Product is displayed resets the Total Product accumulator to Zero.</p> <p>Pressing both UP and DOWN simultaneously for two (2) seconds, when the Flow Rate is displayed enters the MANUAL mode of operation. See Manual Mode operation below.</p> <p>Pressing both UP and DOWN simultaneously while in Mix % will go to the preset default %.</p>
<p>FOAM</p>	<p>Pressing the FOAM button will alternately start and stop the foam operation. When the controller is running, the FOAM LED will be lit. The FOAM LED will blink when the motor control output is active.</p>
<p>MANUAL MODE</p>	<p>If the display is showing the flow rate and the two ARROW keys are pressed simultaneously, held for two (2) seconds, the % MIX LED will light and the display will show a default value of 2.0. Use the UP and DOWN arrow keys to increase or decrease this value in steps of 0.5.</p> <p>NOTE: Pump output is based on a theoretical ratio of foam to water at 50 GPM.</p> <p>Pressing both ARROW keys again exits the MANUAL mode and stops the pump.</p> <p>While in manual mode, you can pause the motor by pressing the RED FOAM button (once). You can increase or decrease the foam percentage at this time. Resume foam flow by pressing the RED button once.</p> <p>Pressing both ARROW keys again exits the MANUAL mode and stops the pump.</p> <p>NOTE: Motor/Pump Assembly will operate in MANUAL mode whether or not there is a water flow. If the INJECT/BYPASS valve is in the INJECT position, foam concentrate will be injected into the system, which will waste foam concentrate.</p>
<p>AUTO RUN</p>	<p>The system is equipped with an AUTO RUN feature. If the voltage (+12 or 24 VDC) is applied to position 1 on the terminal strip, it will have the same effect as pressing the Red FOAM button. This will start the Foam system. The system will not inject foam until water is flowing.</p>

Foam Operation

After the pump is operating, turn on the foam pump to inject foam concentrate into the water stream.

Refer to Aquis Foam Pump Operation Instructions on Page 4.

Foam System Flush

1. Turn off Foam Pump.
2. Flow clear water through discharges that were used until clear water is flowing from the nozzle.

Service and Maintenance

Maintenance Schedule

Table 2. Maintenance Schedule - Foam Pump (See Figure 3)

Check Oil Level and for Oil Leaks	Foam Pump Oil					Check and Clean Foam Concentrate In-line Strainer	Flushing System
	Change	Foam Pump Model	Level from Top of Oil Fill Port	Capacity Required for Oil Change	Use Oil		
Daily or After Each Use	Annually	Aquis 2.5	1/4 inch (6 mm)	.90 quarts (Total capacity is 1.0 quart)	Synthetic 10W-30 (Mobil 1 recommended)	Monthly	Depending on the corrosiveness of the foam concentrate to be used, flushing of the foam injection circuit may be necessary. Most Class A foam concentrates are less corrosive and may not require flushing.

Location of Maintenance Items

The following figures show the location of the Aquis™ Foam Pump oil fill and drain.

Figure 3. Aquis™ Foam Pump Oil Fill and Drain, In-line Foam Concentrate Strainer

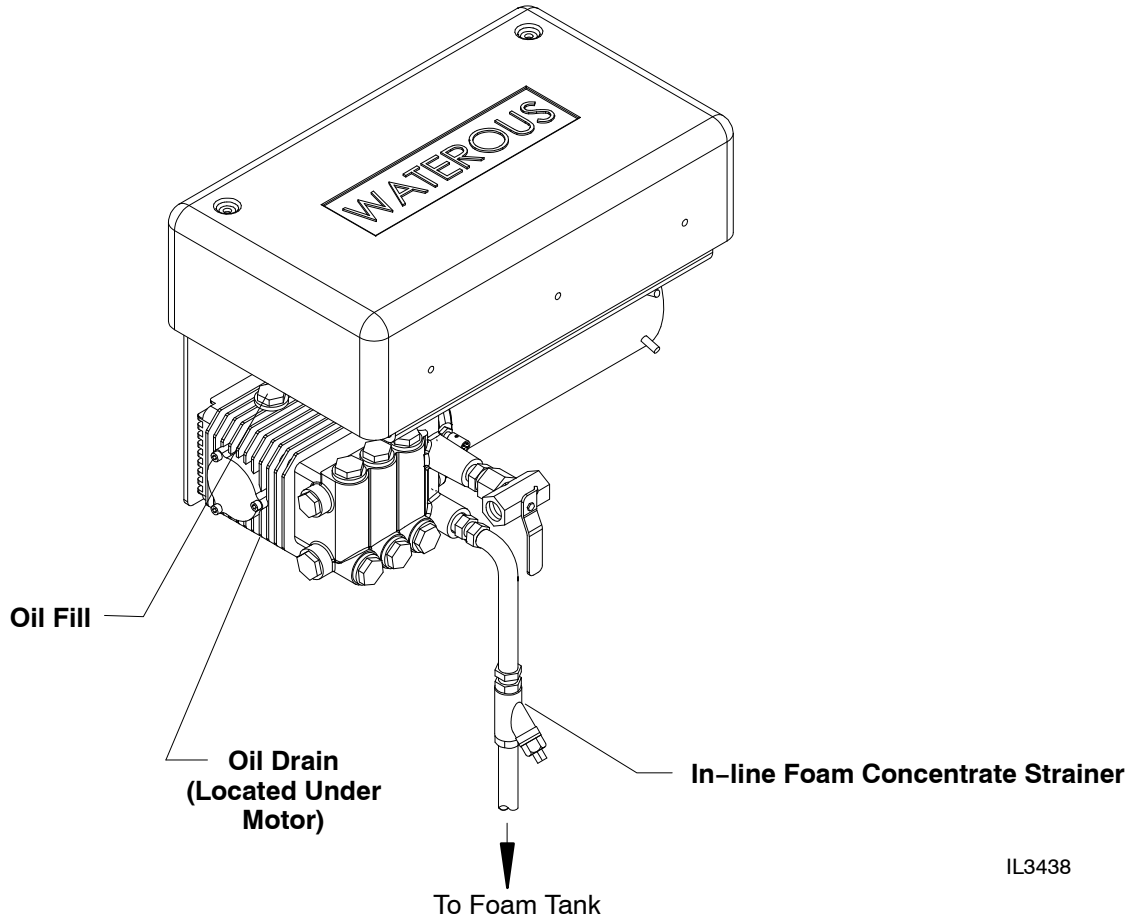

IL3438

Calibration

Aquis™ Foam Pump

The Aquis™ system is able to be field calibrated using the control function buttons on the operating interface terminal (OIT), see Figure 8.

Only units of measure, water flow and the foam percentage default can be field set.

A. Entering Calibration Mode

1. Entering calibration is accomplished by using the control unit functions buttons.
2. To enter this function, press and hold the **SELECT** button for minimum of five (5) seconds. The OIT will display "5 SEC".
3. Continue to hold the **SELECT** button.
4. While the **SELECT** button is depressed, push the **UP** and **DOWN** arrow buttons at the same time. The display will show **CAL** for two (2) seconds and then display **F1**.
5. Use the **UP** button to advance to the next parameter (F2, F3, F4).
6. Use the **DOWN** button to back up to a previous parameter (F2, F1).
7. To edit a parameter, press the **SELECT** button at the associated Fn prompt.

B. F1 - Default Mix Percentage

1. At the **F1** prompt, press the **SELECT** button.
2. Use the **UP** and **DOWN** arrow buttons to select the default **FOAM %**. The only foam % selections will be .1%, .2%, .3%, .4%, .5%, .6%, .7%, .8%, .9%, 1.0%, 3.0% and 6.0%.
3. When finished, press the **SELECT** button to save the displayed value.

C. F2 - Units of Measurement

The units of measurement must be selected prior to any calibration functions. Units of measurement are U.S. Gallons, Imperial Gallons and Liters.

1. Push the **SELECT** button at the **F2** prompt. The display will show the current setting.
2. Use the **UP** and **DOWN** arrow buttons to select one of the following measurement units:
 - **GAL** will select U.S. Gallons
 - **IPL** will select Imperial Gallons
 - **LTR** will select Metric Liters
3. Pushing the **SELECT** button will save the displayed selection. This will allow for calibration of the water flow in the units of measurement selected.

D. F3 - Flow Rate Calibration

1. Press the **SELECT** button at the **F3** prompt. The current measured flow rate will be displayed. Establish a flow using an accurate flow measuring device.
2. Once this is established, press the **UP** or **DOWN** button to advance to the calibration step. If the displayed flow rate is correct, press the **SELECT** button to return back to the **F3** prompt. If there is insufficient flow, the

display will show **LoFL** for two (2) seconds, then return back to the **F3** prompt.

3. The display will now display **50** (starting value) or the last calibration value entered.
4. Use the **UP** and **DOWN** arrow buttons to change the displayed value to match the actual flow rate according to the flow measuring device. If the button is only pressed momentarily, the display increments or decrements by one (1). If the button is held, the display will increment or decrement by five (5).
5. Once the correct flow is achieved, pushing the **SELECT** will save the setting and return to the **F3** prompt.

E. F4 - System Lock

System can be locked out after calibration and setup to avoid accidental changing.

WARNING

A locked out system can only be unlocked at a qualified Waterous Service Center.

1. Press the **SELECT** button at the **F4** prompt and "EnAb" (enabled) will be displayed.
2. Pressing the **UP** button will toggle between "LoC" (locked) and "EnAb" (enabled). Settings will not be permanent until the calibration settings are saved.
3. Press the **SELECT** button and "F4" will be displayed.
4. Pressing the **FOAM** button saves the settings, locks the system and cannot be unlocked except at a qualified Waterous Service Center.

F. Saving Calibration

To save all the calibration settings to flash memory, press the **FOAM** button while at the **Fn** (n=1-4) prompt. The data will be stored and the unit will return to normal operation.

Figure 8. Operator Interface Terminal

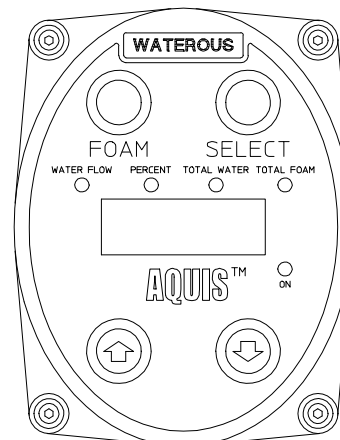

IL3437

Troubleshooting Guide

It is important to know what to do if your foam system is not operating properly. This troubleshooting guide should help you diagnose, isolate and fix the problem encountered.

Problem	Cause	Fix
Poor foam solution (wet or dry)	Using wetting agent in place of foam	Flush system and install Class "A" foam.
	Lack of foam	Check if the Foam Pump is on. Check if there is foam in the reservoir. Make sure the foam supply valve is on and the Y strainer clean.
Foam in water system	Foam dumped into the water tank	Flush water tank and pump until foam is cleared.
	Foam cell is leaking into water tank	Condition applies to tanks utilizing a common wall(s) between the foam tank and the water tank. If a leak is confirmed, repair the foam tank and flush the water tank and pump until foam is cleared.
	Foam proportioning manifold check valve malfunction	If the above conditions have been corrected, the final cause for foam in the water tank may be the result of a malfunctioning foam manifold check valve. To troubleshoot, cap off one foam discharge that is plumbed to the foam manifold, open that discharge valve and increase the pump discharge to 30–40 PSI. Disengage the pump and monitor the corresponding discharge PSI gauge, looking for a drop in discharge pressure. If the PSI drops, it indicates the foam manifold check valve is leaking and requires repair.
	Foam manifold drain plumbed into master drain	Supply a separate drain for foam manifold.