

Revised:08/26/11



WATEROUS COMPANY

SOUTH ST. PAUL, MINNESOTA

SERVICE PARTS LIST

Plate(s) Revised: 5/90

Electric Shift Assembly

REF NO.	DESCRIPTION	REF NO.	DESCRIPTION
F1	Wiring harness	F62	Pivot plate
F2	Switch-to-circuit-breaker wire	F63	Shift arm assembly
F3	Circuit-breaker-to-ignition-switch wire	F64	Shift actuating lever
F4	Shift plate	F65	Shift shaft
F5	Shift control switch, w/3 terminals (SPDT)	F66	Socket hd cap screw, 1/4-20 x 5/8 in.
F5	Shift control switch, w/6 terminals (DPDT)	F67	Cotter pin, SS, 3/32 x 1/2 in.
F6	Switch guard	F68	Dowel pin, 1/4 x 5/8 in.
F7	Circuit breaker	F69	Actuating cam pin
F8	Hex nut, No. 8-32	F70	Spirol pin, SS 1/4 x 1-1/4 in.
F9	Hex nut, No. 10-32	F71	Self-locking cap screw, 1/4-20 x 1 in.
F10	Rd hd screw, SS, No. 8-32 x 3/8 in.	F72	Lock washer, 1/4 in.
F11	Lock washer, No. 8	F75	Pivot plate cover
F12	Lock washer, No. 10	F76	Gasket (Used after 8/16/65)
F13	Wire clamp	F77	Shift shaft bushing (Used from 8/16/65 to 5/14/80)
F14	Shift unit	F78	O-ring packing (Used after 8/16/65)
F19	Mounting bracket subassembly (includes F78, F114 & F125)	F93	Switch bracket
F30	Lock washer, 7/16 in.	F94	Switch, indicating light
F40	Cap screw, self-locking (Nylok), 7/16-14 x 1 in.	F95	Switch seal
F57	Shift shaft bushing (Not shown: replaced by F77 and F78 starting 8/16/65.)	F96	Wire assembly
F58	Gasket (Not shown; replaced by F76 after 8/16/65)	F97	Wire harness
F59	Shift shaft spring	F98	Flasher terminal block
F60	Actuating cam	F99	Flasher
F61	Bearing washer	F100	Wire assembly
		F101	Wire assembly
		F102	Indicating light, green lens

PLEASE NOTE

WHEN ORDERING PARTS PLEASE SUPPLY PUMP SERIAL NUMBER

W A T E R O U S

Electric Shift Assembly

REF NO.	DESCRIPTION	REF NO.	DESCRIPTION
			<u>REPAIR PARTS</u>
F103	Indicating light, red lens		
F105	Panel Plate, indicating light		
F106	Wire assembly	F49	Shift-unit motor, 12-volt (Eaton #40635) (No longer available from Waterous)
F107	Wire assembly	F50	Limit switch assembly, shift unit (Eaton #113610)
F108	Cover plate	F51	Motor support and cover gasket (Eaton #40639)
F109	Switch cover	F52	Shift housing cover gasket (Eaton #32414)
F110	Grommet	F53	Bearing cover gasket (Eaton #32404)
F111	Hex nut, 1/4-20	F54	Ball bearing (Eaton #32401, ND #47500LIC)
F113	Rd hd screw, 1/4-20 x 5/8 in.	F55	Drive nut contact bumper (Eaton #32369) (No Longer Available From Waterous)
F114	Sleeve Bearing (Used after 5-14-80, bronze color)	F73	Terminal bushing (Eaton #52504)
F118	Motor and Bracket Assembly	F74	Terminal insulator (Eaton #38315)
F125	Sleeve Bearing (Used after 4/12/90, silver color)	F104	Bulb, 12 volt #1891 (not shown) for F102 and F103 indicating lights.

NOT FURNISHED BY WATEROUS
AFTER 5-15-68

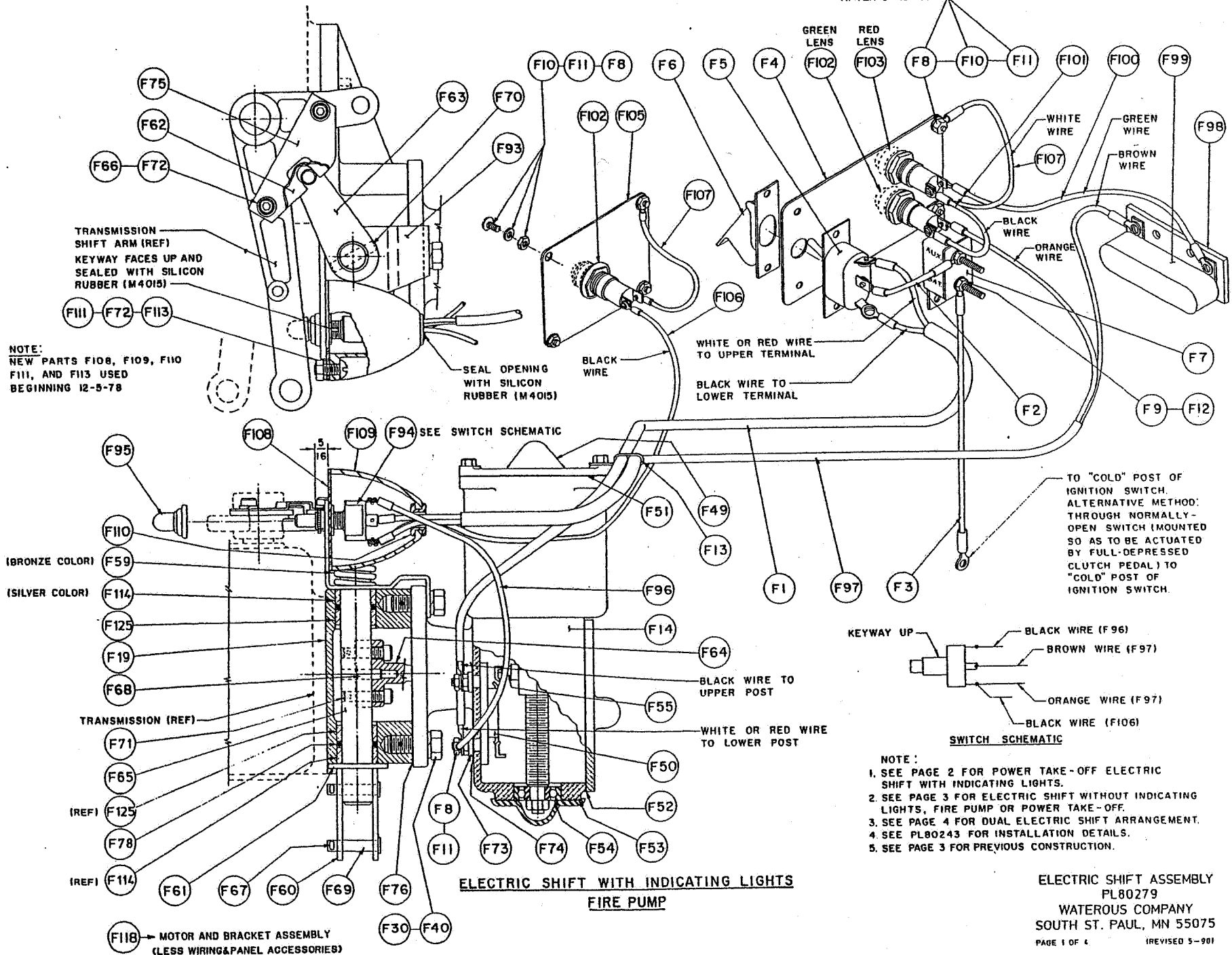

ELECTRIC SHIFT ASSEMBLY
PL80279
WATEROUS COMPANY
SOUTH ST. PAUL, MN 55075
PAGE 1 OF 4 REVISED 5-901

NOT FURNISHED BY WATEROUS
AFTER 5-15-68

NOTE:
NEW PARTS F108, F109, F110,
F111, AND F113 USED
BEGINNING 12-5-78

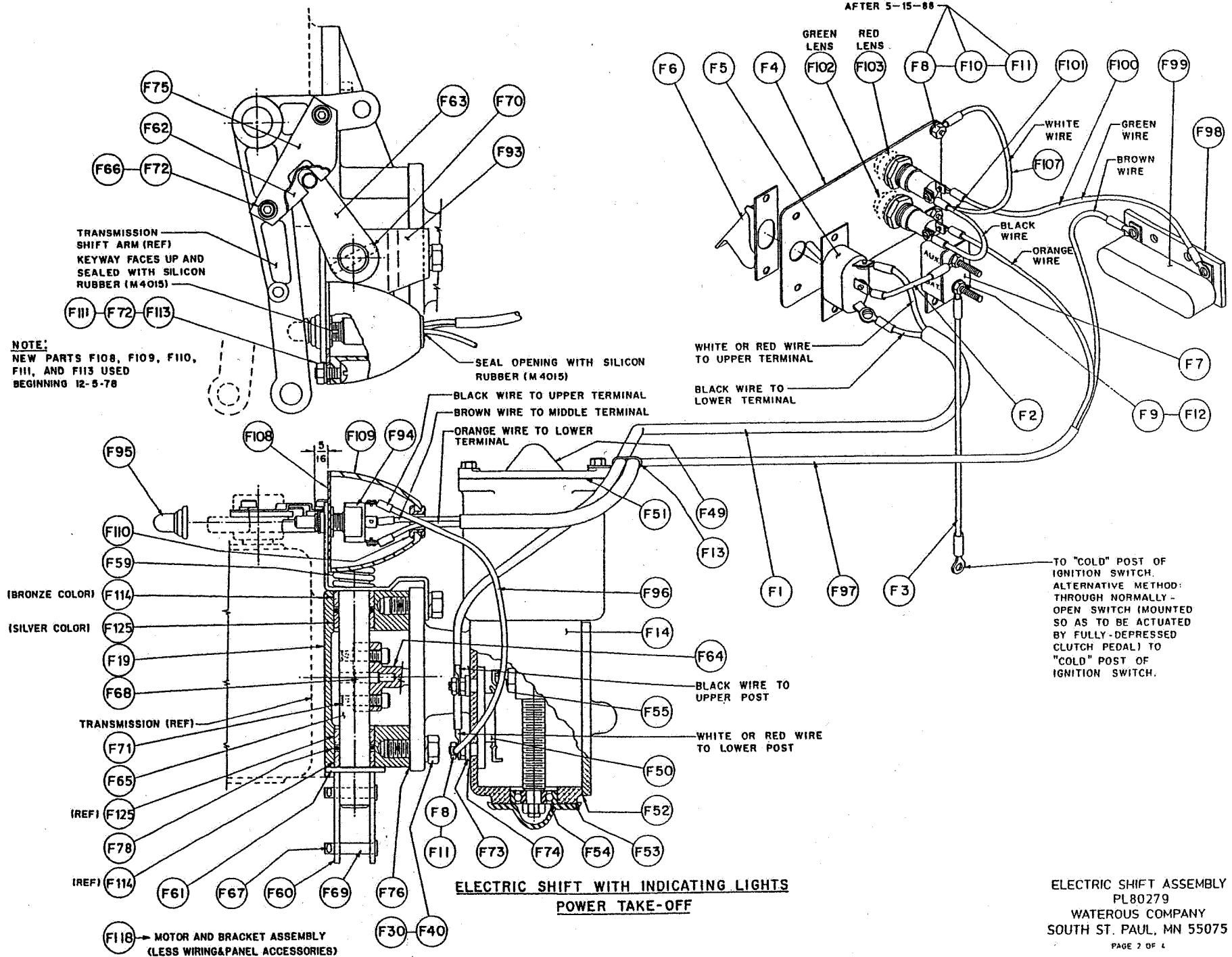

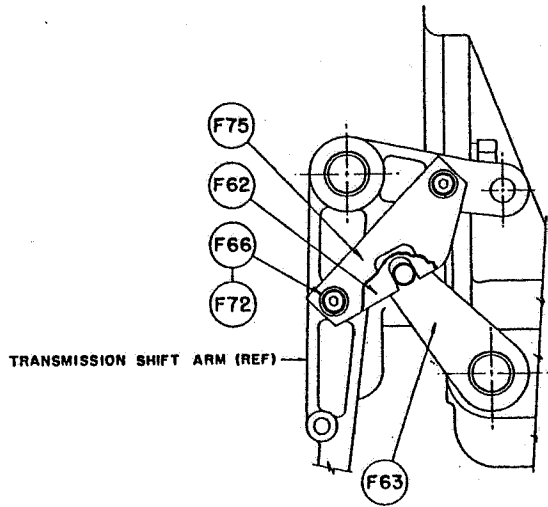

TRANSMISSION SHIFT ARM (REF)

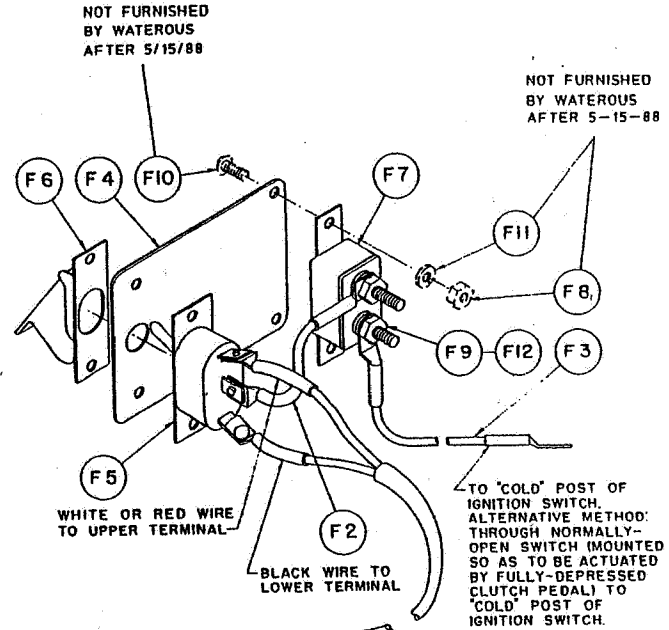

NOT FURNISHED BY WATEROUS AFTER 5/15/88

NOT FURNISHED BY WATEROUS AFTER 5-15-88

TO "COLD" POST OF IGNITION SWITCH. ALTERNATIVE METHOD: THROUGH NORMALLY-OPEN SWITCH (MOUNTED SO AS TO BE ACTUATED BY FULLY-DEPRESSED CLUTCH PEDAL) TO "COLD" POST OF IGNITION SWITCH.

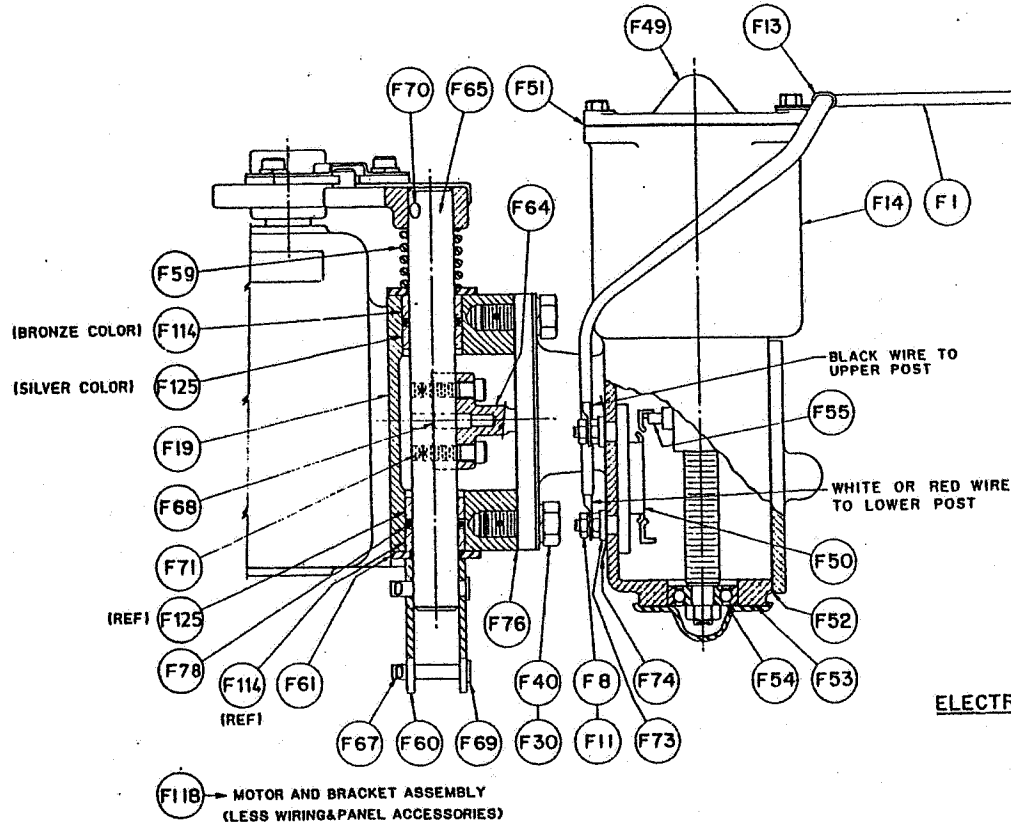

(BRONZE COLOR)

(SILVER COLOR)

(REF)

F118 - MOTOR AND BRACKET ASSEMBLY (LESS WIRING & PANEL ACCESSORIES)

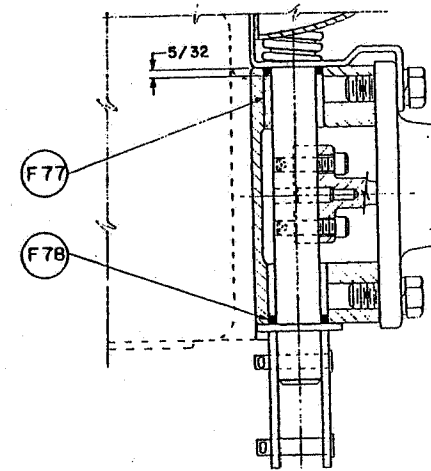

CONSTRUCTION PRIOR TO 5-14-80

NOTE: SEE PL80243 FOR INSTALLATION DETAILS.

**ELECTRIC SHIFT WITHOUT INDICATING LIGHTS
FIRE PUMP OR POWER TAKE - OFF**

ELECTRIC SHIFT ASSEMBLY
PL80279
WATEROUS COMPANY
SOUTH ST. PAUL, MN 55075

NOT FURNISHED BY WATEROUS
AFTER 5-15-88

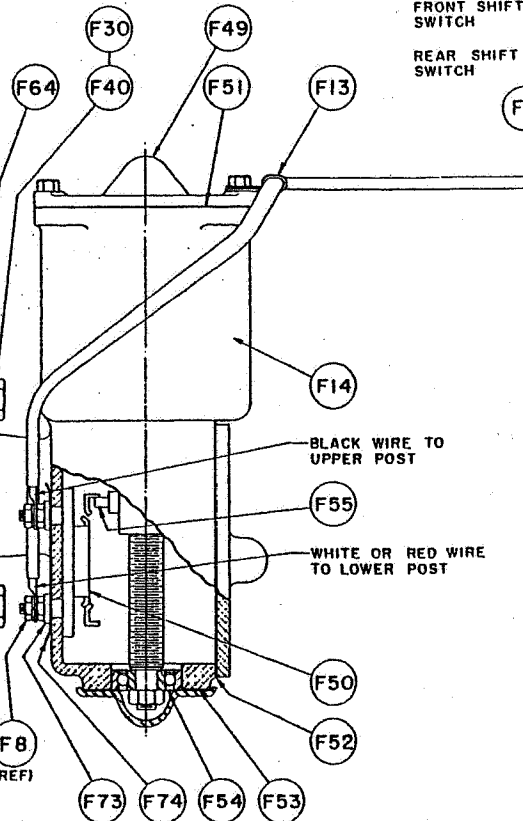
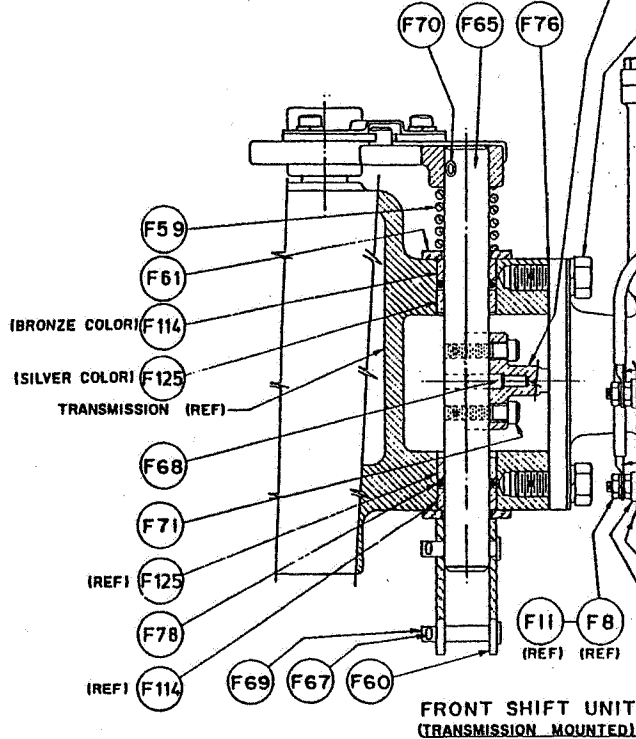
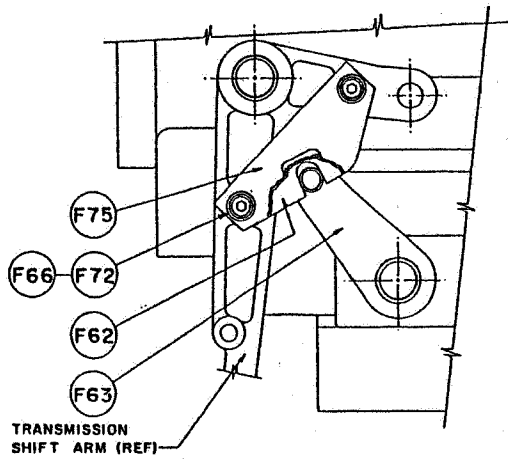

**DUAL ELECTRIC SHIFT
FIRE PUMP**

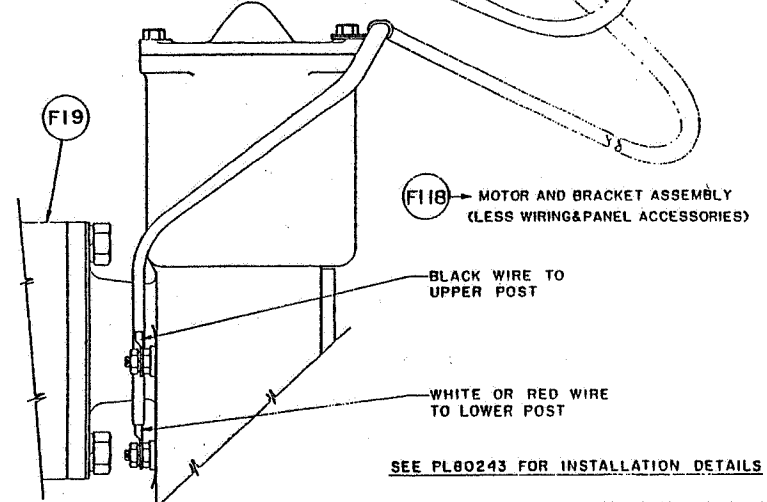
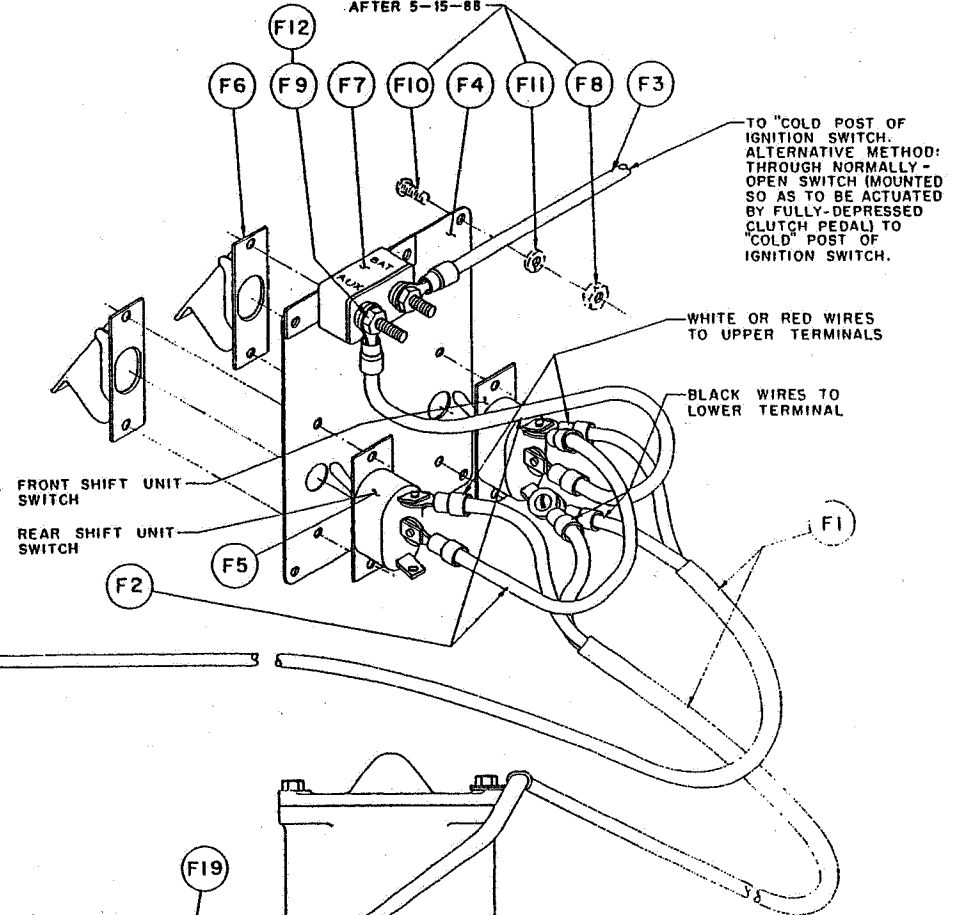

**REAR SHIFT UNIT
(BRACKET MOUNTED)
(SEE PAGE 1 FOR DETAILS)**

SEE PL80243 FOR INSTALLATION DETAILS

ELECTRIC SHIFT ASSEMBLY
PL80279
WATEROUS COMPANY
SOUTH ST. PAUL, MN 55075