

Issued: 5/68

Revised: 2/94

## FLOTO PUMP, STANDARD

REF NO.	DESCRIPTION	REF NO.	DESCRIPTION
<b>PUMP REPAIR PARTS</b>			
1	Air intake stack cover	22	Lower volute
2	Wing nut, no. 10-32	23	Throttle control float assembly
3	Lock washer, internal tooth No. 10	25	Throttle control arm
4	Plain washer, air filter cover	26	Fuel line
6	Lifting handle	27	Carburetor spacer
7	Engine	28	Socket hd cap screw, no. 10-32 x 1-1/2 in. or socket hd cap screw, no. 10-32 x 3/8 in. w/drilled head
7A	See ref no. 131	29	Socket hd cap screw, 1/4-20 x 2-1/2 or 2-5/8 in.
7B	Air filter element	30	Fuel tank strap
7C	Air filter lid	31	Filler cap
7D	Air filter base	32	Fuel tank
7E	Air filter clip	33	Self tapping rnd hd screw, no. 12 x 1/2 in.
8	Float, includes ref no. 51, 79 and 134	34	Rnd hd mach screw, zinc pld, no. 10-24 x 1 in.
11	Skid	36	Pipe nipple, 1-1/2 NPT x 8-7/8 in. (Used only w/nozzle 37)
12	Spacer stud	36	Pipe nipple, 1-1/2 NPSH x 11 in.
13	Self-locking nut, 3/8-16	37	Discharge nozzle (Used only with 8-7/8 in. nipple 36)
14	Plain washer, 3/8 in.	38	Hex hd screw, 3/8-16 x 1-1/4 in.
15	Suction screen	41	Fuel line filter
16A	See ref no. 132	42	Lock washer, internal tooth, 1/4 in.
16B	See ref no. 132	43	Pipe nipple, 1-1/4 NPT x 4 in.
17	Self-locking nut, 9/16-18	44	Muffler
18	Impeller	45	Exhaust adapter
19	Dowel pin, SS, 5/16 x 3/4 in.	46	O-ring, 7-1/4 x 7-1/2 in.
20	Upper volute		
21	Socket hd cap screw, 5/16-18 x 1-1/2 in.		

## PLEASE NOTE

WHEN ORDERING PARTS PLEASE SUPPLY PUMP SERIAL NUMBER

PL80614

Page 1 of 4

## FLOTO PUMP, STANDARD

REF NO.	DESCRIPTION	REF NO.	DESCRIPTION
47	Grommet	66	Safety wire
48	Choke decal	78	Muffler bracket shim
49	RUN-STOP decal	79	Patent decal
50	Fuel mix decal	80	Folding spanner wrench
51	Name plate decal (includes pump serial number)	83	Hex hd screw, 5/16-18 x 1-1/4 in.
52	Exhaust adapter brace	84	Lock plate
53	U-bolt clamp	132	Mechanical seal (formerly ref no. 16A, 16B and 133)
54	Cap screw, hex hd, self-locking, 1/4-20 x 1 in.	133	See ref no. 132
55	Lock washer, 1/4 in.	134	Warning label
58	Self-locking nut, 1/4-20	163	Fuel line replacement kit, includes ref no. 26 & 47
65	Air intake stack		

## ENGINE REPAIR PARTS

35	Self-locking nut, no. 10-24	82	Muffler bracket
56	Complete carburetor	85	Cylinder cover
57	Carburetor gasket	86	Fan housing
69	Manifold gasket	87	Support plate
70	Transfer port cover gasket	88	Coil wedge spring
71	Carburetor stud	89	Coil with sparkie
72	Breaker point set	90	Fuel tank assembly, includes ref no. 31, 32, 41 and 50
73	Condenser	91	Ignition switch
74	Spark plug (Champion L-86C) or (AC R447)	92	Air intake conversion kit, includes ref no, 1, 2, 4, 28, 65 and 66
75	Carburetor adapter elbow	93	Starter replacement kit
76	Manifold	94	Carburetor repair parts kit
81	Head bolt stud	95	Flywheel key

## FLOTO PUMP, STANDARD

REF NO.	DESCRIPTION	REF NO.	DESCRIPTION
96	Stator plate cover	121	Crankpin roller set
97	Cover gasket	123	Pan hd screw with lockwasher, 1/4-20 x 3/4 in.
98	Magneto end seal	124	Pan hd screw with lockwasher, 1/4-20 x 7/8 in.
99	Stator plate	125	Hex hd screw with lockwasher, 1/4-20 x 1-1/8 in.
100	Cam felt	126	Hex hd screw with lockwasher, 1/4-20 x 3/8 in.
101	Fuel strainer cover	127	Pan hd screw with lockwasher, 1/4-20 x 5/8 in.
102	Main adjustment screw washer	128	Pan hd screw with lockwasher, 1/4-20 x 1/2 in.
103	Throttle shaft and lever	130	Hex nut, 1/4-20
104	Bearing cage gasket	131	Woodruff key (formerly ref no. 7A)
105	Ball bearing	135	Rnd hd screw with washer, 1/4-20 x 5/8 in.
106	Crankshaft	136	Hex nut, 7/16-20
107	Connecting rod with cap	137	Lockwasher, 7/16 in.
108	Retaining ring	138	Starter cup
109	Piston	139	Flywheel
110	Piston pin	140	Cam
111	Piston ring set	141	Ground lead
112	Cylinder head	142	Hex slot screw with lockwasher, 1/4-20 x 11/16 in.
113	Head gasket, .032 in. thick	143	Cover spring
114	Head gasket, .062 in. thick	144	Insulator
115	Cylinder w/seal	145	Pan hd screw with plain washer, no. 8-32 x 5/16 in.
116	Reed	146	Pan hd screw with lockwasher, no. 8-32 x 5/16 in.
117	Drive end seal	147	Condenser clamp
118	Crankcase cover gasket	148	Plain washer, 1/4 in.
119	Transfer port cover	149	Crankcase cover
120	Connecting rod screw	150	Reed stop
		151	Rnd hd screw with lockwasher, no. 6-32 x 5/16 in.

---

**FLOTO PUMP, STANDARD**

---

REF NO.	DESCRIPTION	REF NO.	DESCRIPTION
152	Reed plate (includes 116, 150 & 151)	160	Fuel strainer screen
153	Spring lockwasher, 1/4 in.	161	Fuel strainer cover gasket
154	Socket hd cap screw, 1/4-20 x 11/16	162	Pan hd screw, no. 6-32 x 7/16
155	Plain washer, 1/4 in.	167	Atom module assembly
156	Pan hd screw, no. 6-32 x 3/8 in.	170	Fillister hd screw, no. 10-24 x 9/16 in.
157	Stud or insulator screw, no. 6-32 x 5/8 in.	171	Power head gasket and seal repair kit
158	Lockwasher, no. 6	172	Plain washer, 1/4 in.
159	Hex nut or self-locking nut, no. 6-32		

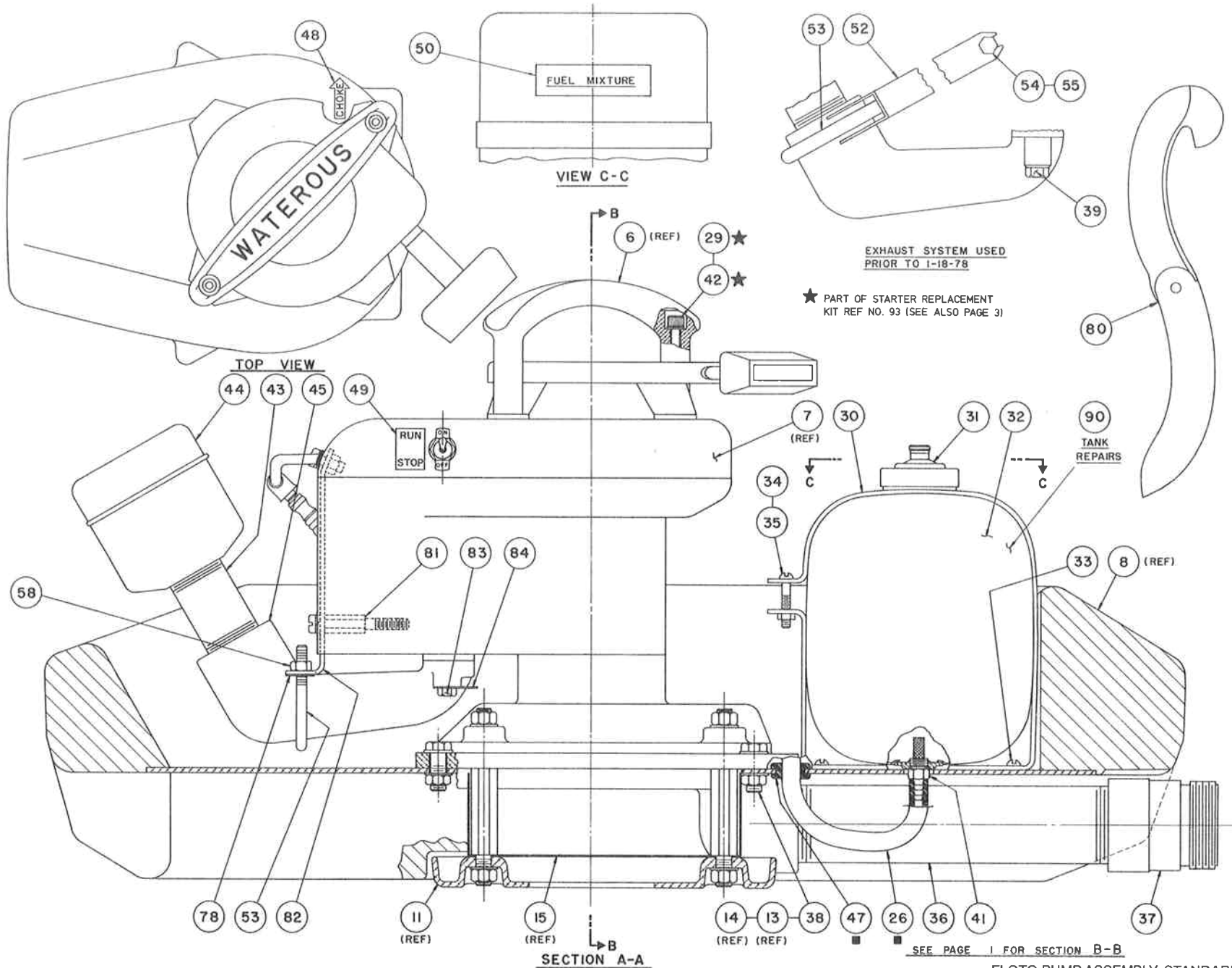

EXHAUST SYSTEM USED  
PRIOR TO 1-18-78

★ PART OF STARTER REPLACEMENT  
KIT REF NO. 93 (SEE ALSO PAGE 3)

90  
TANK  
REPAIRS

SEE PAGE 1 FOR SECTION B-B

■ PART OF FUEL LINE KIT REF NO. 163

FLOTO PUMP ASSEMBLY, STANDARD

PL 80614

WATEROUS COMPANY

SOUTH ST. PAUL, MN 55075

PAGE 2 OF 5

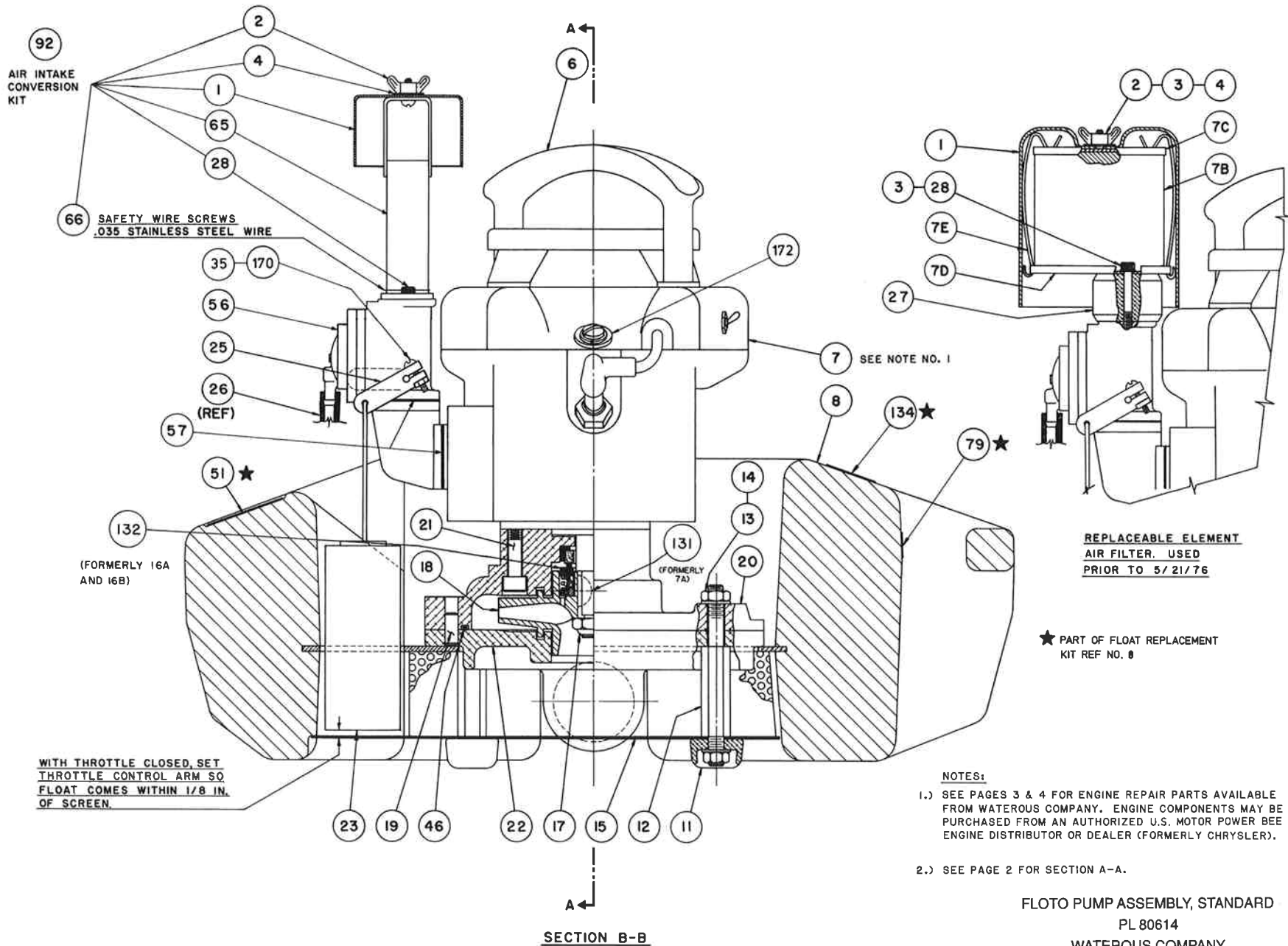

**REPLACEABLE ELEMENT  
AIR FILTER. USED  
PRIOR TO 5/21/76**

★ PART OF FLOAT REPLACEMENT  
KIT REF NO. 8

**NOTES:**

- 1.) SEE PAGES 3 & 4 FOR ENGINE REPAIR PARTS AVAILABLE FROM WATEROUS COMPANY. ENGINE COMPONENTS MAY BE PURCHASED FROM AN AUTHORIZED U.S. MOTOR POWER BEE ENGINE DISTRIBUTOR OR DEALER (FORMERLY CHRYSLER).
- 2.) SEE PAGE 2 FOR SECTION A-A.

**FLOTO PUMP ASSEMBLY, STANDARD  
PL 80614  
WATEROUS COMPANY  
SOUTH ST. PAUL, MN 55075**

(ISSUED 4-68) PAGE 1 OF 5 (REVISED 2-94)

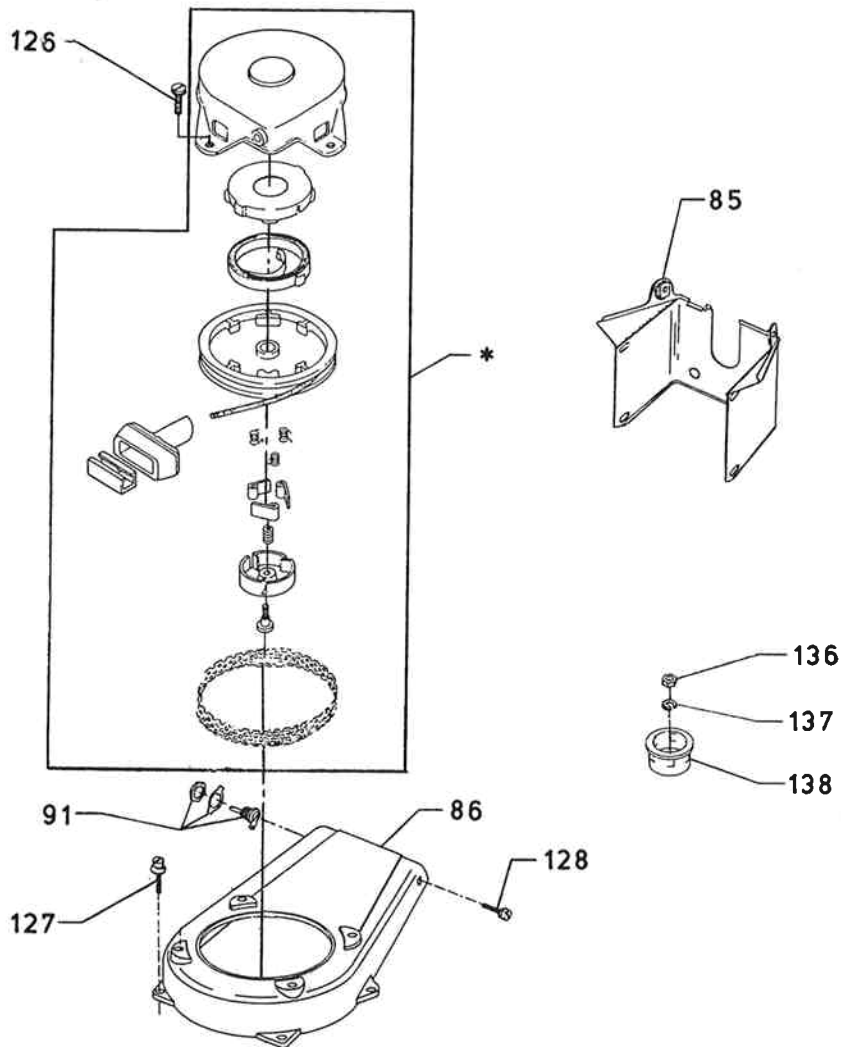

\* INCLUDED IN STARTER REPLACEMENT KIT REF NO. 93

(ALSO SEE PAGES 2 AND 4)

**STARTER (USED PRIOR TO 6/24/93)**

**NOTE:** ENGINE PARTS DESIGNATED BY A REF NO. CAN BE SUPPLIED BY WATEROUS COMPANY OR A U.S. MOTOR POWER BEE DISTRIBUTOR OR DEALER. PARTS WITHOUT A REF NO. CAN BE SUPPLIED BY U.S. MOTOR POWER ONLY. SEE U.S. MOTOR POWER'S, OR CHRYSLER'S SERVICE MANUAL FOR INFORMATION ON OBTAINING THESE PARTS.

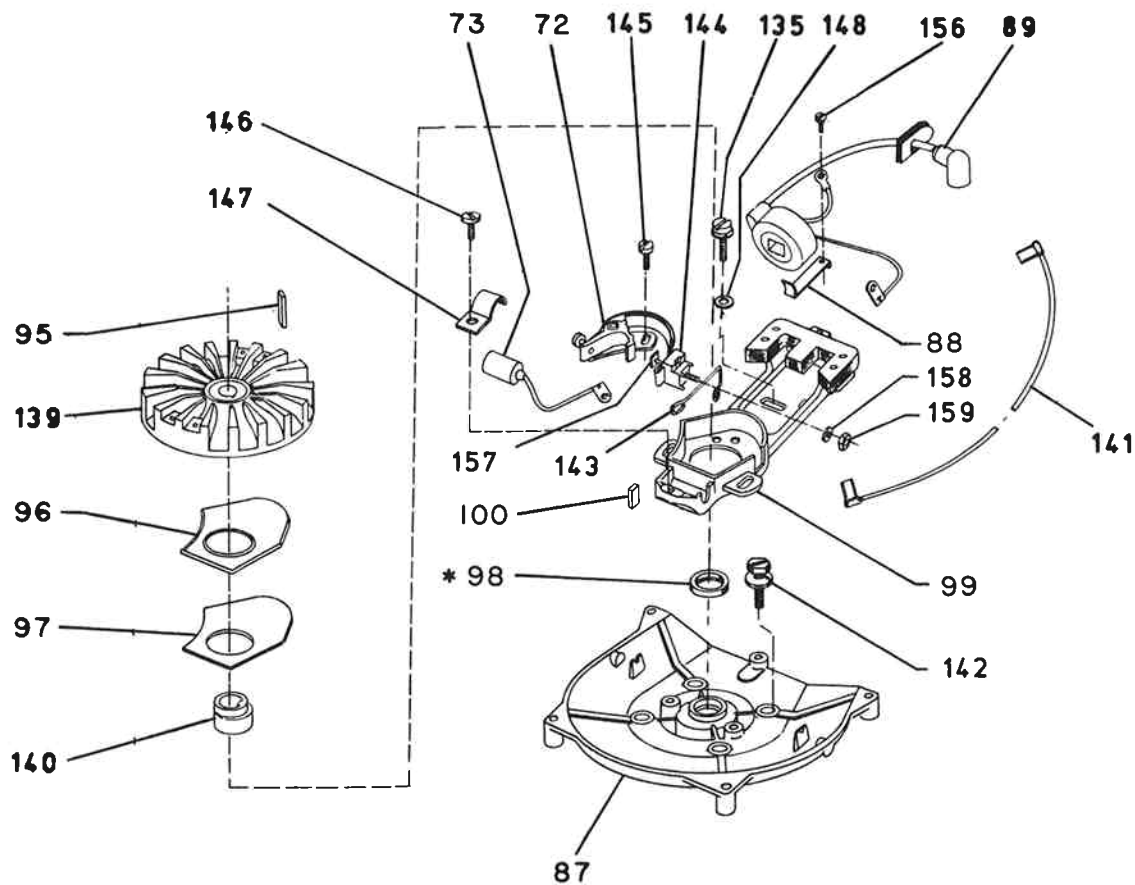

(ALSO SEE PAGE 4)

**MAGNETO (USED PRIOR TO 12/5/93)**

\* INCLUDED IN GASKET REPAIR KIT REF. NO. 171 (SEE PAGE 5)

FLOTO PUMP ASSEMBLY, STANDARD

PL 80614

WATEROUS COMPANY

SOUTH ST. PAUL, MN 55075

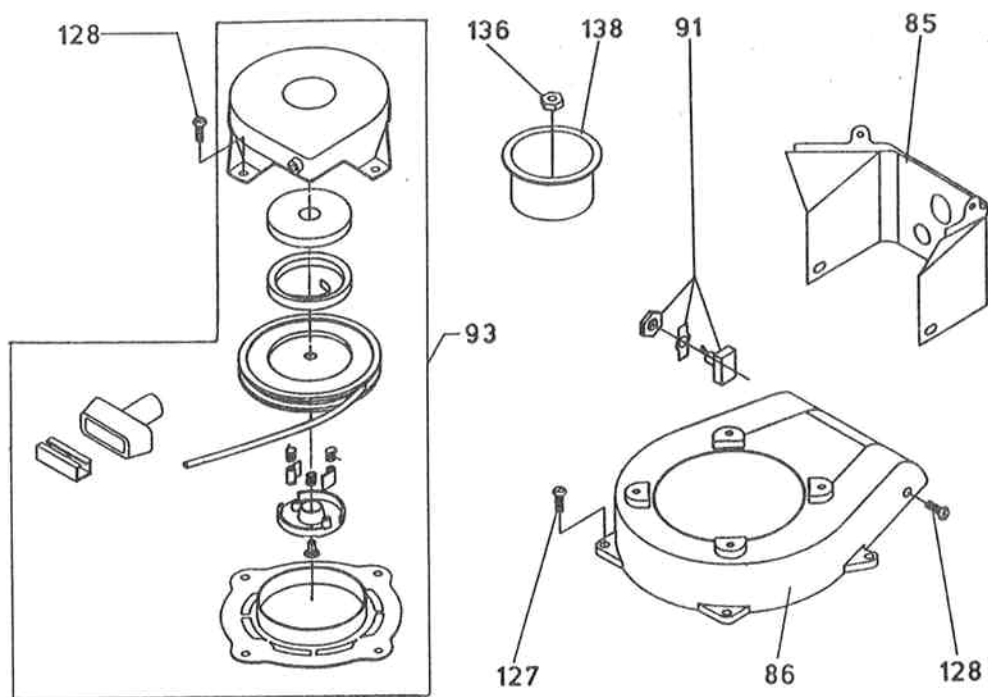

(ALSO SEE PAGES 2 AND 3)

**STARTER (USED AFTER 6/24/93)**

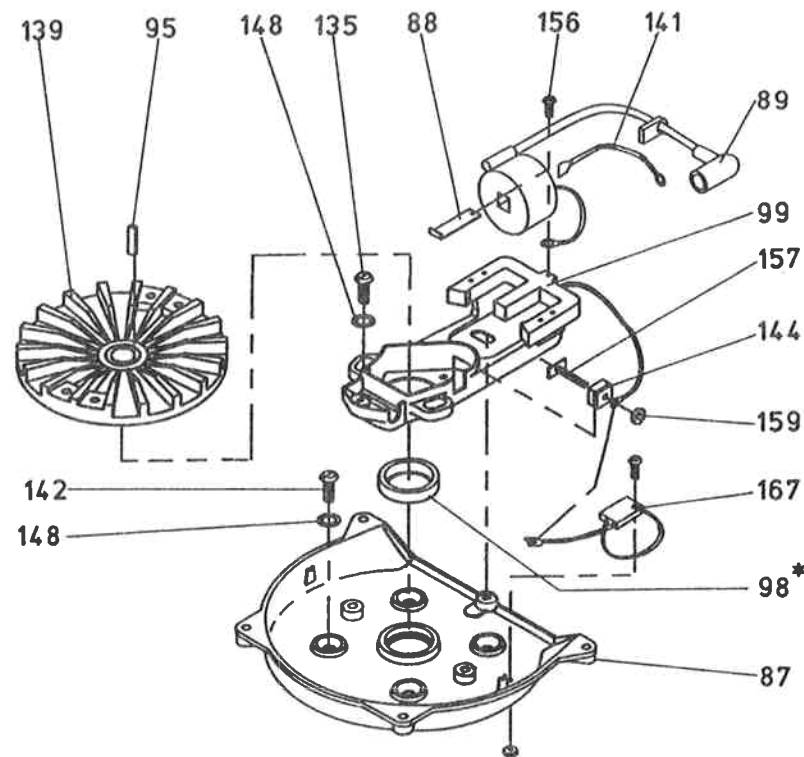

**IGNITION (USED AFTER 12/5/93)**

\* INCLUDED IN GASKET REPAIR KIT REF NO. 171 (SEE PAGE 5)

(ALSO SEE PAGE 3)

**NOTE:**

ENGINE PARTS DESIGNATED BY A REF. NO. CAN BE SUPPLIED BY WATEROUS COMPANY OR A U.S. MOTOR POWER BEE DISTRIBUTOR OR DEALER. PARTS WITHOUT A REF. NO. CAN BE SUPPLIED BY U.S. MOTOR POWER ONLY. SEE U.S. POWER'S, OR CHRYSLER'S SERVICE MANUAL FOR INFORMATION ON OBTAINING THESE PARTS.

FLOTO PUMP ASSEMBLY, STANDARD  
 PL 80614  
 WATEROUS COMPANY  
 SOUTH ST. PAUL, MN 55075



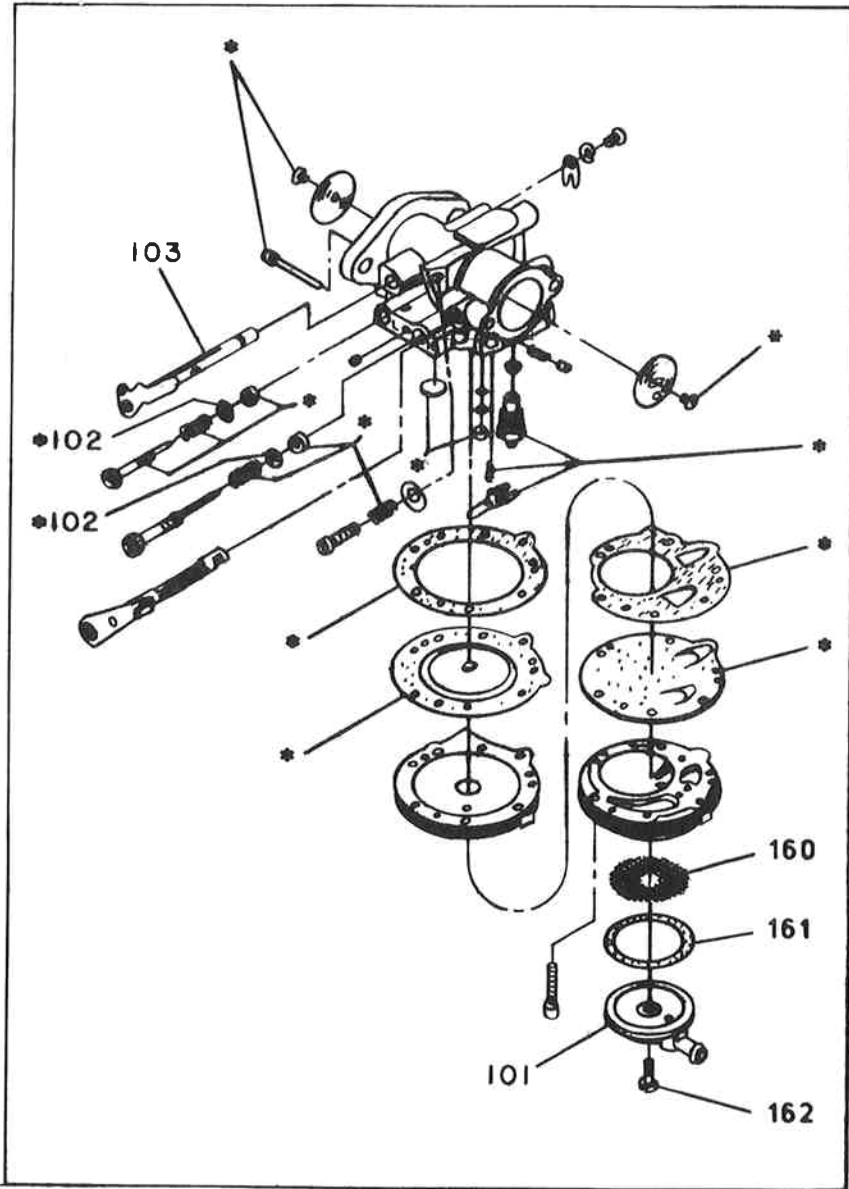

\* INCLUDED IN CARBURETOR REPAIR KIT REF NO. 94

**CARBURETOR  
KIT**

**CARBURETOR**

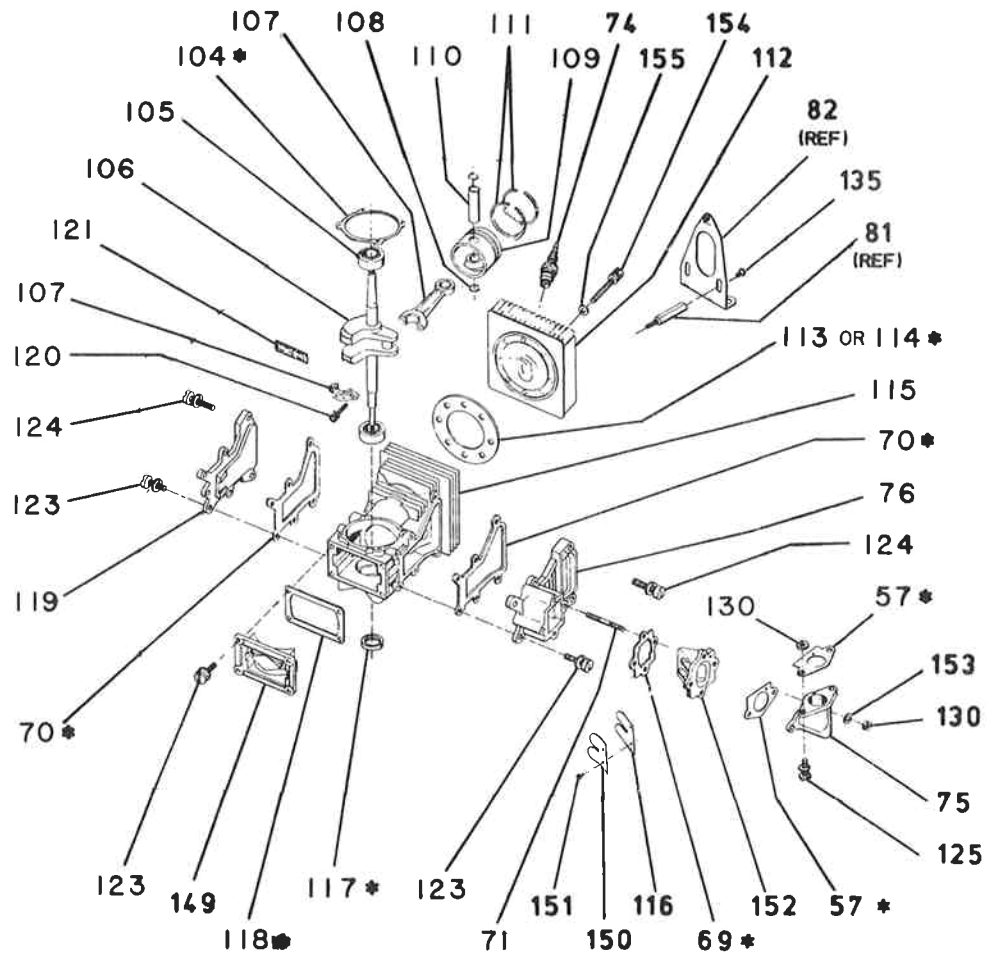

56 COMPLETE CARBURETOR  
(INCLUDES (I) REF NO. 57,  
SEE POWER HEAD DETAIL)

INCLUDED IN GASKET REPAIR KIT REF. NO. 171

**GASKET  
KIT**

**POWER HEAD**

FLOTO PUMP ASSEMBLY, STANDARD  
PL 80614  
WATEROUS COMPANY  
SOUTH ST. PAUL, MN 55075