

Issued: 06/09/71

Revised: 11/02/07

WATEROUS

WATEROUS

SOUTH ST. PAUL, MINNESOTA

3 Inch Indicating Relief Valve

REF NO.	DESCRIPTION	REF NO.	DESCRIPTION
V2	Drain cock, 1/4 in. (used prior to 12/20/89)	V31	Wire assembly (used prior to 4/21/06)
V4	Valve spring	V33	Switch ground wire assembly (used prior to 6/1/86)
V5	Main valve	V34	Indicator light panel plate (used prior to 2/25/91) (Furnished as part of pilot valve after 2/25/91)
V6	Cover gasket	V35	Wiring harness (used prior to 4/21/06)
V7	Valve cover	V36	Indicator light, green lens (closed) (used prior to 4/21/06)
V8	Valve body	V37	Indicator light, amber lens (open) (used prior to 4/21/06)
V9	Cap screw, 3/8-16 x 1 in.	V38	Light bulb (12 volt - light No. 1891) (24 volt - light No. 313) (used prior to 4/21/06)
V10	O-ring	V39	Actuator switch (used prior to 4/21/06)
V11	Sq hd pipe plug, 1/4 in. (used prior to 6/1/86) or socket hd pipe plug, 1/4 in. (used prior to 7/15/96)	V40	Connecting and sealing device (used prior to 6/1/86)
V21	Switch actuating rod	V40	Sealing grip, straight or 90° elbow (used from 6/1/86 to 4/21/06)
V22	Actuating rod spring	V41	Hex nut, No. 8-32 (not furnished by Waterous after 5/15/88)
V24	Switch mounting bracket	V42	Rd hd screw, SS, No. 8-32 x 3/8 in. (not furnished by Waterous after 5/15/88)
V25	O-ring	V43	Lock washer, No. 8 (not furnished by Waterous after 5/15/88)
V26	Plain copper washer, 3/8 in.	V52	O-ring
V27	Groove pin, SS, 1/8 x 5/8 in.	V59	Complete replacement valve without wiring assembly
V28	Flared coupling nut, 3/4 in.	V60	Repair kit (consists of V6, V10, V25, V27 & V52)
V29	Half union elbow, 1/4 pipe to 3/8 tube	V61	Compression fitting, 3/8 x 1/4 in.
V30	Wiring assembly (includes items V31 through V43 prior to 4/21/06) Not included with dual relief valve, see relief valve and piping assembly		

PLEASE NOTE

WHEN ORDERING PARTS PLEASE SUPPLY PUMP SERIAL NUMBER

SPL80746

PAGE 1 OF 4

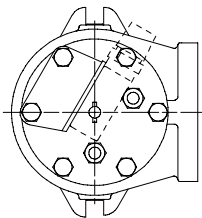

RIGHT FACING & RIGHT MOUNTING
DISCHARGE ASSEMBLIES

- 80746-1 (12V)
- 80746-1D (W/O WIRING)
- 80746-5 (24V)
- 80746-7 (12V OR 24V)

EFFECTIVE 01/17/97: WIRING TO
POINT UPWARD ONLY FOR R.H.
MOUNTING CONFIGURATIONS.

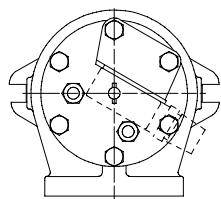

DOWN FACING DISCHARGE ASSEMBLIES

- 80746-2 (12V, LEFT SIDE MOUNTING)
- 80746-2L (12V, RIGHT SIDE MOUNTING)
- 80746-3 (W/O WIRING, EITHER SIDE MOUNTING)
- 80746-8 (12V OR 24V, LEFT SIDE MOUNTING)
- 80746-9 (12V OR 24V, RIGHT SIDE MOUNTING)

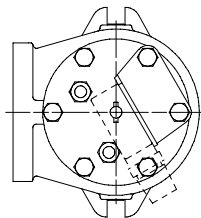

LEFT FACING & LEFT MOUNTING
DISCHARGE ASSEMBLIES

- 80746 (12V)
- 80746-4 (24V)
- 80746-6 (12V OR 24V)
- 80746-D (W/O WIRING)

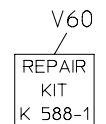
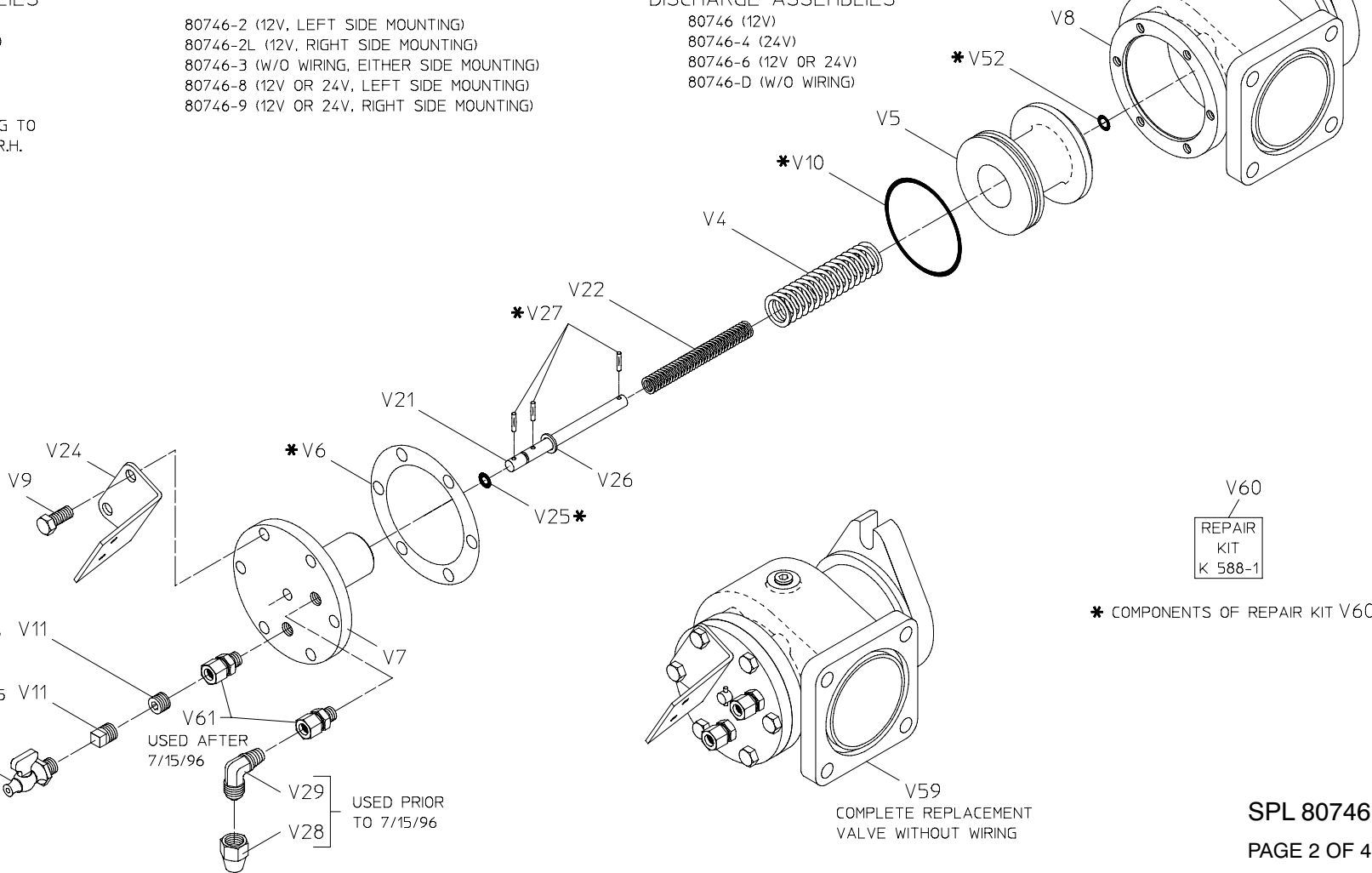
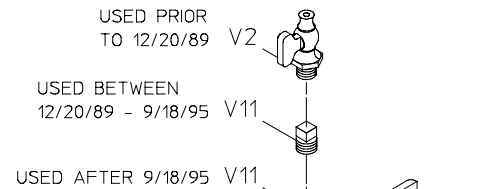

* COMPONENTS OF REPAIR KIT V60

USED BETWEEN 9/18/95 - 7/15/96 V11

USED BETWEEN 12/20/89 - 9/18/95 V11

USED PRIOR TO 12/20/89 V2

USED AFTER 7/15/96

USED PRIOR TO 7/15/96

SPL 80746

PAGE 2 OF 4

REV: 11/02/07

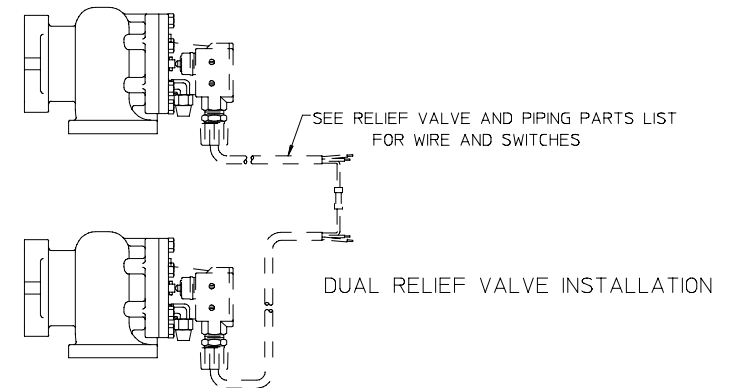
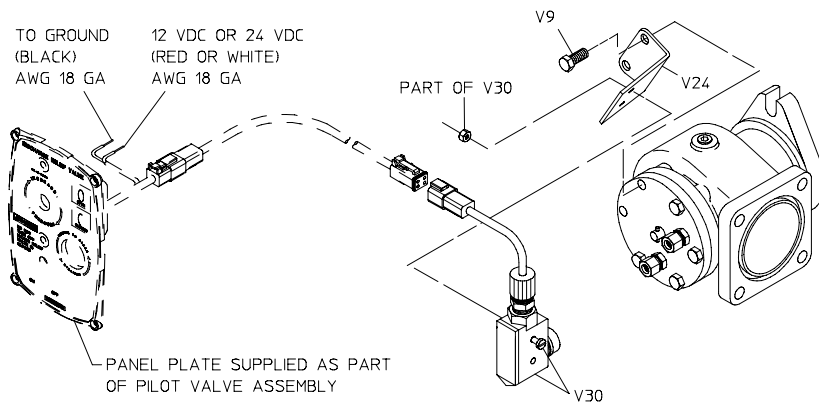
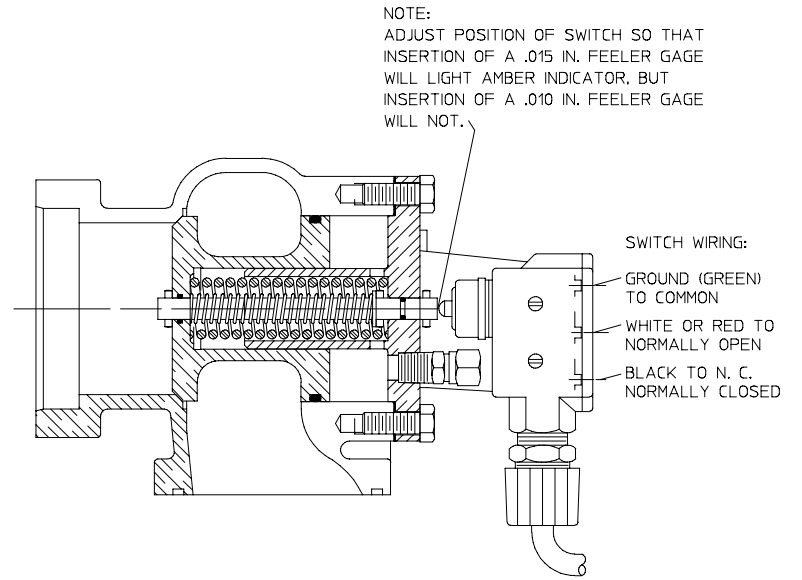
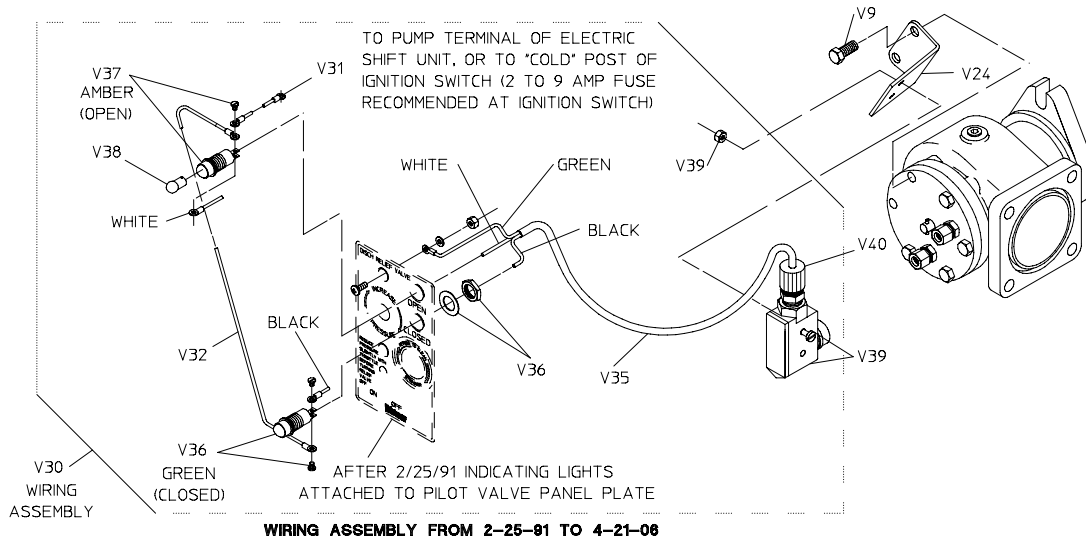

WIRING DETAILS

