

Issued: 4/91

Revised: 8/28/18

W A T E R O U S

WATEROUS COMPANY

SOUTH ST. PAUL, MINNESOTA

2-1/2 Full Flow Discharge Valve Assembly

REF NO.	DESCRIPTION	REF NO.	DESCRIPTION
GV8	Seal spring or wave spring	GV46	O-ring packing
GV9	Seal	GV47	O-ring packing
GV15	Upper stem bushing	GV49	O-ring packing
GV16	Lower stem bushing	GV50	Lock washer, 5/16 in.
GV17	Rack locking plate	GV52	Spirol pin, SS, 1/4 x 1-1/4 in.
GV20	Universal joint	GV53	Roll pin, SS, 1/4 x 1-1/8 in.
GV24	Mounting flange	GV54	Sq socket pipe plug, 3/4 in.
GV27	Roll pin, SS, 1/4 x 11/16 in. (See note on page 2)	GV56	Cap screw, zinc plated, 3/8-16 x 3/4 in. for cast bracket; 3/8-16 x 9/16 in. or 5/8 in. for stamped bracket
GV28	Tapped flange (In-line valve)	GV57	Round hd machine screw, no. 8-32 x 3/8 in. (not furnished by Waterous after 5/15/88)
GV31	Valve body subassembly (includes GV16)	GV59	Lock washer, no. 8 (not furnished by Waterous after 5/15/88)
GV32	Seal retainer	GV60	Hose adapter (See note on page 2)
GV33	Rack bearing (part of GV85)	GV64	Pipe nipple, 2-1/2 x 10 in. (See note on page 2)
GV35	Cap screw, zinc pld, 5/16-18 x 1/2 in.	GV66	Hose nipple (See note on page 2)
GV36	Flat socket hd cap screw, zinc pld, 7/16-14 x 3/4 in.	GV72	Panel plate (See note on page 2)
GV37	Hex hd bolt, 7/16-20 x 1-1/2 in.	GV74	Hex socket pipe plug, 1/4 in.
GV37	Cap screw, 7/16-14 x 1 in. (used instead of bolt GV37 when discharge flange has tapped mounting holes)	GV75	Universal joint bushing
GV38	Hex nut, 7/16-20 (used with bolt GV37)	GV76	Control rod, panel side (See note on page 2)
GV40	Hex nut, no. 8-32 (not furnished by Waterous after 5/15/88)	GV77	Control rod, remove side (See note on page 2)
GV42	O-ring packing	GV80	Control handle (See note on page 2)
GV43	O-ring packing	GV81	Rubber washer or snap bushing (used until 2/25/91) (See note on page 2)
GV45	O-ring packing		

PLEASE NOTE

WHEN ORDERING PARTS PLEASE SUPPLY PUMP SERIAL NUMBER

SPL80824

PAGE 1 OF 5

W A T E R O U S

WATEROUS COMPANY

SOUTH ST. PAUL, MINNESOTA

2-1/2 Full Flow Discharge Valve Assembly

REF NO.	DESCRIPTION	REF NO.	DESCRIPTION	
GV82	Rack		Note: This part may have been furnished by either Waterous Company or original equipment manufacturer.	
GV83	Gear sector assembly			
GV84	Valve ball			
GV85	Bracket subassembly (Stamped steel-includes GV33 & GV98. Used after 5/8/89). (Casting-includes GV33. No longer used after 5/8/89).	GV98		Retaining ring (part of GV85)
GV95	Lock washer, 7/16 in.	G120*		Nut, self threading, 3/16 in.
GV96	Repair kit, (consists of GV8, GV9, GV42, GV43, GV45, GV46, GV47 and GV49)	G121		Actuator bracket
GV97	Valve and rack subassembly (does not include the			

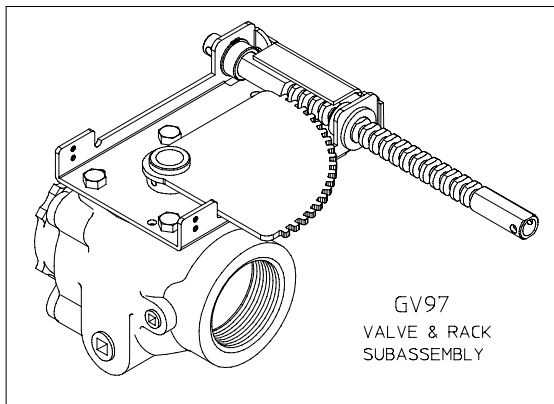
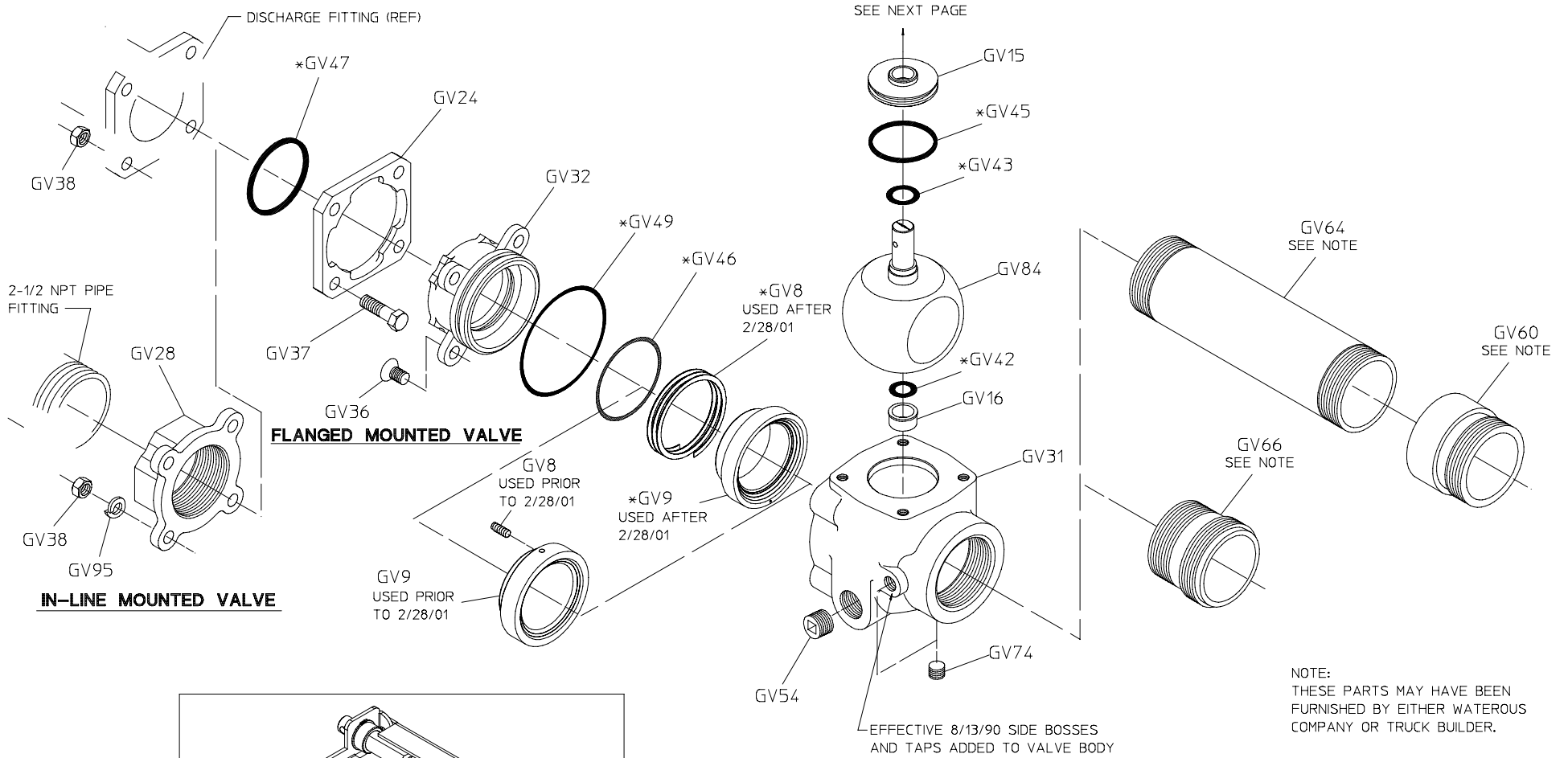

GV96

REPAIR KIT

* PART OF REPAIR KIT GV96

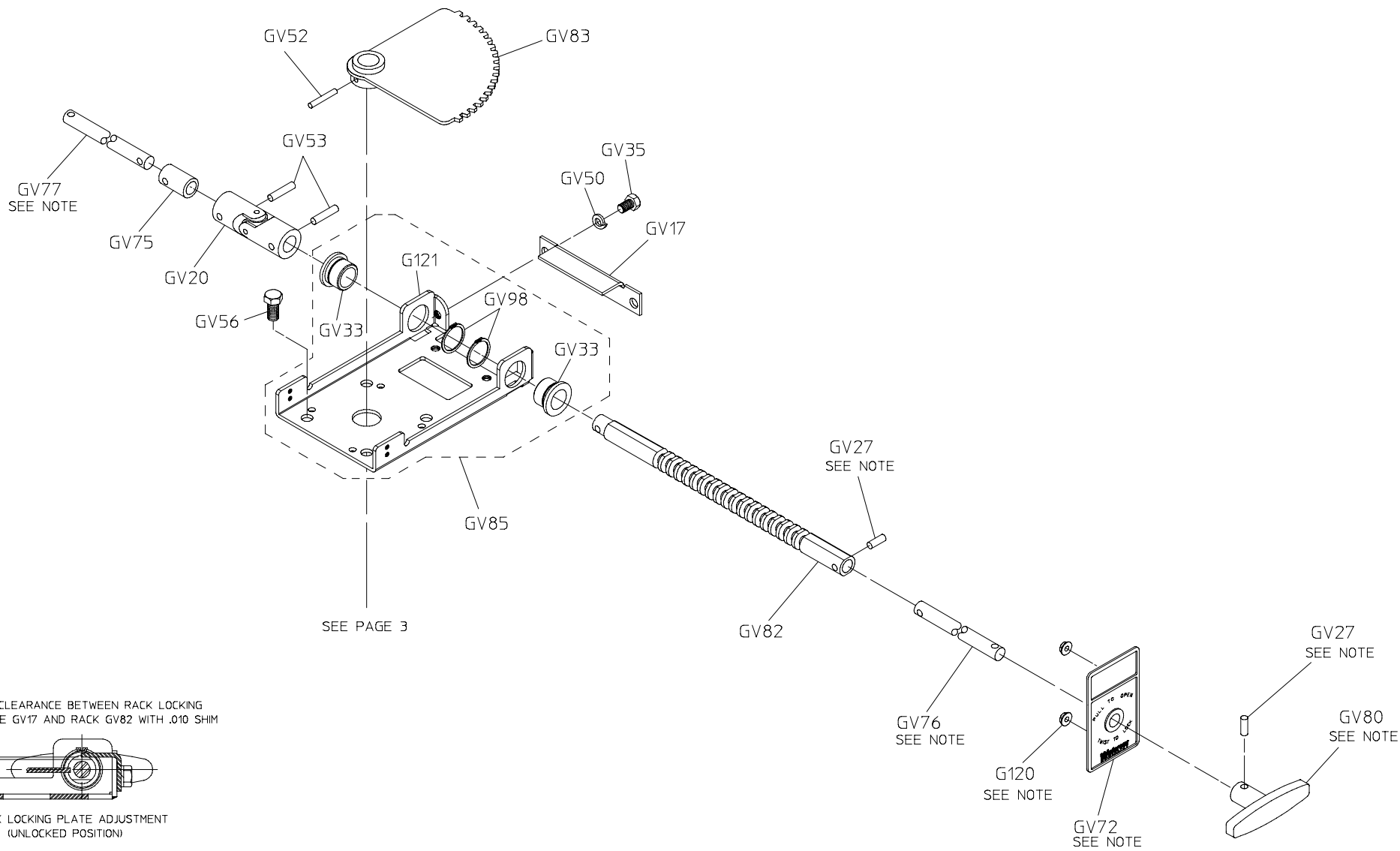

NOTE:
THIS PART MAY HAVE BEEN FURNISHED BY
EITHER WATEROUS COMPANY OR ORIGINAL
EQUIPMENT MANUFACTURER

ASSEMBLIES BUILT AFTER 9/11/06

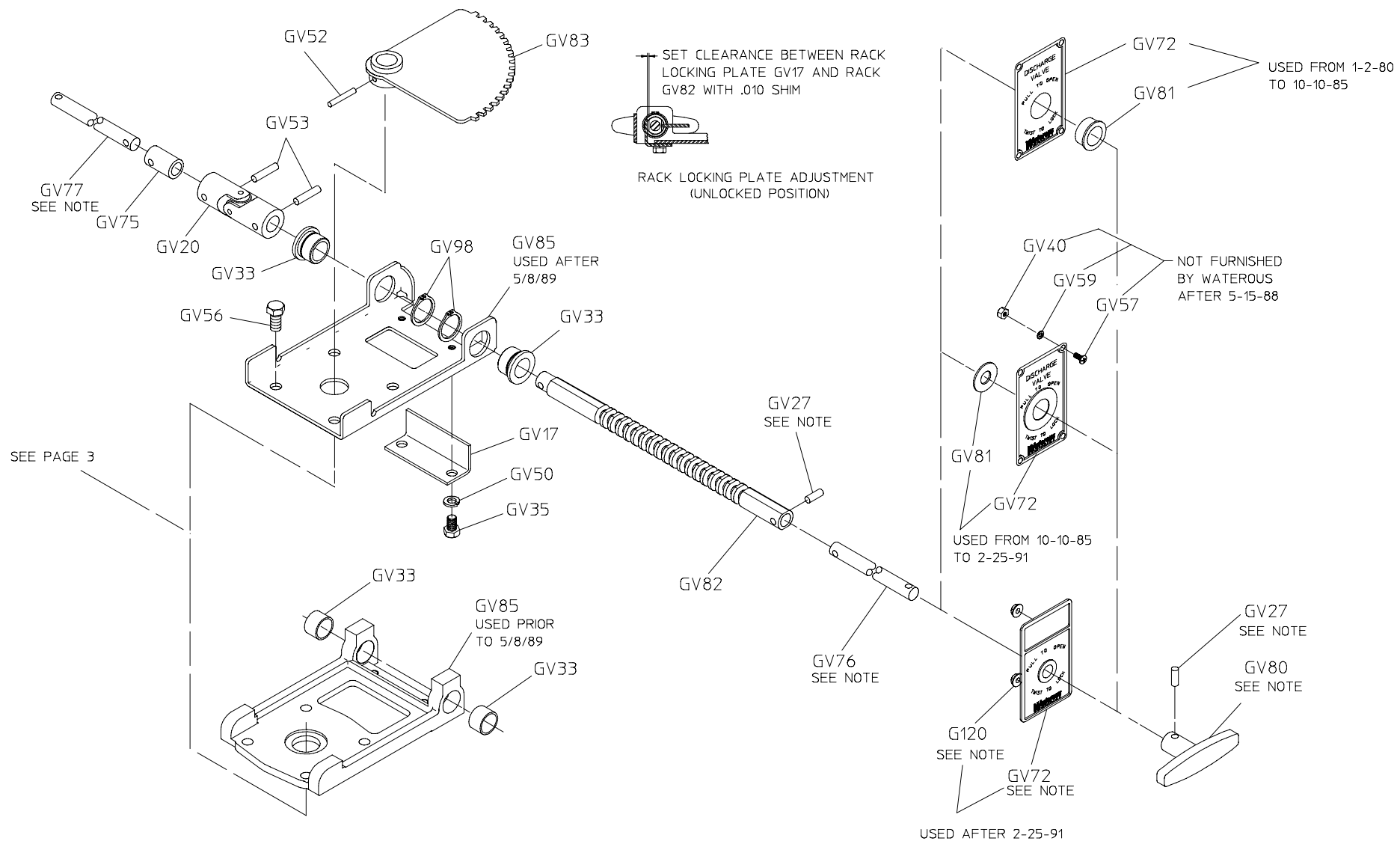

NOTE: THIS PART MAY HAVE BEEN FURNISHED BY
EITHER WATEROUS COMPANY OR ORIGINAL
EQUIPMENT MANUFACTURER

ASSEMBLIES BUILT PRIOR TO 9/11/06