



Document Number	Issue Date	Rev. Date
SPL81004	03/77	05/11/12

Model TMS P.T.O. Service Parts List

Index:

Component		See Page
Case		2, 3
Driveline	1-3/4 Inch	4, 5
	2 Inch	6, 7
Shift Mechanism		8, 9
Optional	Driveline Output Shaft	Speedometer
		Parking Brake Provision
	Hydraulic Output Flanges	

Case

REF. NO.	DESCRIPTION
T1	Gear Case, Front Half
T2	Gear Case Gasket
T3	Gear Case, Rear Half
T4	Driven Gear
T56	Bearing Cover
T58	Magnetic Drain Plug, 1/2 in.
T59	Breather, 1/2 in.
T60	Street Elbow, 90 Degrees, 1/2 in.
T61	Serial Plate
T62	Round Head Drive Screw, No. 6 x 1/4 in.
T63	Square Head Pipe Plug, 1 in.

REF. NO.	DESCRIPTION
T64	Square Head Pipe Plug, 3/4 in.
T65	Hex Head Screw, 3/8-16 x 1 in.
T67	Hex Head Screw with Thread Sealant, 3/8-16 x 1-1/4 in.
T68	Lock Washer, 3/8 in.
T69	Hex Head Screw, 1/2-13 x 3/4 or 1 in., Grade 5
T70	Lock Washer, 1/2 in.
T71	Hex Head Screw, 3/8-24 x 1-3/4 or 1 in., Grade 5
T72	Hex Head Screw, 3/8-24 x 3-1/2 in. Grade 5 (Used Prior to August 2, 1988)
T73	Hex Nut, 3/8-24
T75	Dowel Pin, 3/8 x 1 in.
T87	Gasket and Shim Kit (Includes T2, T6, T9, T12, T18, T24, T35 and T57)

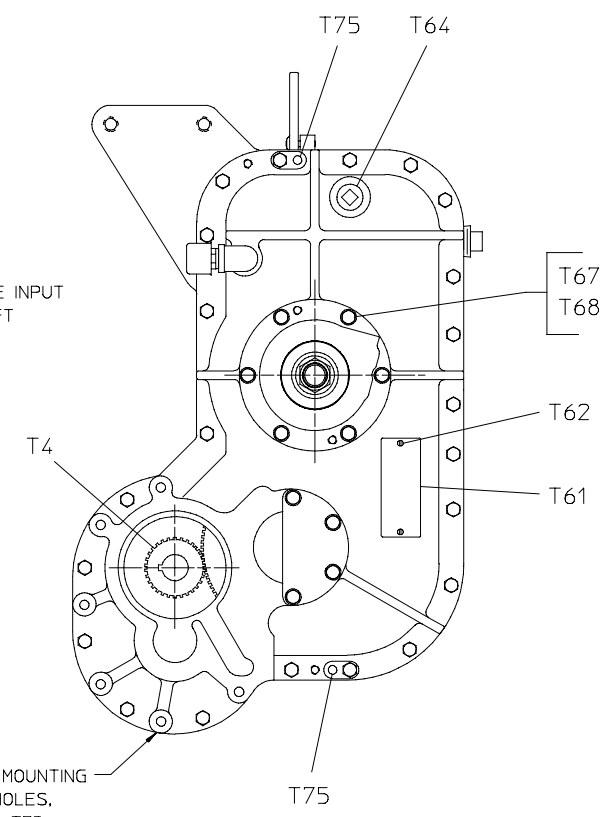
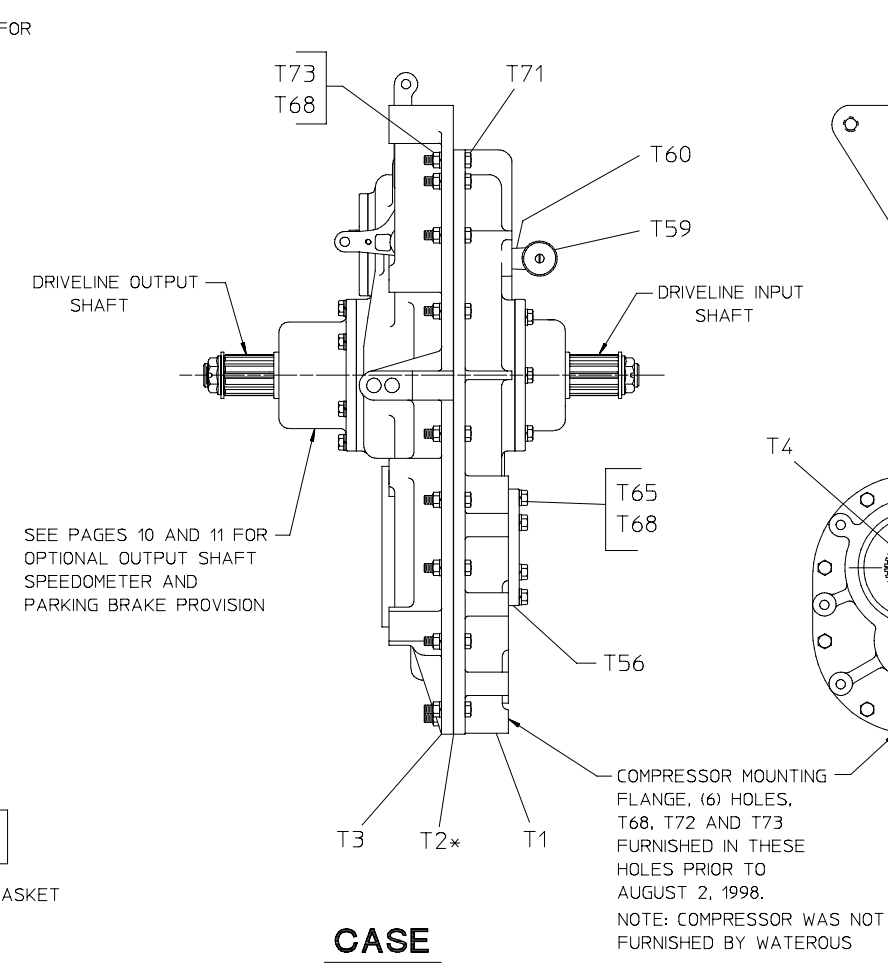
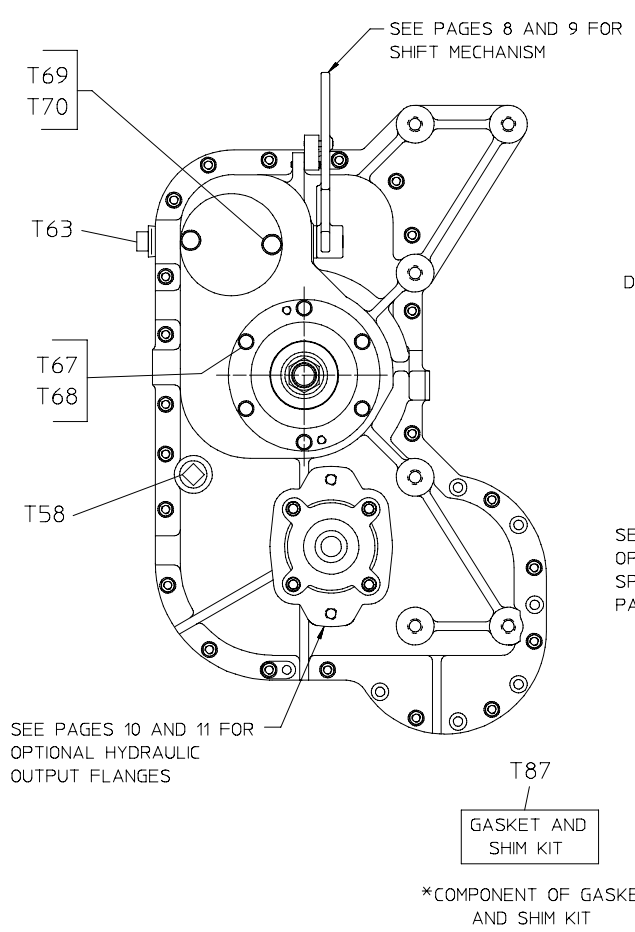

1-3/4 in. Driveline

REF. NO.	DESCRIPTION
T1	Gear Case, Front Half
T2	Gear Case Gasket
T3	Gear Case, Rear Half
T4	Driven Gear
T8	Idler Shaft Ball Bearing
T9	Drive and Coupling Shaft Housing Shim
T10	Coupling Shaft Housing
T11	Plain Washer, 1 in.
T12	Shaft Nut, 1-20
T13	Oil Seal Sleeve
T14	Drive and Coupling Shaft Housing Oil Seal, 2 x 2.884 in.
T15	Coupling Shaft Ball Bearing
T16	Coupling Shaft Bearing Spacer
T19	Shift Shaft
T43	Drive Shaft Pilot Ball Bearing
T44	Shift Collar

REF. NO.	DESCRIPTION
T45	Drive Shaft
T46	Ball Bearing
T47	Drive Shaft Bearing Spacer
T48	Retaining Ring
T49	Drive Shaft Ball Bearing
T50	Drive Shaft Bearing Spacer
T51	Drive Shaft Housing
T52	Cotter Pin, SS, 1/8 x 1-3/4 in.
T53	Drive Gear
T54	Idler Gear
T55	Idler Shaft
T56	Bearing Cover
T57	Bearing Cover O-ring, 2-7/8 x 3-1/8 in.
T74	Heat Treated Square Key, 3/8 x 1-1/4 in.
T76	Coupling Shaft
T87	Gasket and Shim Kit (Includes T2, T6, T9, T12, T18, T24, T35 and T57)

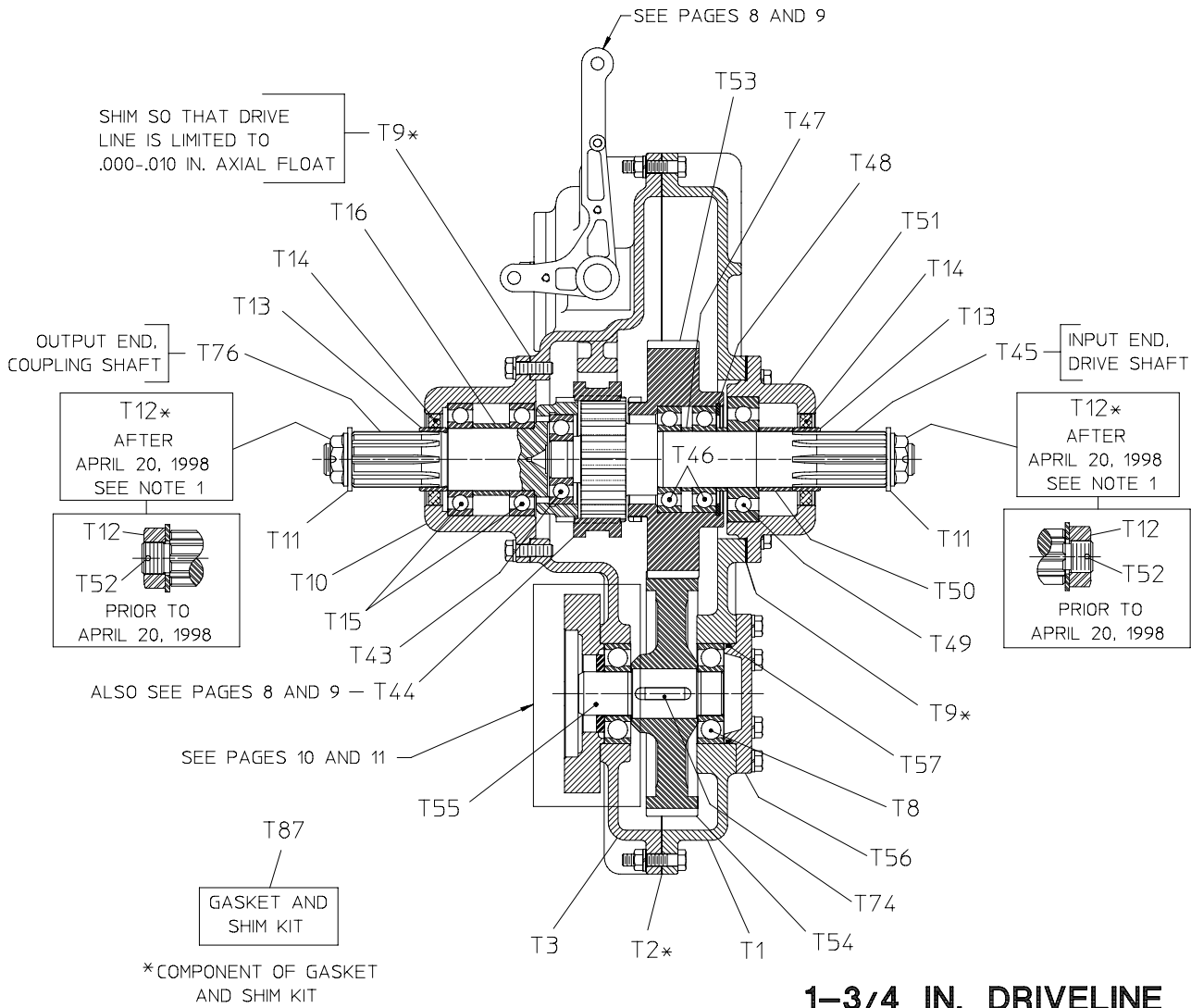

1-3/4 IN. DRIVELINE

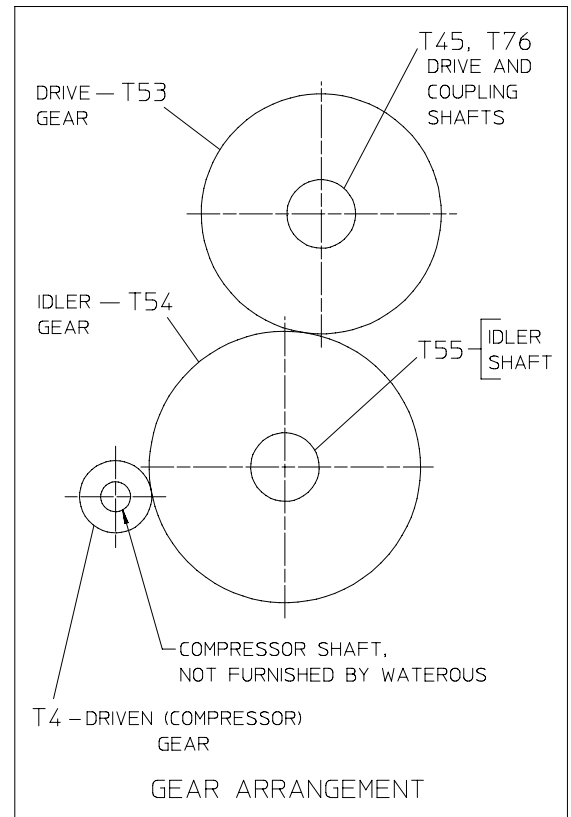

NOTE:
1. TORQUE NUT TO 275-325 LB-FT.

2 in. Driveline

REF. NO.	DESCRIPTION
T1	Gear Case, Front Half
T2	Gear Case Gasket
T3	Gear Case, Rear Half
T4	Driven Gear
T8	Idler Shaft Ball Bearing
T9	Drive and Coupling Shaft Housing Shim
T10	Coupling Shaft Housing
T12	Shaft Nut, 1-1/4-18
T13	Oil Seal Sleeve
T14	Drive and Coupling Shaft Housing Oil Seal, 2-1/2 x 3-1/4 in.
T15	Coupling Shaft Ball Bearing
T16	Coupling Shaft Bearing Spacer
T43	Drive Shaft Pilot Ball Bearing
T44	Shift Collar

REF. NO.	DESCRIPTION
T45	Drive Shaft
T46	Ball Bearing
T47	Drive Shaft Bearing Spacer
T48	Retaining Ring
T49	Drive Shaft Ball Bearing
T50	Drive Shaft Bearing Spacer
T51	Drive Shaft Housing
T52	Cotter Pin, SS, 1/8 x 1-3/4 in.
T53	Drive Gear
T54	Idler Gear
T55	Idler Shaft
T56	Bearing Cover
T57	Bearing Cover O-ring, 2-7/8 x 3-1/8 in.
T74	Heat Treated Square Key, 3/8 x 1-1/4 in.
T76	Coupling Shaft
T87	Gasket and Shim Kit (Includes T2, T6, T9, T12, T18, T24, T35 and T57)

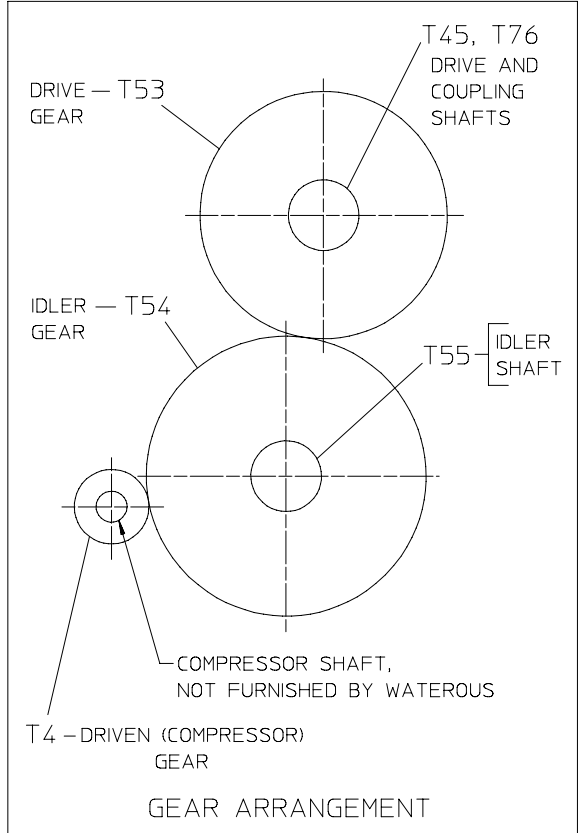
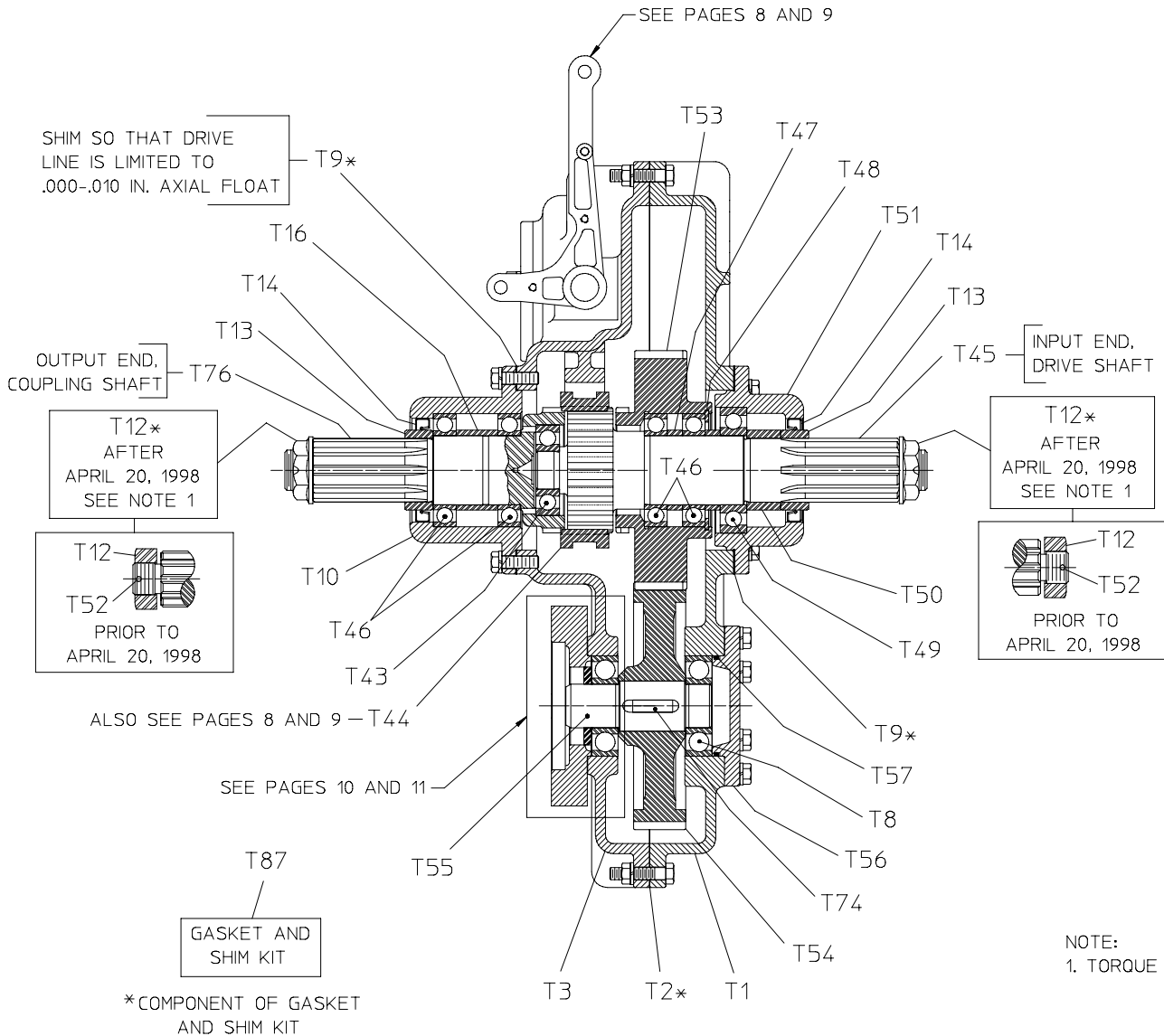

NOTE:
1. TORQUE NUT TO 475-525 LB.-FT.

2 IN. DRIVELINE

Shift Mechanism

REF. NO.	DESCRIPTION
T17	Shift Cover (Not Used if PTO has Electric Shift)
T18	Shift Cover Gasket
T19	Shift Shaft
T20	Shift Arm
T21	Heavy Duty Spirol Pin, SS, 5/16 x 1-3/8 in.
T22	Shift Arm Spacer
T23	Upper Shift Shaft Sleeve Bushing
T24	Shift Arm O-ring, 7/8 x 1 in.
T25	Shift Fork Assembly (Includes T27)
T26	Shifter Shoe Stud (Used Prior to April 10, 2006)
T27	Shifter Shoe
T28	Shift Fork Spacer
T29	Sector Gear
T30	Heavy Duty Spirol Pin, SS, 3/8 x 1-3/4 in. (Used Prior to December 20, 2002)
T31	Lower Shift Shaft Bushing

REF. NO.	DESCRIPTION
T32	Locking Arm Assembly
T33	Shifter Shoe
T34	Pivot Pin
T35	Pivot Pin O-ring, 3/8 x 1/2 in.
T36	Cotter Pin, SS, 1/8 x 5/8 in.
T37	Adjusting Screw Retainer
T38	Adjusting Screw
T39	Spirol Pin, SS, 1/4 x 1-1/4 in.
T40	Shift Arm Spring Housing
T41	Shift Arm Spring
T53	Drive Gear
T63	Square Head Pipe Plug, 1 in.
T87	Gasket and Shim Kit (Includes T2, T6, T9, T12, T18, T24, T35 and T57)
T88	Shoulder Screw, 3/8 x 1-3/4 in. (Used After December 20, 2002)
T89	Flextop Locknut, 5/16-18 (Used After December 20, 2002)

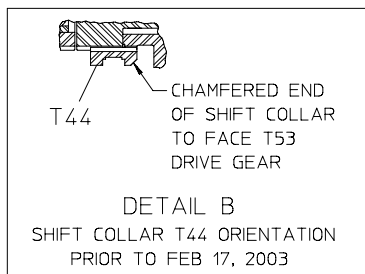
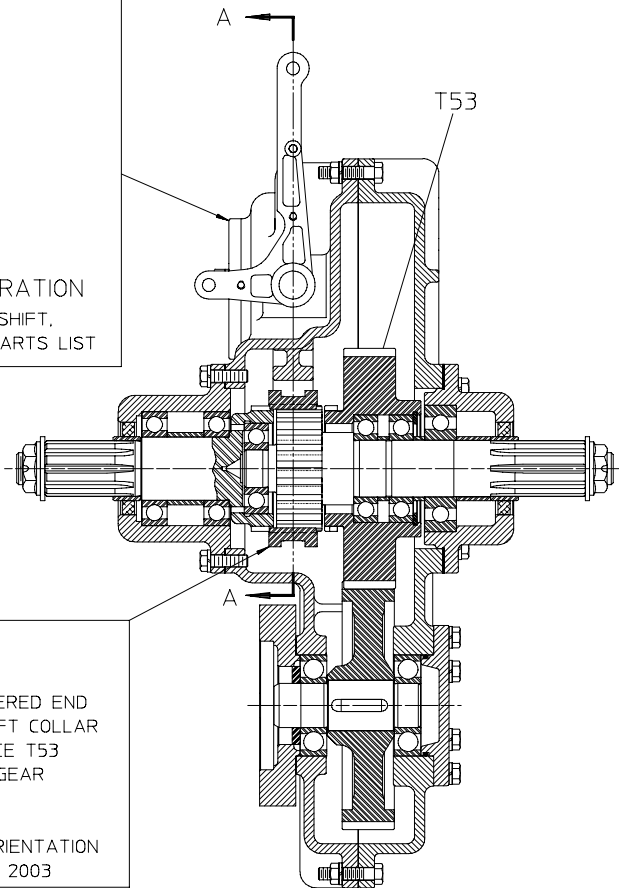
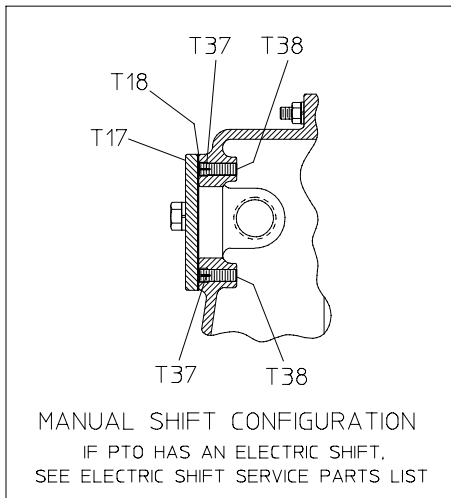

SHIFT MECHANISM

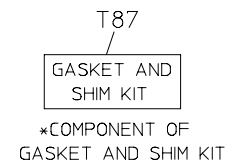
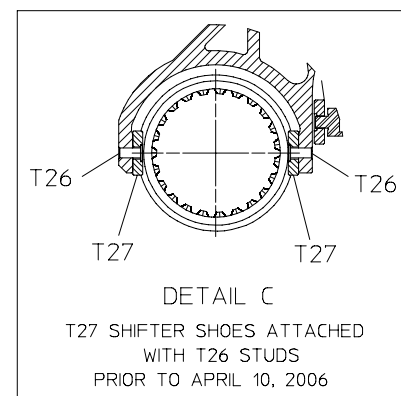
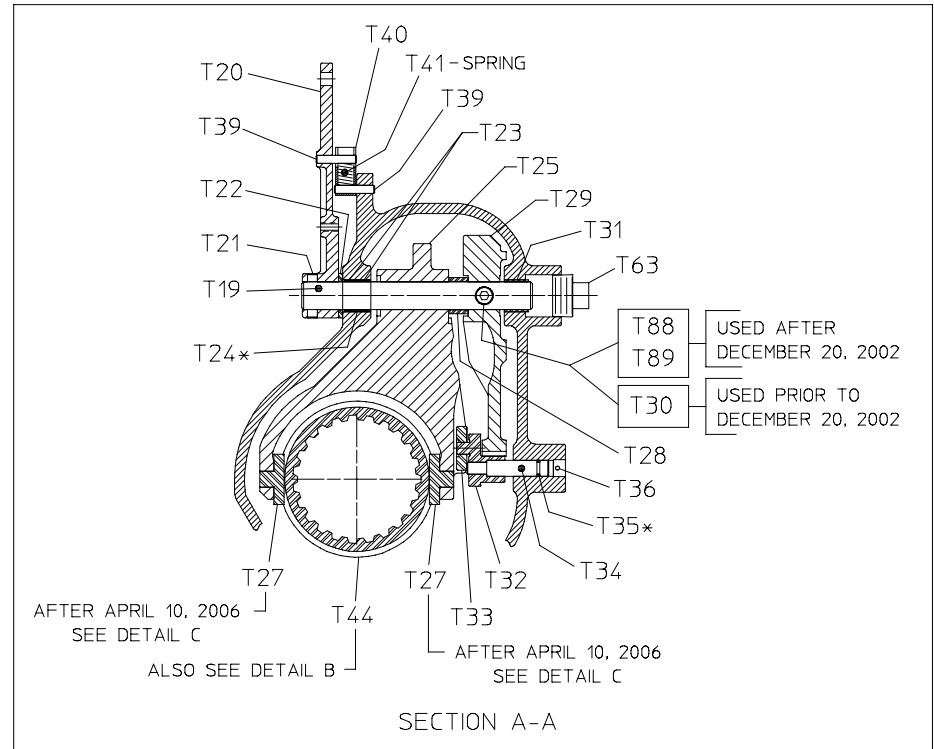

Optional Speedometer and Parking Brake Provision

REF. NO.	DESCRIPTION
T10	Coupling Shaft Housing
T42	Drain Pipe
T55	Idler Shaft
T76	Coupling Shaft
T77	Square Head Pipe Plug, 1/8 in.
T78	Tachometer Drive Gear
T79	Gear Spacer
T80	Woodruff Key
T81	Tachometer Drive Gear Cap (Used Prior to February 1, 1989)
T82	Tachometer Drive Gear Sleeve
T83	Tachometer Driven Gear
T84	Tachometer Driven Gear Bushing
T85	Retainer Bushing, 1/2-20
T86	Counterbore Screw, 3/8-16 x 1-1/4 in.

Optional Hydraulic Output Flanges

REF. NO.	DESCRIPTION
T5	Hydraulic Pump Adapter
T6	Pump Adapter Gasket
T7	Idler Shaft Oil Seal, 1-1/8 x 1-5/8 in. for Type CG Flange, 1-3/8 x 2-7/16 in. for SAE Class B Flange
T8	Idler Shaft Ball Bearing
T55	Idler Shaft
T65	Hex Head Screw, 3/8-16 x 1 in.
T68	Lock Washer, 3/8 in.
T74	Heat Treated Square Key, 3/8 x 1-1/4 in.
T86	Counterbore Screw, 3/8-16 x 1-1/4 in.

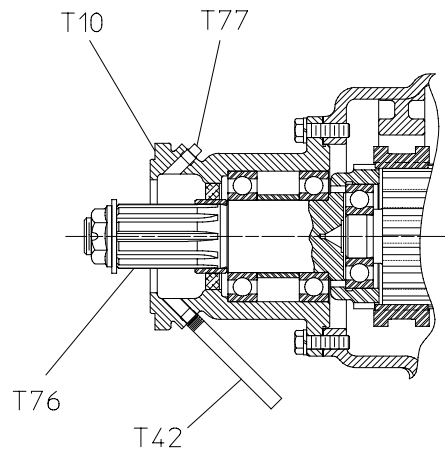

PARKING BRAKE PROVISION
WITHOUT SPEEDOMETER

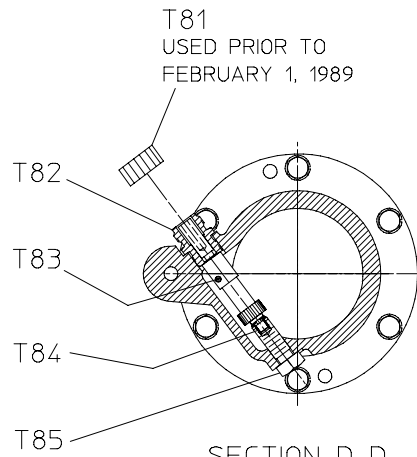

SECTION D-D

PARKING BRAKE PROVISION
WITH SPEEDOMETER

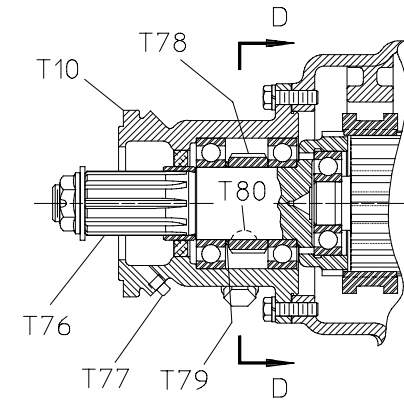

OPTIONAL SPEEDOMETER AND PARKING BRAKE PROVISION

(DRIVELINE OUTPUT SHAFT)

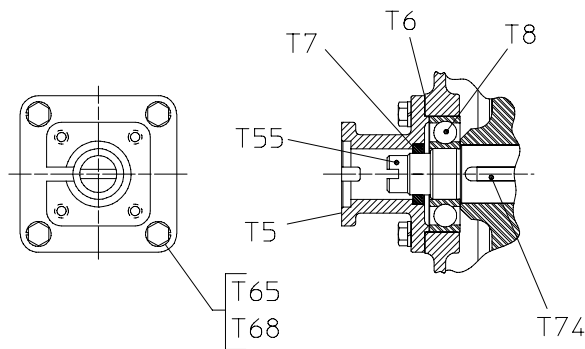

TYPE GC 4-BOLT FLANGE

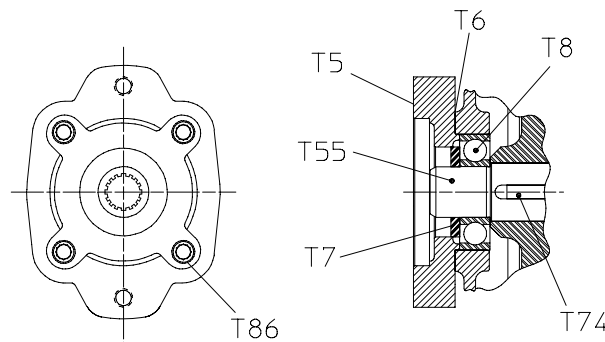

SAE CLASS B 2-BOLT FLANGE

OPTIONAL HYDRAULIC OUTPUT FLANGES