



Document Number SPL81094	Issue Date 05/89	Rev. Date 1/19/18
------------------------------------	----------------------------	-----------------------------

CX Series Pump Impeller Shaft Service Parts List

Index:

Pump Model <i>(Located on Pump Serial Plate)</i>	Transmission Model <i>(Located on Pump Serial Plate)</i>								See Page			
									Seal Type		Optional Impeller Inducer	Packing Arrangements
	C10 Series	C20 Series	D Series	K Series	P Series	T Series	Q Series	Y Series	Packing	Mechanical Seal		
CX, CXN, CXR, CXS, CXV	C10C C10D C10E C10F	C20B C20C C20D C20E C20F	-	K, KC	PA	T	-	YC, YCX YD, YDX YE, YEX YF, YFX	2, 3	4, 5	12, 13	14, 15
	-	-	D	-	-	-	-	-	-	6, 7	-	-
	-	-	-	-	-	-	QB (Front Facing)	-	-	8, 9	-	-
	-	-	-	-	-	-	QB (Rear Facing)	-	-	10, 11	-	-

Packing Seal

REF NO.	DESCRIPTION
S1	Impeller shaft
S2	Square key, 5/16 x 1-5/16 in.
S3	Flinger ring
S4	Unbalanced nut
S5	Plain brass washer, 1/4 in.
S6	Packing gland
S7	Packing gland stud
S9	Wear ring

REF NO.	DESCRIPTION
S10	Impeller
S12	Square key, SS or Monel, 1/4 x 1-7/16 in.
S13	Impeller nut
S15	Packing replacement kit, BFG rings
S16	Cotter pin, SS, 1/8 x 1-3/4 in. or Monel, 3/16 x 1-1/4 in.
S17	Wear ring
S18	Flinger grommet, deflector grommet or V-ring flinger
S19	Flinger disk

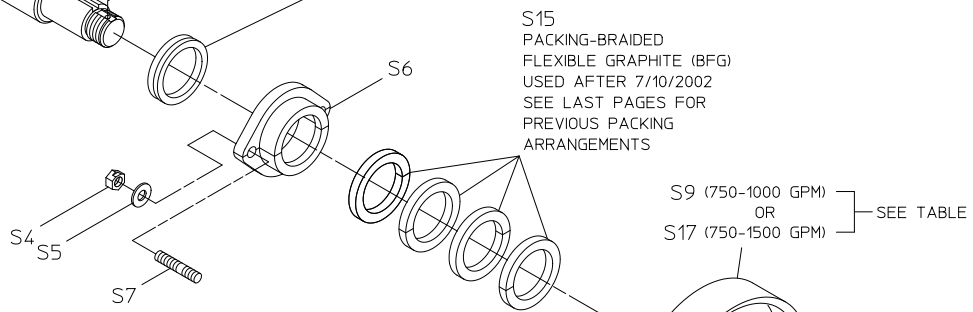
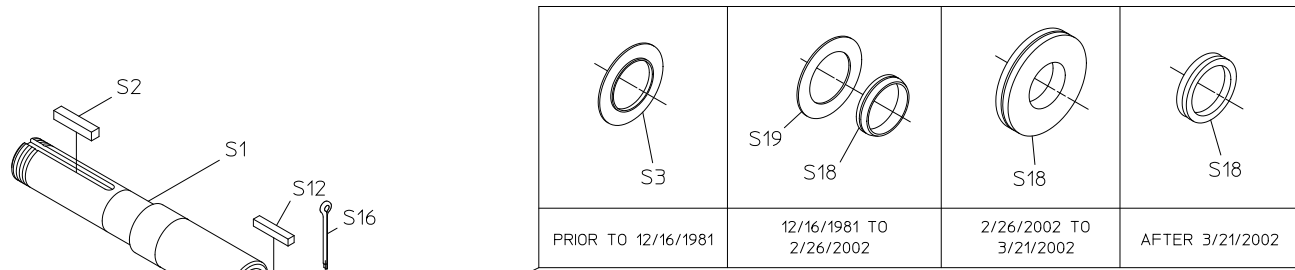

IMPELLER AND WEAR RING DIMENSIONS FOR PART IDENTIFICATION

PUMP CAPACITY	INSIDE DIA OF IMPELLER EYE REF NO. S10	WEAR RING				
		IN PUMP BODY		IN INTAKE ADAPTER		
		REF NO.	WIDTH	REF NO.	HEATHER JACKET	WIDTH
750, 1000 GPM	5.875	S9	1.000	S11	WITH	1.187
	6.200	S17	.940	S17	WITHOUT	1.500
1250, 1500 GPM	6.200	S17	.940	S17	WITH OR WITHOUT	.940

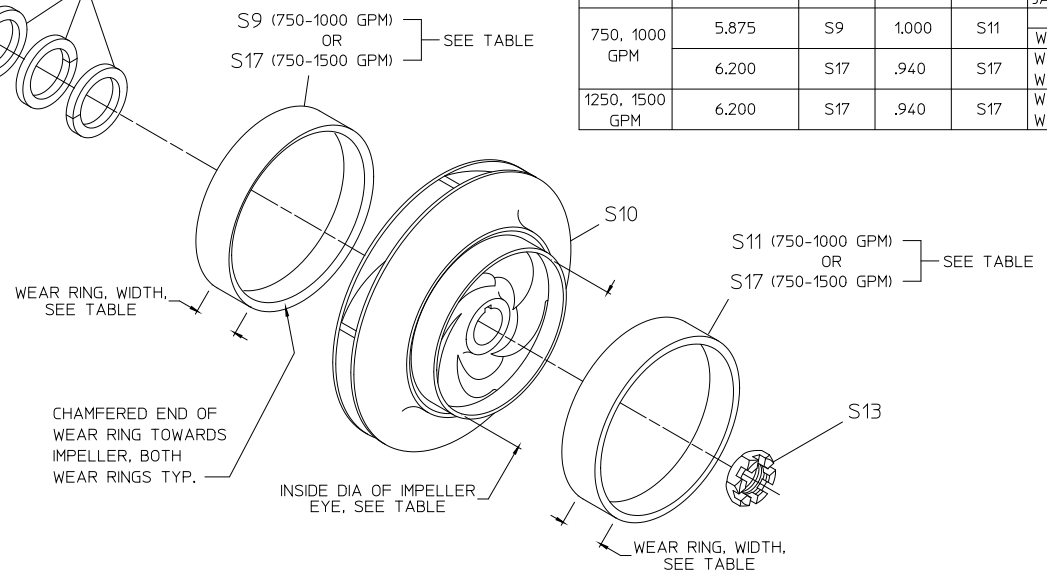

PACKING SEAL

Mechanical Seal
C10, C20, K, P, T and Y Series Transmissions

REF NO.	DESCRIPTION
S1	Impeller shaft
S2	Square key, 5/16 x 1-5/16 in.
S3	Flinger ring
S9	Wear ring
S10	Impeller
S11	Wear ring
S12	Square key, SS or Monel, 1/4 x 1-7/16 in.
S13	Impeller nut

REF NO.	DESCRIPTION
S14	Mechanical seal
S16	Cotter pin, SS, 1/8 x 1-3/4 in. or Monel, 3/16 x 1-1/4 in.
S17	Wear ring
S18	Flinger grommet, deflector grommet or V-ring flinger
S19	Flinger disk
S20	Spring retainer (Monel shafts only, prior to 6/12/1992)
S28	Retaining ring, 1.150 ID x .093 Wide

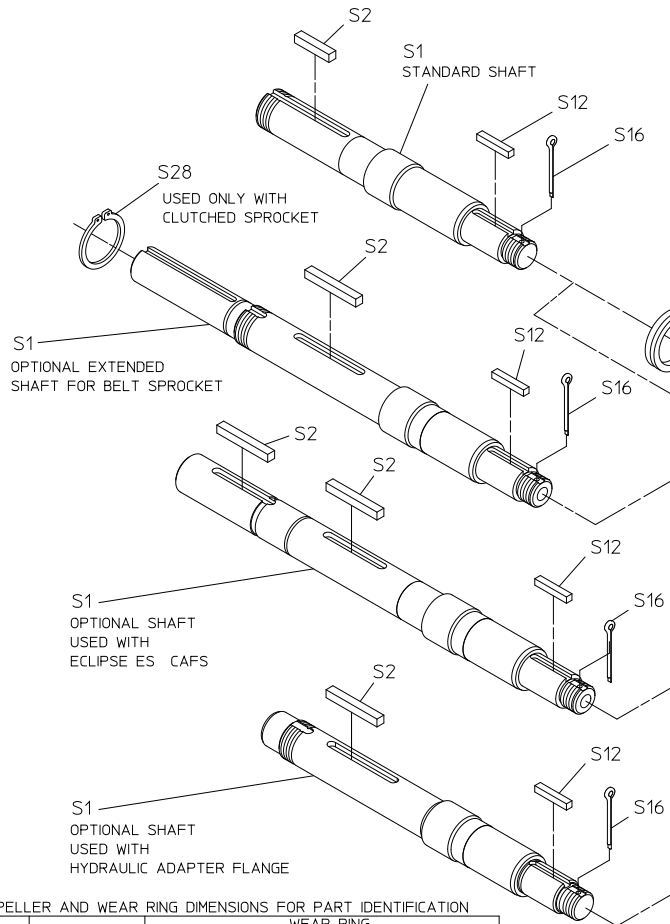

PRIOR TO 12/16/1981	12/16/1981 TO 2/26/2002	2/26/2002 TO 3/21/2002	AFTER 3/21/2002

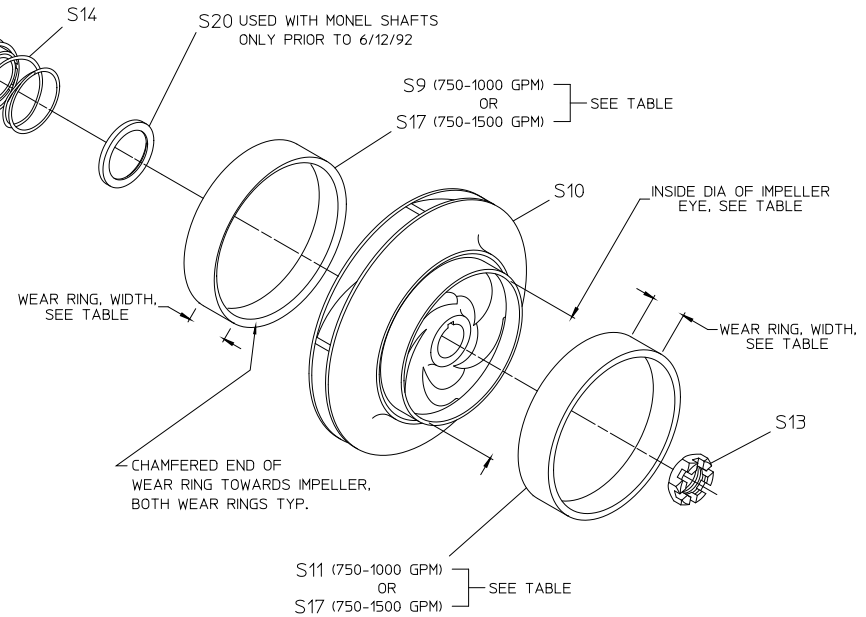

IMPELLER AND WEAR RING DIMENSIONS FOR PART IDENTIFICATION

PUMP CAPACITY	INSIDE DIA OF IMPELLER EYE REF NO. S10	WEAR RING				
		IN PUMP BODY		IN INTAKE ADAPTER		
		REF NO.	WIDTH	REF NO.	WIDTH	
750, 1000 GPM	5.875	S9	1.000	S11	WITH HEATHER JACKET	1.187
					WITHOUT HEATHER JACKET	1.500
1250, 1500 GPM	6.200	S17	.940	S17	WITH OR WITHOUT HEATHER JACKET	.940

MECHANICAL SEAL
C10, C20, K, P, T, AND Y SERIES TRANSMISSIONS

**Mechanical Seal
D Series Transmission**

REF NO.	DESCRIPTION
S1	Impeller shaft
S10	Impeller
S12	Square key, SS or Monel, 1/4 x 1-7/16 in.
S13	Impeller nut
S14	Mechanical seal
S16	Cotter pin, SS, 1/8 x 1-3/4 in. or Monel, 3/16 x 1-1/4 in.
S17	Wear ring
S18	Flinger grommet, deflector grommet or V-ring flinger

REF NO.	DESCRIPTION
S22	Spacer
S23	End yoke, 1350/1410 series
S24	End yoke nut
S25	Wave spring, 80 mm
S26	Ball bearing, single row, double seal
S27	Ball bearing, double row, double seal

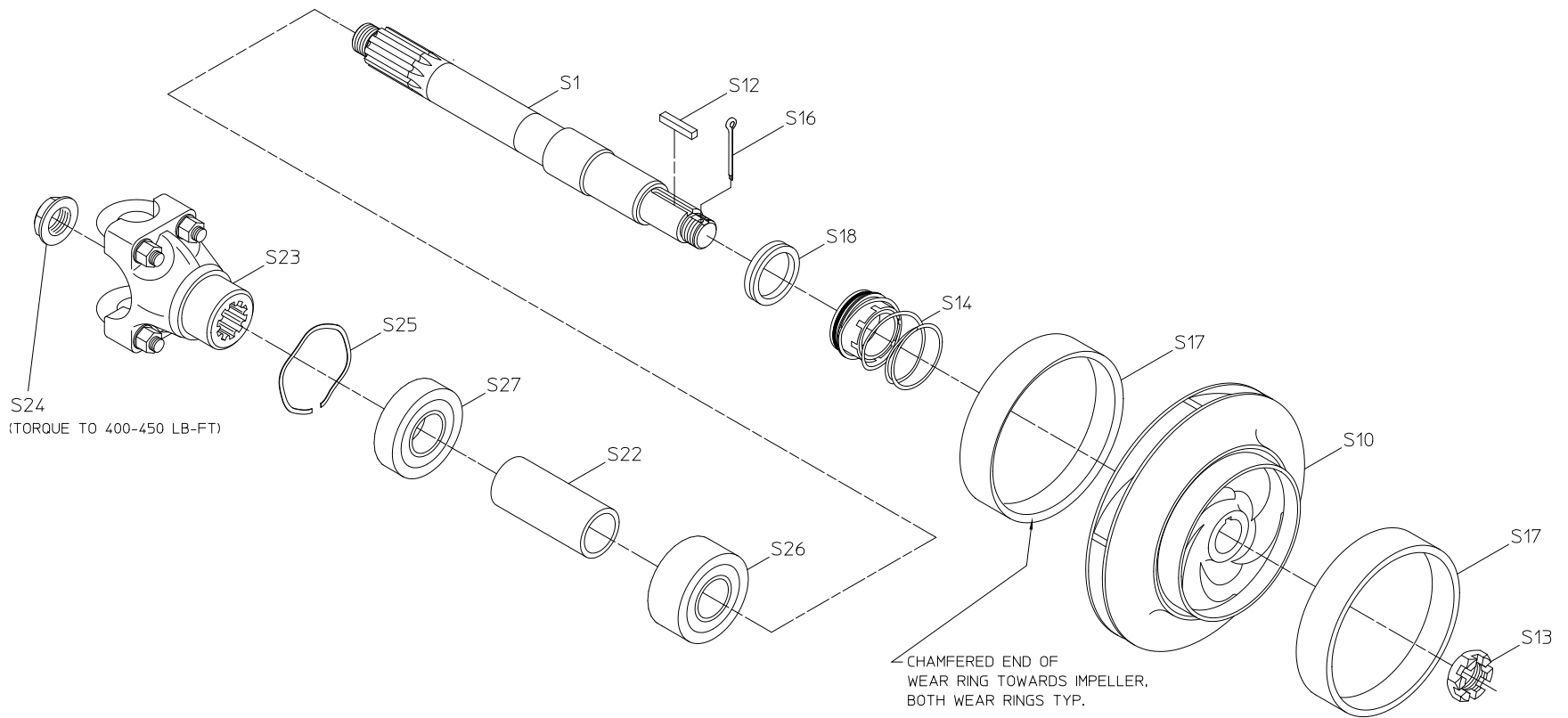

MECHANICAL SEAL
D SERIES TRANSMISSIONS

**Mechanical Seal
QB Series Transmission**

REF NO.	DESCRIPTION
S1	Impeller shaft
S2	Square key, 1/2 x 1-3/4 in.
S10	Impeller
S12	Square key, 1/4 x 1-7/16 in.
S13	Impeller Nut
S14	Mechanical Seal
S16	Cotter pin, SS, 1/8 x 1-3/4 in.
S17	Wear ring
S18	V-ring flinger

REF NO.	DESCRIPTION
S28	Spacer, 2.039
S29	Spacer, 2.319
S30	Ball bearing, double row
S31	Ball bearing, cylindrical
S32	Bearing washer
S33	Bearing nut

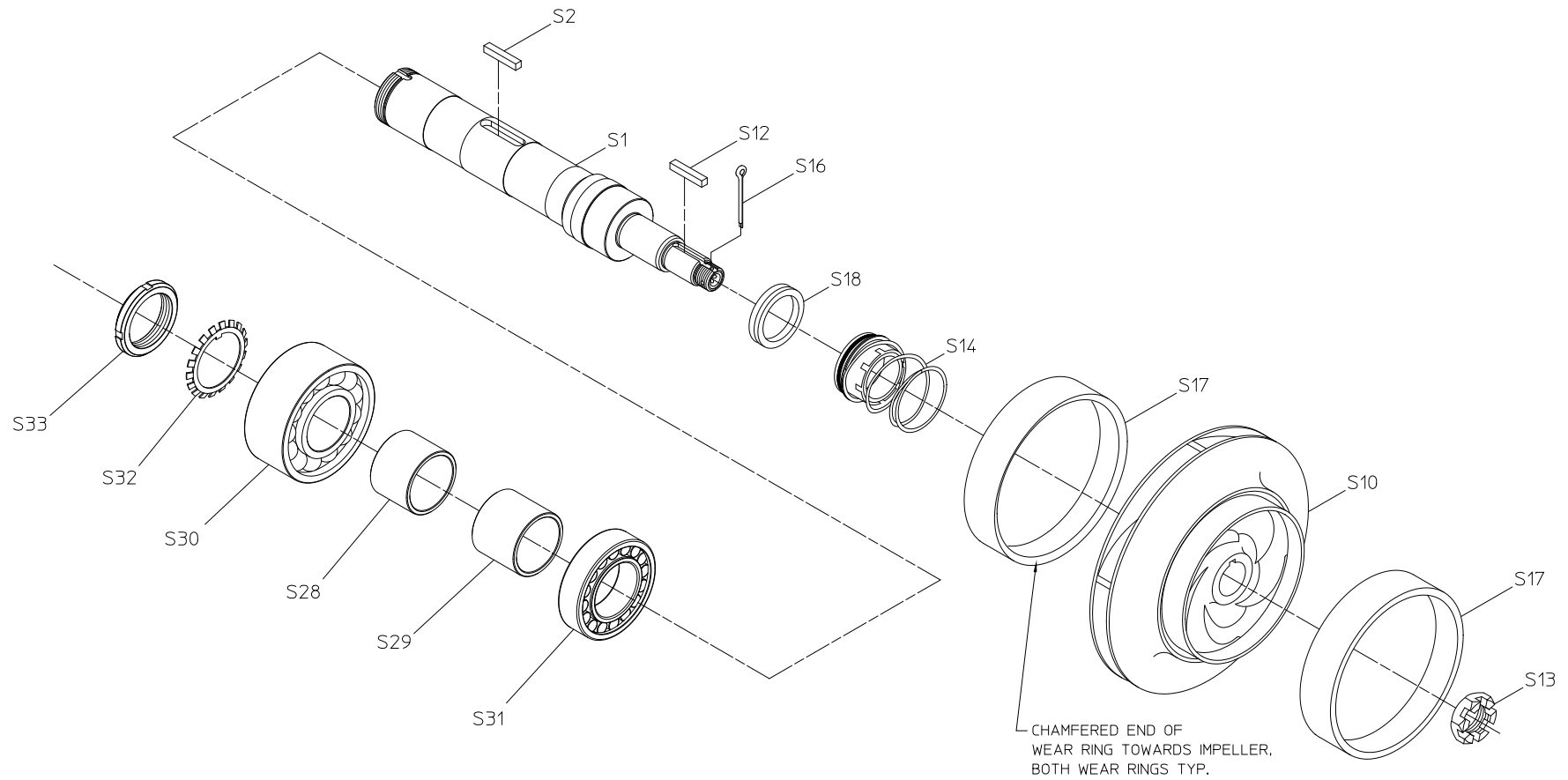

MECHANICAL SEAL
 OB SERIES TRANSMISSIONS
 (FRONT FACING PUMP)

**Mechanical Seal
QB Series Transmission**

REF NO.	DESCRIPTION
S1	Impeller shaft
S2	Square key, 1/2 x 1-3/4 in.
S10	Impeller
S12	Square key, 1/4 x 1-7/16 in.
S13	Impeller Nut
S14	Mechanical Seal
S16	Cotter pin, SS, 1/8 x 1-3/4 in.
S17	Wear ring
S18	V-ring flinger
S25	Wave Spring

REF NO.	DESCRIPTION
S28	Spacer, 2.158
S29	Spacer, 2.950
S30	Ball bearing, single row
S31	Ball bearing, single row
S32	Bearing washer
S33	Bearing nut
S34	Oil Seal Sleeve
S35	Oil Seal

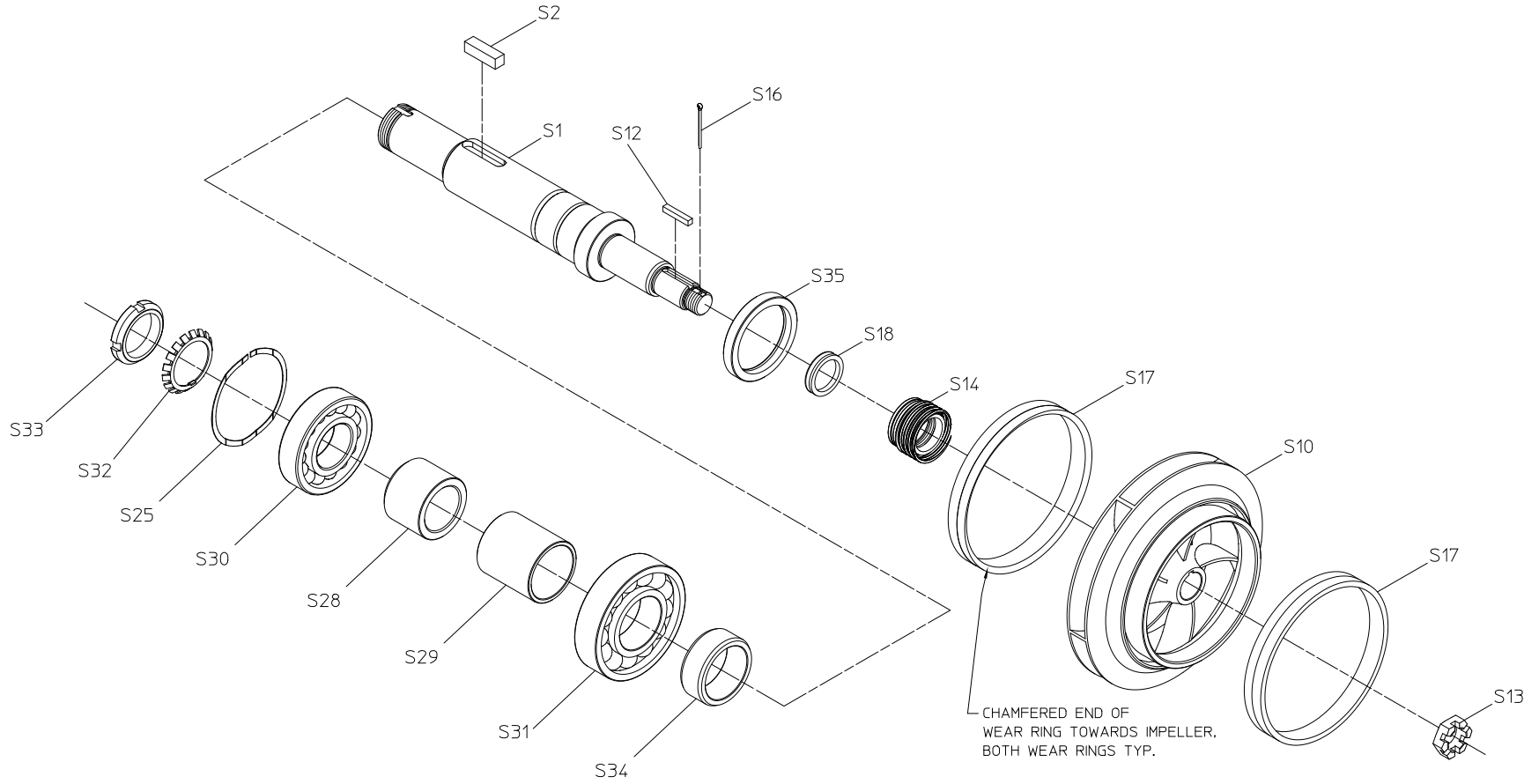

MECHANICAL SEAL
 QB SERIES TRANSMISSIONS
 (REAR FACING PUMP)

Impeller Inducer
C20, K and T Series Transmissions

REF NO.	DESCRIPTION
S1	Impeller shaft
S10	Impeller
S13	Impeller nut
S36	Square key, 3/16 x 1-1/2

REF NO.	DESCRIPTION
S37	Inducer
S38	Nord Lock Washer, 10 mm
S39	Socket head screw, 3/8-16 x 2-3/4

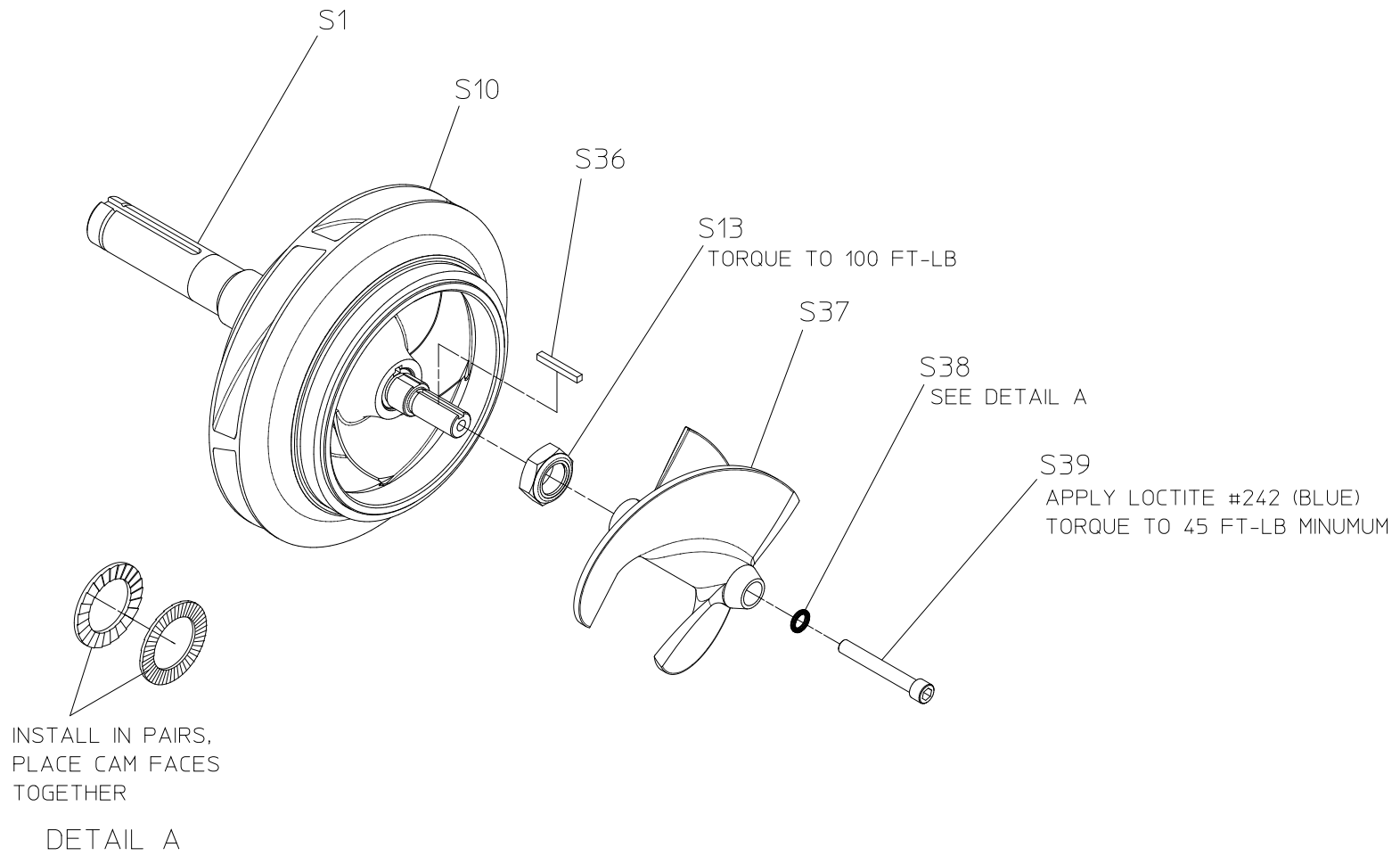

IMPELLER INDUCER

C20, K AND T SERIES TRANSMISSIONS

Packing Arrangements

REF NO.	DESCRIPTION
S8	Packing, replacement kit, Teflon graphite rings
S15	Packing replacement kit, BFG rings

REF NO.	DESCRIPTION
S21	Packing, flexible graphite, split ring

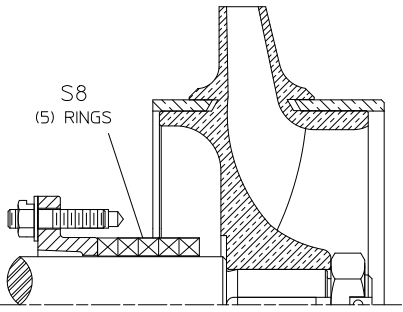
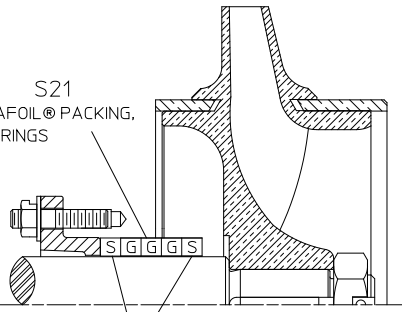
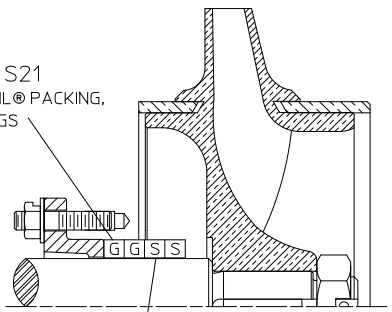
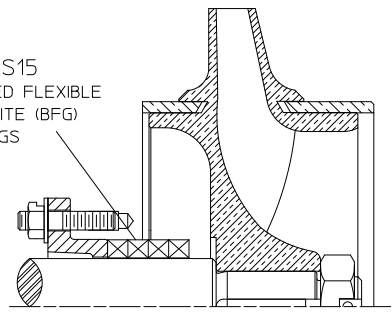
 <p>S8 (5) RINGS</p>	 <p>S21 GRAFOIL® PACKING, (3) RINGS</p> <p>SOFT RING, BRAIDED FILAMENT YARN, (2) RINGS</p>
<p>ARRANGEMENT A ASBESTOS GRAPHITE RINGS USED PRIOR TO 2/1/1984</p>	<p>ARRANGEMENT B FLEXIBLE GRAPHITE (GRAFOIL®) RINGS USED PRIOR TO 1/26/1983</p>
<p>NO LONGER AVAILABLE TEFLON GRAPHITE RINGS WILL BE FURNISHED FOR REPAIRS</p>	<p>REPLACED BY ARRANGEMENT D ARRANGEMENT D WILL BE FURNISHED FOR REPAIRS (INDIVIDUAL S21 RINGS ARE STILL AVAILABLE)</p>
 <p>S21 GRAFOIL® PACKING, (2) RINGS</p> <p>SOFT RING, BRAIDED FILAMENT YARN, (2) RINGS</p>	 <p>S15 BRAIDED FLEXIBLE GRAPHITE (BFG) (4) RINGS</p>
<p>ARRANGEMENT C FLEXIBLE GRAPHITE (GRAFOIL®) RINGS USED FROM 1/26/1983 TO 7/10/2002</p>	<p>ARRANGEMENT D AFTER 7/10/2002 CURRENT CONFIGURATION</p>
<p>REPLACED BY ARRANGEMENT D ARRANGEMENT D WILL BE FURNISHED FOR REPAIRS (INDIVIDUAL S21 RINGS ARE STILL AVAILABLE)</p>	

PACKING ARRANGEMENTS

NOTE: ALWAYS STAGGER JOINTS IN PACKING RINGS.