

Issued: 11/80

Revised: 8/28/18

W A T E R O U S

WATEROUS COMPANY

SOUTH ST. PAUL, MINNESOTA

DISCHARGE VALVE ASSEMBLY, 2-1/2 FF (WITH FLOW METER PROVISION)

REF NO.	DESCRIPTION	REF NO.	DESCRIPTION
GF1	Seal spring or wave spring	GF21	Hex hd bolt, 7/16-20 x 1-1/2 in. or 7/16-14 x 1-1/4 in., grade 5
GF2	Seal	GF22	Hex nut, 1/4-20
GF3	Upper stem bushing	GF23	Hex nut, 7/16-20
GF4	Lower stem bushing	GF24	Hex jam nut, 1/4-28
GF5	Rack locking plate	GF25*	O-ring, 9/16 x 3/4 in.
GF6	Connecting rod	GF26*	O-ring, 3/4 x 15/16 in.
GF7	Sector gear assembly bushing	GF27*	O-ring, 2-1/8 x 2-3/8 in.
GF8	Mounting flange	GF28*	O-ring, 2-7/8 x 3-1/8 in.
GF9	Rack	GF29*	O-ring, 2-3/4 x 3 in.
GF10	Gear sector assembly	GF30*	O-ring, 3-7/8 x 4-1/8 in.
GF11	Valve ball	GF31	Plain washer, 1/2 in.
GF12	Cover	GF32	Lock washer, 5/16 in.
GF13	Control arm	GF33	Roll pin, SS, 3/16 x 1-1/2 in.
GF14	Seal retainer	GF34	Hex socket pipe plug, 1/4 in.
GF15	Bracket subassembly (Stamped steel-includes GF38 & GF61. Used after 5/8/89). (Casting-includes GF38. No longer used after 5/8/89).	GF35	Sq socket pipe plug, 3/4 in.
GF16	Valve body subassembly (includes GF4)	GF36*	Flat socket hd cap screw, zinc pld, 3/8-16 x 3/4 in.
GF17	Flowmeter extension	GF37	Flat socket hd cap screw, zinc pld, 7/16-14 x 3/4 in.
GF18	Cap screw, zinc pld, 5/16-18 x 1/2 in.	GF38	Rack bearing
GF19	Cap screw, zinc plated, 3/8-16 x 3/4 in. for cast bracket; 3/8-16 x 9/16 in. or 5/8 in. for stamped bracket	GF39	Rod end
GF20	Cap screw, 1/4-28 x 1-1/4 in.	GF40	Shoulder bolt, SS, 3/8-16 x 1-1/4 in.
		GF41	Pan hd machine screw, 1/4-28 x 1 in.
		GF42	Universal joint
		GF43	(Refer to GV80)

PLEASE NOTE

WHEN ORDERING PARTS PLEASE SUPPLY PUMP SERIAL NUMBER

SPL81194

PAGE 1 OF 4

W A T E R O U S

WATEROUS COMPANY

SOUTH ST. PAUL, MINNESOTA

DISCHARGE VALVE ASSEMBLY, 2-1/2 FF (WITH FLOW METER PROVISION)

REF NO.	DESCRIPTION	REF NO.	DESCRIPTION
GF44	Universal joint bushing		GF52, GF53, GF54, GF55, GF56, GF58, GF72, GF80 and GF81)
GF45	(Refer to GV27)		
GF46	Roll pin, SS, 1/4 x 1-1/8 in.	GF61	Retaining ring
GF47	(Refer to GV72)	GV27	Roll pin, SS, 1/4 x 11/16 in. (see note below, formerly GF45)
GF48	(Refer to GV40)		
GF49	(Refer to GV57)	GV40	Hex nut, #8-32 (not furnished by Waterous after 5/15/88, formerly GF48)
GF50	(Refer to GV59)		
GF51	Snap bushing (used prior to 10/10/85)	GV57*	Round hd machine screw, SS, #8-32 x 3/8 in. (not furnished by Waterous after 5/15/88, formerly GF49)
GF52*	Hose nipple (See note below)		
GF53*	Control rod, panel side (See note below)	GV59	Lock washer, #8 (not furnished by Waterous after 5/15/88, formerly GF50)
GF54	Discharge adapter (See note below)		
GF55*	Pipe nipple, 4 in. long, brass or galvanized (See note below)	GV72	Panel plate (See note below, formerly GF47)
GF56	Control rod, remote side (See note below)	GV80	Control handle (See note below, formerly GF43)
GF57	Plain washer, 1/4 in.	GV81	Rubber washer (used 10/10/85 to 2/25/91, see note below)
GF58	Gasket		
GF59	Repair kit (includes GF1, GF2, GF25, GF26, GF27, GF28, GF29 and GF30)	GV120	Nut, self-threading, 3/16 in.
GF60	Valve and rack subassembly (does not include the following parts: GF21, GF23, GF27, GF42, GF44, GF46,		Note: This part may have been furnished by either Waterous or original equipment manufacturer.

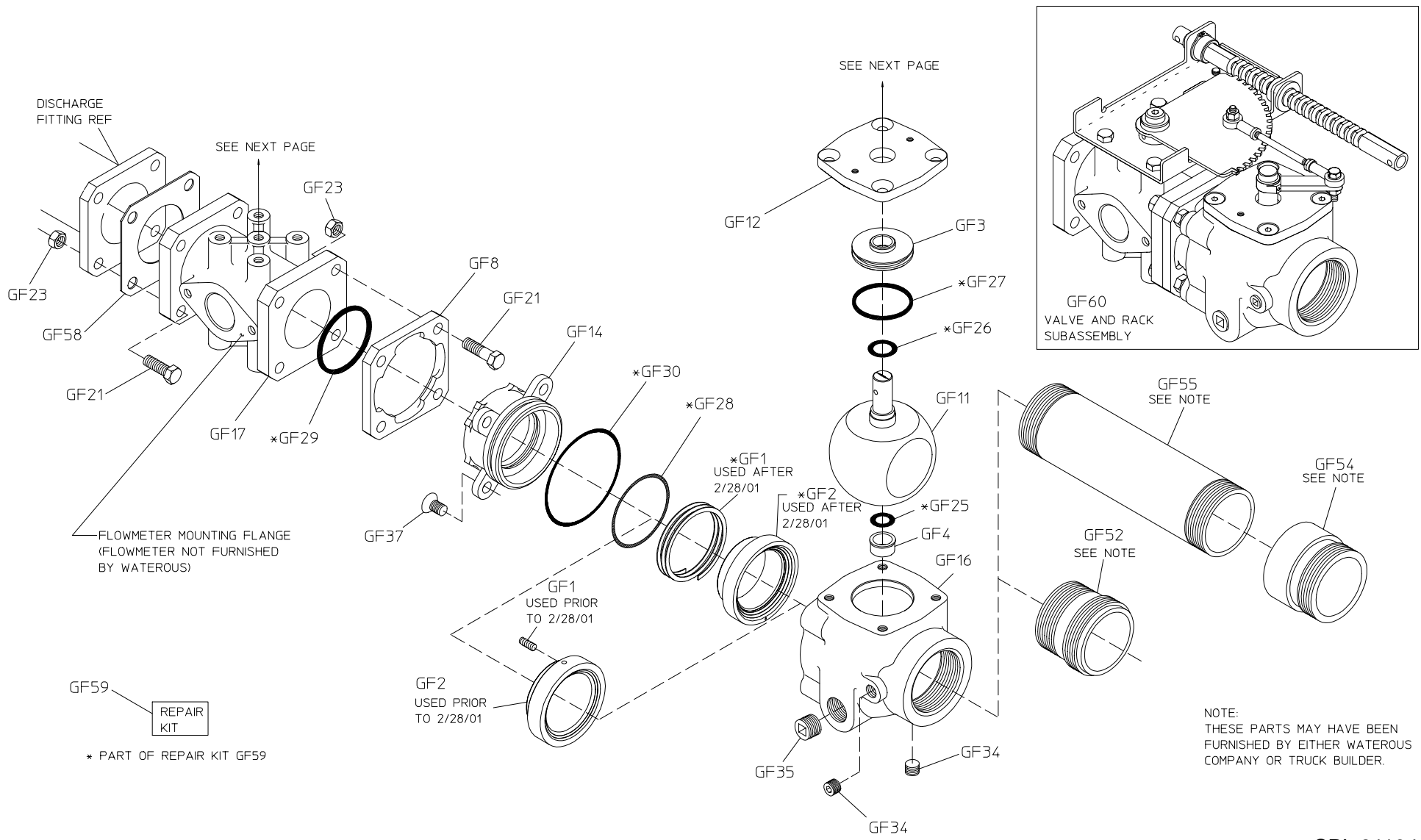

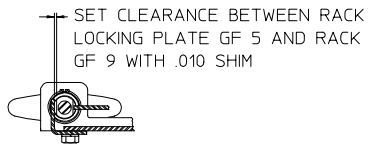

RACK LOCKING PLATE ADJUSTMENT
(UNLOCKED POSITION)

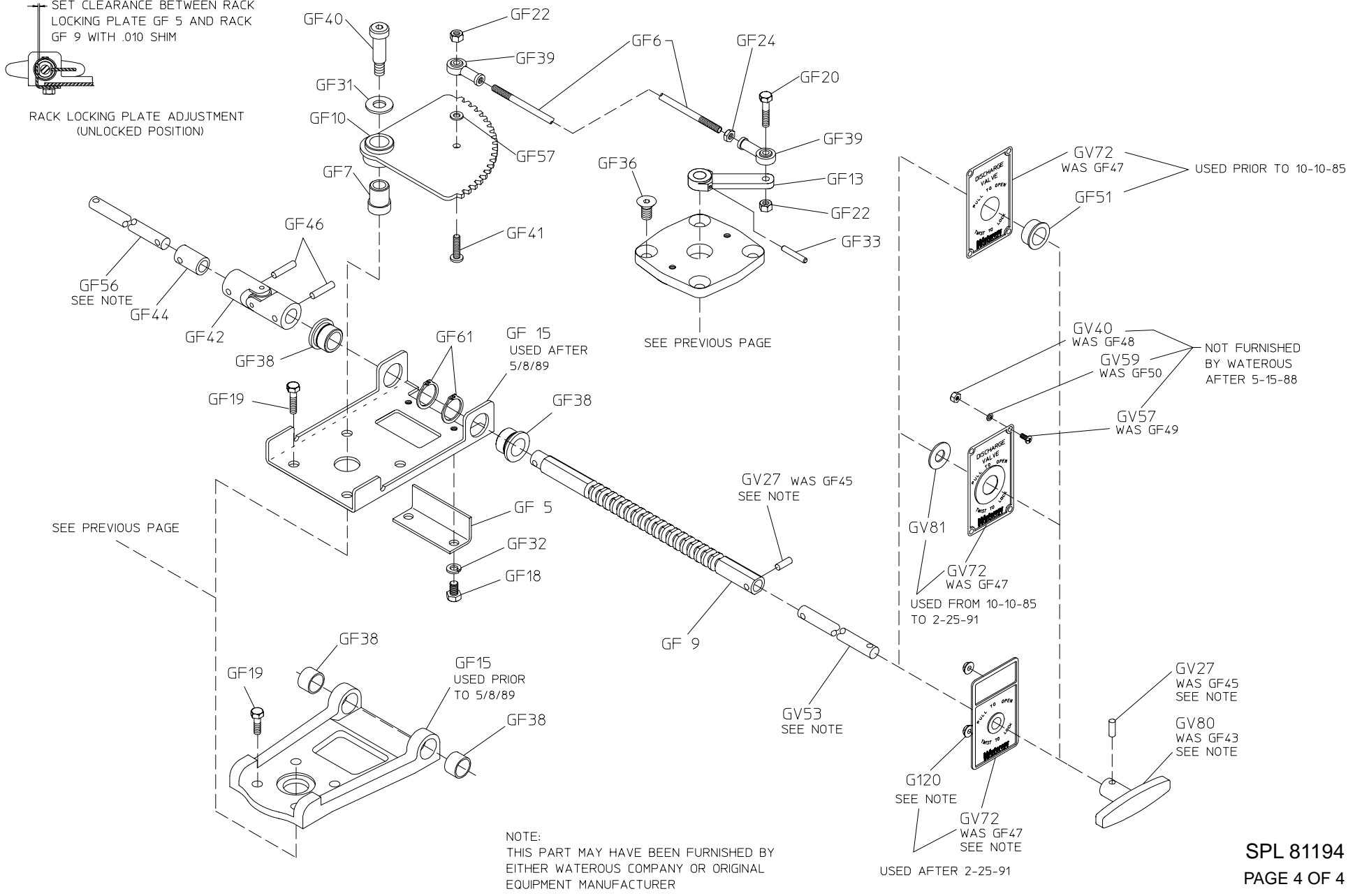

NOTE:
THIS PART MAY HAVE BEEN FURNISHED BY
EITHER WATEROUS COMPANY OR ORIGINAL
EQUIPMENT MANUFACTURER